

**FEATURES**

- TI-OPC™ Circuitry Limits Ringing on Unevenly Loaded Backplanes
- OEC™ Circuitry Improves Signal Integrity and Reduces Electromagnetic Interference
- Bidirectional Interface Between GTLP Signal Levels and LVTTTL Logic Levels
- Split LVTTTL Port Provides a Feedback Path for Control and Diagnostics Monitoring
- LVTTTL Interfaces Are 5-V Tolerant
- High-Drive GTLP Outputs (100 mA)
- LVTTTL Outputs (–24 mA/24 mA)
- Variable Edge-Rate Control (ERC) Input Selects GTLP Rise and Fall Times for Optimal Data-Transfer Rate and Signal Integrity in Distributed Loads
- I<sub>off</sub>, Power-Up 3-State, and BIAS V<sub>CC</sub> Support Live Insertion
- Polarity Control Selects True or Complementary Outputs
- Latch-Up Performance Exceeds 100 mA Per JESD 78, Class II
- ESD Protection Exceeds JESD 22
  - 2000-V Human-Body Model (A114-A)
  - 200-V Machine Model (A115-A)
  - 1000-V Charged-Device Model (C101)

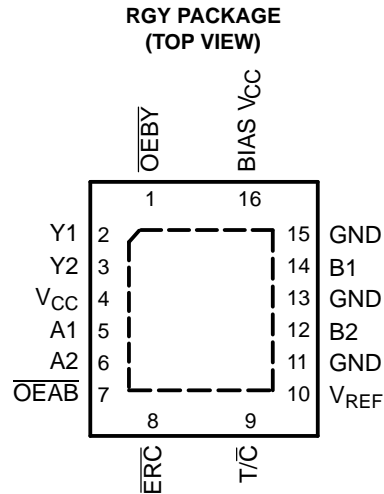
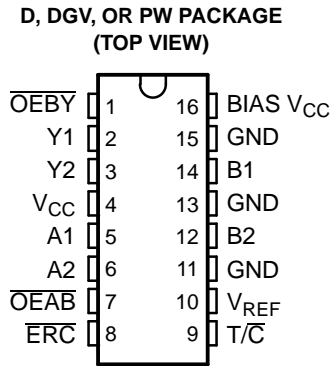

**DESCRIPTION/ORDERING INFORMATION**

**ORDERING INFORMATION**

T <sub>A</sub>	PACKAGE <sup>(1)</sup>		ORDERABLE PART NUMBER	TOP-SIDE MARKING
–40°C to 85°C	QFN – RGY	Tape and reel	SN74GTLP1394RGYR	GP1394
	SOIC – D	Tube	SN74GTLP1394D	GTLP1394
		Tape and reel	SN74GTLP1394DR	
	TSSOP – PW	Tape and reel	SN74GTLP1394PWR	GP394
	TVSOP – DGV	Tape and reel	SN74GTLP1394DGV	GP394

(1) Package drawings, standard packing quantities, thermal data, symbolization, and PCB design guidelines are available at [www.ti.com/sc/package](http://www.ti.com/sc/package).



Please be aware that an important notice concerning availability, standard warranty, and use in critical applications of Texas Instruments semiconductor products and disclaimers thereto appears at the end of this data sheet.

TI-OPC, OEC, TI are trademarks of Texas Instruments.

## DESCRIPTION/ORDERING INFORMATION (CONTINUED)

The SN74GTLP1394 is a high-drive, 2-bit, 3-wire bus transceiver that provides LVTTTL-to-GTLP and GTLP-to-LVTTTL signal-level translation. It allows for transparent and inverted transparent modes of data transfer with separate LVTTTL input and LVTTTL output pins, which provides a feedback path for control and diagnostics monitoring. The device provides a high-speed interface between cards operating at LVTTTL logic levels and a backplane operating at GTLP signal levels, and is especially designed to work with the Texas Instruments (TI™) 1394 backplane physical-layer controllers. High-speed (about three times faster than standard LVTTTL or TTL) backplane operation is a direct result of GTLP reduced output swing ( $<1$  V), reduced input threshold levels, improved differential input, OEC™ circuitry, and TI-OPC™ circuitry. Improved GTLP OEC and TI-OPC circuitry minimizes bus-settling time and have been designed and tested using several backplane models. The high drive allows incident-wave switching in heavily loaded backplanes with equivalent load impedance down to  $11 \Omega$ .

GTLP is the TI derivative of the Gunning Transceiver Logic (GTL) JEDEC standard JESD 8-3. The ac specification of the SN74GTLP1394 is given only at the preferred higher noise margin GTLP, but the user has the flexibility of using this device at either GTL ( $V_{TT} = 1.2$  V and  $V_{REF} = 0.8$  V) or GTLP ( $V_{TT} = 1.5$  V and  $V_{REF} = 1$  V) signal levels.

Normally, the B port operates at GTLP signal levels. The A-port and control inputs operate at LVTTTL logic levels, but are 5-V tolerant and are compatible with TTL and 5-V CMOS inputs.  $V_{REF}$  is the B-port differential input reference voltage.

This device is fully specified for live-insertion applications using  $I_{off}$ , power-up 3-state, and BIAS  $V_{CC}$ . The  $I_{off}$  circuitry disables the outputs, preventing damaging current backflow through the device when it is powered down. The power-up 3-state circuitry places the outputs in the high-impedance state during power up and power down, which prevents driver conflict. The BIAS  $V_{CC}$  circuitry precharges and preconditions the B-port input/output connections, preventing disturbance of active data on the backplane during card insertion or removal and permits true live-insertion capability.

This GTLP device features TI-OPC circuitry, which actively limits the overshoot caused by improperly terminated backplanes, unevenly distributed cards, or empty slots during low-to-high signal transitions. This improves signal integrity, which allows adequate noise margin to be maintained at higher frequencies.

High-drive GTLP backplane interface devices feature adjustable edge-rate control ( $\overline{ERC}$ ). Changing the  $\overline{ERC}$  input voltage between GND and  $V_{CC}$  adjusts the B-port output rise and fall times. This allows the designer to optimize system data-transfer rate and signal integrity to the backplane load.

When  $V_{CC}$  is between 0 and 1.5 V, the device is in the high-impedance state during power up or power down. However, to ensure the high-impedance state above 1.5 V, the output-enable ( $\overline{OE}$ ) input should be tied to  $V_{CC}$  through a pullup resistor; the minimum value of the resistor is determined by the current-sinking capability of the driver.

## FUNCTIONAL DESCRIPTION

The output-enable ( $\overline{OEAB}$ ) input controls the activity of the B port. When  $\overline{OEAB}$  is low, the B-port outputs are active. When  $\overline{OEAB}$  is high, the B-port outputs are disabled.

Separate LVTTTL input and output pins provide a feedback path for control and diagnostics monitoring. The  $\overline{OEBY}$  input controls the Y outputs. When  $\overline{OEBY}$  is low, the Y outputs are active. When  $\overline{OEBY}$  is high, the Y outputs are disabled.

The polarity-control ( $T/\overline{C}$ ) input is provided to select polarity of data transmission in both directions. When  $T/\overline{C}$  is high, data transmission is true, and A data goes to the B bus and B data goes to the Y bus. When  $T/\overline{C}$  is low, data transmission is complementary, and inverted A data goes to the B bus and inverted B data goes to the Y bus.

FUNCTION TABLES

OUTPUT CONTROL

T/C	INPUTS		OUTPUT	MODE
	OEAB	OEBY		
X	H	H	Z	Isolation
H	L	H	A data to B bus	True transparent
H	H	L	B data to Y bus	
H	L	L	A data to B bus, B data to Y bus	True transparent with feedback path
L	L	H	Inverted A data to B bus	Inverted transparent
L	H	L	Inverted B data to Y bus	
L	L	L	Inverted A data to B bus, Inverted B data to Y bus	Inverted transparent with feedback path

OUTPUT EDGE-RATE CONTROL ( $\overline{ERC}$ )

INPUT $\overline{ERC}$		OUTPUT B-PORT EDGE RATE
LOGIC LEVEL	NOMINAL VOLTAGE	
L	GND	Slow
H	V <sub>CC</sub>	Fast

LOGIC DIAGRAM (POSITIVE LOGIC)

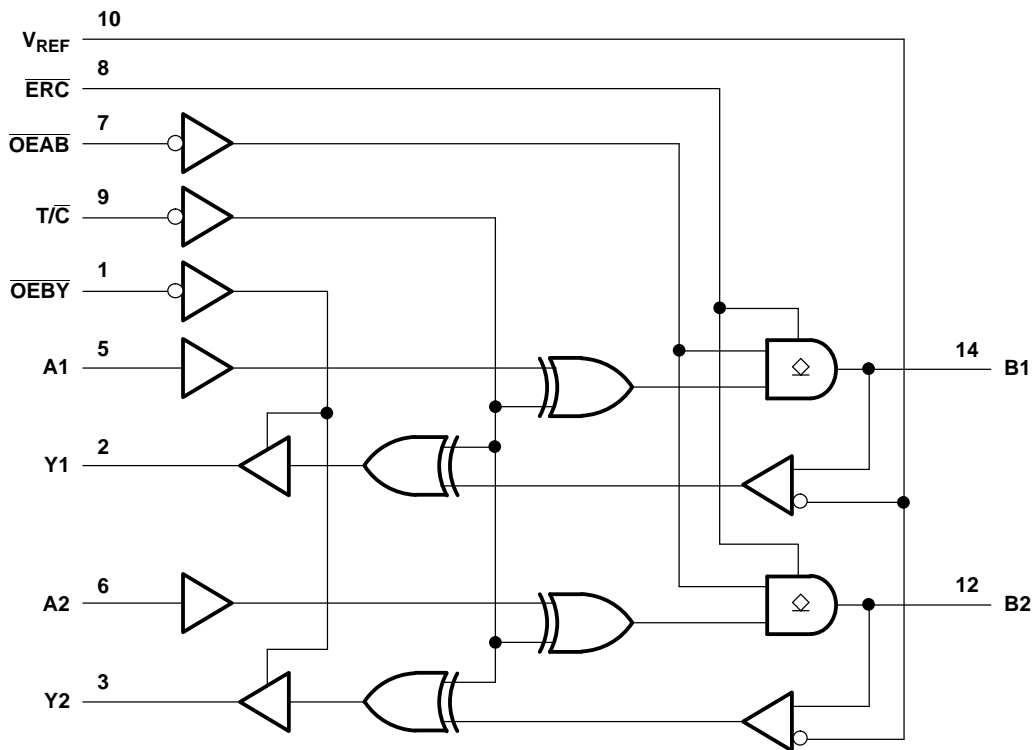

**Absolute Maximum Ratings**<sup>(1)</sup>

over operating free-air temperature range (unless otherwise noted)

		MIN	MAX	UNIT	
$V_{CC}$ BIAS $V_{CC}$	Supply voltage range	–0.5	4.6	V	
$V_I$	Input voltage range <sup>(2)</sup>	A inputs, $\overline{ERC}$ , and control inputs	–0.5	7	V
		B port and $V_{REF}$	–0.5	4.6	
$V_O$	Voltage range applied to any output in the high-impedance or power-off state <sup>(2)</sup>	Y outputs	–0.5	7	V
		B port	–0.5	4.6	
$I_O$	Current into any output in the low state	Y outputs		48	mA
		B port		200	
$I_O$	Current into any output in the high state <sup>(3)</sup>		48	mA	
	Continuous current through each $V_{CC}$ or GND		±100	mA	
$I_{IK}$	Input clamp current	$V_I < 0$	–50	mA	
$I_{OK}$	Output clamp current	$V_O < 0$	–50	mA	
$\theta_{JA}$	Package thermal impedance	D package <sup>(4)</sup>		73	°C/W
		DGV package <sup>(4)</sup>		120	
		PW package <sup>(4)</sup>		108	
		RGY package <sup>(5)</sup>		39	
$T_{stg}$	Storage temperature range	–65	150	°C	

(1) Stresses beyond those listed under "absolute maximum ratings" may cause permanent damage to the device. These are stress ratings only, and functional operation of the device at these or any other conditions beyond those indicated under "recommended operating conditions" is not implied. Exposure to absolute-maximum-rated conditions for extended periods may affect device reliability.

(2) The input and output negative-voltage ratings may be exceeded if the input and output clamp-current ratings are observed.

(3) This current flows only when the output is in the high state and  $V_O > V_{CC}$ .

(4) The package thermal impedance is calculated in accordance with JESD 51-7.

(5) The package thermal impedance is calculated in accordance with JESD 51-5.

**Recommended Operating Conditions**<sup>(1)(2)(3)(4)</sup>

			MIN	NOM	MAX	UNIT
$V_{CC}$ , BIAS $V_{CC}$	Supply voltage		3.15	3.3	3.45	V
$V_{TT}$	Termination voltage	GTL	1.14	1.2	1.26	V
		GTLP	1.35	1.5	1.65	
$V_{REF}$	Reference voltage	GTL	0.74	0.8	0.87	V
		GTLP	0.87	1	1.1	
$V_I$	Input voltage	B port			$V_{TT}$	V
		Except B port		$V_{CC}$	5.5	
$V_{IH}$	High-level input voltage	B port	$V_{REF} + 0.05$			V
		$\overline{ERC}$	$V_{CC} - 0.6$	$V_{CC}$	5.5	
		Except B port and $\overline{ERC}$	2			
$V_{IL}$	Low-level input voltage	B port	$V_{REF} - 0.05$			V
		$\overline{ERC}$		GND	0.6	
		Except B port and $\overline{ERC}$			0.8	
$I_{IK}$	Input clamp current				-18	mA
$I_{OH}$	High-level output current	Y outputs			-24	mA
$I_{OL}$	Low-level output current	Y outputs			24	mA
		B port			100	
$\Delta t/\Delta v$	Input transition rise or fall rate	Outputs enabled			10	ns/V
$\Delta t/\Delta V_{CC}$	Power-up ramp rate		20			$\mu$ s/V
$T_A$	Operating free-air temperature		-40		85	$^{\circ}$ C

- (1) All unused inputs of the device must be held at  $V_{CC}$  or GND to ensure proper device operation. Refer to the TI application report, *Implications of Slow or Floating CMOS Inputs*, literature number SCBA004.
- (2) Proper connection sequence for use of the B-port I/O precharge feature is GND and BIAS  $V_{CC} = 3.3$  V first, I/O second, and  $V_{CC} = 3.3$  V last, because the BIAS  $V_{CC}$  precharge circuitry is disabled when any  $V_{CC}$  pin is connected. The control and  $V_{REF}$  inputs can be connected anytime, but normally are connected during the I/O stage. If B-port precharge is not required, any connection sequence is acceptable, but generally, GND is connected first.
- (3)  $V_{TT}$  and  $R_{TT}$  can be adjusted to accommodate backplane impedances if the dc recommended  $I_{OL}$  ratings are not exceeded.
- (4)  $V_{REF}$  can be adjusted to optimize noise margins, but normally is two-thirds  $V_{TT}$ . TI-OPC circuitry is enabled in the A-to-B direction and is activated when  $V_{TT} > 0.7$  V above  $V_{REF}$ . If operated in the A-to-B direction,  $V_{REF}$  should be set to within 0.6 V of  $V_{TT}$  to minimize current drain.

## Electrical Characteristics

over recommended operating free-air temperature range for GTLP (unless otherwise noted)

PARAMETER		TEST CONDITIONS		MIN	TYP <sup>(1)</sup>	MAX	UNIT
$V_{IK}$		$V_{CC} = 3.15\text{ V}$ ,	$I_I = -18\text{ mA}$			-1.2	V
$V_{OH}$	Y outputs	$V_{CC} = 3.15\text{ V to }3.45\text{ V}$ ,	$I_{OH} = -100\text{ }\mu\text{A}$	$V_{CC} - 0.2$			V
		$V_{CC} = 3.15\text{ V}$	$I_{OH} = -12\text{ mA}$	2.4			
			$I_{OH} = -24\text{ mA}$	2			
$V_{OL}$	Y outputs	$V_{CC} = 3.15\text{ V to }3.45\text{ V}$ ,	$I_{OL} = 100\text{ }\mu\text{A}$			0.2	V
		$V_{CC} = 3.15\text{ V}$	$I_{OL} = 12\text{ mA}$			0.4	
			$I_{OL} = 24\text{ mA}$			0.5	
	B port	$V_{CC} = 3.15\text{ V}$	$I_{OL} = 10\text{ mA}$			0.2	
			$I_{OL} = 64\text{ mA}$			0.4	
			$I_{OL} = 100\text{ mA}$			0.55	
$I_I$	A-port and control inputs	$V_{CC} = 3.45\text{ V}$ ,	$V_I = 0\text{ to }5.5\text{ V}$			$\pm 10$	$\mu\text{A}$
$I_{OZH}^{(2)}$	Y outputs	$V_{CC} = 3.45\text{ V}$	$V_O = V_{CC}$			10	$\mu\text{A}$
	B port		$V_O = 1.5\text{ V}$			10	
$I_{OZL}^{(2)}$	Y outputs and B port	$V_{CC} = 3.45\text{ V}$ ,	$V_O = \text{GND}$			-10	$\mu\text{A}$
$I_{CC}$	Y outputs and B port	$V_{CC} = 3.45\text{ V}$ , $I_O = 0$ , $V_I$ (A-port or control inputs) = $V_{CC}$ or GND, $V_I$ (B port) = $V_{TT}$ or GND	Outputs high			20	mA
			Outputs low			20	
			Outputs disabled			20	
$\Delta I_{CC}^{(3)}$		$V_{CC} = 3.45\text{ V}$ , One A-port or control input at $V_{CC} - 0.6\text{ V}$ , Other A-port or control inputs at $V_{CC}$ or GND				1.5	mA
$C_i$	A-port inputs	$V_I = 3.15\text{ V or }0$			3.5	4.5	$\text{pF}$
	Control inputs				4	5	
$C_o$	Y outputs	$V_O = 3.15\text{ V or }0$			4.5	5	$\text{pF}$
$C_{io}$	B port	$V_O = 1.5\text{ V or }0$			9	10.5	$\text{pF}$

(1) All typical values are at  $V_{CC} = 3.3\text{ V}$ ,  $T_A = 25^\circ\text{C}$ .

(2) For I/O ports, the parameters  $I_{OZH}$  and  $I_{OZL}$  include the input leakage current.

(3) This is the increase in supply current for each input that is at the specified TTL voltage level, rather than  $V_{CC}$  or GND.

## Hot-Insertion Specifications for A Inputs and Y Outputs

over recommended operating free-air temperature range

PARAMETER	TEST CONDITIONS			MIN	MAX	UNIT
$I_{off}$	$V_{CC} = 0$ ,	BIAS $V_{CC} = 0$ ,	$V_I$ or $V_O = 0\text{ to }5.5\text{ V}$		10	$\mu\text{A}$
$I_{OZPU}$	$V_{CC} = 0\text{ to }1.5\text{ V}$ ,	$V_O = 0.5\text{ V to }3\text{ V}$ ,	$\overline{OE} = 0$		$\pm 30$	$\mu\text{A}$
$I_{OZPD}$	$V_{CC} = 1.5\text{ V to }0$ ,	$V_O = 0.5\text{ V to }3\text{ V}$ ,	$\overline{OE} = 0$		$\pm 30$	$\mu\text{A}$

## Live-Insertion Specifications for B Port

over recommended operating free-air temperature range

PARAMETER	TEST CONDITIONS			MIN	MAX	UNIT
$I_{off}$	$V_{CC} = 0$ ,	BIAS $V_{CC} = 0$ ,	$V_I$ or $V_O = 0\text{ to }1.5\text{ V}$		10	$\mu\text{A}$
$I_{OZPU}$	$V_{CC} = 0\text{ to }1.5\text{ V}$ ,	BIAS $V_{CC} = 0$ ,	$V_O = 0.5\text{ V to }1.5\text{ V}$ , $\overline{OE} = 0$		$\pm 30$	$\mu\text{A}$
$I_{OZPD}$	$V_{CC} = 1.5\text{ V to }0$ ,	BIAS $V_{CC} = 0$ ,	$V_O = 0.5\text{ V to }1.5\text{ V}$ , $\overline{OE} = 0$		$\pm 30$	$\mu\text{A}$
$I_{CC}$ (BIAS $V_{CC}$ )	$V_{CC} = 0\text{ to }3.15\text{ V}$	BIAS $V_{CC} = 3.15\text{ V to }3.45\text{ V}$ ,	$V_O$ (B port) = $0\text{ to }1.5\text{ V}$		5	mA
	$V_{CC} = 3.15\text{ V to }3.45\text{ V}$				10	$\mu\text{A}$
$V_O$	$V_{CC} = 0$ ,	BIAS $V_{CC} = 3.3\text{ V}$ ,	$I_O = 0$	0.95	1.05	V
$I_O$	$V_{CC} = 0$ ,	BIAS $V_{CC} = 3.15\text{ V to }3.45\text{ V}$ ,	$V_O$ (B port) = $0.6\text{ V}$	-1		$\mu\text{A}$

### Switching Characteristics

over recommended ranges of supply voltage and operating free-air temperature,  
 $V_{TT} = 1.5\text{ V}$  and  $V_{REF} = 1\text{ V}$  for GTLP (see Figure 1)

PARAMETER	FROM (INPUT)	TO (OUTPUT)	EDGE RATE <sup>(1)</sup>	MIN	TYP <sup>(2)</sup>	MAX	UNIT
$t_{PLH}$	A	B	Slow	3.3		5.9	ns
$t_{PHL}$				3	6.6		
$t_{PLH}$	A	B	Fast	2.5		5.2	ns
$t_{PHL}$				1.9	4.8		
$t_{PLH}$	A	Y	Slow	5.4		9	ns
$t_{PHL}$				4.9	8.6		
$t_{PLH}$	A	Y	Fast	4.3		7.9	ns
$t_{PHL}$				3.9	7.5		
$t_{PLH}$	$T/\bar{C}$	B	Slow	3		6.5	ns
$t_{PHL}$				3.1	6.6		
$t_{PLH}$	$T/\bar{C}$	B	Fast	2.3		5.6	ns
$t_{PHL}$				1.7	4.9		
$t_{en}$	$\overline{OEAB}$	B	Slow	3.2		6.2	ns
$t_{dis}$				3.2	6.4		
$t_{en}$	$\overline{OEAB}$	B	Fast	1.9		5.3	ns
$t_{dis}$				2.4	5.7		
$t_r$	Rise time, B outputs (20% to 80%)		Slow	2.7		ns	
			Fast	1.5			
$t_f$	Fall time, B outputs (80% to 20%)		Slow	3.2		ns	
			Fast	2.1			
$t_{PLH}$	B	Y		1.6	4.6	ns	
$t_{PHL}$			1.4	3.9			
$t_{PLH}$	$T/\bar{C}$	Y		1	4.5	ns	
$t_{PHL}$			1.2	4.1			
$t_{en}$	$\overline{OEBY}$	Y		1	4.1	ns	
$t_{dis}$			1.3	4.6			

(1) Slow ( $\overline{ERC} = \text{GND}$ ) and Fast ( $\overline{ERC} = V_{CC}$ )

(2) All typical values are at  $V_{CC} = 3.3\text{ V}$ ,  $T_A = 25^\circ\text{C}$ .

PARAMETER MEASUREMENT INFORMATION

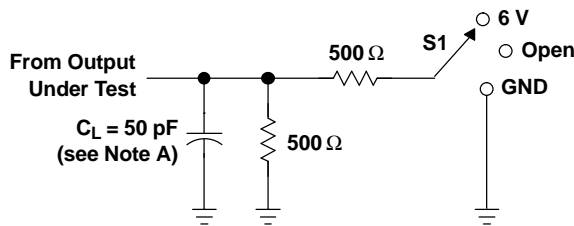

LOAD CIRCUIT FOR Y OUTPUTS

TEST	S1
$t_{PLH}/t_{PHL}$	Open
$t_{PLZ}/t_{PZL}$	6 V
$t_{PHZ}/t_{PZH}$	GND

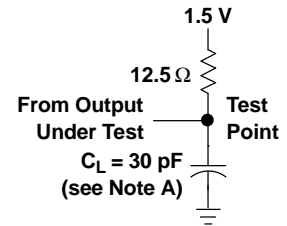

LOAD CIRCUIT FOR B OUTPUTS

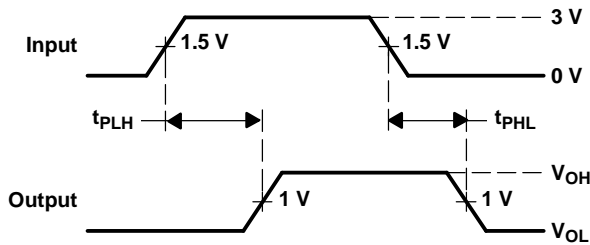

VOLTAGE WAVEFORMS PROPAGATION DELAY TIMES (A input to B port)

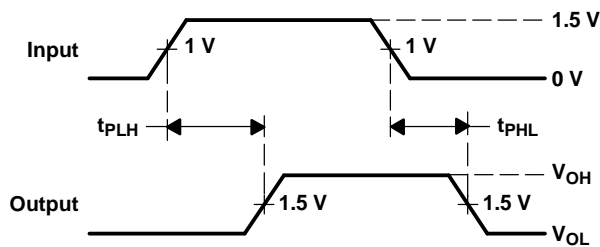

VOLTAGE WAVEFORMS PROPAGATION DELAY TIMES (B port to Y output)

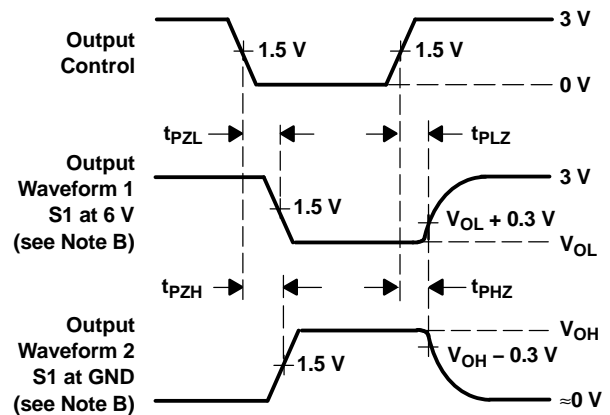

VOLTAGE WAVEFORMS ENABLE AND DISABLE TIMES (A input)

- NOTES: A.  $C_L$  includes probe and jig capacitance.  
 B. Waveform 1 is for an output with internal conditions such that the output is low, except when disabled by the output control. Waveform 2 is for an output with internal conditions such that the output is high, except when disabled by the output control.  
 C. All input pulses are supplied by generators having the following characteristics: PRR  $\approx$  10 MHz,  $Z_O = 50 \Omega$ ,  $t_r \approx 2$  ns,  $t_f \approx 2$  ns.  
 D. The outputs are measured one at a time, with one transition per measurement.

Figure 1. Load Circuits and Voltage Waveforms

### Distributed-Load Backplane Switching Characteristics

The preceding switching characteristics table shows the switching characteristics of the device into a lumped load (Figure 1). However, the designer's backplane application probably is a distributed load. The physical representation is shown in Figure 2. This backplane, or distributed load, can be approximated closely to a resistor inductance capacitance (RLC) circuit, as shown in Figure 3. This device has been designed for optimum performance in this RLC circuit. The following switching characteristics table shows the switching characteristics of the device into the RLC load, to help the designer better understand the performance of the GTLP device in this typical backplane. See [www.ti.com/sc/gtlp](http://www.ti.com/sc/gtlp) for more information.

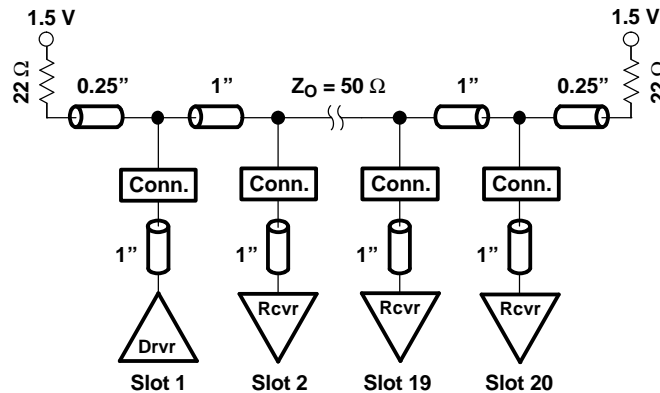

Figure 2. High-Drive Test Backplane

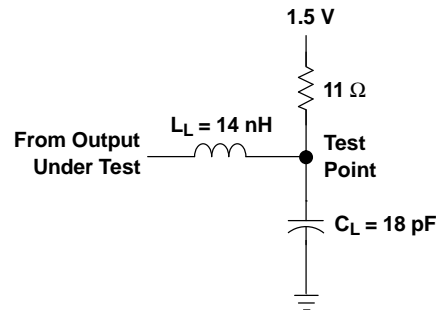

Figure 3. High-Drive RLC Network

### Switching Characteristics

over recommended ranges of supply voltage and operating free-air temperature,  
 $V_{TT} = 1.5\text{ V}$  and  $V_{REF} = 1\text{ V}$  for GTLP (see Figure 3)

PARAMETER	FROM (INPUT)	TO (OUTPUT)	EDGE RATE <sup>(1)</sup>	TYP <sup>(2)</sup>	UNIT
$t_{PLH}$	A	B	Slow	4.2	ns
$t_{PHL}$				4.2	
$t_{PLH}$	A	B	Fast	3.6	ns
$t_{PHL}$				3.6	
$t_{PLH}$	A	Y	Slow	5.8	ns
$t_{PHL}$				5.8	
$t_{PLH}$	A	Y	Fast	5.2	ns
$t_{PHL}$				5.2	
$t_{PLH}$	$T/\bar{C}$	B	Slow	4.4	ns
$t_{PHL}$				4.4	
$t_{PLH}$	$T/\bar{C}$	B	Fast	3.8	ns
$t_{PHL}$				3.8	
$t_{en}$	$\overline{OEAB}$	$\bar{B}$	Slow	4.2	ns
$t_{dis}$				4.3	
$t_{en}$	$\overline{OEAB}$	$\bar{B}$	Fast	3.6	ns
$t_{dis}$				3.3	
$t_r$	Rise time, B outputs (20% to 80%)		Slow	2	ns
			Fast	1.2	
$t_f$	Fall time, B outputs (80% to 20%)		Slow	2.5	ns
			Fast	1.8	

(1) Slow ( $\overline{ERC} = \text{GND}$ ) and Fast ( $\overline{ERC} = V_{CC}$ )

(2) All typical values are at  $V_{CC} = 3.3\text{ V}$ ,  $T_A = 25^\circ\text{C}$ . All values are derived from TI-SPICE models.

## APPLICATION INFORMATION

### Operational Description

The GTLP1394 is designed specifically for use with the TI 1394 backplane layer controller family to transmit the 1394 backplane serial bus across parallel backplanes. But, it is a versatile 2-bit device that also is being used to provide multiple single-bit clocks or an ATM read and write clock in multislot parallel backplane applications.

The 1394-1995 is an IEEE designation for a high-performance serial bus. This serial bus defines both a backplane (e.g., GTLP, VME, FB+, CPCI, etc.) physical layer and a point-to-point cable-connected virtual bus. The backplane version operates at 25, 50, or 100 Mbps, whereas the cable version supports data rates of 100, 200, and 400 Mbps. Both versions are compatible at the link layer and above. The interface standard defines the transmission method, media in the cable version, and protocol. The primary application of the cable version is the interconnection of digital A/V equipment and integration of I/O connectivity at the back panel of personal computers using a low-cost, scalable, high-speed serial interface. The primary application of the backplane version is to provide a robust control interface to each daughter card. The 1394 standard also provides new services, such as real-time I/O and live connect/disconnect capability for external devices.

### Electrical

The 1394 standard is a transaction-based packet technology for cable- or backplane-based environments. Both chassis and peripheral devices can use this technology. The 1394 serial bus is organized as if it were memory space interconnected between devices, or as if devices resided in slots on the main backplane. Device addressing is 64 bits wide, partitioned as ten bits for bus ID, six bits for node ID, and 48 bits for memory addresses. The result is the capability to address up to 1023 buses, with each having up to 63 nodes, each with 281 terabytes of memory. Memory-based addressing, rather than channel addressing, views resources as registers or memory that can be accessed with processor-to-memory transactions. Each bus entity is termed a unit, to be individually addressed, reset, and identified. Multiple nodes can reside physically in a single module, and multiple ports can reside in a single node.

Some key features of the 1394 topology are multimaster capabilities, live connect/disconnect (hot plugging) capability, genderless cabling connectors on interconnect cabling, and dynamic node address allocation as nodes are added to the bus. A maximum of 63 nodes can be connected to one network.

The cable-based physical interface uses dc-level line states for signaling during initialization and arbitration. Both environments use dominant mode addresses for arbitration. The backplane environment does not have the initialization requirements of the cable environment because it is a physical bus and does not contain repeaters. Due to the differences, a backplane-to-cable bridge is required to connect these two environments.

The signals transmitted on both the cable and backplane environments are NRZ with data-strobe (DS) encoding. DS encoding allows only one of the two signal lines to change each data bit-period, essentially doubling the jitter tolerance, with very little additional circuitry overhead in the hardware.

## APPLICATION INFORMATION

### Protocol

Both asynchronous and isochronous data transfers are supported. The asynchronous format transfers data and transaction-layer information to an explicit address. The isochronous format broadcasts data based on channel numbers, rather than specific addressing. Isochronous packets are issued on the average of each 125  $\mu$ s in support of time-sensitive applications. Providing both asynchronous and isochronous formats on the same interface allows both non-real-time and real-time critical applications on the same bus. The cable environment's tree topology is resolved during a sequence of events, triggered each time a new node is added or removed from the network. This sequence starts with a bus reset phase, where previous information about a topology is cleared. The tree ID sequence determines the actual tree structure, and a root node is dynamically assigned, or it is possible to force a particular node to become the root. After the tree is formed, a self-ID phase allows each node on the network to identify itself to all other nodes. During the self-ID process, each node is assigned an address. After all the information has been gathered on each node, the bus goes into an idle state, waiting for the beginning of the standard arbitration process.

The backplane physical layer shares some commonality with the cable physical layer. Common functions include: bus state determination, bus access protocols, encoding and decoding functions, and synchronization of received data to a local clock.

### Backplane Features

- 25-, 50-, and 100-Mbps data rates for backplane environments
- Live connection/disconnection possible without data loss or interruption.
- Configuration ROM and status registers supporting plug and play
- Multidrop or point-to-point topologies supported.
- Specified bandwidth assignments for real-time applications

### Applicability and Typical Application for IEEE Std 1394 Backplane

The 1394 backplane serial bus (BPSB) plays a supportive role in backplane systems, specifically GTLP, FutureBus+, VME64, and proprietary backplane bus systems. This supportive role can be grouped into three categories:

- Diagnostics
  - Alternate control path to the parallel backplane bus
  - Test, maintenance, and troubleshooting
  - Software debug and support interface
- System enhancement
  - Fault tolerance
  - Live insertion
  - CSR access
  - Auxiliary 2-bit bus with a 64-bit address space to the parallel backplane bus
- Peripheral monitoring
  - Monitoring of peripherals (disk drives, fans, power supplies, etc.) in conjunction with another externally wired monitor bus, such as defined by the Intelligent Platform Management Interface (IPMI)

The 1394 backplane physical layer (PHY) and the SN74GTLP1394 provide a cost-effective way to add high-speed 1394 connections to every daughter card in almost any backplane. More information on the backplane physical layer devices and how to implement the 1394 standard in backplane and cable applications can be found at [www.ti.com/sc/1394](http://www.ti.com/sc/1394).

## APPLICATION INFORMATION

### SN74GTLP1394 Interface With the TSB14AA1 1394 Backplane PHY

- A1, B1, and Y1 are used for the PHY data signals.
- A2, B2, and Y2 are used for the PHY strobe signals.
- PHY N\_OEB\_D or  $\overline{\text{OCDOE}}$  connects to  $\overline{\text{OEAB}}$ , which controls the PHY transmit signals.
- $\overline{\text{OEBY}}$  is connected to GND, since the transceiver always must be able to receive signals from the backplane and relay them to the PHY.
- $\text{T}/\overline{\text{C}}$  is connected to GND for inverted signals.
- $V_{\text{CC}}$  is nominal 3.3 V.
- BIAS  $V_{\text{CC}}$  is connected to nominal 3.3 V to support live insertion.
- $V_{\text{REF}}$  normally is  $2/3$  of  $V_{\text{TT}}$ .
- $\overline{\text{ERC}}$  normally is connected to GND for slow edge-rate operation because frequencies of only 50 MHz (S100) and 25 MHz (S50) are required.

### LOGICAL REPRESENTATION

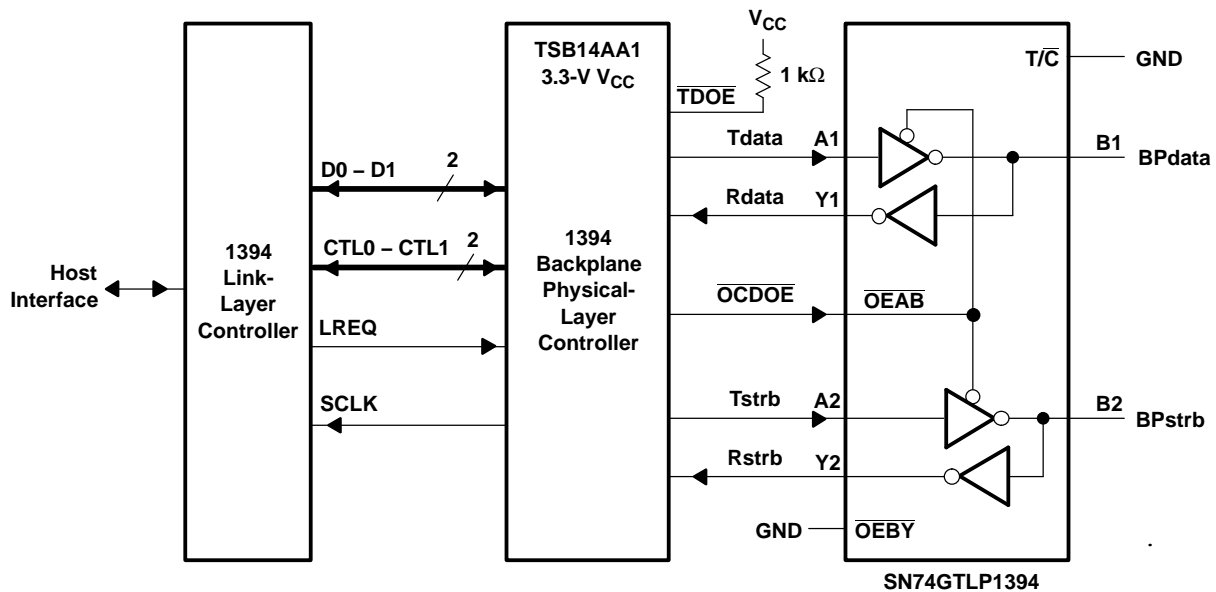

**APPLICATION INFORMATION**

**PHYSICAL REPRESENTATION**

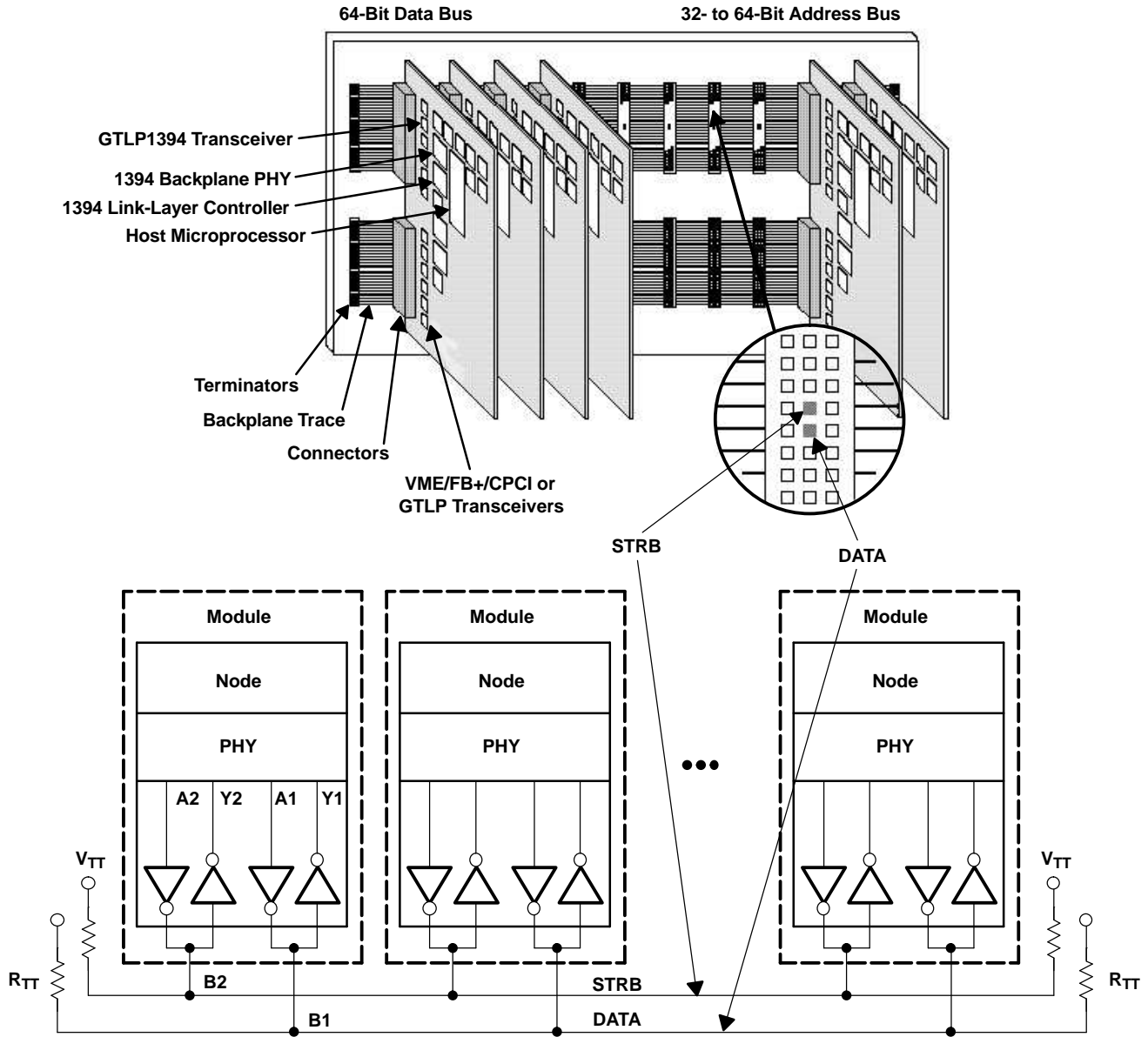

**PACKAGING INFORMATION**

Orderable Device	Status <sup>(1)</sup>	Package Type	Package Drawing	Pins	Package Qty	Eco Plan <sup>(2)</sup>	Lead/Ball Finish	MSL Peak Temp <sup>(3)</sup>
74GTLP1394DGVRE4	ACTIVE	TVSOP	DGV	16	2000	Green (RoHS & no Sb/Br)	CU NIPDAU	Level-1-260C-UNLIM
74GTLP1394DGVRG4	ACTIVE	TVSOP	DGV	16	2000	Green (RoHS & no Sb/Br)	CU NIPDAU	Level-1-260C-UNLIM
74GTLP1394RGYRG4	ACTIVE	QFN	RGY	16		TBD	Call TI	Call TI
SN74GTLP1394D	ACTIVE	SOIC	D	16	40	Green (RoHS & no Sb/Br)	CU NIPDAU	Level-1-260C-UNLIM
SN74GTLP1394DE4	ACTIVE	SOIC	D	16	40	Green (RoHS & no Sb/Br)	CU NIPDAU	Level-1-260C-UNLIM
SN74GTLP1394DG4	ACTIVE	SOIC	D	16	40	Green (RoHS & no Sb/Br)	CU NIPDAU	Level-1-260C-UNLIM
SN74GTLP1394DGV	ACTIVE	TVSOP	DGV	16	2000	Green (RoHS & no Sb/Br)	CU NIPDAU	Level-1-260C-UNLIM
SN74GTLP1394DR	ACTIVE	SOIC	D	16	2500	Green (RoHS & no Sb/Br)	CU NIPDAU	Level-1-260C-UNLIM
SN74GTLP1394DRE4	ACTIVE	SOIC	D	16	2500	Green (RoHS & no Sb/Br)	CU NIPDAU	Level-1-260C-UNLIM
SN74GTLP1394DRG4	ACTIVE	SOIC	D	16	2500	Green (RoHS & no Sb/Br)	CU NIPDAU	Level-1-260C-UNLIM
SN74GTLP1394PW	ACTIVE	TSSOP	PW	16	90	Green (RoHS & no Sb/Br)	CU NIPDAU	Level-1-260C-UNLIM
SN74GTLP1394PWE4	ACTIVE	TSSOP	PW	16	90	Green (RoHS & no Sb/Br)	CU NIPDAU	Level-1-260C-UNLIM
SN74GTLP1394PWG4	ACTIVE	TSSOP	PW	16	90	Green (RoHS & no Sb/Br)	CU NIPDAU	Level-1-260C-UNLIM
SN74GTLP1394PWR	ACTIVE	TSSOP	PW	16	2000	Green (RoHS & no Sb/Br)	CU NIPDAU	Level-1-260C-UNLIM
SN74GTLP1394PWRE4	ACTIVE	TSSOP	PW	16	2000	Green (RoHS & no Sb/Br)	CU NIPDAU	Level-1-260C-UNLIM
SN74GTLP1394PWRG4	ACTIVE	TSSOP	PW	16	2000	Green (RoHS & no Sb/Br)	CU NIPDAU	Level-1-260C-UNLIM

<sup>(1)</sup> The marketing status values are defined as follows:

**ACTIVE:** Product device recommended for new designs.

**LIFEBUY:** TI has announced that the device will be discontinued, and a lifetime-buy period is in effect.

**NRND:** Not recommended for new designs. Device is in production to support existing customers, but TI does not recommend using this part in a new design.

**PREVIEW:** Device has been announced but is not in production. Samples may or may not be available.

**OBSELETE:** TI has discontinued the production of the device.

<sup>(2)</sup> Eco Plan - The planned eco-friendly classification: Pb-Free (RoHS), Pb-Free (RoHS Exempt), or Green (RoHS & no Sb/Br) - please check <http://www.ti.com/productcontent> for the latest availability information and additional product content details.

**TBD:** The Pb-Free/Green conversion plan has not been defined.

**Pb-Free (RoHS):** TI's terms "Lead-Free" or "Pb-Free" mean semiconductor products that are compatible with the current RoHS requirements for all 6 substances, including the requirement that lead not exceed 0.1% by weight in homogeneous materials. Where designed to be soldered at high temperatures, TI Pb-Free products are suitable for use in specified lead-free processes.

**Pb-Free (RoHS Exempt):** This component has a RoHS exemption for either 1) lead-based flip-chip solder bumps used between the die and package, or 2) lead-based die adhesive used between the die and leadframe. The component is otherwise considered Pb-Free (RoHS compatible) as defined above.

**Green (RoHS & no Sb/Br):** TI defines "Green" to mean Pb-Free (RoHS compatible), and free of Bromine (Br) and Antimony (Sb) based flame retardants (Br or Sb do not exceed 0.1% by weight in homogeneous material)

<sup>(3)</sup> MSL, Peak Temp. -- The Moisture Sensitivity Level rating according to the JEDEC industry standard classifications, and peak solder

temperature.

**Important Information and Disclaimer:**The information provided on this page represents TI's knowledge and belief as of the date that it is provided. TI bases its knowledge and belief on information provided by third parties, and makes no representation or warranty as to the accuracy of such information. Efforts are underway to better integrate information from third parties. TI has taken and continues to take reasonable steps to provide representative and accurate information but may not have conducted destructive testing or chemical analysis on incoming materials and chemicals. TI and TI suppliers consider certain information to be proprietary, and thus CAS numbers and other limited information may not be available for release.

In no event shall TI's liability arising out of such information exceed the total purchase price of the TI part(s) at issue in this document sold by TI to Customer on an annual basis.

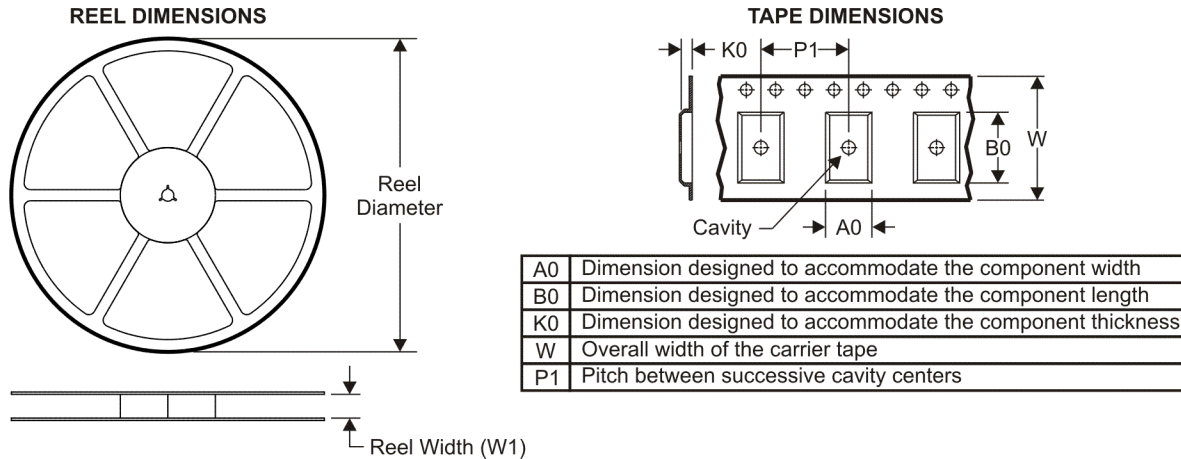
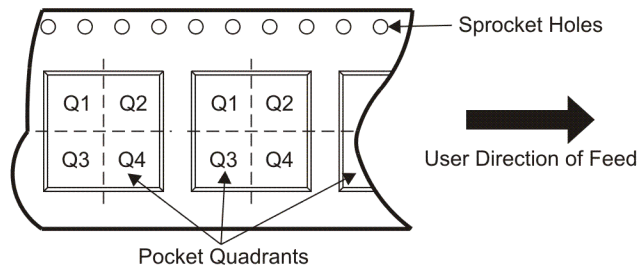
**TAPE AND REEL INFORMATION**

**QUADRANT ASSIGNMENTS FOR PIN 1 ORIENTATION IN TAPE**

\*All dimensions are nominal

Device	Package Type	Package Drawing	Pins	SPQ	Reel Diameter (mm)	Reel Width W1 (mm)	A0 (mm)	B0 (mm)	K0 (mm)	P1 (mm)	W (mm)	Pin1 Quadrant
SN74GTLP1394DGVR	TVSOP	DGV	16	2000	330.0	12.4	6.8	4.0	1.6	8.0	12.0	Q1
SN74GTLP1394DR	SOIC	D	16	2500	330.0	16.4	6.5	10.3	2.1	8.0	16.0	Q1
SN74GTLP1394PWR	TSSOP	PW	16	2000	330.0	12.4	7.0	5.6	1.6	8.0	12.0	Q1

**TAPE AND REEL BOX DIMENSIONS**

\*All dimensions are nominal

Device	Package Type	Package Drawing	Pins	SPQ	Length (mm)	Width (mm)	Height (mm)
SN74GTLP1394DGVR	TVSOP	DGV	16	2000	346.0	346.0	29.0
SN74GTLP1394DR	SOIC	D	16	2500	333.2	345.9	28.6
SN74GTLP1394PWR	TSSOP	PW	16	2000	346.0	346.0	29.0

PW (R-PDSO-G\*\*)

PLASTIC SMALL-OUTLINE PACKAGE

14 PINS SHOWN



4040064/F 01/97

- NOTES: A. All linear dimensions are in millimeters.  
 B. This drawing is subject to change without notice.  
 C. Body dimensions do not include mold flash or protrusion not to exceed 0,15.  
 D. Falls within JEDEC MO-153

DGV (R-PDSO-G\*\*)

PLASTIC SMALL-OUTLINE

24 PINS SHOWN

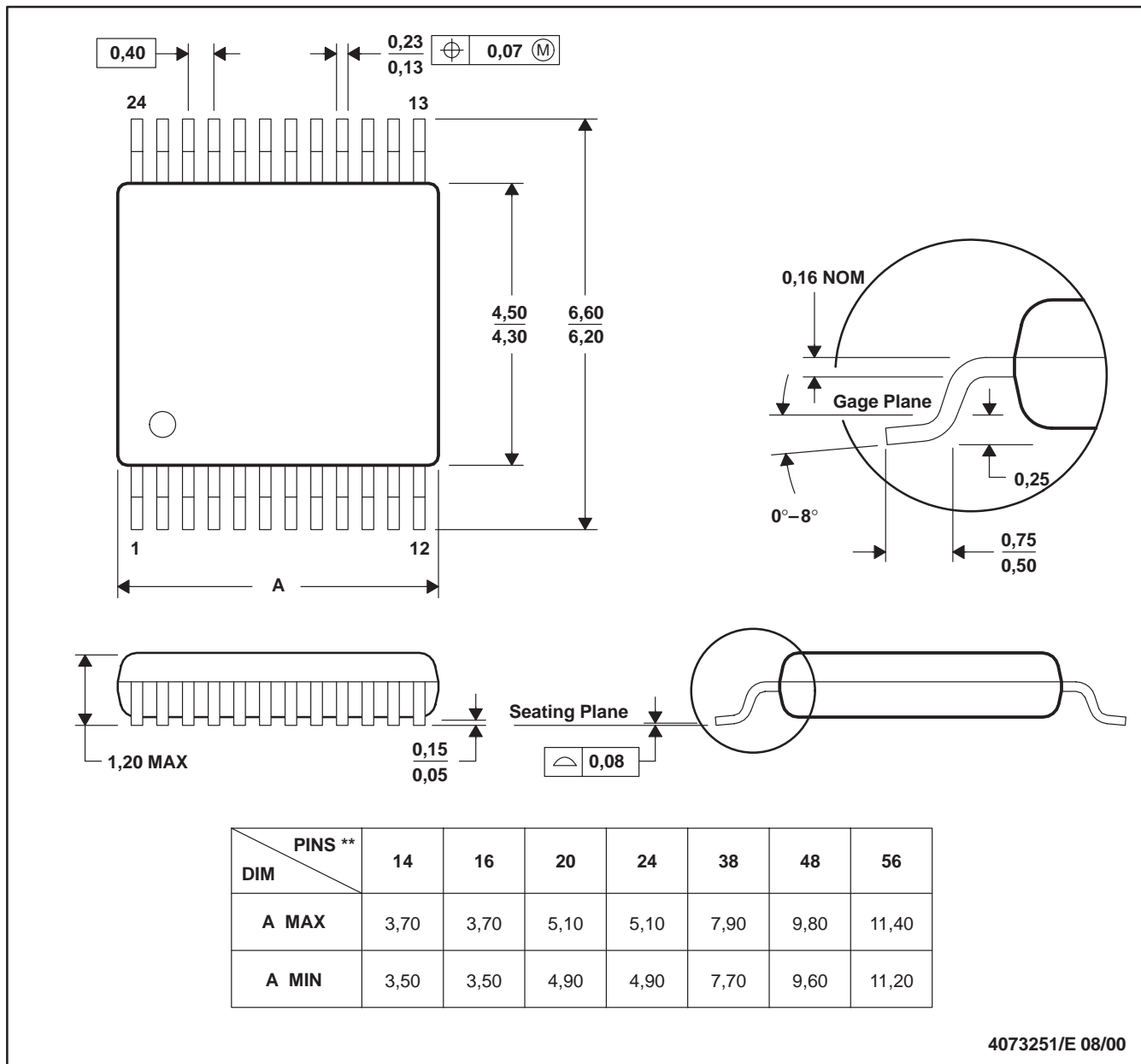

- NOTES: A. All linear dimensions are in millimeters.  
 B. This drawing is subject to change without notice.  
 C. Body dimensions do not include mold flash or protrusion, not to exceed 0,15 per side.  
 D. Falls within JEDEC: 24/48 Pins – MO-153  
 14/16/20/56 Pins – MO-194

D (R-PDSO-G16)

PLASTIC SMALL-OUTLINE PACKAGE

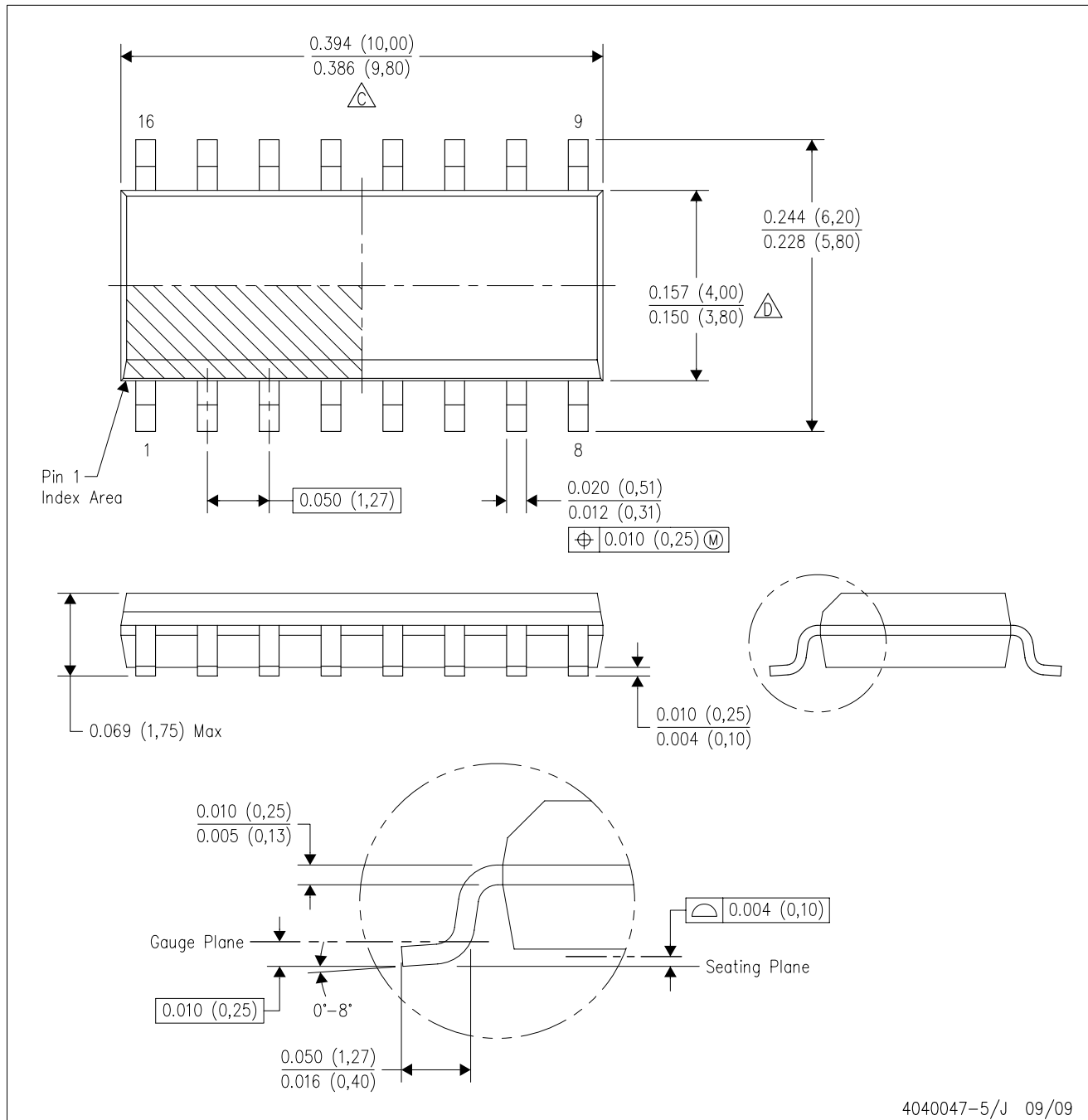

4040047-5/J 09/09

- NOTES:
- A. All linear dimensions are in inches (millimeters).
  - B. This drawing is subject to change without notice.
  - C. Body length does not include mold flash, protrusions, or gate burrs. Mold flash, protrusions, or gate burrs shall not exceed .006 (0,15) per end.
  - D. Body width does not include interlead flash. Interlead flash shall not exceed .017 (0,43) per side.
  - E. Reference JEDEC MS-012 variation AC.

RGY (R-PVQFN-N16)

PLASTIC QUAD FLATPACK NO-LEAD

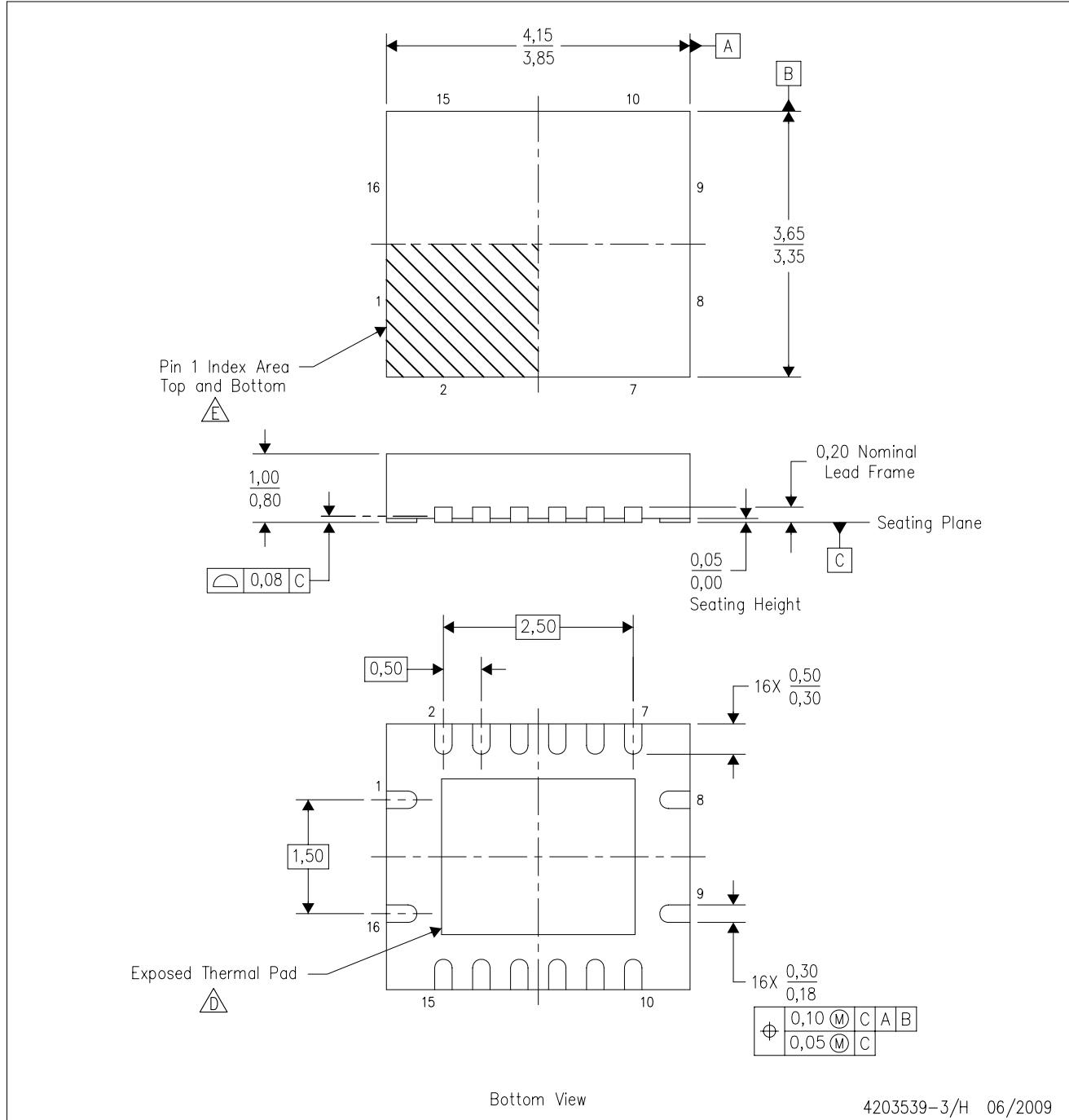

4203539-3/H 06/2009

- NOTES:
- A. All linear dimensions are in millimeters. Dimensioning and tolerancing per ASME Y14.5M-1994.
  - B. This drawing is subject to change without notice.
  - C. QFN (Quad Flatpack No-Lead) package configuration.
  - The package thermal pad must be soldered to the board for thermal and mechanical performance. See the Product Data Sheet for details regarding the exposed thermal pad dimensions.
  - Pin 1 identifiers are located on both top and bottom of the package and within the zone indicated. The Pin 1 identifiers are either a molded, marked, or metal feature.
  - F. Package complies to JEDEC MO-241 variation BB.

## IMPORTANT NOTICE

Texas Instruments Incorporated and its subsidiaries (TI) reserve the right to make corrections, modifications, enhancements, improvements, and other changes to its products and services at any time and to discontinue any product or service without notice. Customers should obtain the latest relevant information before placing orders and should verify that such information is current and complete. All products are sold subject to TI's terms and conditions of sale supplied at the time of order acknowledgment.

TI warrants performance of its hardware products to the specifications applicable at the time of sale in accordance with TI's standard warranty. Testing and other quality control techniques are used to the extent TI deems necessary to support this warranty. Except where mandated by government requirements, testing of all parameters of each product is not necessarily performed.

TI assumes no liability for applications assistance or customer product design. Customers are responsible for their products and applications using TI components. To minimize the risks associated with customer products and applications, customers should provide adequate design and operating safeguards.

TI does not warrant or represent that any license, either express or implied, is granted under any TI patent right, copyright, mask work right, or other TI intellectual property right relating to any combination, machine, or process in which TI products or services are used. Information published by TI regarding third-party products or services does not constitute a license from TI to use such products or services or a warranty or endorsement thereof. Use of such information may require a license from a third party under the patents or other intellectual property of the third party, or a license from TI under the patents or other intellectual property of TI.

Reproduction of TI information in TI data books or data sheets is permissible only if reproduction is without alteration and is accompanied by all associated warranties, conditions, limitations, and notices. Reproduction of this information with alteration is an unfair and deceptive business practice. TI is not responsible or liable for such altered documentation. Information of third parties may be subject to additional restrictions.

Resale of TI products or services with statements different from or beyond the parameters stated by TI for that product or service voids all express and any implied warranties for the associated TI product or service and is an unfair and deceptive business practice. TI is not responsible or liable for any such statements.

TI products are not authorized for use in safety-critical applications (such as life support) where a failure of the TI product would reasonably be expected to cause severe personal injury or death, unless officers of the parties have executed an agreement specifically governing such use. Buyers represent that they have all necessary expertise in the safety and regulatory ramifications of their applications, and acknowledge and agree that they are solely responsible for all legal, regulatory and safety-related requirements concerning their products and any use of TI products in such safety-critical applications, notwithstanding any applications-related information or support that may be provided by TI. Further, Buyers must fully indemnify TI and its representatives against any damages arising out of the use of TI products in such safety-critical applications.

TI products are neither designed nor intended for use in military/aerospace applications or environments unless the TI products are specifically designated by TI as military-grade or "enhanced plastic." Only products designated by TI as military-grade meet military specifications. Buyers acknowledge and agree that any such use of TI products which TI has not designated as military-grade is solely at the Buyer's risk, and that they are solely responsible for compliance with all legal and regulatory requirements in connection with such use.

TI products are neither designed nor intended for use in automotive applications or environments unless the specific TI products are designated by TI as compliant with ISO/TS 16949 requirements. Buyers acknowledge and agree that, if they use any non-designated products in automotive applications, TI will not be responsible for any failure to meet such requirements.

Following are URLs where you can obtain information on other Texas Instruments products and application solutions:

### Products

Amplifiers	<a href="http://amplifier.ti.com">amplifier.ti.com</a>
Data Converters	<a href="http://dataconverter.ti.com">dataconverter.ti.com</a>
DLP® Products	<a href="http://www.dlp.com">www.dlp.com</a>
DSP	<a href="http://dsp.ti.com">dsp.ti.com</a>
Clocks and Timers	<a href="http://www.ti.com/clocks">www.ti.com/clocks</a>
Interface	<a href="http://interface.ti.com">interface.ti.com</a>
Logic	<a href="http://logic.ti.com">logic.ti.com</a>
Power Mgmt	<a href="http://power.ti.com">power.ti.com</a>
Microcontrollers	<a href="http://microcontroller.ti.com">microcontroller.ti.com</a>
RFID	<a href="http://www.ti-rfid.com">www.ti-rfid.com</a>
RF/IF and ZigBee® Solutions	<a href="http://www.ti.com/lprf">www.ti.com/lprf</a>

### Applications

Audio	<a href="http://www.ti.com/audio">www.ti.com/audio</a>
Automotive	<a href="http://www.ti.com/automotive">www.ti.com/automotive</a>
Broadband	<a href="http://www.ti.com/broadband">www.ti.com/broadband</a>
Digital Control	<a href="http://www.ti.com/digitalcontrol">www.ti.com/digitalcontrol</a>
Medical	<a href="http://www.ti.com/medical">www.ti.com/medical</a>
Military	<a href="http://www.ti.com/military">www.ti.com/military</a>
Optical Networking	<a href="http://www.ti.com/opticalnetwork">www.ti.com/opticalnetwork</a>
Security	<a href="http://www.ti.com/security">www.ti.com/security</a>
Telephony	<a href="http://www.ti.com/telephony">www.ti.com/telephony</a>
Video & Imaging	<a href="http://www.ti.com/video">www.ti.com/video</a>
Wireless	<a href="http://www.ti.com/wireless">www.ti.com/wireless</a>

Mailing Address: Texas Instruments, Post Office Box 655303, Dallas, Texas 75265  
Copyright © 2009, Texas Instruments Incorporated