

# SN74FB1650

## 18-BIT TTL/BTL UNIVERSAL STORAGE TRANSCEIVER

SCBS1780 – AUGUST 1992 – REVISED MARCH 2004

- Compatible With IEEE Std 1194.1-1991 (BTL)
- TTL A Port, Backplane Transceiver Logic (BTL)  $\bar{B}$  Port
- Open-Collector  $\bar{B}$ -Port Outputs Sink 100 mA
- BIAS  $V_{CC}$  Minimizes Signal Distortion During Live Insertion or Withdrawal
- High-Impedance State During Power Up and Power Down
- $\bar{B}$ -Port Biasing Network Preconditions the Connector and PC Trace to the BTL High-Level Voltage
- TTL-Input Structures Incorporate Active Clamping to Aid in Line Termination

PCA PACKAGE  
(TOP VIEW)

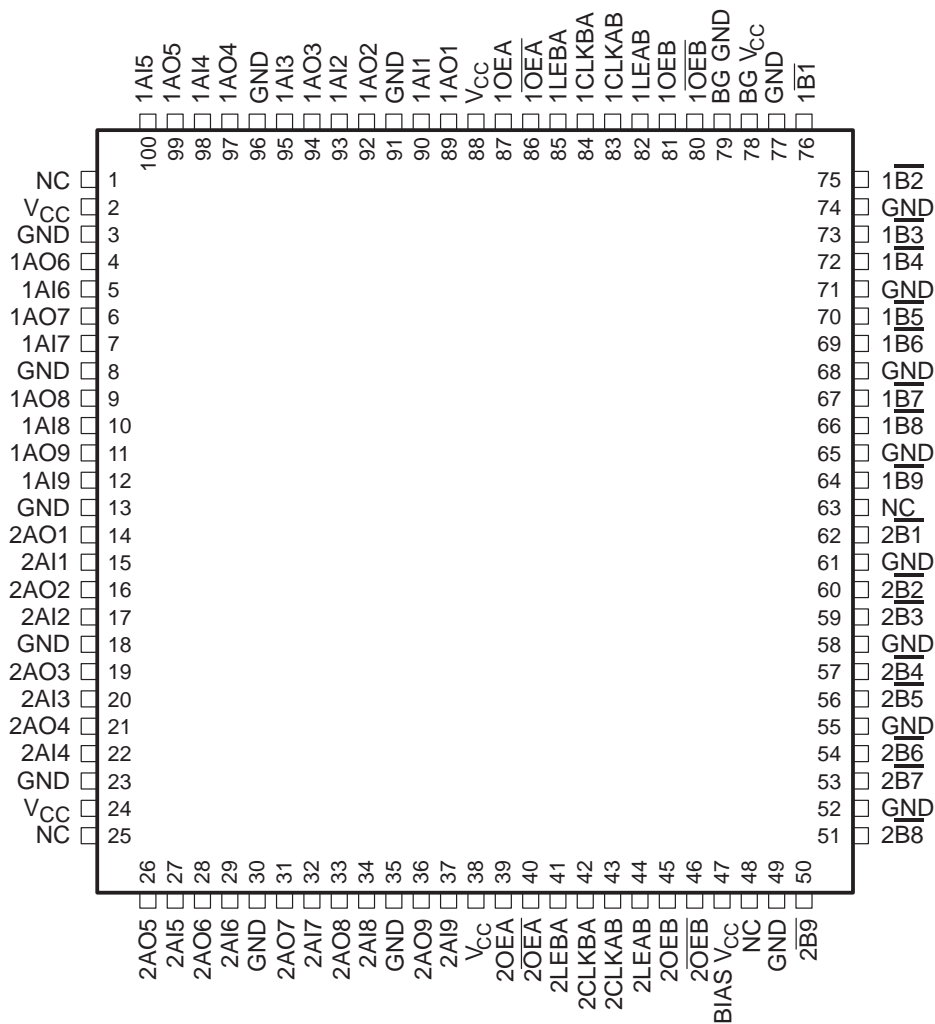

NC – No internal connection



Please be aware that an important notice concerning availability, standard warranty, and use in critical applications of Texas Instruments semiconductor products and disclaimers thereto appears at the end of this data sheet.

PRODUCTION DATA information is current as of publication date. Products conform to specifications per the terms of Texas Instruments standard warranty. Production processing does not necessarily include testing of all parameters.



POST OFFICE BOX 655303 • DALLAS, TEXAS 75265

Copyright © 2004, Texas Instruments Incorporated

# SN74FB1650

## 18-BIT TTL/BTL UNIVERSAL STORAGE TRANSCEIVER

SCBS1780 – AUGUST 1992 – REVISED MARCH 2004

### description/ordering information

The SN74FB1650 contains two 9-bit transceivers designed to translate signals between TTL and backplane transceiver-logic (BTL) environments. The device is designed specifically to be compatible with IEEE Std 1194.1-1991.

The  $\bar{B}$  port operates at BTL-signal levels. The open-collector  $\bar{B}$  ports are specified to sink 100 mA. Two output enables (OEB and  $\overline{OEB}$ ) are provided for the  $\bar{B}$  outputs. When OEB is low,  $\overline{OEB}$  is high, or  $V_{CC}$  is less than 2.1 V, the  $\bar{B}$  port is turned off.

The A port operates at TTL-signal levels. The A outputs reflect the inverse of the data at the  $\bar{B}$  port when the A-port output enable (OEA) is high. When OEA is low or when  $V_{CC}$  is less than 2.1 V, the A outputs are in the high-impedance state.

BIAS  $V_{CC}$  establishes a voltage between 1.62 V and 2.1 V on the BTL outputs when  $V_{CC}$  is not connected.

BG  $V_{CC}$  and BG GND are the supply inputs for the bias generator.

### ORDERING INFORMATION

TA	PACKAGE†		ORDERABLE PART NUMBER	TOP-SIDE MARKING
0°C to 70°C	TQFP – PCA	Tube	SN74FB1650PCA	FB1650

† Package drawings, standard packing quantities, thermal data, symbolization, and PCB design guidelines are available at [www.ti.com/sc/package](http://www.ti.com/sc/package).

### Function Tables

#### TRANSCEIVER

INPUTS				FUNCTION
$\overline{OEA}$	OEA	OEB	$\overline{OEB}$	
X	X	H	L	$\bar{A}$ data to B bus
L	H	X	X	$\bar{B}$ data to A bus
L	H	H	L	$\bar{A}$ data to B bus, $\bar{B}$ data to A bus
X	X	L	X	B-bus isolation
X	X	X	H	
H	X	X	X	A-bus isolation
X	L	X	X	

#### STORAGE MODE

INPUTS		FUNCTION
LE	CLK	
H	X	Transparent
L	↑	Store data
L	L	Storage



**functional block diagram**

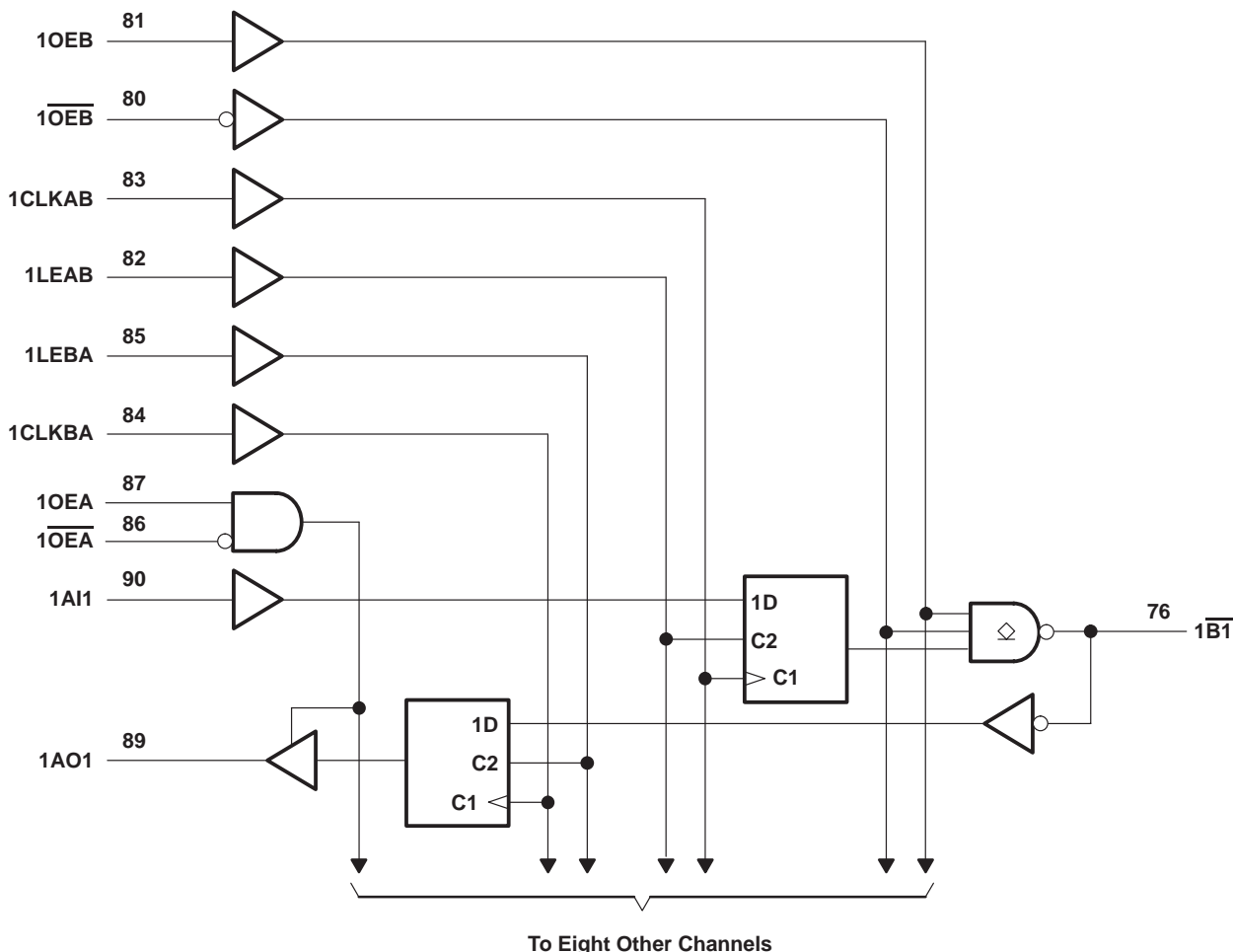

**absolute maximum ratings over operating free-air temperature range (unless otherwise noted)†**

Supply voltage range, $V_{CC}$ , BIAS $V_{CC}$ , BG $V_{CC}$ .....	-0.5 V to 7 V
Input voltage range, $V_I$ : Except $\overline{B}$ port .....	-1.2 V to 7 V
$\overline{B}$ port .....	-1.2 V to 3.5 V
Voltage range applied to any $\overline{B}$ output in the disabled or power-off state, $V_O$ .....	-0.5 V to 3.5 V
Voltage range applied to any output in the high state, $V_O$ .....	-0.5 V to $V_{CC}$
Input clamp current, $I_{IK}$ : Except $\overline{B}$ port .....	-40 mA
$\overline{B}$ port .....	-18 mA
Current applied to any single output in the low state, $I_O$ : A port .....	48 mA
B port .....	200 mA
Package thermal impedance, $\theta_{JA}$ (see Note 1) .....	22°C/W
Storage temperature range, $T_{stg}$ .....	-65°C to 150°C

† Stresses beyond those listed under "absolute maximum ratings" may cause permanent damage to the device. These are stress ratings only, and functional operation of the device at these or any other conditions beyond those indicated under "recommended operating conditions" is not implied. Exposure to absolute-maximum-rated conditions for extended periods may affect device reliability.

NOTE 1: The package thermal impedance is calculated in accordance with JESD 51-7.

# SN74FB1650

## 18-BIT TTL/BTL UNIVERSAL STORAGE TRANSCEIVER

SCBS1780 – AUGUST 1992 – REVISED MARCH 2004

### recommended operating conditions (see Note 2)

		MIN	NOM	MAX	UNIT
$V_{CC}$ , BG $V_{CC}$ , BIAS $V_{CC}$	Supply voltage	4.5	5	5.5	V
$V_{IH}$	High-level input voltage	$\overline{B}$ port	1.62	2.3	V
		Except $\overline{B}$ port	2		
$V_{IL}$	Low-level input voltage	$\overline{B}$ port	0.75	1.47	V
		Except $\overline{B}$ port		0.8	
$I_{IK}$	Input clamp current			-18	mA
$I_{OH}$	High-level output current			-3	mA
$I_{OL}$	Low-level output current	A port		24	mA
		$\overline{B}$ port		100	
$T_A$	Operating free-air temperature	0		70	°C

NOTE 2: To ensure proper device operation, all unused inputs must be terminated as follows: A and control inputs to  $V_{CC}$ (5 V) or GND, and B inputs to GND only. Refer to the TI application report, *Implications of Slow or Floating CMOS Inputs*, literature number SCBA004.

### electrical characteristics over recommended operating free-air temperature range

PARAMETER		TEST CONDITIONS		MIN	TYP†	MAX	UNIT
$V_{IK}$	$\overline{B}$ port	$V_{CC} = 4.5$ V,	$I_I = -18$ mA			-1.2	V
	Except $\overline{B}$ port	$V_{CC} = 4.5$ V,	$I_I = -40$ mA			-0.5	
$V_{OH}$	AO port	$V_{CC} = 4.5$ V,	$I_{OH} = -3$ mA	2.5	3.3		V
$V_{OL}$	AO port	$V_{CC} = 4.5$ V,	$I_{OL} = 24$ mA		0.35	0.5	V
	$\overline{B}$ port	$V_{CC} = 4.5$ V	$I_{OL} = 80$ mA	0.75	1.1		
			$I_{OL} = 100$ mA		1.15		
$I_I$	Except $\overline{B}$ port	$V_{CC} = 5.5$ V,	$V_I = 5.5$ V			50	μA
$I_{IH}‡$	Except $\overline{B}$ port	$V_{CC} = 5.5$ V,	$V_I = 2.7$ V			50	μA
$I_{IL}‡$	Except $\overline{B}$ port	$V_{CC} = 5.5$ V,	$V_I = 0.5$ V			-50	μA
	$\overline{B}$ port	$V_{CC} = 5.5$ V,	$V_I = 0.75$ V			-100	
$I_{OZH}$	AO port	$V_{CC} = 5.5$ V,	$V_O = 2.7$ V			50	μA
$I_{OZL}$	AO port	$V_{CC} = 5.5$ V,	$V_O = 0.5$ V			-50	μA
$I_{OZPU}$	AO port	$V_{CC} = 0$ to 2.1 V,	$V_O = 0.5$ V to 2.7 V			50	μA
$I_{OZPD}$	AO port	$V_{CC} = 2.1$ V to 0,	$V_O = 0.5$ V to 2.7 V			-50	μA
$I_{OH}$	$\overline{B}$ port	$V_{CC} = 0$ to 5.5 V,	$V_O = 2.1$ V			100	μA
$I_{OS}§$	A port	$V_{CC} = 5.5$ V,	$V_O = 0$	-30		-150	mA
$I_{CC}$	A port to $\overline{B}$ port	$V_{CC} = 5.5$ V,	$I_O = 0$			100	mA
	$\overline{B}$ port to A port					120	
$C_i$	AI port	$V_I = V_{CC}$ or GND			5.5		pF
	Control inputs				5.5		
$C_O$	AO ports	$V_O = V_{CC}$ or GND			5.5		pF
$C_{io}$	$\overline{B}$ port per IEEE Std 1194.1-1991	$V_{CC} = 0$ to 5.5 V				5.5	pF

† All typical values are at  $V_{CC} = 5$  V,  $T_A = 25^\circ\text{C}$ .

‡ For I/O ports, the parameters  $I_{IH}$  and  $I_{IL}$  include the off-state output current.

§ Not more than one output should be shorted at a time, and the duration of the short circuit should not exceed one second.



# SN74FB1650

## 18-BIT TTL/BTL UNIVERSAL STORAGE TRANSCEIVER

SCBS1780 – AUGUST 1992 – REVISED MARCH 2004

### live-insertion specifications over recommended operating free-air temperature range

PARAMETER		TEST CONDITIONS		MIN	MAX	UNIT
$I_{CC}$ (BIAS $V_{CC}$ )	$V_{CC} = 0$ to 4.5 V	$V_B = 0$ to 2 V,	$V_I$ (BIAS $V_{CC}$ ) = 4.5 V to 5.5 V	450		$\mu A$
	$V_{CC} = 4.5$ V to 5.5 V			10		
$V_O$	$\overline{B}$ port	$V_{CC} = 0$ ,	$V_I$ (BIAS $V_{CC}$ ) = 5 V	1.62	2.1	V
$I_O$	$\overline{B}$ port	$V_{CC} = 0$ ,	$V_B = 1$ V,	$V_I$ (BIAS $V_{CC}$ ) = 4.5 V to 5.5 V		$\mu A$
		$V_{CC} = 0$ to 2.2 V,	OEB = 0 to 5 V	100		
		$V_{CC} = 0$ to 5.5 V,	OEB = 0 to 0.8 V	1		mA

### timing requirements over recommended ranges of supply voltage and operating free-air temperature (unless otherwise noted) (see Figure 1)

			$V_{CC} = 5$ V, $T_A = 25^\circ C$		MIN	MAX	UNIT
			MIN	MAX			
$f_{clock}$	Clock frequency		150			150	MHz
$t_w$	Pulse duration	CLK or LE	3.3		3.3		ns
$t_{su}$	Setup time	Data before LE	4.8		4.8		ns
		Data before CLK $\uparrow$	4.9		4.9		
$t_h$	Hold time	Data after LE	1.8		1.8		ns
		Data after CLK $\uparrow$	1.1		1.1		



# SN74FB1650

## 18-BIT TTL/BTL UNIVERSAL STORAGE TRANSCEIVER

SCBS1780 – AUGUST 1992 – REVISED MARCH 2004

switching characteristics over recommended ranges of supply voltage and operating free-air temperature (unless otherwise noted) (see Figure 1)

PARAMETER	FROM (INPUT)	TO (OUTPUT)	$V_{CC} = 5\text{ V},$ $T_A = 25^\circ\text{C}$			MIN	MAX	UNIT
			MIN	TYP	MAX			
$f_{max}$			150			150		MHz
$t_{PLH}$	AI	$\bar{B}$	1.8	3.7	5.3	1.8	6.2	ns
$t_{PHL}$			2.9	4.4	6	2.9	7.2	
$t_{PLH}$	LEAB	$\bar{B}$	2.7	4.2	5.8	2.7	6.4	ns
$t_{PHL}$			3.5	5	6.5	3.5	7.3	
$t_{PLH}$	CLKAB	$\bar{B}$	2.3	3.9	5.5	2.3	6	ns
$t_{PHL}$			2.9	4.5	6.1	2.9	6.7	
$t_{PLH}$	$\bar{B}$	AO	3.5	5.9	7.9	3.5	8.6	ns
$t_{PHL}$			2.2	3.7	5.3	2.2	5.7	
$t_{PLH}$	LEBA	AO	1.8	3.2	4.6	1.8	5.1	ns
$t_{PHL}$			1.7	3	4.4	1.7	4.7	
$t_{PLH}$	CLKBA	AO	1.8	3.1	4.6	1.8	5.1	ns
$t_{PHL}$			1.7	3.1	4.6	1.7	4.9	
$t_{PLH}$	OEB	$\bar{B}$	2.7	4.6	6.4	2.7	6.7	ns
$t_{PHL}$			2.9	4.1	5.9	2.9	6.6	
$t_{PLH}$	$\overline{OEB}$	$\bar{B}$	2.6	4.3	6.2	2.6	6.6	ns
$t_{PHL}$			3.4	4.6	6.4	3.4	7	
$t_{PZH}$	OEA	AO	1.4	2.9	4.4	1.4	4.9	ns
$t_{PZL}$			1.4	2.6	4	1.4	4.6	
$t_{PHZ}$	OEA	AO	1.7	3.4	5.1	1.7	5.8	ns
$t_{PLZ}$			2.2	3.6	5	2.2	5.5	
$t_{PZH}$	$\overline{OEA}$	AO	1.7	3.3	4.7	1.7	5.5	ns
$t_{PZL}$			1.7	3.1	4.4	1.7	5.1	
$t_{PHZ}$	$\overline{OEA}$	AO	1.5	2.9	4.5	1.5	5.1	ns
$t_{PLZ}$			2	3.1	4.6	2	4.8	
$t_{sk(p)}^\dagger$	Pulse skew, AI to $\bar{B}$ or $\bar{B}$ to AO		1					ns
$t_{sk(o)}^\dagger$	Output skew, AI to $\bar{B}$ or $\bar{B}$ to AO		0.5					ns
$t_t$ Transition time	$\bar{B}$ outputs (1.3 V to 1.8 V)		0.9	1.7	3.1	0.5	4.6	ns
	AO outputs (10% to 90%)		0.5	2	3.6	0.4	4.2	
$t_{(pr)}$	$\bar{B}$ -port input pulse rejection		1			1		ns

<sup>†</sup> Skew values are applicable for through mode only.



**PARAMETER MEASUREMENT INFORMATION**

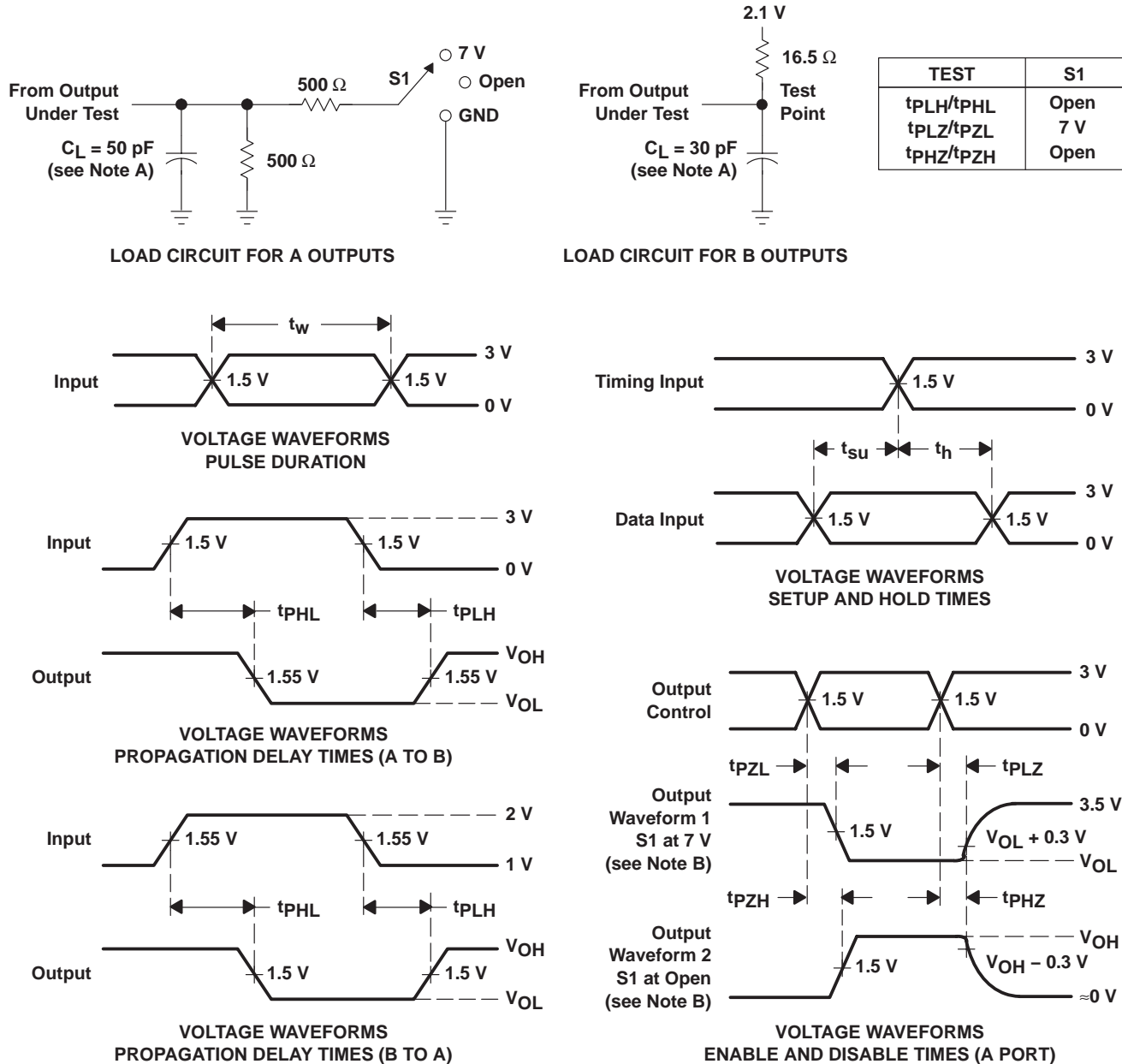

- NOTES: A.  $C_L$  includes probe and jig capacitance.  
 B. Waveform 1 is for an output with internal conditions such that the output is low, except when disabled by the output control. Waveform 2 is for an output with internal conditions such that the output is high, except when disabled by the output control.  
 C. All input pulses are supplied by generators having the following characteristics: TTL inputs:  $PRR \leq 10$  MHz,  $Z_O = 50 \Omega$ ,  $t_r \leq 2.5$  ns,  $t_f \leq 2.5$  ns; BTL inputs:  $PRR \leq 10$  MHz,  $Z_O = 50 \Omega$ ,  $t_r \leq 2.5$  ns,  $t_f \leq 2.5$  ns.  
 D. The outputs are measured one at a time, with one transition per measurement.

**Figure 1. Load Circuits and Voltage Waveforms**

**PACKAGING INFORMATION**

Orderable Device	Status <sup>(1)</sup>	Package Type	Package Drawing	Pins	Package Qty	Eco Plan <sup>(2)</sup>	Lead/Ball Finish	MSL Peak Temp <sup>(3)</sup>
SN74FB1650PCA	ACTIVE	HLQFP	PCA	100	90	Green (RoHS & no Sb/Br)	CU NIPDAU	Level-3-260C-168 HR
SN74FB1650PCAG4	ACTIVE	HLQFP	PCA	100	90	Green (RoHS & no Sb/Br)	CU NIPDAU	Level-3-260C-168 HR

<sup>(1)</sup> The marketing status values are defined as follows:

**ACTIVE:** Product device recommended for new designs.

**LIFEBUY:** TI has announced that the device will be discontinued, and a lifetime-buy period is in effect.

**NRND:** Not recommended for new designs. Device is in production to support existing customers, but TI does not recommend using this part in a new design.

**PREVIEW:** Device has been announced but is not in production. Samples may or may not be available.

**OBsolete:** TI has discontinued the production of the device.

<sup>(2)</sup> Eco Plan - The planned eco-friendly classification: Pb-Free (RoHS), Pb-Free (RoHS Exempt), or Green (RoHS & no Sb/Br) - please check <http://www.ti.com/productcontent> for the latest availability information and additional product content details.

**TBD:** The Pb-Free/Green conversion plan has not been defined.

**Pb-Free (RoHS):** TI's terms "Lead-Free" or "Pb-Free" mean semiconductor products that are compatible with the current RoHS requirements for all 6 substances, including the requirement that lead not exceed 0.1% by weight in homogeneous materials. Where designed to be soldered at high temperatures, TI Pb-Free products are suitable for use in specified lead-free processes.

**Pb-Free (RoHS Exempt):** This component has a RoHS exemption for either 1) lead-based flip-chip solder bumps used between the die and package, or 2) lead-based die adhesive used between the die and leadframe. The component is otherwise considered Pb-Free (RoHS compatible) as defined above.

**Green (RoHS & no Sb/Br):** TI defines "Green" to mean Pb-Free (RoHS compatible), and free of Bromine (Br) and Antimony (Sb) based flame retardants (Br or Sb do not exceed 0.1% by weight in homogeneous material)

<sup>(3)</sup> MSL, Peak Temp. -- The Moisture Sensitivity Level rating according to the JEDEC industry standard classifications, and peak solder temperature.

**Important Information and Disclaimer:**The information provided on this page represents TI's knowledge and belief as of the date that it is provided. TI bases its knowledge and belief on information provided by third parties, and makes no representation or warranty as to the accuracy of such information. Efforts are underway to better integrate information from third parties. TI has taken and continues to take reasonable steps to provide representative and accurate information but may not have conducted destructive testing or chemical analysis on incoming materials and chemicals. TI and TI suppliers consider certain information to be proprietary, and thus CAS numbers and other limited information may not be available for release.

In no event shall TI's liability arising out of such information exceed the total purchase price of the TI part(s) at issue in this document sold by TI to Customer on an annual basis.

PCA (S-PQFP-G100)

PLASTIC QUAD FLATPACK (DIE DOWN)

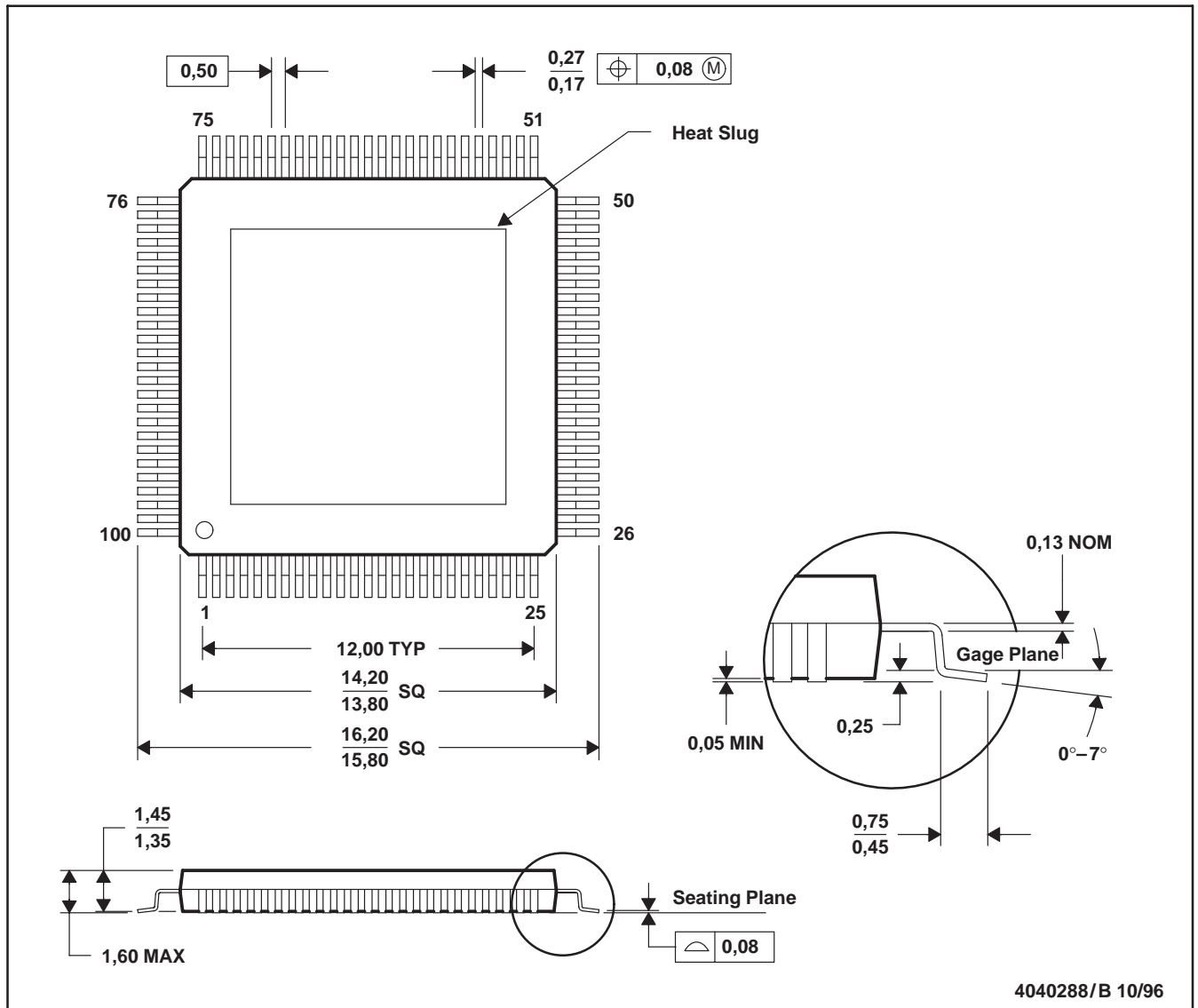

- NOTES: A. All linear dimensions are in millimeters.  
 B. This drawing is subject to change without notice.  
 C. Thermally enhanced molded plastic package with a heat slug (HSL)  
 D. Falls within JEDEC MS-026

## IMPORTANT NOTICE

Texas Instruments Incorporated and its subsidiaries (TI) reserve the right to make corrections, modifications, enhancements, improvements, and other changes to its products and services at any time and to discontinue any product or service without notice. Customers should obtain the latest relevant information before placing orders and should verify that such information is current and complete. All products are sold subject to TI's terms and conditions of sale supplied at the time of order acknowledgment.

TI warrants performance of its hardware products to the specifications applicable at the time of sale in accordance with TI's standard warranty. Testing and other quality control techniques are used to the extent TI deems necessary to support this warranty. Except where mandated by government requirements, testing of all parameters of each product is not necessarily performed.

TI assumes no liability for applications assistance or customer product design. Customers are responsible for their products and applications using TI components. To minimize the risks associated with customer products and applications, customers should provide adequate design and operating safeguards.

TI does not warrant or represent that any license, either express or implied, is granted under any TI patent right, copyright, mask work right, or other TI intellectual property right relating to any combination, machine, or process in which TI products or services are used. Information published by TI regarding third-party products or services does not constitute a license from TI to use such products or services or a warranty or endorsement thereof. Use of such information may require a license from a third party under the patents or other intellectual property of the third party, or a license from TI under the patents or other intellectual property of TI.

Reproduction of information in TI data books or data sheets is permissible only if reproduction is without alteration and is accompanied by all associated warranties, conditions, limitations, and notices. Reproduction of this information with alteration is an unfair and deceptive business practice. TI is not responsible or liable for such altered documentation.

Resale of TI products or services with statements different from or beyond the parameters stated by TI for that product or service voids all express and any implied warranties for the associated TI product or service and is an unfair and deceptive business practice. TI is not responsible or liable for any such statements.

Following are URLs where you can obtain information on other Texas Instruments products and application solutions:

<b>Products</b>		<b>Applications</b>	
Amplifiers	<a href="http://amplifier.ti.com">amplifier.ti.com</a>	Audio	<a href="http://www.ti.com/audio">www.ti.com/audio</a>
Data Converters	<a href="http://dataconverter.ti.com">dataconverter.ti.com</a>	Automotive	<a href="http://www.ti.com/automotive">www.ti.com/automotive</a>
DSP	<a href="http://dsp.ti.com">dsp.ti.com</a>	Broadband	<a href="http://www.ti.com/broadband">www.ti.com/broadband</a>
Interface	<a href="http://interface.ti.com">interface.ti.com</a>	Digital Control	<a href="http://www.ti.com/digitalcontrol">www.ti.com/digitalcontrol</a>
Logic	<a href="http://logic.ti.com">logic.ti.com</a>	Military	<a href="http://www.ti.com/military">www.ti.com/military</a>
Power Mgmt	<a href="http://power.ti.com">power.ti.com</a>	Optical Networking	<a href="http://www.ti.com/opticalnetwork">www.ti.com/opticalnetwork</a>
Microcontrollers	<a href="http://microcontroller.ti.com">microcontroller.ti.com</a>	Security	<a href="http://www.ti.com/security">www.ti.com/security</a>
Low Power Wireless	<a href="http://www.ti.com/lpw">www.ti.com/lpw</a>	Telephony	<a href="http://www.ti.com/telephony">www.ti.com/telephony</a>
		Video & Imaging	<a href="http://www.ti.com/video">www.ti.com/video</a>
		Wireless	<a href="http://www.ti.com/wireless">www.ti.com/wireless</a>

Mailing Address: Texas Instruments  
Post Office Box 655303 Dallas, Texas 75265