

# SN54F573, SN74F573 OCTAL TRANSPARENT D-TYPE LATCHES WITH 3-STATE OUTPUTS

SDFS011A – MARCH 1987 – REVISED OCTOBER 1993

- Eight Latches in a Single Package
- 3-State Bus-Driving True Outputs
- Full Parallel Access for Loading
- Buffered Control Inputs
- Package Options Include Plastic Small-Outline Packages, Ceramic Chip Carriers, and Standard Plastic and Ceramic 300-mil DIPs

## description

These 8-bit latches feature 3-state outputs designed specifically for driving highly capacitive or relatively low-impedance loads. They are particularly suitable for implementing buffer registers, I/O ports, bidirectional bus drivers, and working registers.

The eight latches of the 'F573 are transparent D-type latches. While the latch enable (LE) input is high, the Q outputs follow the data (D) inputs. When the latch enable is taken low, the Q outputs are latched at the logic levels set up at the D inputs.

A buffered output enable ( $\overline{OE}$ ) input can be used to place the eight outputs in either a normal logic state (high or low logic levels) or a high-impedance state. In the high-impedance state, the outputs neither load nor drive the bus lines significantly. The high-impedance state and increased drive provide the capability to drive bus lines without need for interface or pullup components.

The output enable ( $\overline{OE}$ ) input does not affect the internal operations of the latches. Old data can be retained or new data can be entered while the outputs are in the high-impedance state.

The SN54F573 is characterized for operation over the full military temperature range of  $-55^{\circ}\text{C}$  to  $125^{\circ}\text{C}$ . The SN74F573 is characterized for operation from  $0^{\circ}\text{C}$  to  $70^{\circ}\text{C}$ .

SN54F573 . . . J PACKAGE  
SN74F573 . . . DW OR N PACKAGE  
(TOP VIEW)

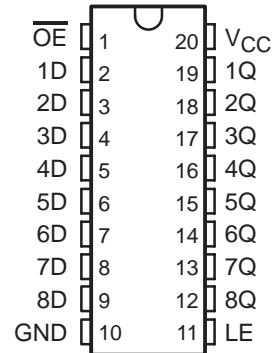

SN54F573 . . . FK PACKAGE  
(TOP VIEW)

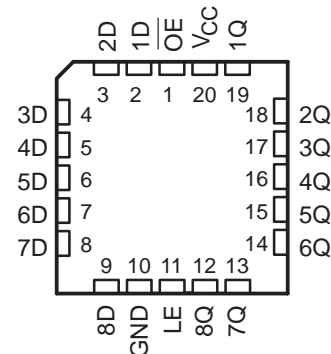

FUNCTION TABLE  
(each latch)

INPUTS			OUTPUT
$\overline{OE}$	LE	D	Q
L	H	H	H
L	H	L	L
L	L	X	$Q_0$
H	X	X	Z

# SN54F573, SN74F573 OCTAL TRANSPARENT D-TYPE LATCHES WITH 3-STATE OUTPUTS

SDFS011A – MARCH 1987 – REVISED OCTOBER 1993

## logic symbol†

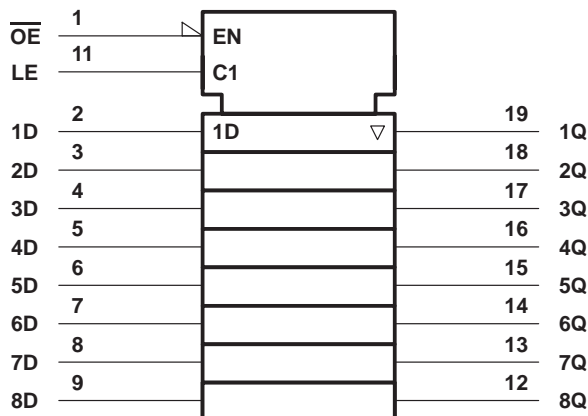

## logic diagram (positive logic)

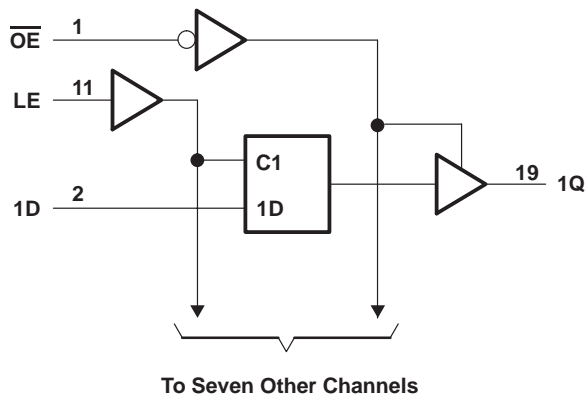

† This symbol is in accordance with ANSI/IEEE Std 91-1984 and IEC Publication 617-12.

## absolute maximum ratings over operating free-air temperature range (unless otherwise noted)‡

Supply voltage range, $V_{CC}$ .....	-0.5 V to 7 V
Input voltage range, $V_I$ (see Note 1) .....	-1.2 V to 7 V
Input current range .....	-30 mA to 5 mA
Voltage range applied to any output in the disabled or power-off state .....	-0.5 V to 5.5 V
Voltage range applied to any output in the high state .....	-0.5 V to $V_{CC}$
Current into any output in the low state: SN54F573 .....	40 mA
SN74F573 .....	48 mA
Operating free-air temperature range: SN54F573 .....	-55°C to 125°C
SN74F573 .....	0°C to 70°C
Storage temperature range .....	-65°C to 150°C

‡ Stresses beyond those listed under "absolute maximum ratings" may cause permanent damage to the device. These are stress ratings only and functional operation of the device at these or any other conditions beyond those indicated under "recommended operating conditions" is not implied. Exposure to absolute-maximum-rated conditions for extended periods may affect device reliability.

NOTE 1: The input voltage ratings may be exceeded provided the input current ratings are observed.

## recommended operating conditions

		SN54F573			SN74F573			UNIT
		MIN	NOM	MAX	MIN	NOM	MAX	
$V_{CC}$	Supply voltage	4.5	5	5.5	4.5	5	5.5	V
$V_{IH}$	High-level input voltage	2			2			V
$V_{IL}$	Low-level input voltage			0.8			0.8	V
$I_{IK}$	Input clamp current			-18			-18	mA
$I_{OH}$	High-level output current			-3			-3	mA
$I_{OL}$	Low-level output current			20			24	mA
$T_A$	Operating free-air temperature	-55		125	0		70	°C



# SN54F573, SN74F573 OCTAL TRANSPARENT D-TYPE LATCHES WITH 3-STATE OUTPUTS

SDFS011A – MARCH 1987 – REVISED OCTOBER 1993

electrical characteristics over recommended operating free-air temperature range (unless otherwise noted)

PARAMETER	TEST CONDITIONS		SN54F573			SN74F573			UNIT
			MIN	TYP†	MAX	MIN	TYP†	MAX	
$V_{IK}$	$V_{CC} = 4.5 V$ ,	$I_I = -18 mA$			-1.2			-1.2	V
$V_{OH}$	$V_{CC} = 4.5 V$	$I_{OH} = -1 mA$	2.5	3.4		2.5	3.4		V
		$I_{OH} = -3 mA$	2.4	3.3		2.4	3.3		
$V_{OL}$	$V_{CC} = 4.75 V$ ,	$I_{OH} = -1 mA$ to $-3 mA$				2.7			V
		$V_{CC} = 4.5 V$	$I_{OL} = 20 mA$	0.3	0.5				
		$I_{OL} = 24 mA$				0.35	0.5		
$I_{OZH}$	$V_{CC} = 5.5 V$ ,	$V_O = 2.7 V$			50			50	$\mu A$
$I_{OZL}$	$V_{CC} = 5.5 V$ ,	$V_O = 0.5 V$			-50			-50	$\mu A$
$I_I$	$V_{CC} = 5.5 V$ ,	$V_I = 7 V$			0.1			0.1	mA
$I_{IH}$	$V_{CC} = 5.5 V$ ,	$V_I = 2.7 V$			20			20	$\mu A$
$I_{IL}$	$V_{CC} = 5.5 V$ ,	$V_I = 0.5 V$			-0.6			-0.6	mA
$I_{OS}^\ddagger$	$V_{CC} = 5.5 V$ ,	$V_O = 0$	-60		-150	-60		-150	mA
$I_{CCZ}$	$V_{CC} = 5.5 V$ ,	See Note 2		38	55		38	55	mA

† All typical values are at  $V_{CC} = 5 V$ ,  $T_A = 25^\circ C$ .

‡ Not more than one output should be shorted at a time, and the duration of the short circuit should not exceed one second.

NOTE 2:  $I_{CCZ}$  is measured with  $\overline{OE}$  at 4.5 V and all other inputs grounded.

timing requirements over recommended ranges of supply voltage and operating free-air temperature (unless otherwise noted)

		$V_{CC} = 5 V$ , $T_A = 25^\circ C$		SN54F573		SN74F573		UNIT
		'F573						
		MIN	MAX	MIN	MAX	MIN	MAX	
$t_w$	Pulse duration, LE high	6		6		6		ns
$t_{su}$	Setup time, data before LE↓	2		2		2		ns
$t_h$	Hold time, data after LE↓	3		3		3		ns

switching characteristics (see Note 3)

PARAMETER	FROM (INPUT)	TO (OUTPUT)	$V_{CC} = 5 V$ , $C_L = 50 pF$ , $R_L = 500 \Omega$ , $T_A = 25^\circ C$			$V_{CC} = 4.5 V$ to $5.5 V$ , $C_L = 50 pF$ , $R_L = 500 \Omega$ , $T_A = \text{MIN to MAX}^\S$				UNIT
			'F573			SN54F573		SN74F573		
			MIN	TYP	MAX	MIN	MAX	MIN	MAX	
$t_{PLH}$	D	Q	2	4.9	7	1.5	9	2.2	8	ns
$t_{PHL}$			1.2	3.3	5	1	8	1.2	6	
$t_{PLH}$	LE	Q	4.2	8.6	11.5	3.7	13.5	4.2	13	ns
$t_{PHL}$			2.2	4.8	7	1.5	9	2.2	8	
$t_{PZH}$	$\overline{OE}$	Q	1.2	4.6	11	1	13	1.2	12	ns
$t_{PZL}$			1.2	5.2	7.5	1	10	1.2	8.5	
$t_{PHZ}$	$\overline{OE}$	Q	1.2	4.1	6.5	1	8.5	1.2	7.5	ns
$t_{PLZ}$			1.2	3.4	6	1	7	1.2	6	

§ For conditions shown as MIN or MAX, use the appropriate value specified under recommended operating conditions.

NOTE 3: Load circuits and waveforms are shown in Section 1.





## IMPORTANT NOTICE

Texas Instruments Incorporated and its subsidiaries (TI) reserve the right to make corrections, modifications, enhancements, improvements, and other changes to its products and services at any time and to discontinue any product or service without notice. Customers should obtain the latest relevant information before placing orders and should verify that such information is current and complete. All products are sold subject to TI's terms and conditions of sale supplied at the time of order acknowledgment.

TI warrants performance of its hardware products to the specifications applicable at the time of sale in accordance with TI's standard warranty. Testing and other quality control techniques are used to the extent TI deems necessary to support this warranty. Except where mandated by government requirements, testing of all parameters of each product is not necessarily performed.

TI assumes no liability for applications assistance or customer product design. Customers are responsible for their products and applications using TI components. To minimize the risks associated with customer products and applications, customers should provide adequate design and operating safeguards.

TI does not warrant or represent that any license, either express or implied, is granted under any TI patent right, copyright, mask work right, or other TI intellectual property right relating to any combination, machine, or process in which TI products or services are used. Information published by TI regarding third-party products or services does not constitute a license from TI to use such products or services or a warranty or endorsement thereof. Use of such information may require a license from a third party under the patents or other intellectual property of the third party, or a license from TI under the patents or other intellectual property of TI.

Reproduction of TI information in TI data books or data sheets is permissible only if reproduction is without alteration and is accompanied by all associated warranties, conditions, limitations, and notices. Reproduction of this information with alteration is an unfair and deceptive business practice. TI is not responsible or liable for such altered documentation. Information of third parties may be subject to additional restrictions.

Resale of TI products or services with statements different from or beyond the parameters stated by TI for that product or service voids all express and any implied warranties for the associated TI product or service and is an unfair and deceptive business practice. TI is not responsible or liable for any such statements.

TI products are not authorized for use in safety-critical applications (such as life support) where a failure of the TI product would reasonably be expected to cause severe personal injury or death, unless officers of the parties have executed an agreement specifically governing such use. Buyers represent that they have all necessary expertise in the safety and regulatory ramifications of their applications, and acknowledge and agree that they are solely responsible for all legal, regulatory and safety-related requirements concerning their products and any use of TI products in such safety-critical applications, notwithstanding any applications-related information or support that may be provided by TI. Further, Buyers must fully indemnify TI and its representatives against any damages arising out of the use of TI products in such safety-critical applications.

TI products are neither designed nor intended for use in military/aerospace applications or environments unless the TI products are specifically designated by TI as military-grade or "enhanced plastic." Only products designated by TI as military-grade meet military specifications. Buyers acknowledge and agree that any such use of TI products which TI has not designated as military-grade is solely at the Buyer's risk, and that they are solely responsible for compliance with all legal and regulatory requirements in connection with such use.

TI products are neither designed nor intended for use in automotive applications or environments unless the specific TI products are designated by TI as compliant with ISO/TS 16949 requirements. Buyers acknowledge and agree that, if they use any non-designated products in automotive applications, TI will not be responsible for any failure to meet such requirements.

Following are URLs where you can obtain information on other Texas Instruments products and application solutions:

### Products

Amplifiers	<a href="http://amplifier.ti.com">amplifier.ti.com</a>
Data Converters	<a href="http://dataconverter.ti.com">dataconverter.ti.com</a>
DSP	<a href="http://dsp.ti.com">dsp.ti.com</a>
Clocks and Timers	<a href="http://www.ti.com/clocks">www.ti.com/clocks</a>
Interface	<a href="http://interface.ti.com">interface.ti.com</a>
Logic	<a href="http://logic.ti.com">logic.ti.com</a>
Power Mgmt	<a href="http://power.ti.com">power.ti.com</a>
Microcontrollers	<a href="http://microcontroller.ti.com">microcontroller.ti.com</a>
RFID	<a href="http://www.ti-rfid.com">www.ti-rfid.com</a>
RF/IF and ZigBee® Solutions	<a href="http://www.ti.com/lprf">www.ti.com/lprf</a>

### Applications

Audio	<a href="http://www.ti.com/audio">www.ti.com/audio</a>
Automotive	<a href="http://www.ti.com/automotive">www.ti.com/automotive</a>
Broadband	<a href="http://www.ti.com/broadband">www.ti.com/broadband</a>
Digital Control	<a href="http://www.ti.com/digitalcontrol">www.ti.com/digitalcontrol</a>
Medical	<a href="http://www.ti.com/medical">www.ti.com/medical</a>
Military	<a href="http://www.ti.com/military">www.ti.com/military</a>
Optical Networking	<a href="http://www.ti.com/opticalnetwork">www.ti.com/opticalnetwork</a>
Security	<a href="http://www.ti.com/security">www.ti.com/security</a>
Telephony	<a href="http://www.ti.com/telephony">www.ti.com/telephony</a>
Video & Imaging	<a href="http://www.ti.com/video">www.ti.com/video</a>
Wireless	<a href="http://www.ti.com/wireless">www.ti.com/wireless</a>

Mailing Address: Texas Instruments, Post Office Box 655303, Dallas, Texas 75265  
Copyright © 2008, Texas Instruments Incorporated