

# SN74F543 OCTAL REGISTERED TRANSCEIVER WITH 3-STATE OUTPUTS

SDFS025B – D2942, MARCH 1987 – REVISED OCTOBER 1993

- 3-State True Outputs
- Back-to-Back Registers for Storage
- Package Options Include Plastic Small-Outline and Shrink Small-Outline Packages and Standard Plastic 300-mil DIPs

## description

The SN74F543 octal transceiver contains two sets of D-type latches for temporary storage of data flowing in either direction. Separate latch-enable ( $\overline{LEAB}$  or  $\overline{LEBA}$ ) and output enable ( $\overline{OEAB}$  or  $\overline{OEBA}$ ) inputs are provided for each register to permit independent control in either direction of data flow. The A outputs are characterized to sink 24 mA while the B outputs are characterized to sink 64 mA.

The A-to-B enable ( $\overline{CEAB}$ ) input must be low in order to enter data from A or to output data from B. Having  $\overline{CEAB}$  low and  $\overline{LEAB}$  low makes the A-to-B latches transparent; a subsequent low-to-high transition of  $\overline{LEAB}$  puts the A latches in the storage mode. With  $\overline{CEAB}$  and  $\overline{OEAB}$  both low, the 3-state B outputs are active and reflect the data present at the output of the A latches. Data flow from B to A is similar, but requires using the  $\overline{CEBA}$ ,  $\overline{LEBA}$ , and  $\overline{OEBA}$  inputs.

The SN74F543 is available in TI's shrink small-outline package (DB), which provides the same I/O pin count and functionality of standard small-outline packages in less than half the printed-circuit-board area.

The SN74F543 is characterized for operation from 0°C to 70°C.

DB, DW, OR NT PACKAGE  
(TOP VIEW)

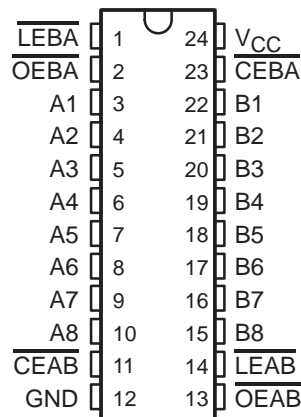

FUNCTION TABLE†

INPUTS				OUTPUT
$\overline{CEAB}$	$\overline{LEAB}$	$\overline{OEAB}$	A	B
H	X	X	X	Z
X	X	H	X	Z
L	H	L	X	$B_0^\ddagger$
L	L	L	L	L
L	L	L	H	H

† A-to-B data flow is shown; B-to-A flow control is the same except that it uses  $\overline{CEBA}$ ,  $\overline{LEBA}$ , and  $\overline{OEBA}$ .

‡ Output level before the indicated steady-state input conditions were established.

# SN74F543 OCTAL REGISTERED TRANSCIEVER WITH 3-STATE OUTPUTS

SDFS025B – D2942, MARCH 1987 – REVISED OCTOBER 1993

## logic symbol†

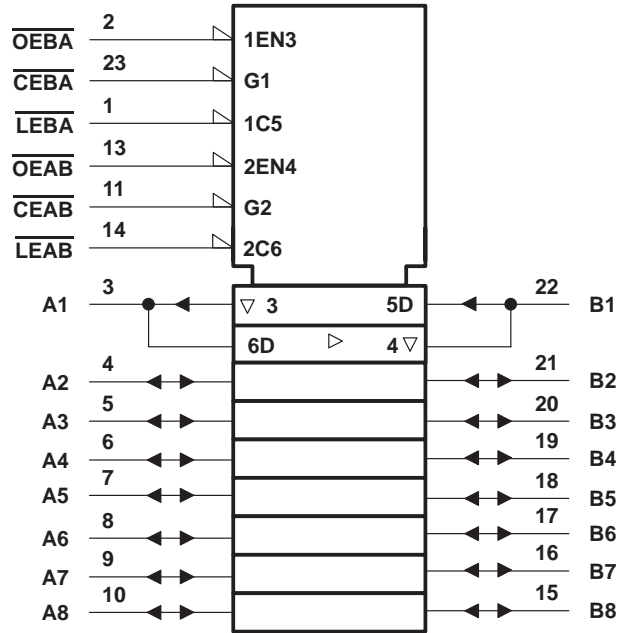

† This symbol is in accordance with ANSI/IEEE Std 91-1984 and IEC Publication 617-12.

## logic diagram (positive logic)

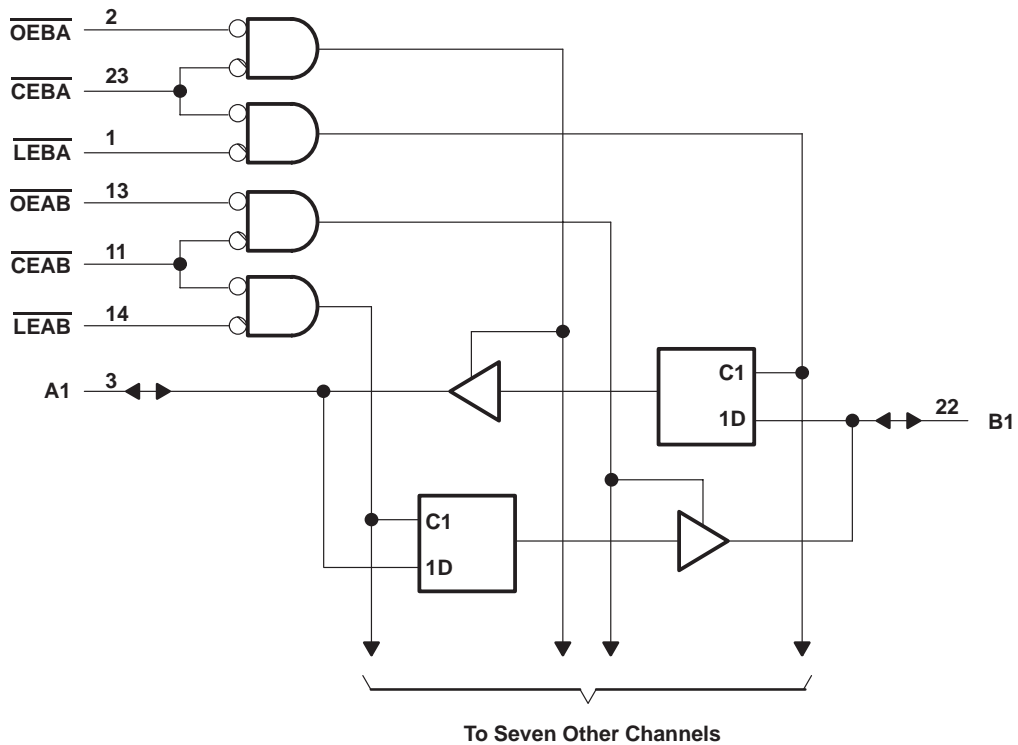

**SN74F543**  
**OCTAL REGISTERED TRANSCEIVER**  
**WITH 3-STATE OUTPUTS**

SDFS025B – D2942, MARCH 1987 – REVISED OCTOBER 1993

**absolute maximum ratings over operating free-air temperature range (unless otherwise noted)†**

Supply voltage range, $V_{CC}$ .....	–0.5 V to 7 V
Input voltage range, $V_I$ (excluding I/O ports) (see Note 1) .....	–1.2 V to 7 V
Input current range, $I_{IK}$ .....	–30 mA to 5 mA
Voltage range applied to any output in the disabled or power-off state .....	–0.5 V to 5.5 V
Voltage range applied to any output in the high state .....	–0.5 V to $V_{CC}$
Current into any output in the low state: A1–A8 .....	48 mA
B1–B8 .....	128 mA
Operating free-air temperature range .....	0°C to 70°C
Storage temperature range .....	–65°C to 150°C

† Stresses beyond those listed under “absolute maximum ratings” may cause permanent damage to the device. These are stress ratings only, and functional operation of the device at these or any other conditions beyond those indicated under “recommended operating conditions” is not implied. Exposure to absolute-maximum-rated conditions for extended periods may affect device reliability.

NOTE 1: The input-voltage ratings may be exceeded provided the input-current ratings are observed.

**recommended operating conditions**

		MIN	NOM	MAX	UNIT
$V_{CC}$	Supply voltage	4.5	5	5.5	V
$V_{IH}$	High-level input voltage	2			V
$V_{IL}$	Low-level input voltage			0.8	V
$I_{IK}$	Input clamp current			–18	mA
$I_{OH}$	High-level output current	A1–A8		–3	mA
		B1–B8		–15	
$I_{OL}$	Low-level output current	A1–A8		24	mA
		B1–B8		64	
$T_A$	Operating free-air temperature	0		70	°C



# SN74F543

## OCTAL REGISTERED TRANSCEIVER WITH 3-STATE OUTPUTS

SDFS025B – D2942, MARCH 1987 – REVISED OCTOBER 1993

electrical characteristics over recommended operating free-air temperature range (unless otherwise noted)

PARAMETER		TEST CONDITIONS		MIN	TYP†	MAX	UNIT
$V_{IK}$		$V_{CC} = 4.5\text{ V}$ ,	$I_I = -18\text{ mA}$			-1.2	V
$V_{OH}$	A1–A8	$V_{CC} = 4.5\text{ V}$	$I_{OH} = -1\text{ mA}$	2.5	3.4		V
			$I_{OH} = -3\text{ mA}$	2.4	3.3		
	B1–B8		$I_{OH} = -3\text{ mA}$	2.4	3.3		
			$I_{OH} = -15\text{ mA}$	2	3.1		
Any output		$V_{CC} = 4.75\text{ V}$ ,	$I_{OH} = -1\text{ mA to } -3\text{ mA}$	2.7			
$V_{OL}$	A1–A8	$V_{CC} = 4.5\text{ V}$	$I_{OL} = 24\text{ mA}$		0.3	0.5	V
	B1–B8		$I_{OL} = 64\text{ mA}$		0.42	0.55	
$I_I$	$\overline{OE}$ , $\overline{LE}$ , and $\overline{CE}$	$V_{CC} = 5.5\text{ V}$	$V_I = 7\text{ V}$			0.1	mA
	A and B ports		$V_I = 5.5\text{ V}$			1	
$I_{IH}‡$	$\overline{OE}$ , $\overline{LE}$ , and $\overline{CE}$	$V_{CC} = 5.5\text{ V}$ ,	$V_I = 2.7\text{ V}$			20	$\mu\text{A}$
	A and B ports					70	
$I_{IL}‡$	$\overline{OE}$ , $\overline{LE}$ , and $\overline{CE}$	$V_{CC} = 5.5\text{ V}$ ,	$V_I = 0.5\text{ V}$			-1.2	mA
	A and B ports					-0.65	
$I_{OS}§$	A1–A8	$V_{CC} = 5.5\text{ V}$ ,	$V_O = 0$			-60	mA
	B1–B8					-100	
$I_{CCH}$		$V_{CC} = 5.5\text{ V}$			67	100	mA
$I_{CCL}$		$V_{CC} = 5.5\text{ V}$			83	125	mA
$I_{CCZ}$		$V_{CC} = 5.5\text{ V}$			83	125	mA

† All typical values are at  $V_{CC} = 5\text{ V}$ ,  $T_A = 25^\circ\text{C}$ .

‡ For I/O ports, the parameters  $I_{IH}$  and  $I_{IL}$  include the off-state output current.

§ Not more than one output should be shorted at a time, and the duration of the short circuit should not exceed one second.

### timing requirements

		$V_{CC} = 5\text{ V}$ , $T_A = 25^\circ\text{C}$		$V_{CC} = 4.5\text{ V to } 5.5\text{ V}$ , $T_A = \text{MIN to MAX}¶$		UNIT
		MIN	MAX	MIN	MAX	
$t_w$	Pulse duration	5		5		ns
$t_{su}$	Setup time, data before latch enable		High or low	3	3.5	ns
$t_h$	Hold time, data after latch enable		High or low	3	3.5	ns

¶ For conditions shown as MIN or MAX, use the appropriate value specified under recommended operating conditions.

**SN74F543**  
**OCTAL REGISTERED TRANSCEIVER**  
**WITH 3-STATE OUTPUTS**

SDFS025B – D2942, MARCH 1987 – REVISED OCTOBER 1993

**switching characteristics (see Note 2)**

PARAMETER	FROM (INPUT)	TO (OUTPUT)	V <sub>CC</sub> = 5 V, C <sub>L</sub> = 50 pF, R <sub>L</sub> = 500 Ω, T <sub>A</sub> = 25°C			V <sub>CC</sub> = 4.5 V to 5.5 V, C <sub>L</sub> = 50 pF, R <sub>L</sub> = 500 Ω, T <sub>A</sub> = MIN to MAX†		UNIT
			MIN	TYP	MAX	MIN	MAX	
t <sub>PLH</sub>	A or B	B or A	2.2	5.1	7.5	2.2	8.5	ns
t <sub>PHL</sub>			2.2	4.6	6.5	2.2	7.5	
t <sub>PLH</sub>	$\overline{LEBA}$	A	3.7	8.1	11	4.1	12.5	ns
t <sub>PHL</sub>			3.7	8.1	11	4.1	12.5	
t <sub>PLH</sub>	$\overline{LEAB}$	B	3.7	8.1	11	4.1	12.5	ns
t <sub>PHL</sub>			3.7	8.1	11	4.1	12.5	
t <sub>PZH</sub>	$\overline{OE}$ or $\overline{CE}$	A or B	2.2	6.6	9	2.2	10	ns
t <sub>PZL</sub>			3.2	7.1	10.5	3.2	12	
t <sub>PHZ</sub>	$\overline{OE}$ or $\overline{CE}$	A or B	1.7	5.6	8	1.7	9	ns
t <sub>PLZ</sub>			1.7	5.1	7.5	1.7	8.5	

† For conditions shown as MIN or MAX, use the appropriate value specified under recommended operating conditions.

NOTE 2: Load circuits and waveforms are shown in Section 1.



**PACKAGING INFORMATION**

Orderable Device	Status <sup>(1)</sup>	Package Type	Package Drawing	Pins	Package Qty	Eco Plan <sup>(2)</sup>	Lead/Ball Finish	MSL Peak Temp <sup>(3)</sup>
SN74F543DBLE	OBSOLETE	SSOP	DB	24		TBD	Call TI	Call TI
SN74F543DBR	ACTIVE	SSOP	DB	24	2000	Green (RoHS & no Sb/Br)	CU NIPDAU	Level-1-260C-UNLIM
SN74F543DBRE4	ACTIVE	SSOP	DB	24	2000	Green (RoHS & no Sb/Br)	CU NIPDAU	Level-1-260C-UNLIM
SN74F543DBRG4	ACTIVE	SSOP	DB	24	2000	Green (RoHS & no Sb/Br)	CU NIPDAU	Level-1-260C-UNLIM
SN74F543DW	ACTIVE	SOIC	DW	24	25	Green (RoHS & no Sb/Br)	CU NIPDAU	Level-1-260C-UNLIM
SN74F543DWE4	ACTIVE	SOIC	DW	24	25	Green (RoHS & no Sb/Br)	CU NIPDAU	Level-1-260C-UNLIM
SN74F543DWG4	ACTIVE	SOIC	DW	24	25	Green (RoHS & no Sb/Br)	CU NIPDAU	Level-1-260C-UNLIM
SN74F543DWR	ACTIVE	SOIC	DW	24	2000	Green (RoHS & no Sb/Br)	CU NIPDAU	Level-1-260C-UNLIM
SN74F543DWRE4	ACTIVE	SOIC	DW	24	2000	Green (RoHS & no Sb/Br)	CU NIPDAU	Level-1-260C-UNLIM
SN74F543DWRG4	ACTIVE	SOIC	DW	24	2000	Green (RoHS & no Sb/Br)	CU NIPDAU	Level-1-260C-UNLIM
SN74F543NSRE4	ACTIVE	SO	NS	24		TBD	Call TI	Call TI
SN74F543NSRG4	ACTIVE	SO	NS	24		TBD	Call TI	Call TI
SN74F543NT	ACTIVE	PDIP	NT	24	15	Pb-Free (RoHS)	CU NIPDAU	N / A for Pkg Type
SN74F543NTE4	ACTIVE	PDIP	NT	24	15	Pb-Free (RoHS)	CU NIPDAU	N / A for Pkg Type

<sup>(1)</sup> The marketing status values are defined as follows:

**ACTIVE:** Product device recommended for new designs.

**LIFEBUY:** TI has announced that the device will be discontinued, and a lifetime-buy period is in effect.

**NRND:** Not recommended for new designs. Device is in production to support existing customers, but TI does not recommend using this part in a new design.

**PREVIEW:** Device has been announced but is not in production. Samples may or may not be available.

**OBSOLETE:** TI has discontinued the production of the device.

<sup>(2)</sup> Eco Plan - The planned eco-friendly classification: Pb-Free (RoHS), Pb-Free (RoHS Exempt), or Green (RoHS & no Sb/Br) - please check <http://www.ti.com/productcontent> for the latest availability information and additional product content details.

**TBD:** The Pb-Free/Green conversion plan has not been defined.

**Pb-Free (RoHS):** TI's terms "Lead-Free" or "Pb-Free" mean semiconductor products that are compatible with the current RoHS requirements for all 6 substances, including the requirement that lead not exceed 0.1% by weight in homogeneous materials. Where designed to be soldered at high temperatures, TI Pb-Free products are suitable for use in specified lead-free processes.

**Pb-Free (RoHS Exempt):** This component has a RoHS exemption for either 1) lead-based flip-chip solder bumps used between the die and package, or 2) lead-based die adhesive used between the die and leadframe. The component is otherwise considered Pb-Free (RoHS compatible) as defined above.

**Green (RoHS & no Sb/Br):** TI defines "Green" to mean Pb-Free (RoHS compatible), and free of Bromine (Br) and Antimony (Sb) based flame retardants (Br or Sb do not exceed 0.1% by weight in homogeneous material)

<sup>(3)</sup> MSL, Peak Temp. -- The Moisture Sensitivity Level rating according to the JEDEC industry standard classifications, and peak solder temperature.

**Important Information and Disclaimer:** The information provided on this page represents TI's knowledge and belief as of the date that it is provided. TI bases its knowledge and belief on information provided by third parties, and makes no representation or warranty as to the accuracy of such information. Efforts are underway to better integrate information from third parties. TI has taken and continues to take reasonable steps to provide representative and accurate information but may not have conducted destructive testing or chemical analysis on

incoming materials and chemicals. TI and TI suppliers consider certain information to be proprietary, and thus CAS numbers and other limited information may not be available for release.

In no event shall TI's liability arising out of such information exceed the total purchase price of the TI part(s) at issue in this document sold by TI to Customer on an annual basis.

## TAPE AND REEL INFORMATION



### QUADRANT ASSIGNMENTS FOR PIN 1 ORIENTATION IN TAPE



\*All dimensions are nominal

Device	Package Type	Package Drawing	Pins	SPQ	Reel Diameter (mm)	Reel Width W1 (mm)	A0 (mm)	B0 (mm)	K0 (mm)	P1 (mm)	W (mm)	Pin1 Quadrant
SN74F543DBR	SSOP	DB	24	2000	330.0	16.4	8.2	8.8	2.5	12.0	16.0	Q1
SN74F543DWR	SOIC	DW	24	2000	330.0	24.4	10.75	15.7	2.7	12.0	24.0	Q1

**TAPE AND REEL BOX DIMENSIONS**

\*All dimensions are nominal

Device	Package Type	Package Drawing	Pins	SPQ	Length (mm)	Width (mm)	Height (mm)
SN74F543DBR	SSOP	DB	24	2000	346.0	346.0	33.0
SN74F543DWR	SOIC	DW	24	2000	346.0	346.0	41.0

DB (R-PDSO-G\*\*)

PLASTIC SMALL-OUTLINE

28 PINS SHOWN



- NOTES: A. All linear dimensions are in millimeters.  
 B. This drawing is subject to change without notice.  
 C. Body dimensions do not include mold flash or protrusion not to exceed 0,15.  
 D. Falls within JEDEC MO-150





# MECHANICAL DATA

NT (R-PDIP-T\*\*)

PLASTIC DUAL-IN-LINE PACKAGE

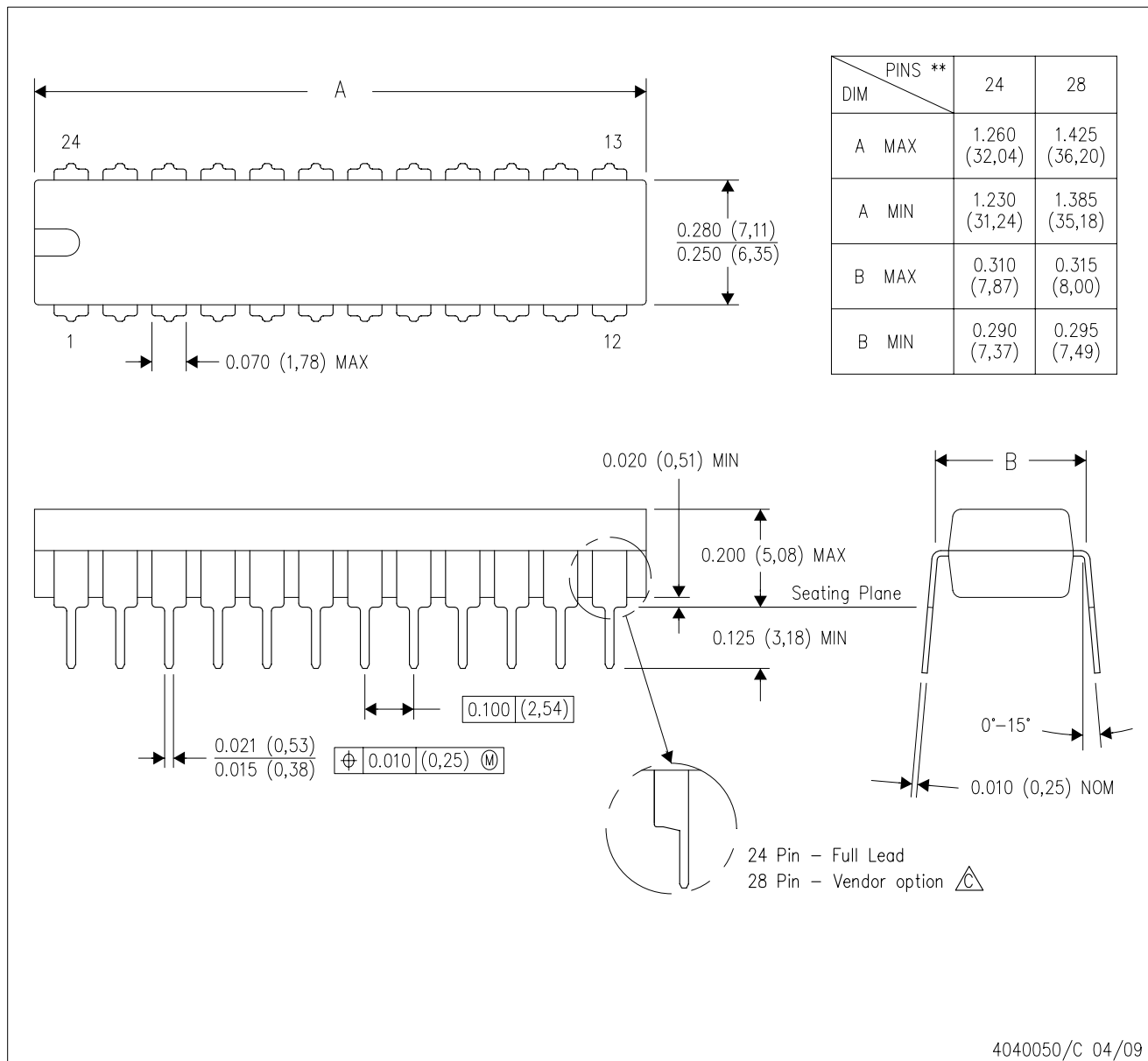
24 PINS SHOWN



- NOTES:
- A. All linear dimensions are in millimeters. Dimensioning and tolerancing per ASME Y14.5M-1994.
  - B. This drawing is subject to change without notice.
  -  The 28 pin end lead shoulder width is a vendor option, either half or full width.



## IMPORTANT NOTICE

Texas Instruments Incorporated and its subsidiaries (TI) reserve the right to make corrections, modifications, enhancements, improvements, and other changes to its products and services at any time and to discontinue any product or service without notice. Customers should obtain the latest relevant information before placing orders and should verify that such information is current and complete. All products are sold subject to TI's terms and conditions of sale supplied at the time of order acknowledgment.

TI warrants performance of its hardware products to the specifications applicable at the time of sale in accordance with TI's standard warranty. Testing and other quality control techniques are used to the extent TI deems necessary to support this warranty. Except where mandated by government requirements, testing of all parameters of each product is not necessarily performed.

TI assumes no liability for applications assistance or customer product design. Customers are responsible for their products and applications using TI components. To minimize the risks associated with customer products and applications, customers should provide adequate design and operating safeguards.

TI does not warrant or represent that any license, either express or implied, is granted under any TI patent right, copyright, mask work right, or other TI intellectual property right relating to any combination, machine, or process in which TI products or services are used. Information published by TI regarding third-party products or services does not constitute a license from TI to use such products or services or a warranty or endorsement thereof. Use of such information may require a license from a third party under the patents or other intellectual property of the third party, or a license from TI under the patents or other intellectual property of TI.

Reproduction of TI information in TI data books or data sheets is permissible only if reproduction is without alteration and is accompanied by all associated warranties, conditions, limitations, and notices. Reproduction of this information with alteration is an unfair and deceptive business practice. TI is not responsible or liable for such altered documentation. Information of third parties may be subject to additional restrictions.

Resale of TI products or services with statements different from or beyond the parameters stated by TI for that product or service voids all express and any implied warranties for the associated TI product or service and is an unfair and deceptive business practice. TI is not responsible or liable for any such statements.

TI products are not authorized for use in safety-critical applications (such as life support) where a failure of the TI product would reasonably be expected to cause severe personal injury or death, unless officers of the parties have executed an agreement specifically governing such use. Buyers represent that they have all necessary expertise in the safety and regulatory ramifications of their applications, and acknowledge and agree that they are solely responsible for all legal, regulatory and safety-related requirements concerning their products and any use of TI products in such safety-critical applications, notwithstanding any applications-related information or support that may be provided by TI. Further, Buyers must fully indemnify TI and its representatives against any damages arising out of the use of TI products in such safety-critical applications.

TI products are neither designed nor intended for use in military/aerospace applications or environments unless the TI products are specifically designated by TI as military-grade or "enhanced plastic." Only products designated by TI as military-grade meet military specifications. Buyers acknowledge and agree that any such use of TI products which TI has not designated as military-grade is solely at the Buyer's risk, and that they are solely responsible for compliance with all legal and regulatory requirements in connection with such use.

TI products are neither designed nor intended for use in automotive applications or environments unless the specific TI products are designated by TI as compliant with ISO/TS 16949 requirements. Buyers acknowledge and agree that, if they use any non-designated products in automotive applications, TI will not be responsible for any failure to meet such requirements.

Following are URLs where you can obtain information on other Texas Instruments products and application solutions:

### Products

Amplifiers	<a href="http://amplifier.ti.com">amplifier.ti.com</a>
Data Converters	<a href="http://dataconverter.ti.com">dataconverter.ti.com</a>
DLP® Products	<a href="http://www.dlp.com">www.dlp.com</a>
DSP	<a href="http://dsp.ti.com">dsp.ti.com</a>
Clocks and Timers	<a href="http://www.ti.com/clocks">www.ti.com/clocks</a>
Interface	<a href="http://interface.ti.com">interface.ti.com</a>
Logic	<a href="http://logic.ti.com">logic.ti.com</a>
Power Mgmt	<a href="http://power.ti.com">power.ti.com</a>
Microcontrollers	<a href="http://microcontroller.ti.com">microcontroller.ti.com</a>
RFID	<a href="http://www.ti-rfid.com">www.ti-rfid.com</a>
RF/IF and ZigBee® Solutions	<a href="http://www.ti.com/lprf">www.ti.com/lprf</a>

### Applications

Audio	<a href="http://www.ti.com/audio">www.ti.com/audio</a>
Automotive	<a href="http://www.ti.com/automotive">www.ti.com/automotive</a>
Broadband	<a href="http://www.ti.com/broadband">www.ti.com/broadband</a>
Digital Control	<a href="http://www.ti.com/digitalcontrol">www.ti.com/digitalcontrol</a>
Medical	<a href="http://www.ti.com/medical">www.ti.com/medical</a>
Military	<a href="http://www.ti.com/military">www.ti.com/military</a>
Optical Networking	<a href="http://www.ti.com/opticalnetwork">www.ti.com/opticalnetwork</a>
Security	<a href="http://www.ti.com/security">www.ti.com/security</a>
Telephony	<a href="http://www.ti.com/telephony">www.ti.com/telephony</a>
Video & Imaging	<a href="http://www.ti.com/video">www.ti.com/video</a>
Wireless	<a href="http://www.ti.com/wireless">www.ti.com/wireless</a>

Mailing Address: Texas Instruments, Post Office Box 655303, Dallas, Texas 75265  
Copyright © 2009, Texas Instruments Incorporated