

SN74F378 HEX D-TYPE FLIP-FLOP WITH CLOCK ENABLE

SDFS030B – D2932, MARCH 1987 – REVISED OCTOBER 1993

- Contains Six D-Type Flip-Flops With Single-Rail Outputs
- Applications Include:
Buffer/Storage Registers
Shift Registers
Pattern Generators
- Buffered Common Enable Input
- Package Options Include Plastic Small-Outline Packages and Standard Plastic 300-mil DIPs

D OR N PACKAGE
(TOP VIEW)

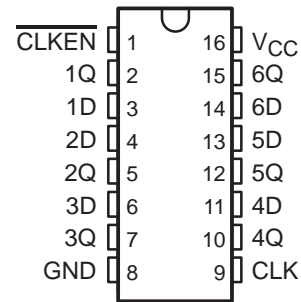

description

The SN74F378 is a positive-edge-triggered D-type flip-flop with a clock enable ($\overline{\text{CLKEN}}$) input. The SN74F378 is similar to the SN74F174 but features a common clock enable instead of a common clear.

Information at the data (D) inputs meeting the setup time requirements is transferred to the Q outputs on the positive-going edge of the clock pulse if $\overline{\text{CLKEN}}$ is low. Clock triggering occurs at a particular voltage level and is not directly related to the positive-going pulse. When the clock (CLK) input is at either the high or low level, the D-input signal has no effect at the output.

The SN74F378 is characterized for operation from 0°C to 70°C.

FUNCTION TABLE
(each flip-flop)

INPUTS			OUTPUT
$\overline{\text{CLKEN}}$	CLK	D	Q
H	X	X	Q_0
L	↑	H	H
L	↑	L	L
X	L	X	Q_0

logic symbol†

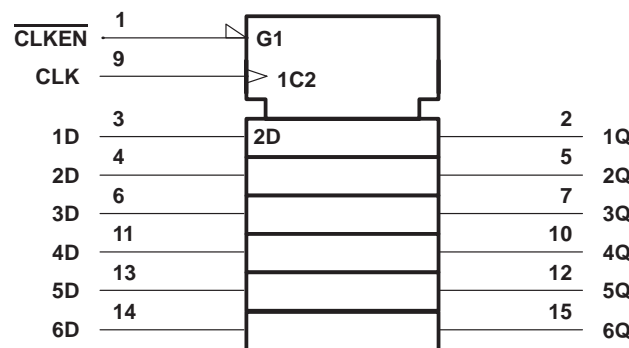

† This symbol is in accordance with ANSI/IEEE Std 91-1984 and IEC Publication 617-12.

SN74F378 HEX D-TYPE FLIP-FLOP WITH CLOCK ENABLE

SDFS030B – D2932, MARCH 1987 – REVISED OCTOBER 1993

logic diagram (positive logic)

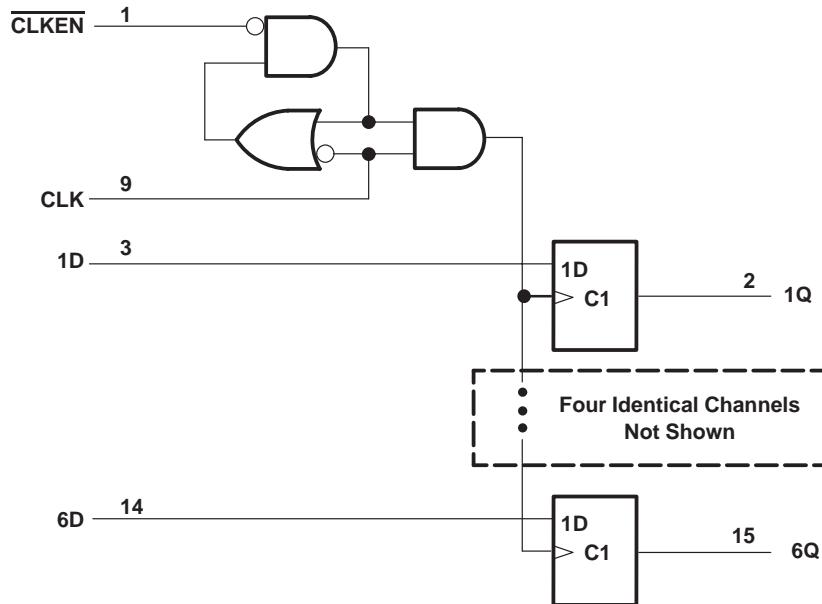

absolute maximum ratings over operating free-air temperature range (unless otherwise noted)[†]

Supply voltage range, V_{CC}	-0.5 V to 7 V
Input voltage range, V_I (see Note 1)	-1.2 V to 7 V
Input current range	-30 mA to 5 mA
Voltage range applied to any output in the high state	-0.5 V to V_{CC}
Current into any output in the low state	40 mA
Operating free-air temperature range	0°C to 70°C
Storage temperature range	-65°C to 150°C

[†] Stresses beyond those listed under "absolute maximum ratings" may cause permanent damage to the device. These are stress ratings only and functional operation of the device at these or any other conditions beyond those indicated under "recommended operating conditions" is not implied. Exposure to absolute-maximum-rated conditions for extended periods may affect device reliability.

NOTE 1: The input-voltage ratings may be exceeded provided the input-current ratings are observed.

recommended operating conditions

		MIN	NOM	MAX	UNIT
V_{CC}	Supply voltage	4.5	5	5.5	V
V_{IH}	High-level input voltage	2			V
V_{IL}	Low-level input voltage			0.8	V
I_{IK}	Input clamp current			-18	mA
I_{OH}	High-level output current			-1	mA
I_{OL}	Low-level output current			20	mA
T_A	Operating free-air temperature	0		70	°C

SN74F378 HEX D-TYPE FLIP-FLOP WITH CLOCK ENABLE

SDFS030B – D2932, MARCH 1987 – REVISED OCTOBER 1993

electrical characteristics over recommended operating free-air temperature range (unless otherwise noted)

PARAMETER	TEST CONDITIONS		MIN	TYP [†]	MAX	UNIT
V_{IK}	$V_{CC} = 4.5\text{ V}$,	$I_I = -18\text{ mA}$			-1.2	V
V_{OH}	$V_{CC} = 4.5\text{ V}$,	$I_{OH} = -1\text{ mA}$	2.5	3.4		V
	$V_{CC} = 4.75\text{ V}$,	$I_{OH} = -1\text{ mA}$	2.7			
V_{OL}	$V_{CC} = 4.5\text{ V}$,	$I_{OL} = 20\text{ mA}$		0.3	0.5	V
I_I	$V_{CC} = 5.5\text{ V}$,	$V_I = 7\text{ V}$			0.1	mA
I_{IH}	$V_{CC} = 5.5\text{ V}$,	$V_I = 2.7\text{ V}$			20	μA
I_{IL}	$V_{CC} = 5.5\text{ V}$,	$V_I = 0.5\text{ V}$			-0.6	mA
I_{OS}^{\ddagger}	$V_{CC} = 5.5\text{ V}$,	$V_O = 0$	-60		-150	mA
I_{CC}	$V_{CC} = 5.5\text{ V}$,	See Note 2		30	45	mA

[†] All typical values are at $V_{CC} = 5\text{ V}$, $T_A = 25^\circ\text{C}$.

[‡] Not more than one output should be shorted at a time, and the duration of the short circuit should not exceed one second.

NOTE 2: I_{CC} is measured with all outputs open, all data inputs and the enable input grounded, and the clock input at 4.5 V after being momentarily grounded.

timing requirements

		$V_{CC} = 5\text{ V}$, $T_A = 25^\circ\text{C}$		$V_{CC} = 4.5\text{ V to } 5.5\text{ V}$, $T_A = \text{MIN to MAX}^{\S}$		UNIT
		MIN	MAX	MIN	MAX	
f_{clock}	Clock frequency	0	110	0	110	MHz
t_w	Pulse duration	CLK high	4	4		ns
		CLK low	6	6		
t_{su}	Setup time before CLK \uparrow	Data high or low	5	5		ns
		CLKEN high	3.5	3.5		
		CLKEN low	5	5		
t_h	Hold time after CLK \uparrow	Data high or low	1	1		ns
		CLKEN high or low	0	0		

switching characteristics (see Note 3)

PARAMETER	FROM (INPUT)	TO (OUTPUT)	$V_{CC} = 5\text{ V}$, $C_L = 50\text{ pF}$, $R_L = 500\ \Omega$, $T_A = 25^\circ\text{C}$			$V_{CC} = 4.5\text{ V to } 5.5\text{ V}$, $C_L = 50\text{ pF}$, $R_L = 500\ \Omega$, $T_A = \text{MIN to MAX}^{\S}$		UNIT
			MIN	TYP	MAX	MIN	MAX	
f_{max}			110	125		110		MHz
t_{PLH}	CLK	Any Q	3.3	4.5	6.1	3.1	6.7	ns
t_{PHL}			3	4.2	6	2.9	6.1	

^{\S} For conditions shown as MIN or MAX, use the appropriate value specified under recommended operating conditions.

NOTE 3: Load circuits and waveforms are shown in Section 1.

IMPORTANT NOTICE

Texas Instruments and its subsidiaries (TI) reserve the right to make changes to their products or to discontinue any product or service without notice, and advise customers to obtain the latest version of relevant information to verify, before placing orders, that information being relied on is current and complete. All products are sold subject to the terms and conditions of sale supplied at the time of order acknowledgement, including those pertaining to warranty, patent infringement, and limitation of liability.

TI warrants performance of its semiconductor products to the specifications applicable at the time of sale in accordance with TI's standard warranty. Testing and other quality control techniques are utilized to the extent TI deems necessary to support this warranty. Specific testing of all parameters of each device is not necessarily performed, except those mandated by government requirements.

CERTAIN APPLICATIONS USING SEMICONDUCTOR PRODUCTS MAY INVOLVE POTENTIAL RISKS OF DEATH, PERSONAL INJURY, OR SEVERE PROPERTY OR ENVIRONMENTAL DAMAGE ("CRITICAL APPLICATIONS"). TI SEMICONDUCTOR PRODUCTS ARE NOT DESIGNED, AUTHORIZED, OR WARRANTED TO BE SUITABLE FOR USE IN LIFE-SUPPORT DEVICES OR SYSTEMS OR OTHER CRITICAL APPLICATIONS. INCLUSION OF TI PRODUCTS IN SUCH APPLICATIONS IS UNDERSTOOD TO BE FULLY AT THE CUSTOMER'S RISK.

In order to minimize risks associated with the customer's applications, adequate design and operating safeguards must be provided by the customer to minimize inherent or procedural hazards.

TI assumes no liability for applications assistance or customer product design. TI does not warrant or represent that any license, either express or implied, is granted under any patent right, copyright, mask work right, or other intellectual property right of TI covering or relating to any combination, machine, or process in which such semiconductor products or services might be or are used. TI's publication of information regarding any third party's products or services does not constitute TI's approval, warranty or endorsement thereof.