

SN54F299, SN74F299

8-BIT UNIVERSAL SHIFT/STORAGE REGISTERS WITH 3-STATE OUTPUTS

The SN54F299 is obsolete and no longer supplied.

SDFS071B – MARCH 1987 – REVISED APRIL 2004

- **Four Modes of Operation:**
 - Hold (Store)
 - Shift Right
 - Shift Left
 - Load Data
- **Operates With Outputs Enabled or at High Impedance**
- **3-State Outputs Drive Bus Lines Directly**
- **Can Be Cascaded for N-Bit Word Lengths**
- **Direct Overriding Clear**
- **Applications:**
 - Stacked or Pushdown Registers
 - Buffer Storage
 - Accumulator Registers

description/ordering information

These 8-bit universal shift/storage registers feature multiplexed I/O ports to achieve full 8-bit data handling in a single 20-pin package. Two function-select (S_0, S_1) inputs and two output-enable ($\overline{OE1}, \overline{OE2}$) inputs can be used to choose the modes of operation listed in the function table.

Synchronous parallel loading is accomplished by taking both S_0 and S_1 high. This places the 3-state outputs in a high-impedance state and permits data that is applied on the I/O ports to be clocked into the register. Reading out of the register can be accomplished while the outputs are enabled in any mode. Clearing occurs when the clear (\overline{CLR}) input is low. Taking either $\overline{OE1}$ or $\overline{OE2}$ high disables the outputs but has no effect on clearing, shifting, or storage of data.

SN54F299 . . . J PACKAGE
SN74F299 . . . DW, N, OR NS PACKAGE
(TOP VIEW)



SN54F299 . . . FK PACKAGE
(TOP VIEW)

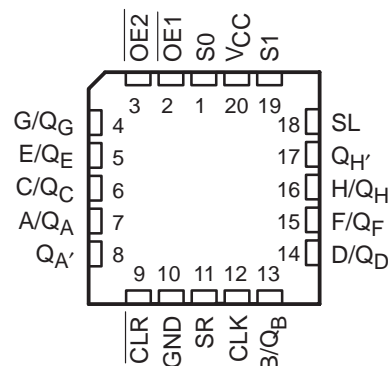

ORDERING INFORMATION

T _A	PACKAGE†		ORDERABLE PART NUMBER	TOP-SIDE MARKING
0°C to 70°C	PDIP – N	Tube of 20	SN74F299N	SN74F299N
	SOIC – DW	Tube of 25	SN74F299DW	F299
		Reel of 2000	SN74F299DWR	
	SOP – NS	Reel of 2000	SN74F299NSR	74F299

† Package drawings, standard packing quantities, thermal data, symbolization, and PCB design guidelines are available at www.ti.com/sc/package.



Please be aware that an important notice concerning availability, standard warranty, and use in critical applications of Texas Instruments semiconductor products and disclaimers thereto appears at the end of this data sheet.

PRODUCTION DATA information is current as of publication date. Products conform to specifications per the terms of Texas Instruments standard warranty. Production processing does not necessarily include testing of all parameters.



POST OFFICE BOX 655303 • DALLAS, TEXAS 75265

Copyright © 2004, Texas Instruments Incorporated

SN54F299, SN74F299

8-BIT UNIVERSAL SHIFT/STORAGE REGISTERS

WITH 3-STATE OUTPUTS

SDFS071B – MARCH 1987 – REVISED APRIL 2004

The SN54F299 is obsolete and no longer supplied.

FUNCTION TABLE

MODE	INPUTS								I/O PORTS								OUTPUTS	
	CLR	S1	S0	OE1†	OE2†	CLK	SL	SR	A/Q _A	B/Q _B	C/Q _C	D/Q _D	E/Q _E	F/Q _F	G/Q _G	H/Q _H	Q _A '	Q _H '
Clear	L	X	L	L	L	X	X	X	L	L	L	L	L	L	L	L	L	L
	L	L	X	L	L	X	X	X	L	L	L	L	L	L	L	L	L	L
	L	H	H	X	X	X	X	X	X	X	X	X	X	X	X	X	L	L
Hold	H	L	L	L	L	X	X	X	Q _{A0}	Q _{B0}	Q _{C0}	Q _{D0}	Q _{E0}	Q _{F0}	Q _{G0}	Q _{H0}	Q _{A0}	Q _{H0}
	H	X	X	L	L	L	X	X	Q _{A0}	Q _{B0}	Q _{C0}	Q _{D0}	Q _{E0}	Q _{F0}	Q _{G0}	Q _{H0}	Q _{A0}	Q _{H0}
Shift Right	H	L	H	L	L	↑	X	H	H	Q _{An}	Q _{Bn}	Q _{Cn}	Q _{Dn}	Q _{En}	Q _{Fn}	Q _{Gn}	H	Q _{Gn}
	H	L	H	L	L	↑	X	L	L	Q _{An}	Q _{Bn}	Q _{Cn}	Q _{Dn}	Q _{En}	Q _{Fn}	Q _{Gn}	L	Q _{Gn}
Shift Left	H	H	L	L	L	↑	H	X	Q _{Bn}	Q _{Cn}	Q _{Dn}	Q _{En}	Q _{Fn}	Q _{Gn}	Q _{Hn}	H	Q _{Bn}	H
	H	H	L	L	L	↑	L	X	Q _{Bn}	Q _{Cn}	Q _{Dn}	Q _{En}	Q _{Fn}	Q _{Gn}	Q _{Hn}	L	Q _{Bn}	L
Load	H	H	H	X	X	↑	X	X	a	b	c	d	e	f	g	h	a	h

NOTE: a . . . h = the level of the steady-state input at inputs A through H, respectively. This data is loaded into the flip-flops while the flip-flop outputs are isolated from the I/O terminals.

† When one or both output-enable inputs are high, the eight I/O terminals are disabled to the high-impedance state; however, sequential operation or clearing of the register is not affected.

logic diagram (positive logic)

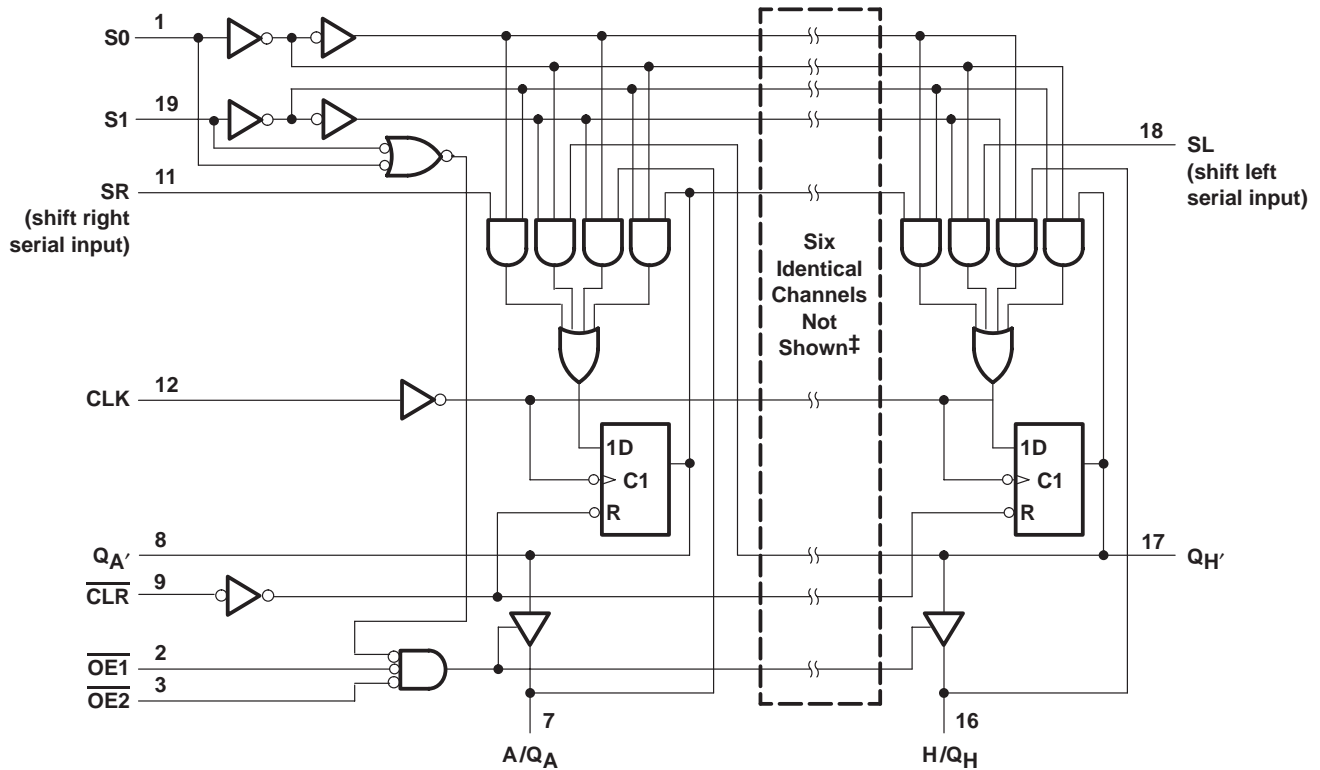

‡ I/O ports not shown: B/Q_B (13), C/Q_C (6), D/Q_D (14), E/Q_E (5), F/Q_F (15), and G/Q_G (4).

The SN54F299 is obsolete and no longer supplied.

SN54F299, SN74F299 8-BIT UNIVERSAL SHIFT/STORAGE REGISTERS WITH 3-STATE OUTPUTS

SDFS071B – MARCH 1987 – REVISED APRIL 2004

absolute maximum ratings over operating free-air temperature range (unless otherwise noted)†

Supply voltage range, V_{CC}	–0.5 V to 7 V
Input voltage range, V_I (see Note 1)	–1.2 V to 7 V
Input current range	–30 mA to 5 mA
Voltage range applied to any output in the disabled or power-off state	–0.5 V to 5.5 V
Voltage range applied to any output in the high state	–0.5 V to V_{CC}
Current into any output in the low state: $Q_{A'}$ or $Q_{H'}$	40 mA
SN54F299 (Q_A thru Q_H)	40 mA
SN74F299 (Q_A thru Q_H)	48 mA
Package thermal impedance, θ_{JA} (see Note 2): DW package	58°C/W
N package	69°C/W
NS package	60°C/W
Storage temperature range, T_{stg}	–65°C to 150°C

† Stresses beyond those listed under “absolute maximum ratings” may cause permanent damage to the device. These are stress ratings only, and functional operation of the device at these or any other conditions beyond those indicated under “recommended operating conditions” is not implied. Exposure to absolute-maximum-rated conditions for extended periods may affect device reliability.

- NOTES: 1. The input voltage ratings may be exceeded provided the input current ratings are observed.
2. The package thermal impedance is calculated in accordance with JESD 51-7.

recommended operating conditions (see Note 3)

		SN54F299			SN74F299			UNIT
		MIN	NOM	MAX	MIN	NOM	MAX	
V_{CC}	Supply voltage	4.5	5	5.5	4.5	5	5.5	V
V_{IH}	High-level input voltage	2			2			V
V_{IL}	Low-level input voltage			0.8			0.8	V
I_{IK}	Input clamp current			–18			–18	mA
I_{OH}	High-level output current	$Q_{A'}$ or $Q_{H'}$		–1	$Q_{A'}$ or $Q_{H'}$		–1	mA
		Q_A thru Q_H		–3	Q_A thru Q_H		–3	
I_{OL}	Low-level output current	$Q_{A'}$ or $Q_{H'}$		20	$Q_{A'}$ or $Q_{H'}$		20	mA
		Q_A thru Q_H		20	Q_A thru Q_H		24	
T_A	Operating free-air temperature	–55		125	0		70	°C

NOTE 3: All unused inputs of the device must be held at V_{CC} or GND to ensure proper device operation. Refer to the TI application report, *Implications of Slow or Floating CMOS Inputs*, literature number SCBA004.

SN54F299, SN74F299

8-BIT UNIVERSAL SHIFT/STORAGE REGISTERS

WITH 3-STATE OUTPUTS

SDFS071B – MARCH 1987 – REVISED APRIL 2004

The SN54F299 is obsolete and no longer supplied.

electrical characteristics over recommended operating free-air temperature range (unless otherwise noted)

PARAMETER		TEST CONDITIONS		SN54F299			SN74F299			UNIT
				MIN	TYP†	MAX	MIN	TYP†	MAX	
V_{IK}		$V_{CC} = 4.5 V, I_I = -18 mA$		-1.2			-1.2			V
V_{OH}	Q_A' or Q_H'	$V_{CC} = 4.5 V$	$I_{OH} = -1 mA$	2.5	3.4		2.5	3.4	V	
	Q_A thru Q_H		$I_{OH} = -1 mA$	2.5	3.4		2.5	3.4		
			$I_{OH} = -3 mA$	2.4	3.3		2.4	3.3		
Any output		$V_{CC} = 4.75 V,$	$I_{OH} = -1 mA$ to $-3 mA$				2.7			
V_{OL}	Q_A' or Q_H'	$V_{CC} = 4.5 V$	$I_{OL} = 20 mA$	0.3 0.5			0.3 0.5		V	
	Q_A thru Q_H		$I_{OL} = 20 mA$	0.3 0.5						
			$I_{OL} = 24 mA$				0.35 0.5			
I_I	A thru H	$V_{CC} = 5.5 V$	$V_I = 5.5 V$	1			1			mA
	Any other		$V_I = 7 V$	0.1			0.1			
$I_{IH}‡$	A thru H	$V_{CC} = 5.5 V,$	$V_I = 2.7 V$	70			70			μA
	Any other			20			20			
$I_{IL}‡$	A thru H	$V_{CC} = 5.5 V,$	$V_I = 0.5 V$	-0.65			-0.65			mA
	S0 or S1			-1.2			-1.2			
	Any other			-0.6			-0.6			
$I_{OS}§$		$V_{CC} = 5.5 V,$	$V_O = 0$	-60	-150		-60	-150	mA	
I_{CC}		$V_{CC} = 5.5 V,$	See Note 4	68	95		68	95	mA	

† All typical values are at $V_{CC} = 5 V, T_A = 25^\circ C$.

‡ For I/O ports (Q_A thru Q_H), the parameters I_{IH} and I_{IL} include the off-state output current.

§ Not more than one output should be shorted at a time, and the duration of the short circuit should not exceed one second.

NOTE 4: I_{CC} is measured with $\overline{OE1}, \overline{OE2},$ and CLK at 4.5 V.

timing requirements over recommended ranges of supply voltage and operating free-air temperature (unless otherwise noted)

				$V_{CC} = 5 V,$ $T_A = 25^\circ C$		SN54F299	SN74F299	UNIT
				'F299				
				MIN	MAX	MIN	MAX	
f_{clock}	Clock frequency			70		65	70	MHz
t_w	Pulse duration		CLK high or low	7		8	7	ns
			\overline{CLR} low	7		8	7	
t_{su}	Setup time before CLK↑	S0 or S1	High or low	8.5	9.5	8.5	ns	
		A/ Q_A thru H/ $Q_H, SR,$ or SL	High or low	5.5	6.5	5.5		
	Inactive-state setup time before CLK↑†	\overline{CLR}	High	7	13	7		
t_h	Hold time after CLK↑		S0 or S1	High or low	0	0	0	ns
			A/ Q_A thru H/ $Q_H, SR,$ or SL	High or low	2	2	2	

† Inactive-state setup time also is referred to as recovery time.



The SN54F299 is obsolete and no longer supplied.

SN54F299, SN74F299 8-BIT UNIVERSAL SHIFT/STORAGE REGISTERS WITH 3-STATE OUTPUTS

SDFS071B – MARCH 1987 – REVISED APRIL 2004

switching characteristics (see Figure 1)

PARAMETER	FROM (INPUT)	TO (OUTPUT)	V _{CC} = 5 V, C _L = 50 pF, R _L = 500 Ω, T _A = 25°C			V _{CC} = 4.5 V to 5.5 V, C _L = 50 pF, R _L = 500 Ω, T _A = MIN to MAX†				UNIT
			'F299			SN54F299		SN74F299		
			MIN	TYP	MAX	MIN	MAX	MIN	MAX	
f _{max}			70	100		65		70	MHz	
t _{PLH}	CLK	Q _A ' or Q _H '	3.2	6.6	9	2.7	10.5	3.2	10	ns
t _{PHL}			2.7	6.1	8.5	2.2	10	2.7	9.5	
t _{PLH}	CLK	Q _A thru Q _H	3.2	6.6	9	2.7	11	3.2	10	ns
t _{PHL}			4.2	8.1	11	3.7	12.5	4.2	12	
t _{PHL}	$\overline{\text{CLR}}$	Q _A ' or Q _H '	3.7	7.1	9.5	3.2	11.5	3.7	10.5	ns
		Q _A thru Q _H	5.7	10.6	14	5	15.5	5.7	15	
t _{PZH}	$\overline{\text{OE1}}$ or $\overline{\text{OE2}}$	Q _A thru Q _H	2.7	5.6	8	2.2	10.5	2.7	9	ns
t _{PZL}			3.2	6.6	10	2.7	12	3.2	11	
t _{PHZ}	$\overline{\text{OE1}}$ or $\overline{\text{OE2}}$	Q _A thru Q _H	1.7	4.1	6	1.7	9	1.7	7	ns
t _{PLZ}			1.2	3.6	5.5	1.2	7.5	1.2	6.5	

† For conditions shown as MIN or MAX, use the appropriate value specified under recommended operating conditions.

SN54F299, SN74F299 8-BIT UNIVERSAL SHIFT/STORAGE REGISTERS WITH 3-STATE OUTPUTS

SDFS071B – MARCH 1987 – REVISED APRIL 2004

The SN54F299 is obsolete and no longer supplied.

PARAMETER MEASUREMENT INFORMATION

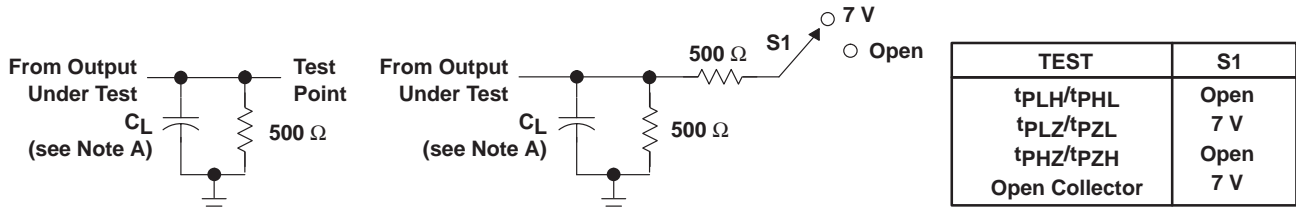

LOAD CIRCUIT FOR
TOTEM-POLE OUTPUTS

LOAD CIRCUIT FOR
3-STATE AND OPEN-DRAIN OUTPUTS

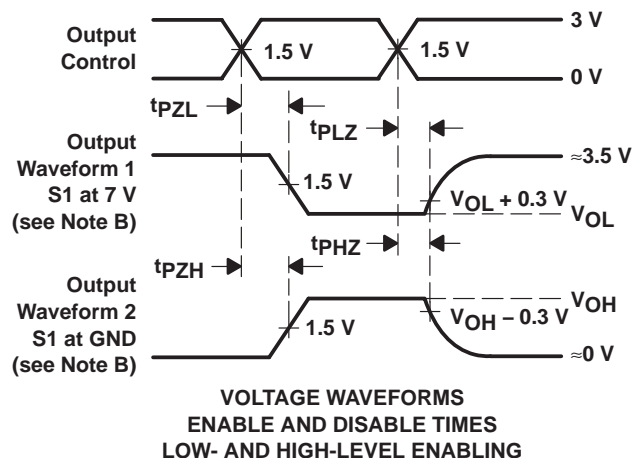
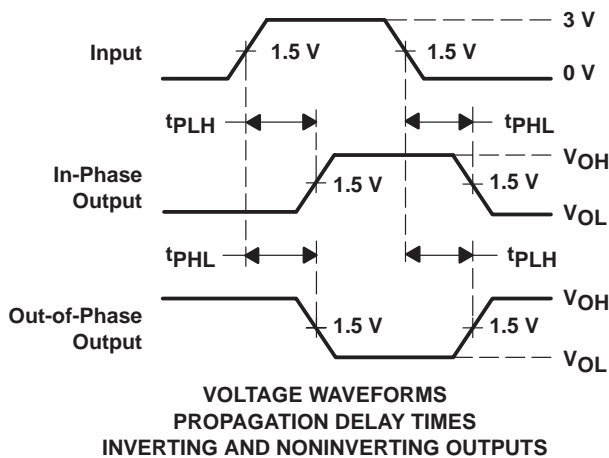
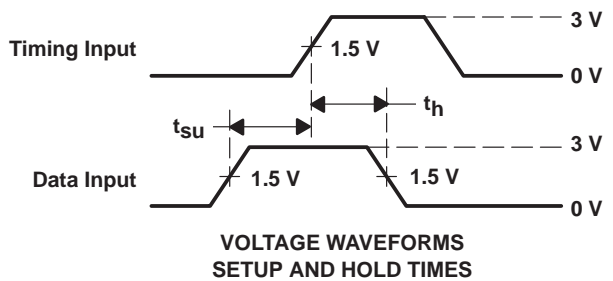
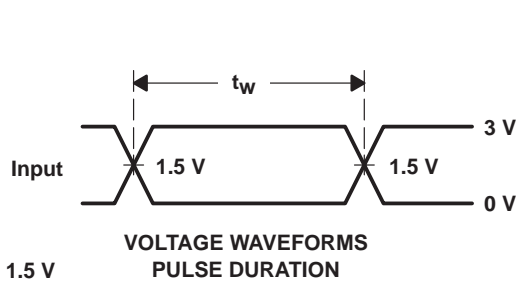

- NOTES:
- A. C_L includes probe and jig capacitance.
 - B. Waveform 1 is for an output with internal conditions such that the output is low, except when disabled by the output control. Waveform 2 is for an output with internal conditions such that the output is high, except when disabled by the output control.
 - C. All input pulses are supplied by generators having the following characteristics: $PRR \leq 1$ MHz, $Z_O = 50 \Omega$, $t_r \leq 2.5$ ns, $t_f \leq 2.5$ ns, duty cycle = 50%.
 - D. The outputs are measured one at a time, with one input transition per measurement.

Figure 1. Load Circuit and Voltage Waveforms

PACKAGING INFORMATION

Orderable Device	Status ⁽¹⁾	Package Type	Package Drawing	Pins	Package Qty	Eco Plan ⁽²⁾	Lead/ Ball Finish	MSL Peak Temp ⁽³⁾	Samples (Requires Login)
SN74F299DW	ACTIVE	SOIC	DW	20	25	Green (RoHS & no Sb/Br)	CU NIPDAU	Level-1-260C-UNLIM	
SN74F299DWG4	ACTIVE	SOIC	DW	20	25	Green (RoHS & no Sb/Br)	CU NIPDAU	Level-1-260C-UNLIM	
SN74F299DWR	ACTIVE	SOIC	DW	20	2000	Green (RoHS & no Sb/Br)	CU NIPDAU	Level-1-260C-UNLIM	
SN74F299DWRE4	ACTIVE	SOIC	DW	20	2000	Green (RoHS & no Sb/Br)	CU NIPDAU	Level-1-260C-UNLIM	
SN74F299DWRG4	ACTIVE	SOIC	DW	20	2000	Green (RoHS & no Sb/Br)	CU NIPDAU	Level-1-260C-UNLIM	
SN74F299N	ACTIVE	PDIP	N	20	20	Pb-Free (RoHS)	CU NIPDAU	N / A for Pkg Type	
SN74F299N3	OBSOLETE	PDIP	N	20		TBD	Call TI	Call TI	
SN74F299NE4	ACTIVE	PDIP	N	20	20	Pb-Free (RoHS)	CU NIPDAU	N / A for Pkg Type	
SN74F299NSRE4	ACTIVE	SO	NS	20		TBD	Call TI	Call TI	
SN74F299NSRG4	ACTIVE	SO	NS	20		TBD	Call TI	Call TI	

⁽¹⁾ The marketing status values are defined as follows:

ACTIVE: Product device recommended for new designs.

LIFEBUY: TI has announced that the device will be discontinued, and a lifetime-buy period is in effect.

NRND: Not recommended for new designs. Device is in production to support existing customers, but TI does not recommend using this part in a new design.

PREVIEW: Device has been announced but is not in production. Samples may or may not be available.

OBSOLETE: TI has discontinued the production of the device.

⁽²⁾ Eco Plan - The planned eco-friendly classification: Pb-Free (RoHS), Pb-Free (RoHS Exempt), or Green (RoHS & no Sb/Br) - please check <http://www.ti.com/productcontent> for the latest availability information and additional product content details.

TBD: The Pb-Free/Green conversion plan has not been defined.

Pb-Free (RoHS): TI's terms "Lead-Free" or "Pb-Free" mean semiconductor products that are compatible with the current RoHS requirements for all 6 substances, including the requirement that lead not exceed 0.1% by weight in homogeneous materials. Where designed to be soldered at high temperatures, TI Pb-Free products are suitable for use in specified lead-free processes.

Pb-Free (RoHS Exempt): This component has a RoHS exemption for either 1) lead-based flip-chip solder bumps used between the die and package, or 2) lead-based die adhesive used between the die and leadframe. The component is otherwise considered Pb-Free (RoHS compatible) as defined above.

Green (RoHS & no Sb/Br): TI defines "Green" to mean Pb-Free (RoHS compatible), and free of Bromine (Br) and Antimony (Sb) based flame retardants (Br or Sb do not exceed 0.1% by weight in homogeneous material)

⁽³⁾ MSL, Peak Temp. -- The Moisture Sensitivity Level rating according to the JEDEC industry standard classifications, and peak solder temperature.

Important Information and Disclaimer: The information provided on this page represents TI's knowledge and belief as of the date that it is provided. TI bases its knowledge and belief on information provided by third parties, and makes no representation or warranty as to the accuracy of such information. Efforts are underway to better integrate information from third parties. TI has taken and continues to take reasonable steps to provide representative and accurate information but may not have conducted destructive testing or chemical analysis on incoming materials and chemicals. TI and TI suppliers consider certain information to be proprietary, and thus CAS numbers and other limited information may not be available for release.

In no event shall TI's liability arising out of such information exceed the total purchase price of the TI part(s) at issue in this document sold by TI to Customer on an annual basis.

TAPE AND REEL INFORMATION

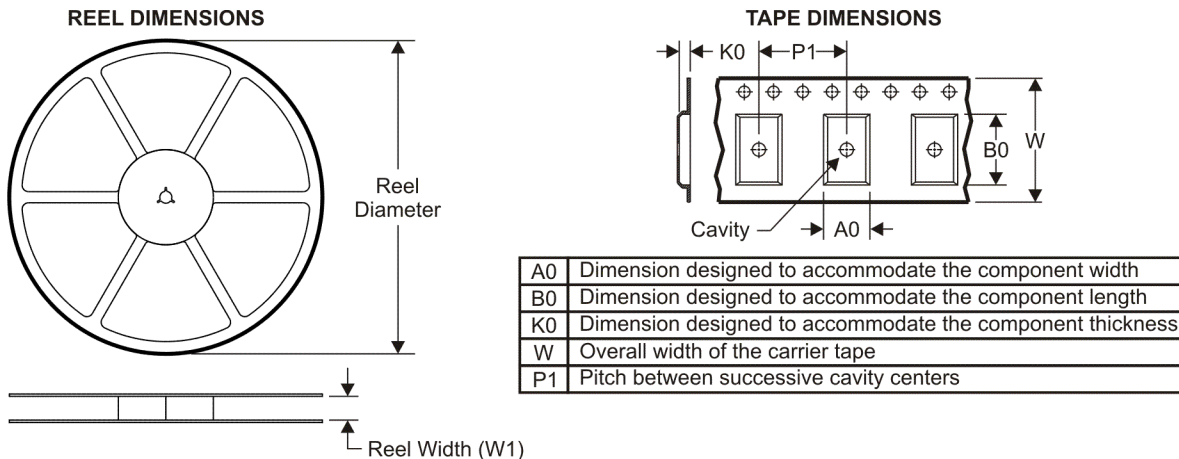

QUADRANT ASSIGNMENTS FOR PIN 1 ORIENTATION IN TAPE

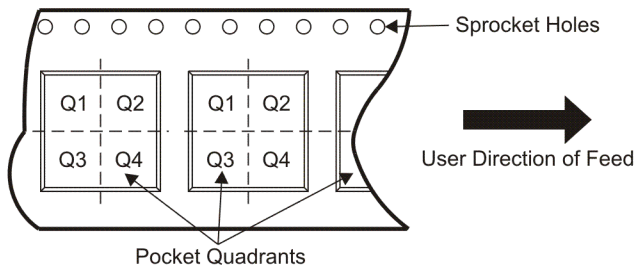

*All dimensions are nominal

Device	Package Type	Package Drawing	Pins	SPQ	Reel Diameter (mm)	Reel Width W1 (mm)	A0 (mm)	B0 (mm)	K0 (mm)	P1 (mm)	W (mm)	Pin1 Quadrant
SN74F299DWR	SOIC	DW	20	2000	330.0	24.4	10.8	13.0	2.7	12.0	24.0	Q1

TAPE AND REEL BOX DIMENSIONS

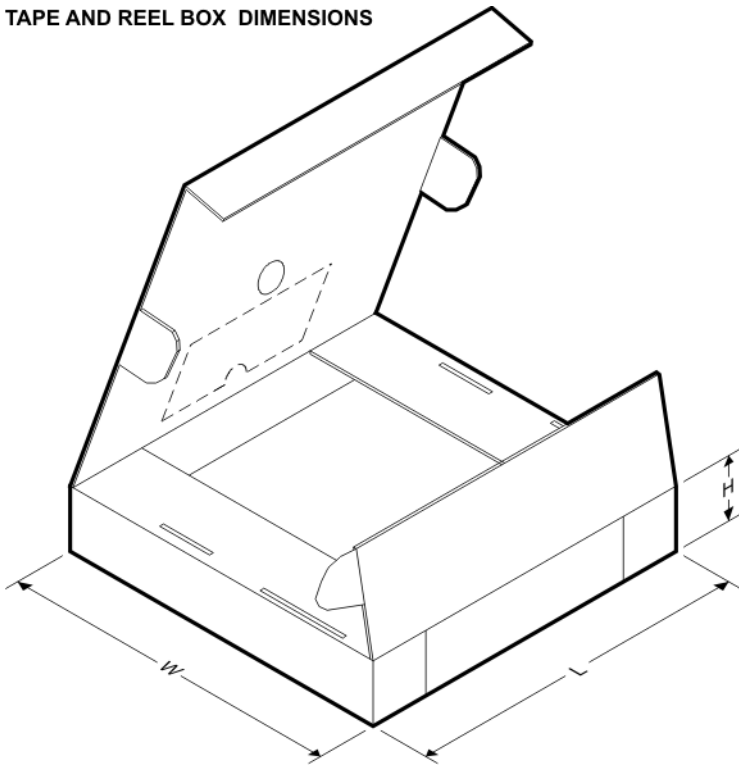

*All dimensions are nominal

Device	Package Type	Package Drawing	Pins	SPQ	Length (mm)	Width (mm)	Height (mm)
SN74F299DWR	SOIC	DW	20	2000	346.0	346.0	41.0

N (R-PDIP-T**)

PLASTIC DUAL-IN-LINE PACKAGE

16 PINS SHOWN

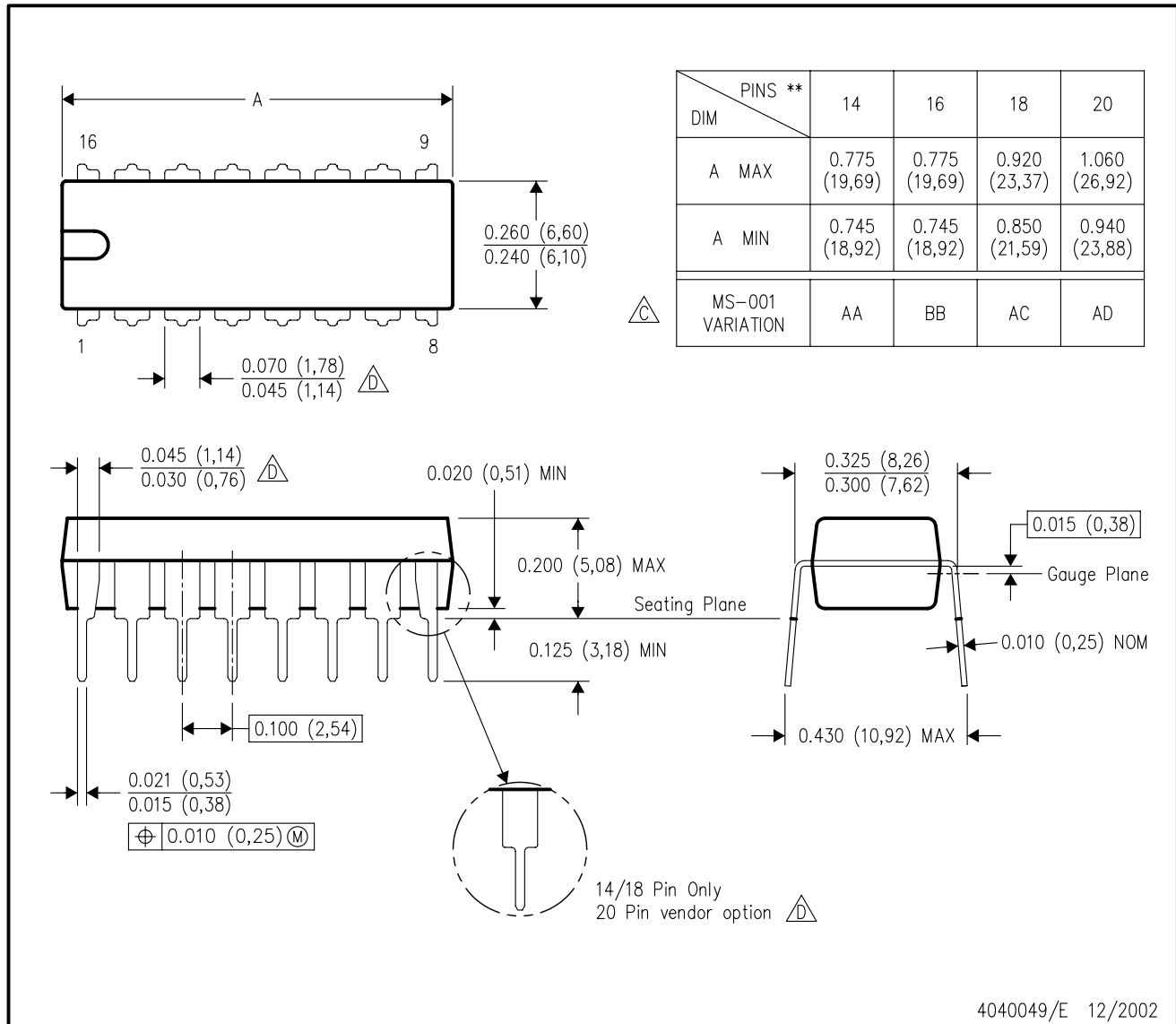

- NOTES:
- A. All linear dimensions are in inches (millimeters).
 - B. This drawing is subject to change without notice.
 - Falls within JEDEC MS-001, except 18 and 20 pin minimum body length (Dim A).
 - The 20 pin end lead shoulder width is a vendor option, either half or full width.

DW (R-PDSO-G20)

PLASTIC SMALL OUTLINE

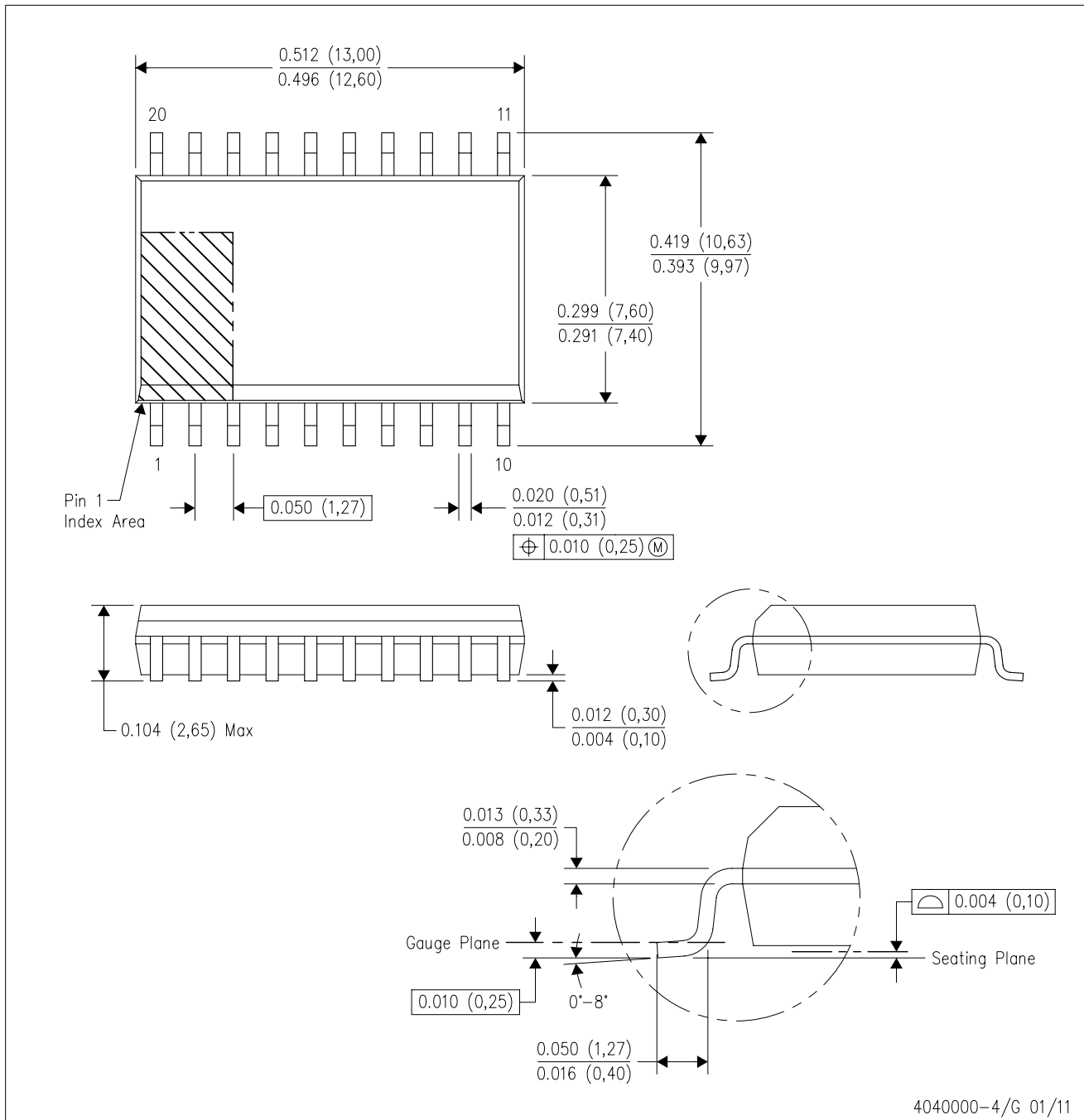

- NOTES:
- A. All linear dimensions are in inches (millimeters). Dimensioning and tolerancing per ASME Y14.5M-1994.
 - B. This drawing is subject to change without notice.
 - C. Body dimensions do not include mold flash or protrusion not to exceed 0.006 (0,15).
 - D. Falls within JEDEC MS-013 variation AC.

DW (R-PDSO-G20)

PLASTIC SMALL OUTLINE

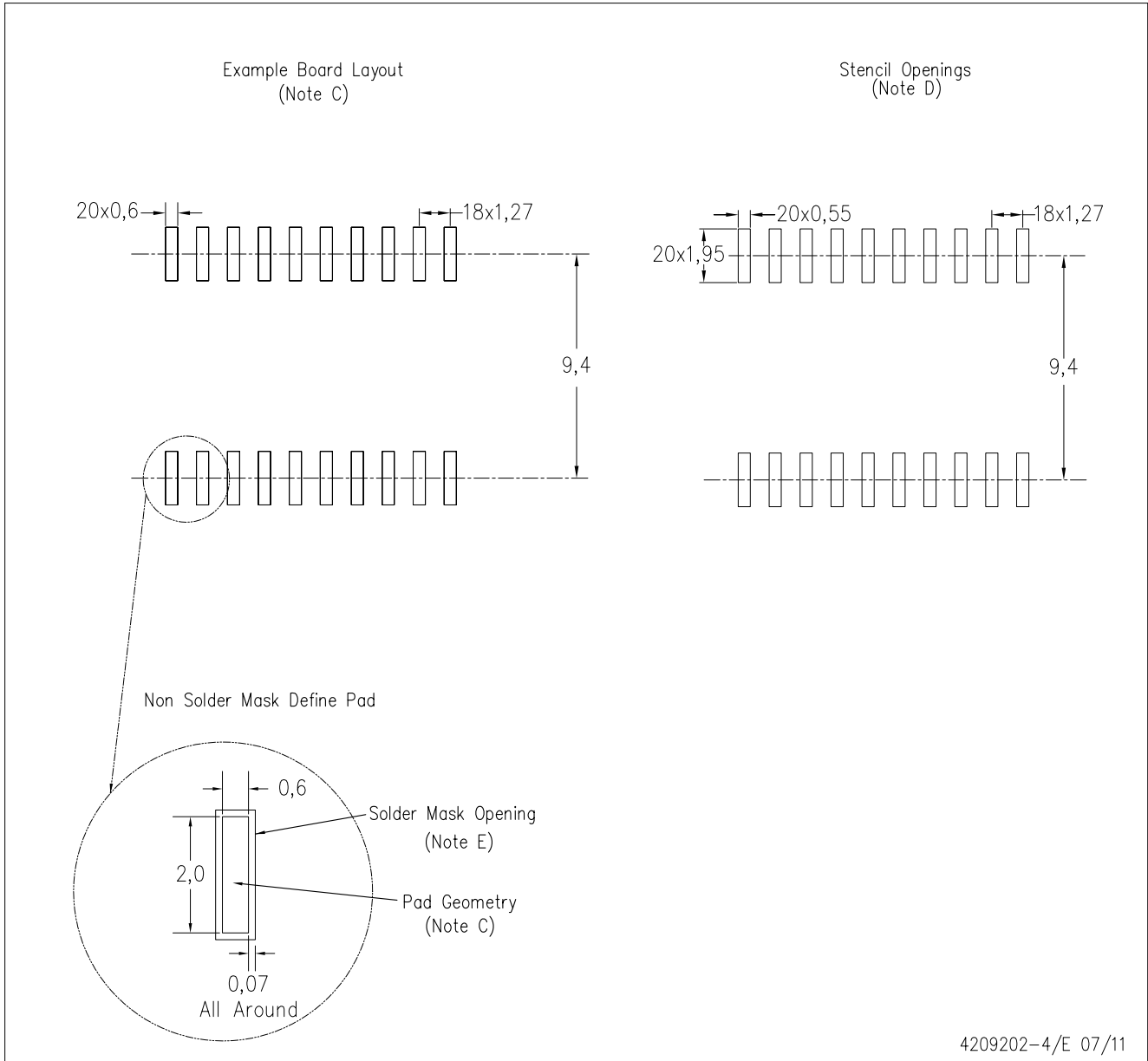

4209202-4/E 07/11

- NOTES:
- A. All linear dimensions are in millimeters.
 - B. This drawing is subject to change without notice.
 - C. Refer to IPC7351 for alternate board design.
 - D. Laser cutting apertures with trapezoidal walls and also rounding corners will offer better paste release. Customers should contact their board assembly site for stencil design recommendations. Refer to IPC-7525
 - E. Customers should contact their board fabrication site for solder mask tolerances between and around signal pads.

MECHANICAL DATA

NS (R-PDSO-G**)

PLASTIC SMALL-OUTLINE PACKAGE

14-PINS SHOWN

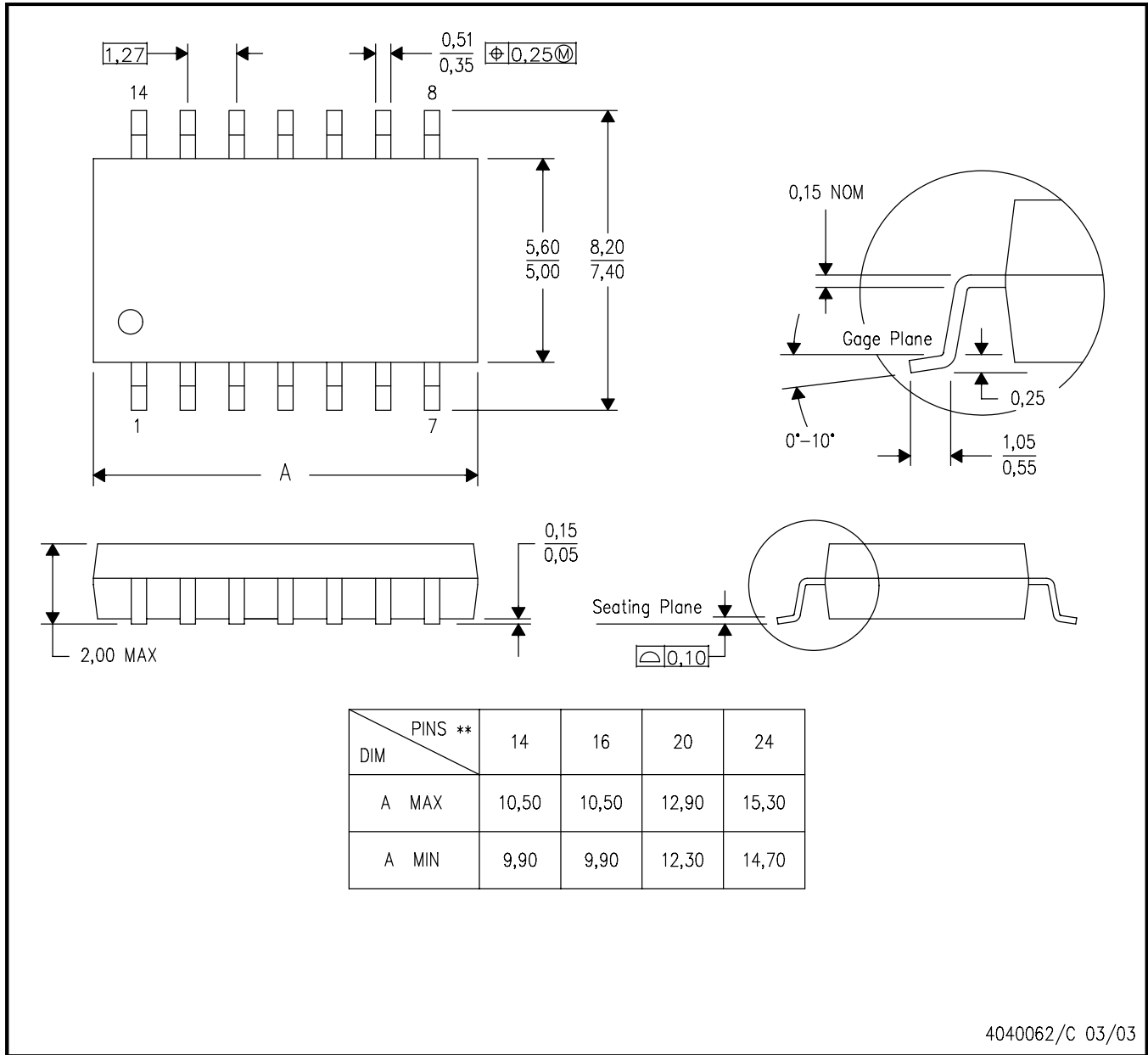

- NOTES:
- A. All linear dimensions are in millimeters.
 - B. This drawing is subject to change without notice.
 - C. Body dimensions do not include mold flash or protrusion, not to exceed 0,15.

IMPORTANT NOTICE

Texas Instruments Incorporated and its subsidiaries (TI) reserve the right to make corrections, modifications, enhancements, improvements, and other changes to its products and services at any time and to discontinue any product or service without notice. Customers should obtain the latest relevant information before placing orders and should verify that such information is current and complete. All products are sold subject to TI's terms and conditions of sale supplied at the time of order acknowledgment.

TI warrants performance of its hardware products to the specifications applicable at the time of sale in accordance with TI's standard warranty. Testing and other quality control techniques are used to the extent TI deems necessary to support this warranty. Except where mandated by government requirements, testing of all parameters of each product is not necessarily performed.

TI assumes no liability for applications assistance or customer product design. Customers are responsible for their products and applications using TI components. To minimize the risks associated with customer products and applications, customers should provide adequate design and operating safeguards.

TI does not warrant or represent that any license, either express or implied, is granted under any TI patent right, copyright, mask work right, or other TI intellectual property right relating to any combination, machine, or process in which TI products or services are used. Information published by TI regarding third-party products or services does not constitute a license from TI to use such products or services or a warranty or endorsement thereof. Use of such information may require a license from a third party under the patents or other intellectual property of the third party, or a license from TI under the patents or other intellectual property of TI.

Reproduction of TI information in TI data books or data sheets is permissible only if reproduction is without alteration and is accompanied by all associated warranties, conditions, limitations, and notices. Reproduction of this information with alteration is an unfair and deceptive business practice. TI is not responsible or liable for such altered documentation. Information of third parties may be subject to additional restrictions.

Resale of TI products or services with statements different from or beyond the parameters stated by TI for that product or service voids all express and any implied warranties for the associated TI product or service and is an unfair and deceptive business practice. TI is not responsible or liable for any such statements.

TI products are not authorized for use in safety-critical applications (such as life support) where a failure of the TI product would reasonably be expected to cause severe personal injury or death, unless officers of the parties have executed an agreement specifically governing such use. Buyers represent that they have all necessary expertise in the safety and regulatory ramifications of their applications, and acknowledge and agree that they are solely responsible for all legal, regulatory and safety-related requirements concerning their products and any use of TI products in such safety-critical applications, notwithstanding any applications-related information or support that may be provided by TI. Further, Buyers must fully indemnify TI and its representatives against any damages arising out of the use of TI products in such safety-critical applications.

TI products are neither designed nor intended for use in military/aerospace applications or environments unless the TI products are specifically designated by TI as military-grade or "enhanced plastic." Only products designated by TI as military-grade meet military specifications. Buyers acknowledge and agree that any such use of TI products which TI has not designated as military-grade is solely at the Buyer's risk, and that they are solely responsible for compliance with all legal and regulatory requirements in connection with such use.

TI products are neither designed nor intended for use in automotive applications or environments unless the specific TI products are designated by TI as compliant with ISO/TS 16949 requirements. Buyers acknowledge and agree that, if they use any non-designated products in automotive applications, TI will not be responsible for any failure to meet such requirements.

Following are URLs where you can obtain information on other Texas Instruments products and application solutions:

Products

Audio	www.ti.com/audio
Amplifiers	amplifier.ti.com
Data Converters	dataconverter.ti.com
DLP® Products	www.dlp.com
DSP	dsp.ti.com
Clocks and Timers	www.ti.com/clocks
Interface	interface.ti.com
Logic	logic.ti.com
Power Mgmt	power.ti.com
Microcontrollers	microcontroller.ti.com
RFID	www.ti-rfid.com
RF/IF and ZigBee® Solutions	www.ti.com/lprf

Applications

Communications and Telecom	www.ti.com/communications
Computers and Peripherals	www.ti.com/computers
Consumer Electronics	www.ti.com/consumer-apps
Energy and Lighting	www.ti.com/energy
Industrial	www.ti.com/industrial
Medical	www.ti.com/medical
Security	www.ti.com/security
Space, Avionics and Defense	www.ti.com/space-avionics-defense
Transportation and Automotive	www.ti.com/automotive
Video and Imaging	www.ti.com/video
Wireless	www.ti.com/wireless-apps

TI E2E Community Home Page

e2e.ti.com

Mailing Address: Texas Instruments, Post Office Box 655303, Dallas, Texas 75265
Copyright © 2011, Texas Instruments Incorporated