

SN54F157A, SN74F157A

QUADRUPLE 2-LINE TO 1-LINE DATA SELECTORS/MULTIPLEXERS

SDFS053A – MARCH 1987 – REVISED OCTOBER 1993

- Buffered Inputs and Outputs
- Package Options Include Plastic Small-Outline Packages, Ceramic Chip Carriers, and Standard Plastic and Ceramic 300-mil DIPs

description

The 'F157A is a quadruple 2-input data selector/multiplexer featuring a common strobe (\overline{G}) input. When the strobe is high, all outputs are low. When the strobe is low, a 4-bit word is selected from one of two sources and is routed to the four outputs. The 'F157A provides true data.

The SN54F157A is characterized for operation over the full military temperature range of -55°C to 125°C . The SN74F157A is characterized for operation from 0°C to 70°C .

FUNCTION TABLE

INPUTS				OUTPUT Y
\overline{G}	$\overline{A/B}$	A	B	
H	X	X	X	L
L	L	L	X	L
L	L	H	X	H
L	H	X	L	L
L	H	X	H	H

SN54F157A . . . J PACKAGE
SN74F157A . . . D OR N PACKAGE
(TOP VIEW)

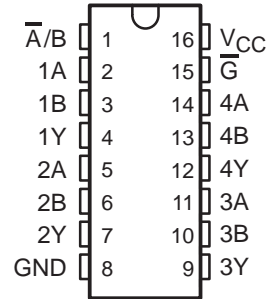

SN54F157A . . . FK PACKAGE
(TOP VIEW)

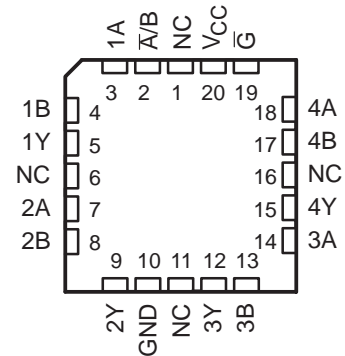

NC – No internal connection

SN54F157A, SN74F157A QUADRUPLE 2-LINE TO 1-LINE DATA SELECTORS/MULTIPLEXERS

SDFS053A – MARCH 1987 – REVISED OCTOBER 1993

logic symbol†

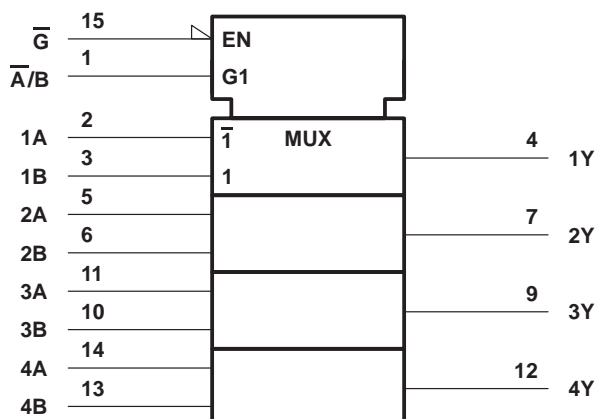

† This symbol is in accordance with ANSI/IEEE Std 91-1984 and IEC Publication 617-12.

Pin numbers shown are for the D, J, and N packages.

logic diagram (positive logic)

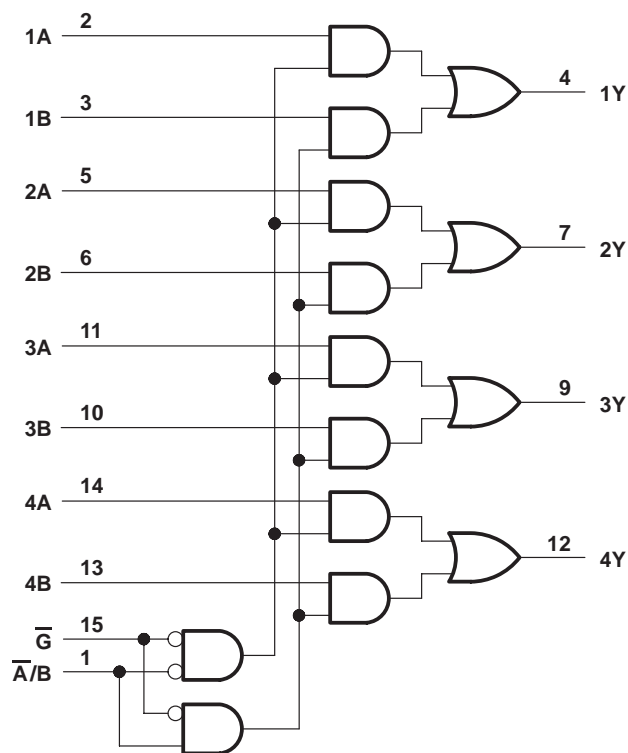

absolute maximum ratings over operating free-air temperature range (unless otherwise noted)‡

Supply voltage range, V_{CC}	-0.5 V to 7 V
Input voltage range (see Note 1)	-1.2 V to 7 V
Input current range	-30 mA to 5 mA
Voltage range applied to any output in the high state	-0.5 V to V_{CC}
Current into any output in the low state	40 mA
Operating free-air temperature range: SN54F157A	-55°C to 125°C
SN74F157A	0°C to 70°C
Storage temperature range	-65°C to 150°C

‡ Stresses beyond those listed under "absolute maximum ratings" may cause permanent damage to the device. These are stress ratings only and functional operation of the device at these or any other conditions beyond those indicated under "recommended operating conditions" is not implied. Exposure to absolute-maximum-rated conditions for extended periods may affect device reliability.

NOTE 1: The input voltage rating may be exceeded provided that the input current rating is observed.

recommended operating conditions

	SN54F157A			SN74F157A			UNIT
	MIN	NOM	MAX	MIN	NOM	MAX	
V_{CC} Supply voltage	4.5	5	5.5	4.5	5	5.5	V
V_{IH} High-level input voltage	2			2			V
V_{IL} Low-level input voltage			0.8			0.8	V
I_{IK} Input clamp current			-18			-18	mA
I_{OH} High-level output current			-1			-1	mA
I_{OL} Low-level output current			20			20	mA
T_A Operating free-air temperature	-55		125	0		70	°C



POST OFFICE BOX 655303 • DALLAS, TEXAS 75265

SN54F157A, SN74F157A

QUADRUPLE 2-LINE TO 1-LINE DATA SELECTORS/MULTIPLEXERS

SDFS053A – MARCH 1987 – REVISED OCTOBER 1993

electrical characteristics over recommended operating free-air temperature range (unless otherwise noted)

PARAMETER	TEST CONDITIONS	SN54F157A			SN74F157A			UNIT
		MIN	TYP†	MAX	MIN	TYP†	MAX	
V_{IK}	$V_{CC} = 4.5\text{ V}$, $I_I = -18\text{ mA}$			-1.2			-1.2	V
V_{OH}	$V_{CC} = 4.5\text{ V}$, $I_{OH} = -1\text{ mA}$	2.5	3.4		2.5	3.4		V
	$V_{CC} = 4.75\text{ V}$, $I_{OH} = -1\text{ mA}$				2.7			
V_{OL}	$V_{CC} = 4.5\text{ V}$, $I_{OL} = 20\text{ mA}$		0.3	0.5		0.3	0.5	V
I_I	$V_{CC} = 5.5\text{ V}$, $V_I = 7\text{ V}$			0.1			0.1	mA
I_{IH}	$V_{CC} = 5.5\text{ V}$, $V_I = 2.7\text{ V}$			20			20	μA
I_{IL}	$V_{CC} = 5.5\text{ V}$, $V_I = 0.5\text{ V}$			-0.6			-0.6	mA
I_{OS}^\ddagger	$V_{CC} = 5.5\text{ V}$, $V_O = 0$	-60		-150	-60		-150	mA
I_{CC}	$V_{CC} = 5.5\text{ V}$, $V_I = 4.5\text{ V}$		15	23		15.5	23	mA

† All typical values are at $V_{CC} = 5\text{ V}$, $T_A = 25^\circ\text{C}$.

‡ Not more than one output should be shorted at a time, and the duration of the short circuit should not exceed one second.

switching characteristics (see Note 2)

PARAMETER	FROM (INPUT)	TO (OUTPUT)	$V_{CC} = 5\text{ V}$, $C_L = 50\text{ pF}$, $R_L = 500\ \Omega$, $T_A = 25^\circ\text{C}$			$V_{CC} = 4.5\text{ V to }5.5\text{ V}$, $C_L = 50\text{ pF}$, $R_L = 500\ \Omega$, $T_A = \text{MIN to MAX}^\S$				UNIT
			'F157A			SN54F157A		SN74F157A		
			MIN	TYP	MAX	MIN	MAX	MIN	MAX	
t_{PLH}	$\overline{A/B}$	Y	3.2	6.6	10	3.2	12	3.2	11	ns
t_{PHL}			2.2	4.6	7	2.2	9	2.2	8	
t_{PLH}	\overline{G}	Y	4.2	6.6	9.5	4.2	13	4.2	11	ns
t_{PHL}			1.7	4.1	6.5	1.7	7.5	1.7	7	
t_{PLH}	A or B	Y	1.7	4.1	6	1.7	7.5	1.7	6.5	ns
t_{PHL}			1.7	3.6	5.5	1	7.5	1.2	7	

§ For conditions shown as MIN or MAX, use the appropriate value specified under recommended operating conditions.

NOTE 2: Load circuits and voltage waveforms are shown in Section 1.

IMPORTANT NOTICE

Texas Instruments and its subsidiaries (TI) reserve the right to make changes to their products or to discontinue any product or service without notice, and advise customers to obtain the latest version of relevant information to verify, before placing orders, that information being relied on is current and complete. All products are sold subject to the terms and conditions of sale supplied at the time of order acknowledgement, including those pertaining to warranty, patent infringement, and limitation of liability.

TI warrants performance of its semiconductor products to the specifications applicable at the time of sale in accordance with TI's standard warranty. Testing and other quality control techniques are utilized to the extent TI deems necessary to support this warranty. Specific testing of all parameters of each device is not necessarily performed, except those mandated by government requirements.

CERTAIN APPLICATIONS USING SEMICONDUCTOR PRODUCTS MAY INVOLVE POTENTIAL RISKS OF DEATH, PERSONAL INJURY, OR SEVERE PROPERTY OR ENVIRONMENTAL DAMAGE ("CRITICAL APPLICATIONS"). TI SEMICONDUCTOR PRODUCTS ARE NOT DESIGNED, AUTHORIZED, OR WARRANTED TO BE SUITABLE FOR USE IN LIFE-SUPPORT DEVICES OR SYSTEMS OR OTHER CRITICAL APPLICATIONS. INCLUSION OF TI PRODUCTS IN SUCH APPLICATIONS IS UNDERSTOOD TO BE FULLY AT THE CUSTOMER'S RISK.

In order to minimize risks associated with the customer's applications, adequate design and operating safeguards must be provided by the customer to minimize inherent or procedural hazards.

TI assumes no liability for applications assistance or customer product design. TI does not warrant or represent that any license, either express or implied, is granted under any patent right, copyright, mask work right, or other intellectual property right of TI covering or relating to any combination, machine, or process in which such semiconductor products or services might be or are used. TI's publication of information regarding any third party's products or services does not constitute TI's approval, warranty or endorsement thereof.