

SN74CBTD3384C

10-BIT FET BUS SWITCH WITH LEVEL SHIFTING 5-V BUS SWITCH WITH -2 -V UNDERSHOOT PROTECTION

SCDS133A – SEPTEMBER 2003 – REVISED OCTOBER 2003

- Undershoot Protection for Off-Isolation on A and B Ports Up To -2 V
- Integrated Diode to V_{CC} Provides 5-V Input Down To 3.3-V Output Level Shift
- Bidirectional Data Flow, With Near-Zero Propagation Delay
- Low ON-State Resistance (r_{on}) Characteristics ($r_{on} = 3 \Omega$ Typical)
- Low Input/Output Capacitance Minimizes Loading and Signal Distortion ($C_{iO(OFF)} = 5$ pF Typical)
- Data and Control Inputs Provide Undershoot Clamp Diodes
- V_{CC} Operating Range From 4.5 V to 5.5 V
- Data I/Os Support 0 to 5-V Signaling Levels (0.8-V, 1.2-V, 1.5-V, 1.8-V, 2.5-V, 3.3-V, 5-V)
- Control Inputs Can be Driven by TTL or 5-V/3.3-V CMOS Outputs
- I_{off} Supports Partial-Power-Down Mode Operation
- Latch-Up Performance Exceeds 100 mA Per JESD 78, Class II
- ESD Performance Tested Per JESD 22
 - 2000-V Human-Body Model (A114-B, Class II)
 - 1000-V Charged-Device Model (C101)
- Supports Both Digital and Analog Applications: Memory Interleaving, Bus Isolation, Low-Distortion Signal Gating

DB, DBQ, DGV, DW, OR PW PACKAGE
(TOP VIEW)

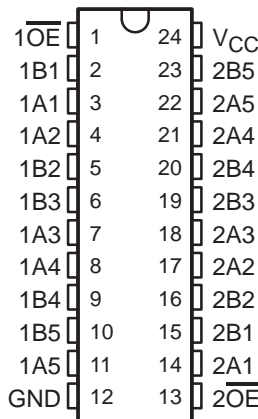

description/ordering information

ORDERING INFORMATION

T _A	PACKAGE†	ORDERABLE PART NUMBER	TOP-SIDE MARKING	
-40°C to 85°C	SOIC – DW	Tube	SN74CBTD3384CDW	
		Tape and reel	SN74CBTD3384CDWR	
	SSOP – DB	Tube	SN74CBTD3384CDB	
		Tape and reel	SN74CBTD3384CDBR	
	SSOP (QSOP) – DBQ	Tape and reel	SN74CBTD3384CDBQR	CBTD3384C
	TSSOP – PW	Tube	SN74CBTD3384CPW	CC384C
Tape and reel		SN74CBTD3384CPWR		
TVSOP – DGV	Tape and reel	SN74CBTD3384CDGVR	CC384C	

† Package drawings, standard packing quantities, thermal data, symbolization, and PCB design guidelines are available at www.ti.com/sc/package.



Please be aware that an important notice concerning availability, standard warranty, and use in critical applications of Texas Instruments semiconductor products and disclaimers thereto appears at the end of this data sheet.

PRODUCTION DATA information is current as of publication date. Products conform to specifications per the terms of Texas Instruments standard warranty. Production processing does not necessarily include testing of all parameters.



POST OFFICE BOX 655303 • DALLAS, TEXAS 75265

Copyright © 2003, Texas Instruments Incorporated

SN74CBTD3384C
10-BIT FET BUS SWITCH WITH LEVEL SHIFTING
5-V BUS SWITCH WITH -2-V UNDERSHOOT PROTECTION

SCDS133A – SEPTEMBER 2003 – REVISED OCTOBER 2003

description/ordering information (continued)

The SN74CBTD3384C is a high-speed TTL-compatible FET bus switch with low ON-state resistance (r_{on}), allowing for minimal propagation delay. This device features an integrated diode in series with V_{CC} to provide level shifting for 5-V input down to 3.3-V output levels. Active Undershoot-Protection Circuitry on the A and B ports of the SN74CBTD3384C provides protection for undershoot up to -2 V by sensing an undershoot event and ensuring that the switch remains in the proper OFF state.

The SN74CBTD3384C is organized as two 5-bit bus switches with separate output-enable ($1\overline{OE}$, $2\overline{OE}$) inputs. It can be used as two 5-bit bus switches or as one 10-bit bus switch. When \overline{OE} is low, the associated 5-bit bus switch is ON, and the A port is connected to the B port, allowing bidirectional data flow between ports. When \overline{OE} is high, the associated 5-bit bus switch is OFF, and a high-impedance state exists between the A and B ports.

This device is fully specified for partial-power-down applications using I_{off} . The I_{off} feature ensures that damaging current will not backflow through the device when it is powered down. The device has isolation during power off.

To ensure the high-impedance state during power up or power down, \overline{OE} should be tied to V_{CC} through a pullup resistor; the minimum value of the resistor is determined by the current-sinking capability of the driver.

FUNCTION TABLE
(each 5-bit bus switch)

INPUT \overline{OE}	INPUT/OUTPUT A	FUNCTION
L	B	A port = B port
H	Z	Disconnect

logic diagram (positive logic)

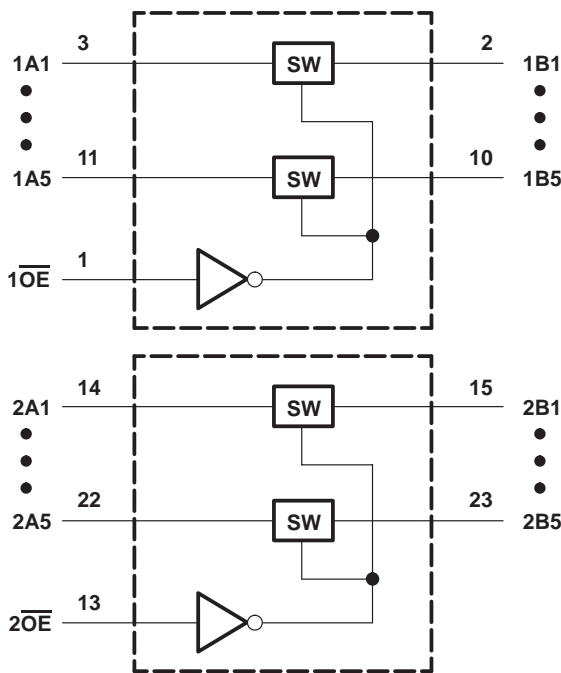

SN74CBTD3384C
10-BIT FET BUS SWITCH WITH LEVEL SHIFTING
5-V BUS SWITCH WITH -2-V UNDERSHOOT PROTECTION

SCDS133A – SEPTEMBER 2003 – REVISED OCTOBER 2003

simplified schematic, each FET switch (SW)

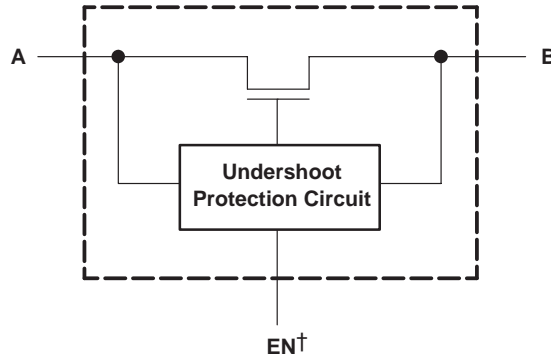

† EN is the internal enable signal applied to the switch.

absolute maximum ratings over operating free-air temperature range (unless otherwise noted)‡

Supply voltage range, V_{CC}	-0.5 V to 7 V
Control input voltage range, V_{IN} (see Notes 1 and 2)	-0.5 V to 7 V
Switch I/O voltage range, $V_{I/O}$ (see Notes 1, 2, and 3)	-0.5 V to 7 V
Control input clamp current, I_{IK} ($V_{IN} < 0$)	-50 mA
I/O port clamp current, $I_{I/OK}$ ($V_{I/O} < 0$)	-50 mA
ON-state switch current, $I_{I/O}$ (see Note 4)	± 128 mA
Continuous current through V_{CC} or GND terminals	± 100 mA
Package thermal impedance, θ_{JA} (see Note 5): DB package	63°C/W
DBQ package	61°C/W
DGV package	86°C/W
DW package	46°C/W
PW package	88°C/W
Storage temperature range, T_{stg}	-65°C to 150°C

‡ Stresses beyond those listed under “absolute maximum ratings” may cause permanent damage to the device. These are stress ratings only, and functional operation of the device at these or any other conditions beyond those indicated under “recommended operating conditions” is not implied. Exposure to absolute-maximum-rated conditions for extended periods may affect device reliability.

- NOTES: 1. All voltages are with respect to ground unless otherwise specified.
 2. The input and output voltage ratings may be exceeded if the input and output clamp-current ratings are observed.
 3. V_I and V_O are used to denote specific conditions for $V_{I/O}$.
 4. I_I and I_O are used to denote specific conditions for $I_{I/O}$.
 5. The package thermal impedance is calculated in accordance with JESD 51-7.

recommended operating conditions (see Notes 6 and 7)

	MIN	MAX	UNIT
V_{CC} Supply voltage	4.5	5.5	V
V_{IH} High-level control input voltage	2	5.5	V
V_{IL} Low-level control input voltage	0	0.8	V
$V_{I/O}$ Data input/output voltage	0	5.5	V
T_A Operating free-air temperature	-40	85	°C

- NOTES: 6. All unused control inputs of the device must be held at V_{CC} or GND to ensure proper device operation. Refer to the TI application report, *Implications of Slow or Floating CMOS Inputs*, literature number SCBA004.
 7. In applications with fast edge rates, multiple outputs switching, and operating at high frequencies, the output may have little or no level-shifting effect.



SN74CBTD3384C

10-BIT FET BUS SWITCH WITH LEVEL SHIFTING

5-V BUS SWITCH WITH -2-V UNDERSHOOT PROTECTION

SCDS133A – SEPTEMBER 2003 – REVISED OCTOBER 2003

electrical characteristics over recommended operating free-air temperature range (unless otherwise noted)

PARAMETER		TEST CONDITIONS		MIN	TYP†	MAX	UNIT
V _{IK}	Control inputs	V _{CC} = 4.5 V,	I _{IN} = -18 mA			-1.8	V
V _{IKU}	Data inputs	V _{CC} = 5 V,	0 mA > I _I ≥ -50 mA, V _{IN} = V _{CC} or GND, Switch OFF			-2	V
V _{OH}		See Figures 4 and 5					
I _{IN}	Control inputs	V _{CC} = 5.5 V,	V _{IN} = V _{CC} or GND			±1	μA
I _{OZ} ‡		V _{CC} = 5.5 V,	V _O = 0 to 5.5 V, V _I = 0, Switch OFF, V _{IN} = V _{CC} or GND			±10	μA
I _{off}		V _{CC} = 0,	V _O = 0 to 5.5 V, V _I = 0			10	μA
I _{CC}		V _{CC} = 5.5 V,	I _{I/O} = 0, V _{IN} = V _{CC} or GND, Switch ON or OFF			1.5	mA
ΔI _{CC} §	Control inputs	V _{CC} = 5.5 V,	One input at 3.4 V, Other inputs at V _{CC} or GND			2.5	mA
C _{in}	Control inputs	V _{IN} = 3 V or 0				3.5	pF
C _{io(OFF)}		V _{I/O} = 3 V or 0,	Switch OFF, V _{IN} = V _{CC} or GND			5	pF
C _{io(ON)}		V _{I/O} = 3 V or 0,	Switch ON, V _{IN} = V _{CC} or GND			12.5	pF
r _{on} ¶		V _{CC} = 4.5 V	V _I = 0	I _O = 64 mA	3	6	Ω
				I _O = 30 mA	3	6	
			V _I = 2.4 V,	I _O = -15 mA	8	20	

V_{IN} and I_{IN} refer to control inputs. V_I, V_O, I_I, and I_O refer to data pins.

† All typical values are at V_{CC} = 5 V (unless otherwise noted), T_A = 25°C.

‡ For I/O ports, the parameter I_{OZ} includes the input leakage current.

§ This is the increase in supply current for each input that is at the specified voltage level, rather than V_{CC} or GND.

¶ Measured by the voltage drop between the A and B terminals at the indicated current through the switch. ON-state resistance is determined by the lower of the voltages of the two (A or B) terminals.

switching characteristics over recommended operating free-air temperature range (unless otherwise noted) (see Figure 3)

PARAMETER	FROM (INPUT)	TO (OUTPUT)	V _{CC} = 5 V ± 0.5 V		UNIT
			MIN	MAX	
t _{pd} #	A or B	B or A	0.15		ns
t _{en}	$\overline{\text{OE}}$	A or B	1.5	4.8	ns
t _{dis}	$\overline{\text{OE}}$	A or B	1.5	4.8	ns

The propagation delay is the calculated RC time constant of the typical ON-state resistance of the switch and the specified load capacitance, when driven by an ideal voltage source (zero output impedance).

SN74CBTD3384C
10-BIT FET BUS SWITCH WITH LEVEL SHIFTING
5-V BUS SWITCH WITH -2-V UNDERSHOOT PROTECTION

SCDS133A – SEPTEMBER 2003 – REVISED OCTOBER 2003

undershoot characteristics (see Figures 1 and 2)

PARAMETER	TEST CONDITIONS	MIN	TYP†	MAX	UNIT
V_{OUTU}	$V_{CC} = 5.5\text{ V}$, Switch OFF, $V_{IN} = V_{CC}$ or GND	2	$V_{OH} - 0.3$		V

† All typical values are at $V_{CC} = 5\text{ V}$ (unless otherwise noted), $T_A = 25^\circ\text{C}$.

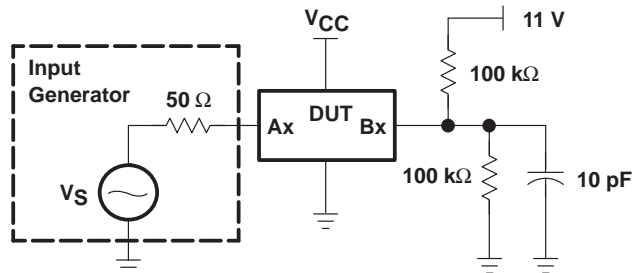

Figure 1. Device Test Setup

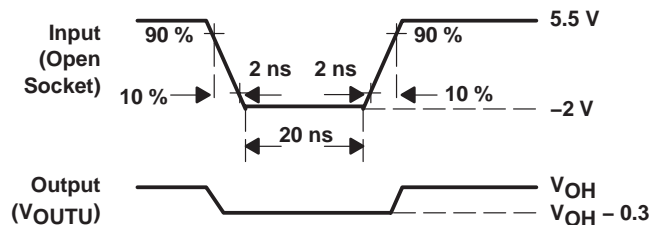
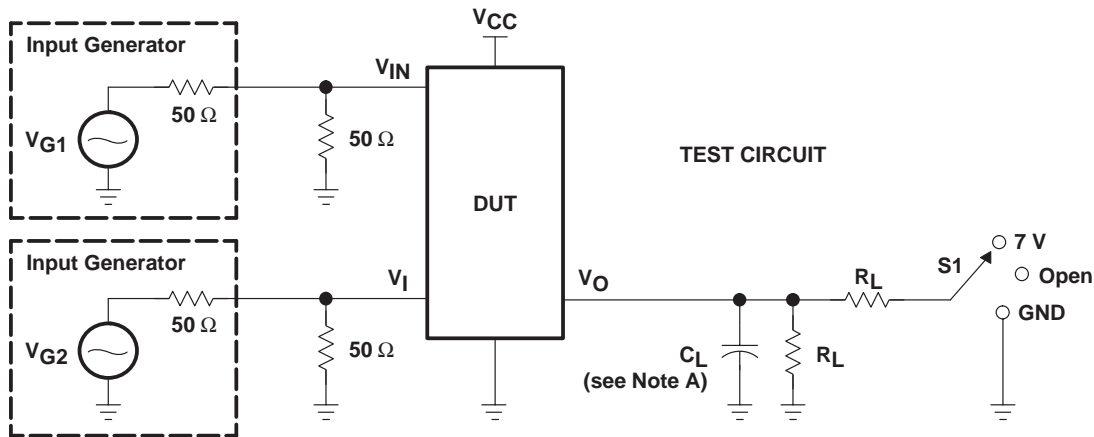

Figure 2. Transient Input Voltage (V_i) and Output Voltage (V_{OUTU}) Waveforms (Switch OFF)

SN74CBTD3384C
10-BIT FET BUS SWITCH WITH LEVEL SHIFTING
5-V BUS SWITCH WITH -2-V UNDERSHOOT PROTECTION

SCDS133A – SEPTEMBER 2003 – REVISED OCTOBER 2003

**PARAMETER MEASUREMENT INFORMATION
 FOR LEVEL SHIFTER**



TEST	VCC	S1	RL	VI	CL	VΔ
t _{pd} (s)	5 V ± 0.5 V	Open	500 Ω	VCC or GND	50 pF	
t _{PLZ} /t _{PZL}	5 V ± 0.5 V	7 V	500 Ω	GND	50 pF	0.3 V
t _{PHZ} /t _{PZH}	5 V ± 0.5 V	Open	500 Ω	VCC	50 pF	0.3 V

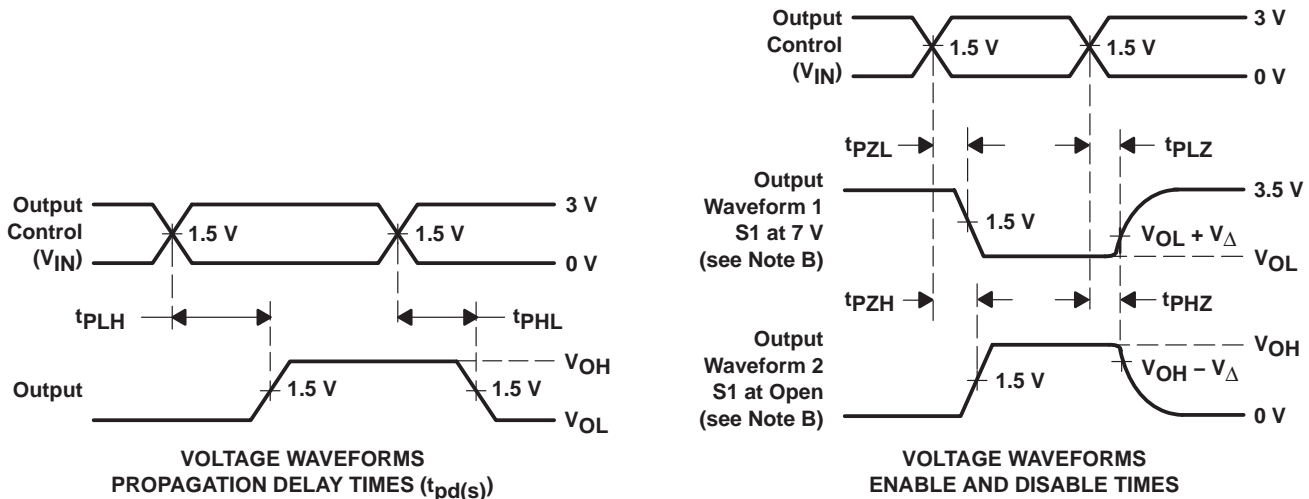

- NOTES:
- A. C_L includes probe and jig capacitance.
 - B. Waveform 1 is for an output with internal conditions such that the output is low except when disabled by the output control. Waveform 2 is for an output with internal conditions such that the output is high except when disabled by the output control.
 - C. All input pulses are supplied by generators having the following characteristics: PRR ≤ 10 MHz, Z_O = 50 Ω, t_r ≤ 2.5 ns, t_f ≤ 2.5 ns.
 - D. The outputs are measured one at a time with one transition per measurement.
 - E. t_{PLZ} and t_{PHZ} are the same as t_{dis}.
 - F. t_{PZL} and t_{PZH} are the same as t_{en}.
 - G. t_{PLH} and t_{PHL} are the same as t_{pd}(s). The t_{pd} propagation delay is the calculated RC time constant of the typical ON-state resistance of the switch and the specified load capacitance, when driven by an ideal voltage source (zero output impedance).
 - H. All parameters and waveforms are not applicable to all devices.

Figure 3. Test Circuit and Voltage Waveforms

SN74CBTD3384C
10-BIT FET BUS SWITCH WITH LEVEL SHIFTING
5-V BUS SWITCH WITH -2-V UNDERSHOOT PROTECTION

SCDS133A - SEPTEMBER 2003 - REVISED OCTOBER 2003

TYPICAL CHARACTERISTICS

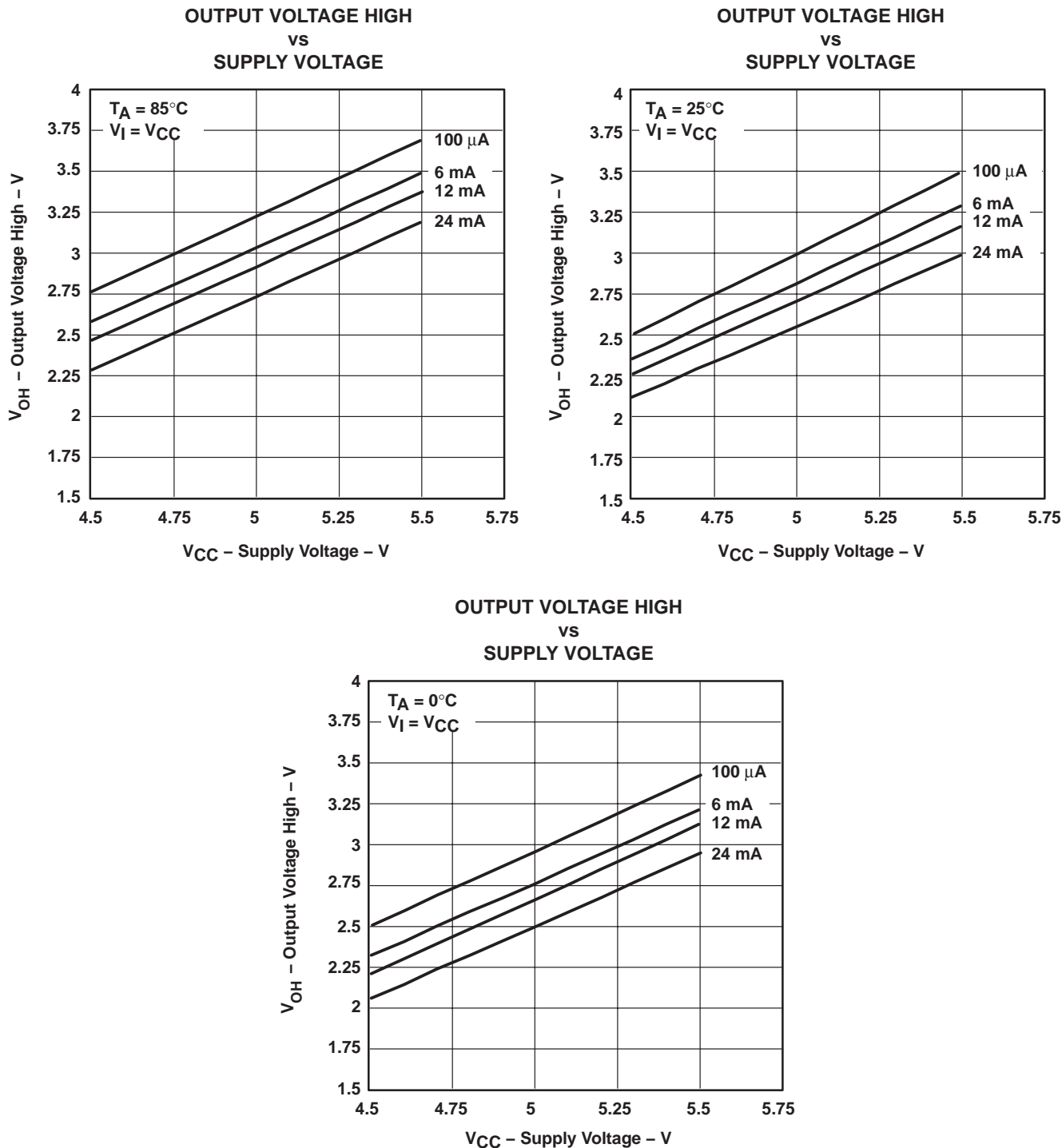

TYPICAL CHARACTERISTICS (continued)

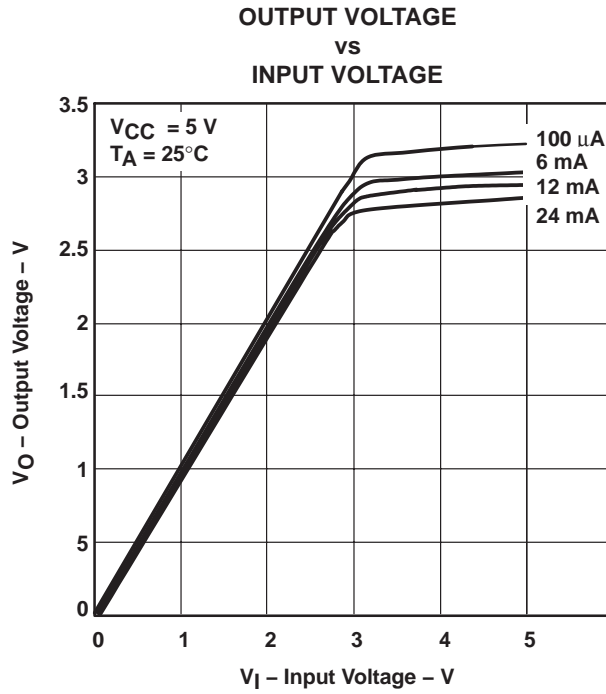

Figure 5. Data Output Voltage vs Data Input Voltage

PACKAGING INFORMATION

Orderable Device	Status ⁽¹⁾	Package Type	Package Drawing	Pins	Package Qty	Eco Plan ⁽²⁾	Lead/Ball Finish	MSL Peak Temp ⁽³⁾
74CBTD3384CDBQRE4	ACTIVE	SSOP/QSOP	DBQ	24	2500	Green (RoHS & no Sb/Br)	CU NIPDAU	Level-2-260C-1 YEAR
74CBTD3384CDBQRG4	ACTIVE	SSOP/QSOP	DBQ	24	2500	Green (RoHS & no Sb/Br)	CU NIPDAU	Level-2-260C-1 YEAR
74CBTD3384CDGVRE4	ACTIVE	TVSOP	DGV	24	2000	Green (RoHS & no Sb/Br)	CU NIPDAU	Level-1-260C-UNLIM
74CBTD3384CDGVRG4	ACTIVE	TVSOP	DGV	24	2000	Green (RoHS & no Sb/Br)	CU NIPDAU	Level-1-260C-UNLIM
SN74CBTD3384CDBQR	ACTIVE	SSOP/QSOP	DBQ	24	2500	Green (RoHS & no Sb/Br)	CU NIPDAU	Level-2-260C-1 YEAR
SN74CBTD3384CDBR	ACTIVE	SSOP	DB	24	2000	Green (RoHS & no Sb/Br)	CU NIPDAU	Level-1-260C-UNLIM
SN74CBTD3384CDBRE4	ACTIVE	SSOP	DB	24	2000	Green (RoHS & no Sb/Br)	CU NIPDAU	Level-1-260C-UNLIM
SN74CBTD3384CDBRG4	ACTIVE	SSOP	DB	24	2000	Green (RoHS & no Sb/Br)	CU NIPDAU	Level-1-260C-UNLIM
SN74CBTD3384CDGVR	ACTIVE	TVSOP	DGV	24	2000	Green (RoHS & no Sb/Br)	CU NIPDAU	Level-1-260C-UNLIM
SN74CBTD3384CDW	ACTIVE	SOIC	DW	24	25	Green (RoHS & no Sb/Br)	CU NIPDAU	Level-1-260C-UNLIM
SN74CBTD3384CDWE4	ACTIVE	SOIC	DW	24	25	Green (RoHS & no Sb/Br)	CU NIPDAU	Level-1-260C-UNLIM
SN74CBTD3384CDWG4	ACTIVE	SOIC	DW	24	25	Green (RoHS & no Sb/Br)	CU NIPDAU	Level-1-260C-UNLIM
SN74CBTD3384CDWR	ACTIVE	SOIC	DW	24	2000	Green (RoHS & no Sb/Br)	CU NIPDAU	Level-1-260C-UNLIM
SN74CBTD3384CDWRE4	ACTIVE	SOIC	DW	24	2000	Green (RoHS & no Sb/Br)	CU NIPDAU	Level-1-260C-UNLIM
SN74CBTD3384CDWRG4	ACTIVE	SOIC	DW	24	2000	Green (RoHS & no Sb/Br)	CU NIPDAU	Level-1-260C-UNLIM
SN74CBTD3384CPW	ACTIVE	TSSOP	PW	24	60	Green (RoHS & no Sb/Br)	CU NIPDAU	Level-1-260C-UNLIM
SN74CBTD3384CPWE4	ACTIVE	TSSOP	PW	24	60	Green (RoHS & no Sb/Br)	CU NIPDAU	Level-1-260C-UNLIM
SN74CBTD3384CPWG4	ACTIVE	TSSOP	PW	24	60	Green (RoHS & no Sb/Br)	CU NIPDAU	Level-1-260C-UNLIM
SN74CBTD3384CPWR	ACTIVE	TSSOP	PW	24	2000	Green (RoHS & no Sb/Br)	CU NIPDAU	Level-1-260C-UNLIM
SN74CBTD3384CPWRE4	ACTIVE	TSSOP	PW	24	2000	Green (RoHS & no Sb/Br)	CU NIPDAU	Level-1-260C-UNLIM
SN74CBTD3384CPWRG4	ACTIVE	TSSOP	PW	24	2000	Green (RoHS & no Sb/Br)	CU NIPDAU	Level-1-260C-UNLIM

⁽¹⁾ The marketing status values are defined as follows:

ACTIVE: Product device recommended for new designs.

LIFEBUY: TI has announced that the device will be discontinued, and a lifetime-buy period is in effect.

NRND: Not recommended for new designs. Device is in production to support existing customers, but TI does not recommend using this part in a new design.

PREVIEW: Device has been announced but is not in production. Samples may or may not be available.

OBSOLETE: TI has discontinued the production of the device.

(2) Eco Plan - The planned eco-friendly classification: Pb-Free (RoHS), Pb-Free (RoHS Exempt), or Green (RoHS & no Sb/Br) - please check <http://www.ti.com/productcontent> for the latest availability information and additional product content details.

TBD: The Pb-Free/Green conversion plan has not been defined.

Pb-Free (RoHS): TI's terms "Lead-Free" or "Pb-Free" mean semiconductor products that are compatible with the current RoHS requirements for all 6 substances, including the requirement that lead not exceed 0.1% by weight in homogeneous materials. Where designed to be soldered at high temperatures, TI Pb-Free products are suitable for use in specified lead-free processes.

Pb-Free (RoHS Exempt): This component has a RoHS exemption for either 1) lead-based flip-chip solder bumps used between the die and package, or 2) lead-based die adhesive used between the die and leadframe. The component is otherwise considered Pb-Free (RoHS compatible) as defined above.

Green (RoHS & no Sb/Br): TI defines "Green" to mean Pb-Free (RoHS compatible), and free of Bromine (Br) and Antimony (Sb) based flame retardants (Br or Sb do not exceed 0.1% by weight in homogeneous material)

(3) MSL, Peak Temp. -- The Moisture Sensitivity Level rating according to the JEDEC industry standard classifications, and peak solder temperature.

Important Information and Disclaimer:The information provided on this page represents TI's knowledge and belief as of the date that it is provided. TI bases its knowledge and belief on information provided by third parties, and makes no representation or warranty as to the accuracy of such information. Efforts are underway to better integrate information from third parties. TI has taken and continues to take reasonable steps to provide representative and accurate information but may not have conducted destructive testing or chemical analysis on incoming materials and chemicals. TI and TI suppliers consider certain information to be proprietary, and thus CAS numbers and other limited information may not be available for release.

In no event shall TI's liability arising out of such information exceed the total purchase price of the TI part(s) at issue in this document sold by TI to Customer on an annual basis.

TAPE AND REEL INFORMATION



QUADRANT ASSIGNMENTS FOR PIN 1 ORIENTATION IN TAPE

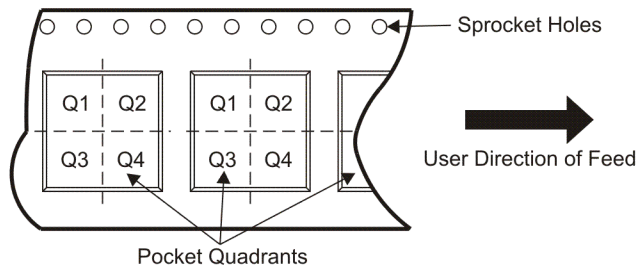

*All dimensions are nominal

Device	Package Type	Package Drawing	Pins	SPQ	Reel Diameter (mm)	Reel Width W1 (mm)	A0 (mm)	B0 (mm)	K0 (mm)	P1 (mm)	W (mm)	Pin1 Quadrant
SN74CBTD3384CDBQR	SSOP/QSOP	DBQ	24	2500	330.0	16.4	6.5	9.0	2.1	8.0	16.0	Q1
SN74CBTD3384CDBR	SSOP	DB	24	2000	330.0	16.4	8.2	8.8	2.5	12.0	16.0	Q1
SN74CBTD3384CDGVR	TVSOP	DGV	24	2000	330.0	12.4	7.0	5.6	1.6	8.0	12.0	Q1
SN74CBTD3384CDWR	SOIC	DW	24	2000	330.0	24.4	10.75	15.7	2.7	12.0	24.0	Q1
SN74CBTD3384CPWR	TSSOP	PW	24	2000	330.0	16.4	6.95	8.3	1.6	8.0	16.0	Q1

TAPE AND REEL BOX DIMENSIONS



*All dimensions are nominal

Device	Package Type	Package Drawing	Pins	SPQ	Length (mm)	Width (mm)	Height (mm)
SN74CBTD3384CDBQR	SSOP/QSOP	DBQ	24	2500	346.0	346.0	33.0
SN74CBTD3384CDBR	SSOP	DB	24	2000	346.0	346.0	33.0
SN74CBTD3384CDGVR	TVSOP	DGV	24	2000	346.0	346.0	29.0
SN74CBTD3384CDWR	SOIC	DW	24	2000	346.0	346.0	41.0
SN74CBTD3384CPWR	TSSOP	PW	24	2000	346.0	346.0	33.0

DB (R-PDSO-G**)

PLASTIC SMALL-OUTLINE

28 PINS SHOWN



- NOTES: A. All linear dimensions are in millimeters.
 B. This drawing is subject to change without notice.
 C. Body dimensions do not include mold flash or protrusion not to exceed 0,15.
 D. Falls within JEDEC MO-150

PW (R-PDSO-G**)

PLASTIC SMALL-OUTLINE PACKAGE

14 PINS SHOWN



4040064/F 01/97

- NOTES: A. All linear dimensions are in millimeters.
 B. This drawing is subject to change without notice.
 C. Body dimensions do not include mold flash or protrusion not to exceed 0,15.
 D. Falls within JEDEC MO-153

DGV (R-PDSO-G**)

PLASTIC SMALL-OUTLINE

24 PINS SHOWN



- NOTES: A. All linear dimensions are in millimeters.
 B. This drawing is subject to change without notice.
 C. Body dimensions do not include mold flash or protrusion, not to exceed 0,15 per side.
 D. Falls within JEDEC: 24/48 Pins – MO-153
 14/16/20/56 Pins – MO-194

DW (R-PDSO-G24)

PLASTIC SMALL-OUTLINE PACKAGE

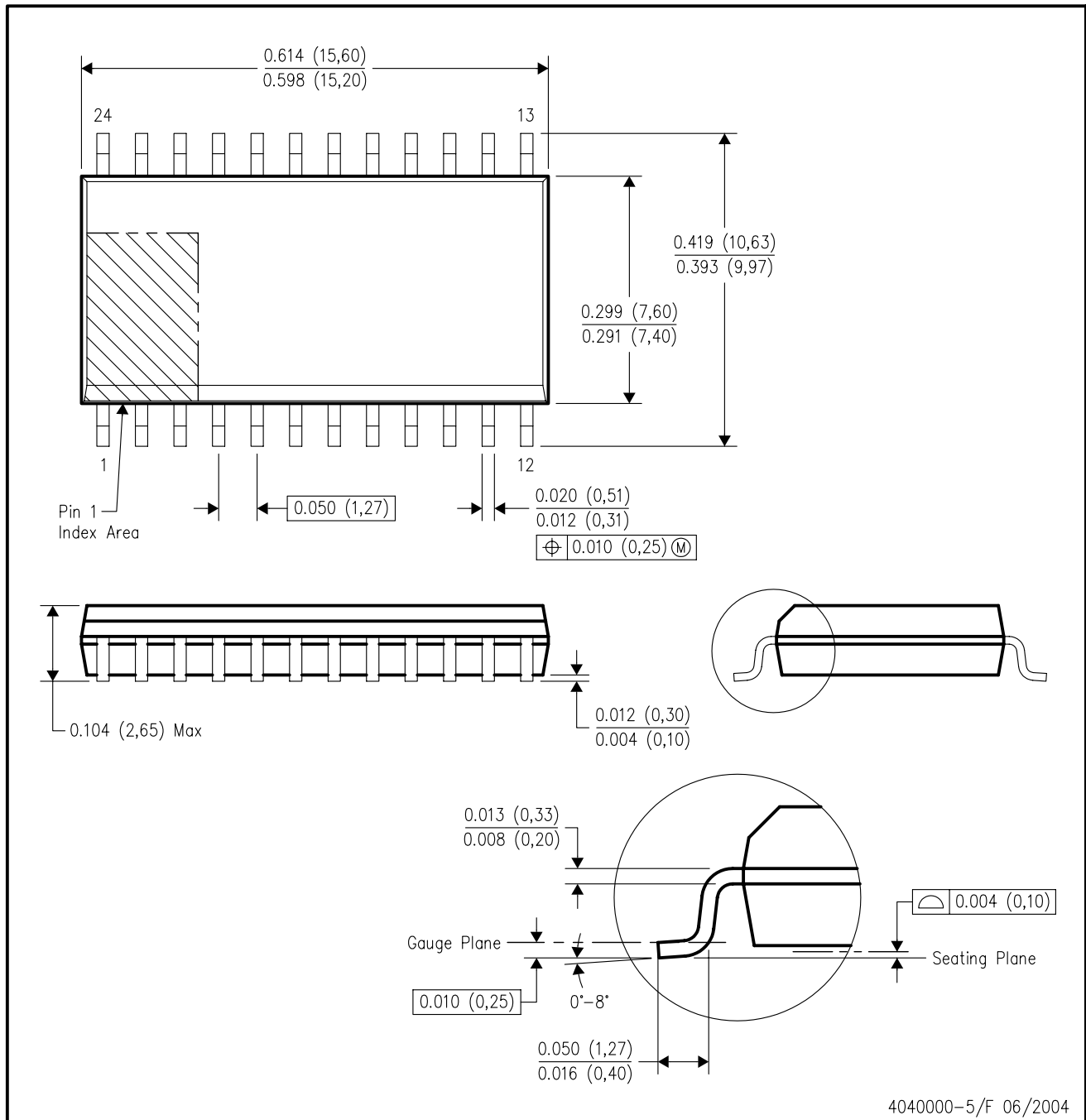

- NOTES:
- A. All linear dimensions are in inches (millimeters).
 - B. This drawing is subject to change without notice.
 - C. Body dimensions do not include mold flash or protrusion not to exceed 0.006 (0,15).
 - D. Falls within JEDEC MS-013 variation AD.

IMPORTANT NOTICE

Texas Instruments Incorporated and its subsidiaries (TI) reserve the right to make corrections, modifications, enhancements, improvements, and other changes to its products and services at any time and to discontinue any product or service without notice. Customers should obtain the latest relevant information before placing orders and should verify that such information is current and complete. All products are sold subject to TI's terms and conditions of sale supplied at the time of order acknowledgment.

TI warrants performance of its hardware products to the specifications applicable at the time of sale in accordance with TI's standard warranty. Testing and other quality control techniques are used to the extent TI deems necessary to support this warranty. Except where mandated by government requirements, testing of all parameters of each product is not necessarily performed.

TI assumes no liability for applications assistance or customer product design. Customers are responsible for their products and applications using TI components. To minimize the risks associated with customer products and applications, customers should provide adequate design and operating safeguards.

TI does not warrant or represent that any license, either express or implied, is granted under any TI patent right, copyright, mask work right, or other TI intellectual property right relating to any combination, machine, or process in which TI products or services are used. Information published by TI regarding third-party products or services does not constitute a license from TI to use such products or services or a warranty or endorsement thereof. Use of such information may require a license from a third party under the patents or other intellectual property of the third party, or a license from TI under the patents or other intellectual property of TI.

Reproduction of TI information in TI data books or data sheets is permissible only if reproduction is without alteration and is accompanied by all associated warranties, conditions, limitations, and notices. Reproduction of this information with alteration is an unfair and deceptive business practice. TI is not responsible or liable for such altered documentation. Information of third parties may be subject to additional restrictions.

Resale of TI products or services with statements different from or beyond the parameters stated by TI for that product or service voids all express and any implied warranties for the associated TI product or service and is an unfair and deceptive business practice. TI is not responsible or liable for any such statements.

TI products are not authorized for use in safety-critical applications (such as life support) where a failure of the TI product would reasonably be expected to cause severe personal injury or death, unless officers of the parties have executed an agreement specifically governing such use. Buyers represent that they have all necessary expertise in the safety and regulatory ramifications of their applications, and acknowledge and agree that they are solely responsible for all legal, regulatory and safety-related requirements concerning their products and any use of TI products in such safety-critical applications, notwithstanding any applications-related information or support that may be provided by TI. Further, Buyers must fully indemnify TI and its representatives against any damages arising out of the use of TI products in such safety-critical applications.

TI products are neither designed nor intended for use in military/aerospace applications or environments unless the TI products are specifically designated by TI as military-grade or "enhanced plastic." Only products designated by TI as military-grade meet military specifications. Buyers acknowledge and agree that any such use of TI products which TI has not designated as military-grade is solely at the Buyer's risk, and that they are solely responsible for compliance with all legal and regulatory requirements in connection with such use.

TI products are neither designed nor intended for use in automotive applications or environments unless the specific TI products are designated by TI as compliant with ISO/TS 16949 requirements. Buyers acknowledge and agree that, if they use any non-designated products in automotive applications, TI will not be responsible for any failure to meet such requirements.

Following are URLs where you can obtain information on other Texas Instruments products and application solutions:

Products

Amplifiers	amplifier.ti.com
Data Converters	dataconverter.ti.com
DSP	dsp.ti.com
Clocks and Timers	www.ti.com/clocks
Interface	interface.ti.com
Logic	logic.ti.com
Power Mgmt	power.ti.com
Microcontrollers	microcontroller.ti.com
RFID	www.ti-rfid.com
RF/IF and ZigBee® Solutions	www.ti.com/lprf

Applications

Audio	www.ti.com/audio
Automotive	www.ti.com/automotive
Broadband	www.ti.com/broadband
Digital Control	www.ti.com/digitalcontrol
Medical	www.ti.com/medical
Military	www.ti.com/military
Optical Networking	www.ti.com/opticalnetwork
Security	www.ti.com/security
Telephony	www.ti.com/telephony
Video & Imaging	www.ti.com/video
Wireless	www.ti.com/wireless

Mailing Address: Texas Instruments, Post Office Box 655303, Dallas, Texas 75265
Copyright © 2008, Texas Instruments Incorporated