

SN74CB3T16211

24-BIT FET BUS SWITCH

2.5-V/3.3-V LOW-VOLTAGE BUS SWITCH WITH 5-V-TOLERANT LEVEL SHIFTER

SCDS147B – OCTOBER 2003 – REVISED JANUARY 2005

- Member of the Texas Instruments Widebus™ Family
- Output Voltage Translation Tracks V_{CC}
- Supports Mixed-Mode Signal Operation On All Data I/O Ports
 - 5-V Input Down to 3.3-V Output Level Shift, With 3.3-V V_{CC}
 - 5-V/3.3-V Input Down to 2.5-V Output Level Shift, With 2.5-V V_{CC}
- 5-V-Tolerant I/Os, With Device Powered Up or Powered Down
- Bidirectional Data Flow, With Near-Zero Propagation Delay
- Low ON-State Resistance (r_{on}) Characteristics ($r_{on} = 5 \Omega$ Typical)
- Low Input/Output Capacitance Minimizes Loading ($C_{iO(OFF)} = 5 \text{ pF}$ Typical)
- Data and Control Inputs Provide Undershoot Clamp Diodes
- Low Power Consumption ($I_{CC} = 70 \mu\text{A}$ Max)
- V_{CC} Operating Range From 2.3 V to 3.6 V
- Data I/Os Support 0- to 5-V Signaling Levels (0.8 V, 1.2 V, 1.5 V, 1.8 V, 2.5 V, 3.3 V, 5 V)
- Control Inputs Can be Driven by TTL or 5-V/3.3-V CMOS Outputs
- I_{off} Supports Partial-Power-Down Mode Operation
- Latch-Up Performance Exceeds 250 mA Per JESD 17
- ESD Performance Tested Per JESD 22
 - 2000-V Human-Body Model (A114-B, Class II)
 - 1000-V Charged-Device Model (C101)
- Supports Digital Applications: Level Translation, PCI Interface, Bus Isolation
- Ideal for Low-Power Portable Equipment

DGG, DGV, OR DL PACKAGE
(TOP VIEW)

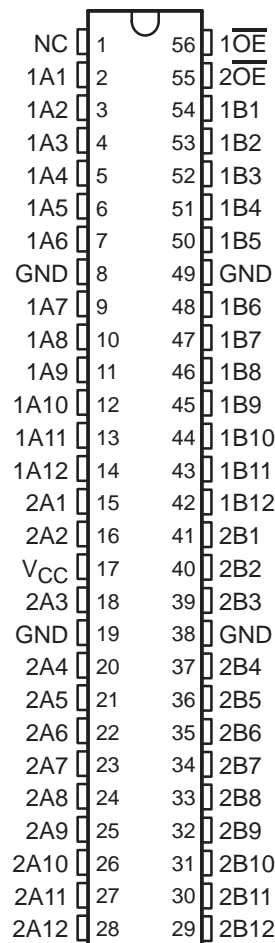

NC – No internal connection

description/ordering information

The SN74CB3T16211 is a high-speed TTL-compatible FET bus switch with low ON-state resistance (r_{on}), allowing for minimal propagation delay. The device fully supports mixed-mode signal operation on all data I/O ports by providing voltage translation that tracks V_{CC} . The SN74CB3T16211 supports systems using 5-V TTL, 3.3-V LVTTTL, and 2.5-V CMOS switching standards, as well as user-defined switching levels (see Figure 1).



Please be aware that an important notice concerning availability, standard warranty, and use in critical applications of Texas Instruments semiconductor products and disclaimers thereto appears at the end of this data sheet.

Widebus is a trademark of Texas Instruments.

PRODUCTION DATA information is current as of publication date. Products conform to specifications per the terms of Texas Instruments standard warranty. Production processing does not necessarily include testing of all parameters.



POST OFFICE BOX 655303 • DALLAS, TEXAS 75265

Copyright © 2005, Texas Instruments Incorporated

SN74CB3T16211
24-BIT FET BUS SWITCH
2.5-V/3.3-V LOW-VOLTAGE BUS SWITCH WITH 5-V-TOLERANT LEVEL SHIFTER

SCDS147B – OCTOBER 2003 – REVISED JANUARY 2005

description/ordering information (continued)

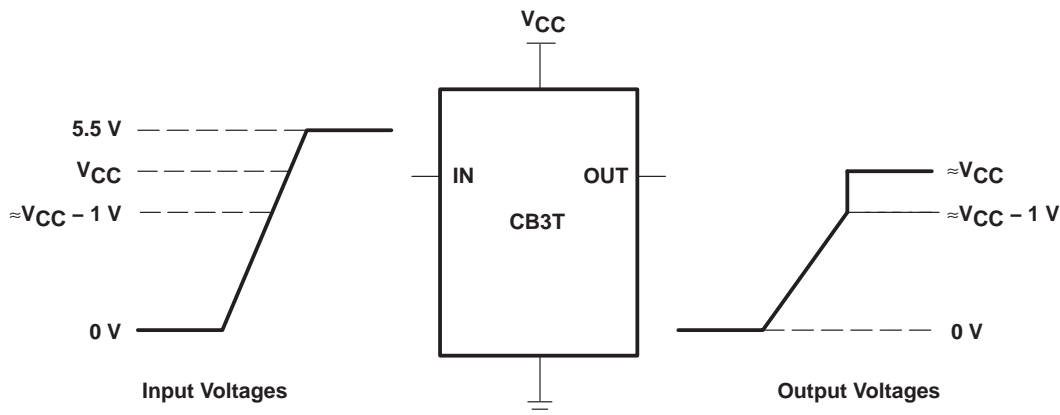

NOTE A: If the input high-voltage (V_{IH}) level is greater than or equal to $V_{CC} - 1\text{ V}$ and less than or equal to 5.5 V, the output high-voltage (V_{OH}) level is equal to approximately the V_{CC} voltage level.

Figure 1. Typical DC Voltage-Translation Characteristics

The I/O port of this device has a pullup current source that maintains the output voltage at V_{CC} when the device is ON and the input is greater than or equal to $V_{CC} - 1$. Because of the pullup current source, the output voltage level may be less than V_{CC} when the operating frequency is low and the I/O port is connected to a pulldown resistor. In order to maintain the output voltage at V_{CC} , a pullup resistor must be connected to V_{CC} , instead of a pulldown resistor to ground.

The SN74CB3T16211 is organized as two 12-bit bus switches with separate output-enable ($\overline{1OE}$, $\overline{2OE}$) inputs. It can be used as two 12-bit bus switches or as one 24-bit bus switch. When \overline{OE} is low, the associated 12-bit bus switch is ON, and the A port is connected to the B port, allowing bidirectional data flow between ports. When \overline{OE} is high, the associated 12-bit bus switch is OFF, and a high-impedance state exists between the A and B ports.

This device is fully specified for partial-power-down applications using I_{off} . The I_{off} feature ensures that damaging current will not backflow through the device when it is powered down. The device has isolation during power off.

To ensure the high-impedance state during power up or power down, \overline{OE} should be tied to V_{CC} through a pullup resistor; the minimum value of the resistor is determined by the current-sinking capability of the driver.

ORDERING INFORMATION

T_A	PACKAGE†		ORDERABLE PART NUMBER	TOP-SIDE MARKING
-40°C to 85°C	SSOP – DL	Tube	SN74CB3T16211DL	CB3T16211
		Tape and reel	SN74CB3T16211DLR	
	TSSOP – DGG	Tube	SN74CB3T16211DGG	CB3T16211
		Tape and reel	SN74CB3T16211DGGR	
	TVSOP – DGV	Tape and reel	SN74CB3T16211DGV	KR211
	VFBGA – ZQL (PB-Free)	Tape and reel	SN74CB3T16211ZQLR	KR211

† Package drawings, standard packing quantities, thermal data, symbolization, and PCB design guidelines are available at www.ti.com/sc/package.

SN74CB3T16211
24-BIT FET BUS SWITCH
2.5-V/3.3-V LOW-VOLTAGE BUS SWITCH WITH 5-V-TOLERANT LEVEL SHIFTER

SCDS147B – OCTOBER 2003 – REVISED JANUARY 2005

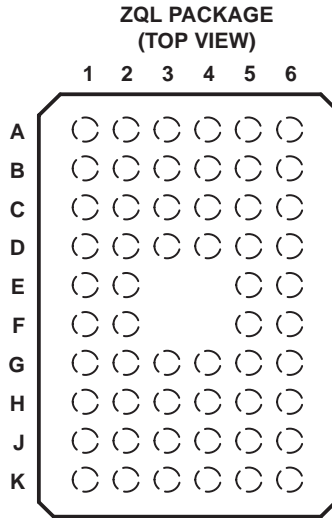

terminal assignments

	1	2	3	4	5	6
A	1A2	1A1	NC	$\overline{1OE}$	$\overline{2OE}$	1B1
B	1A5	1A4	1A3	1B2	1B3	1B4
C	1A7	GND	1A6	1B5	GND	1B6
D	1A10	1A8	1A9	1B8	1B7	1B9
E	1A12	1A11			1B10	1B11
F	2A1	2A2			2B1	1B12
G	V _{CC}	GND	2A3	2B3	GND	2B2
H	2A4	2A5	2A6	2B6	2B5	2B4
J	2A7	2A8	2A9	2B9	2B8	2B7
K	2A10	2A11	2A12	2B12	2B11	2B10

NC – No internal connection

**FUNCTION TABLE
(each 12-bit bus switch)**

INPUT \overline{OE}	INPUT/OUTPUT A	FUNCTION
L	B	A port = B port
H	Z	Disconnect

logic diagram (positive logic)

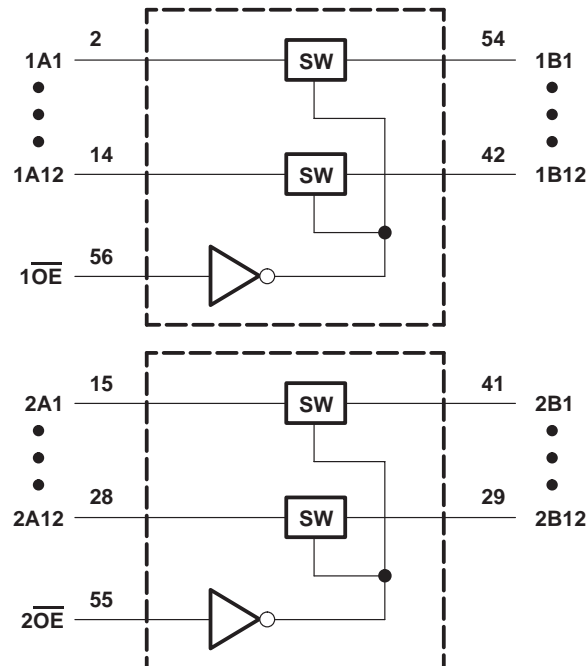

SN74CB3T16211
24-BIT FET BUS SWITCH
2.5-V/3.3-V LOW-VOLTAGE BUS SWITCH WITH 5-V-TOLERANT LEVEL SHIFTER

SCDS147B – OCTOBER 2003 – REVISED JANUARY 2005

simplified schematic, each FET switch (SW)

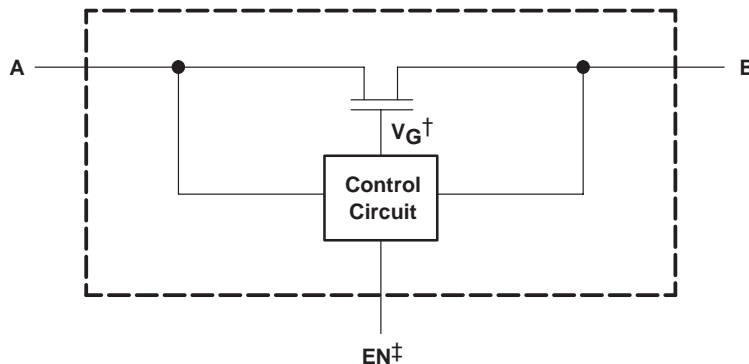

† Gate voltage (V_G) is equal to approximately $V_{CC} + V_T$ when the switch is ON and $V_I > V_{CC} + V_T$.
‡ Internal enable signal applied to the switch

absolute maximum ratings over operating free-air temperature range (unless otherwise noted)†

Supply voltage range, V_{CC} (see Note 1)	−0.5 V to 7 V
Control input voltage range, V_{IN} (see Notes 1 and 2)	−0.5 V to 7 V
Switch I/O voltage range, $V_{I/O}$ (see Notes 1, 2, and 3)	−0.5 V to 7 V
Control input clamp current, I_{IK} ($V_{IN} < 0$)	−50 mA
I/O port clamp current, $I_{I/OK}$ ($V_{I/O} < 0$)	−50 mA
ON-state switch current, $I_{I/O}$ (see Note 4)	±128 mA
Continuous current through V_{CC} or GND terminals	±100 mA
Package thermal impedance, θ_{JA} (see Note 5):	
DGG package	64°C/W
DGV package	48°C/W
DL package	56°C/W
ZQL package	42°C/W
Storage temperature range, T_{stg}	−65°C to 150°C

† Stresses beyond those listed under “absolute maximum ratings” may cause permanent damage to the device. These are stress ratings only, and functional operation of the device at these or any other conditions beyond those indicated under “recommended operating conditions” is not implied. Exposure to absolute-maximum-rated conditions for extended periods may affect device reliability.

- NOTES:
- All voltages are with respect to ground, unless otherwise specified.
 - The input and output voltage ratings may be exceeded if the input and output clamp-current ratings are observed.
 - V_I and V_O are used to denote specific conditions for $V_{I/O}$.
 - I_I and I_O are used to denote specific conditions for $I_{I/O}$.
 - The package thermal impedance is calculated in accordance with JESD 51-7.

recommended operating conditions (see Note 6)

		MIN	MAX	UNIT	
V_{CC}	Supply voltage	2.3	3.6	V	
V_{IH}	High-level control input voltage	$V_{CC} = 2.3\text{ V to }2.7\text{ V}$	1.7	5.5	V
		$V_{CC} = 2.7\text{ V to }3.6\text{ V}$	2	5.5	
V_{IL}	Low-level control input voltage	$V_{CC} = 2.3\text{ V to }2.7\text{ V}$	0	0.7	V
		$V_{CC} = 2.7\text{ V to }3.6\text{ V}$	0	0.8	
$V_{I/O}$	Data input/output voltage	0	5.5	V	
T_A	Operating free-air temperature	−40	85	°C	

NOTE 6: All unused control inputs of the device must be held at V_{CC} or GND to ensure proper device operation. Refer to the TI application report, *Implications of Slow or Floating CMOS Inputs*, literature number SCBA004.



2.5-V/3.3-V LOW-VOLTAGE BUS SWITCH WITH 5-V-TOLERANT LEVEL SHIFTER

SCDS147B – OCTOBER 2003 – REVISED JANUARY 2005

electrical characteristics over recommended operating free-air temperature range (unless otherwise noted)

PARAMETER		TEST CONDITIONS	MIN	TYP†	MAX	UNIT	
V_{IK}		$V_{CC} = 3\text{ V}$, $I_I = -18\text{ mA}$			-1.2	V	
V_{OH}		See Figures 3 and 4					
I_{IN}	Control inputs	$V_{CC} = 3.6\text{ V}$, $V_{IN} = 3.6\text{ V to } 5.5\text{ V or GND}$			± 10	μA	
I_I		$V_{CC} = 3.6\text{ V}$, Switch ON, $V_{IN} = V_{CC}$ or GND	$V_I = V_{CC} - 0.7\text{ V to } 5.5\text{ V}$		± 20	μA	
			$V_I = 0.7\text{ V to } V_{CC} - 0.7\text{ V}$		-40		
			$V_I = 0\text{ to } 0.7\text{ V}$		± 5		
I_{OZ}^\ddagger		$V_{CC} = 3.6\text{ V}$, $V_O = 0\text{ to } 5.5\text{ V}$, $V_I = 0$, Switch OFF, $V_{IN} = V_{CC}$ or GND			± 10	μA	
I_{off}		$V_{CC} = 0$, $V_O = 0\text{ to } 5.5\text{ V}$, $V_I = 0$			10	μA	
I_{CC}		$V_{CC} = 3.6\text{ V}$, $I_{I/O} = 0$, Switch ON or OFF, $V_{IN} = V_{CC}$ or GND	$V_I = V_{CC}$ or GND		70	μA	
			$V_I = 5.5\text{ V}$		70		
ΔI_{CC}^\S	Control inputs	$V_{CC} = 3\text{ V to } 3.6\text{ V}$, One input at $V_{CC} - 0.6\text{ V}$, Other inputs at V_{CC} or GND			300	μA	
C_{in}	Control inputs	$V_{CC} = 3.3\text{ V}$, $V_{IN} = V_{CC}$ or GND		4		pF	
$C_{io(OFF)}$		$V_{CC} = 3.3\text{ V}$, $V_{I/O} = 5.5\text{ V, } 3.3\text{ V, or GND}$, Switch OFF, $V_{IN} = V_{CC}$ or GND		5		pF	
$C_{io(ON)}$		$V_{CC} = 3.3\text{ V}$, Switch ON, $V_{IN} = V_{CC}$ or GND	$V_{I/O} = 5.5\text{ V or } 3.3\text{ V}$		5	pF	
			$V_{I/O} = \text{GND}$		13		
r_{on}^\parallel		$V_{CC} = 2.3\text{ V}$, TYP at $V_{CC} = 2.5\text{ V}$, $V_I = 0$	$I_O = 24\text{ mA}$		5	9.5	Ω
			$I_O = 16\text{ mA}$		5	9.5	
		$V_{CC} = 3\text{ V}$, $V_I = 0$	$I_O = 64\text{ mA}$		5	8.5	
			$I_O = 32\text{ mA}$		5	8.5	

V_{IN} and I_{IN} refer to control inputs. V_I , V_O , I_I , and I_O refer to data pins.

† All typical values are at $V_{CC} = 3.3\text{ V}$ (unless otherwise noted), $T_A = 25^\circ\text{C}$.

‡ For I/O ports, the parameter I_{OZ} includes the input leakage current.

§ This is the increase in supply current for each input that is at the specified TTL voltage level, rather than V_{CC} or GND.

¶ Measured by the voltage drop between A and B terminals at the indicated current through the switch. ON-state resistance is determined by the lower of the voltages of the two (A or B) terminals.

SN74CB3T16211

24-BIT FET BUS SWITCH

2.5-V/3.3-V LOW-VOLTAGE BUS SWITCH WITH 5-V-TOLERANT LEVEL SHIFTER

SCDS147B – OCTOBER 2003 – REVISED JANUARY 2005

switching characteristics over recommended operating free-air temperature range (unless otherwise noted) (see Figure 2)

PARAMETER	FROM (INPUT)	TO (OUTPUT)	V _{CC} = 2.5 V ± 0.2 V		V _{CC} = 3.3 V ± 0.3 V		UNIT
			MIN	MAX	MIN	MAX	
t _{pd} [†]	A or B	B or A	0.15		0.25		ns
t _{en}	\overline{OE}	A or B	1	12	1	10	ns
t _{dis}	\overline{OE}	A or B	1	7.5	1	8.5	ns

[†] The propagation delay is the calculated RC time constant of the typical ON-state resistance of the switch and the specified load capacitance, when driven by an ideal voltage source (zero output impedance).

SN74CB3T16211
24-BIT FET BUS SWITCH
2.5-V/3.3-V LOW-VOLTAGE BUS SWITCH WITH 5-V-TOLERANT LEVEL SHIFTER

SCDS147B – OCTOBER 2003 – REVISED JANUARY 2005

PARAMETER MEASUREMENT INFORMATION

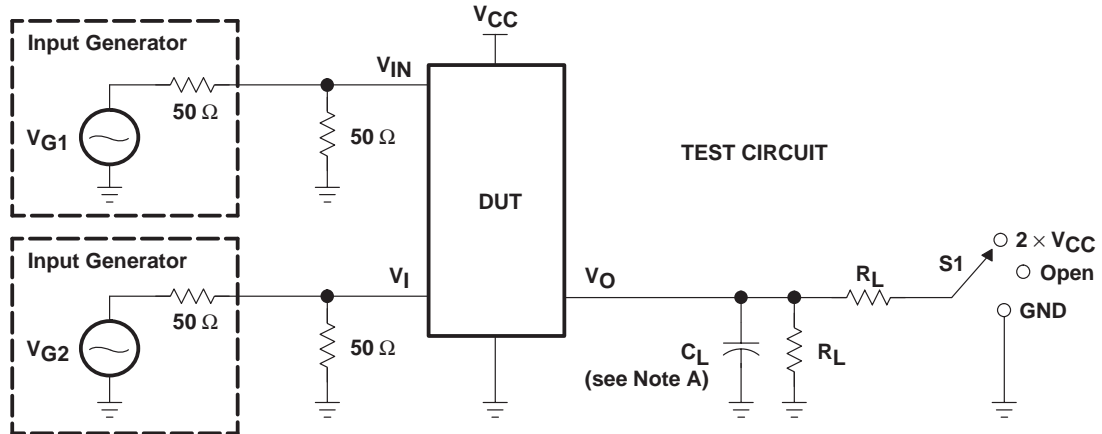

TEST	V _{CC}	S1	R _L	V _I	C _L	V _Δ
t _{pd} (s)	2.5 V ± 0.2 V	Open	500 Ω	3.6 V or GND	30 pF	
	3.3 V ± 0.3 V	Open	500 Ω	5.5 V or GND	50 pF	
t _{PLZ} /t _{PZL}	2.5 V ± 0.2 V	2 × V _{CC}	500 Ω	GND	30 pF	0.15 V
	3.3 V ± 0.3 V	2 × V _{CC}	500 Ω	GND	50 pF	0.3 V
t _{PHZ} /t _{PZH}	2.5 V ± 0.2 V	Open	500 Ω	3.6 V	30 pF	0.15 V
	3.3 V ± 0.3 V	Open	500 Ω	5.5 V	50 pF	0.3 V

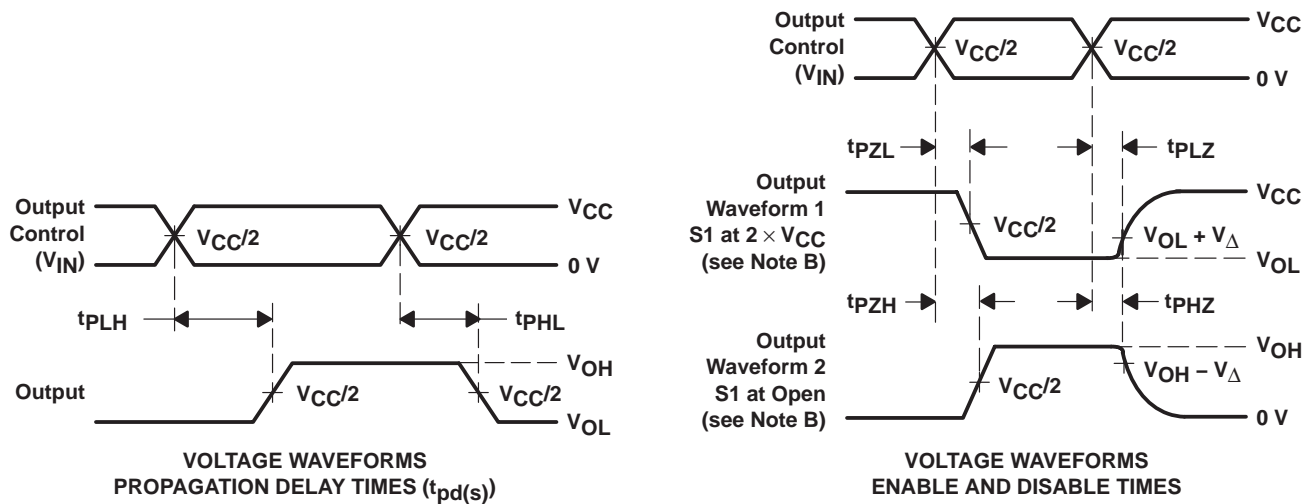

- NOTES: B. C_L includes probe and jig capacitance.
 C. Waveform 1 is for an output with internal conditions such that the output is low, except when disabled by the output control. Waveform 2 is for an output with internal conditions such that the output is high, except when disabled by the output control.
 D. All input pulses are supplied by generators having the following characteristics: PRR ≤ 10 MHz, Z_O = 50 Ω, t_r ≤ 2.5 ns, t_f ≤ 2.5 ns.
 E. The outputs are measured one at a time, with one transition per measurement.
 F. t_{PLZ} and t_{PHZ} are the same as t_{dis}.
 G. t_{PZL} and t_{PZH} are the same as t_{en}.
 H. t_{PLH} and t_{PHL} are the same as t_{pd}(s). The t_{pd} propagation delay is the calculated RC time constant of the typical ON-state resistance of the switch and the specified load capacitance, when driven by an ideal voltage source (zero output impedance).
 I. All parameters and waveforms are not applicable to all devices.

Figure 2. Test Circuit and Voltage Waveforms



TYPICAL CHARACTERISTICS

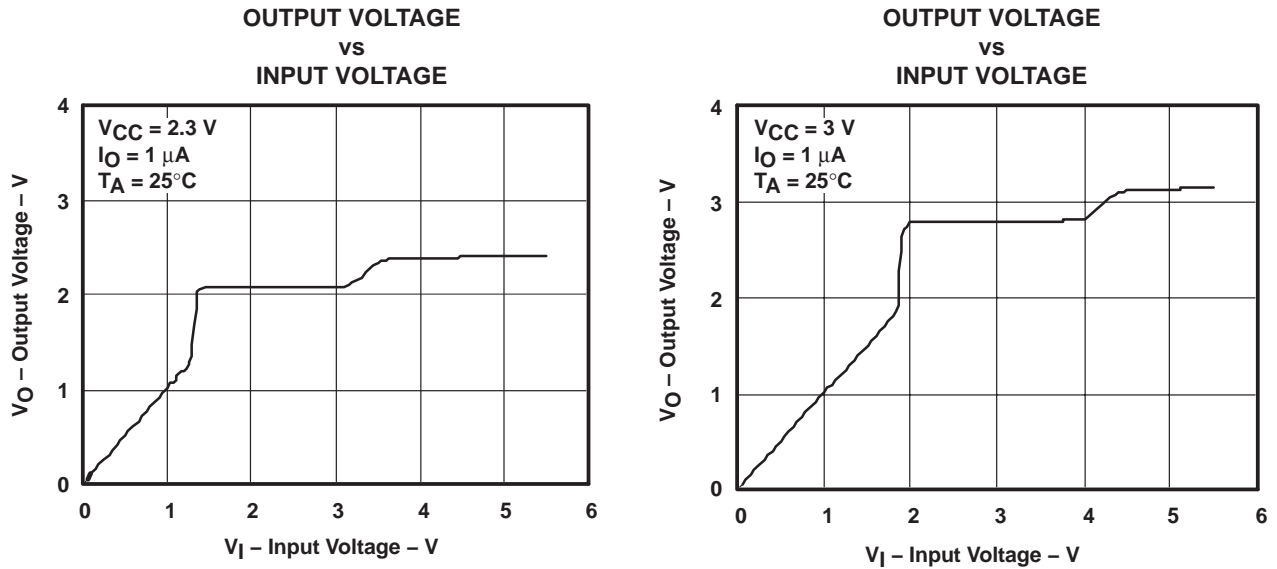

Figure 3. Data Output Voltage vs Data Input Voltage

SN74CB3T16211
24-BIT FET BUS SWITCH
2.5-V/3.3-V LOW-VOLTAGE BUS SWITCH WITH 5-V-TOLERANT LEVEL SHIFTER

SCDS147B – OCTOBER 2003 – REVISED JANUARY 2005

TYPICAL CHARACTERISTICS

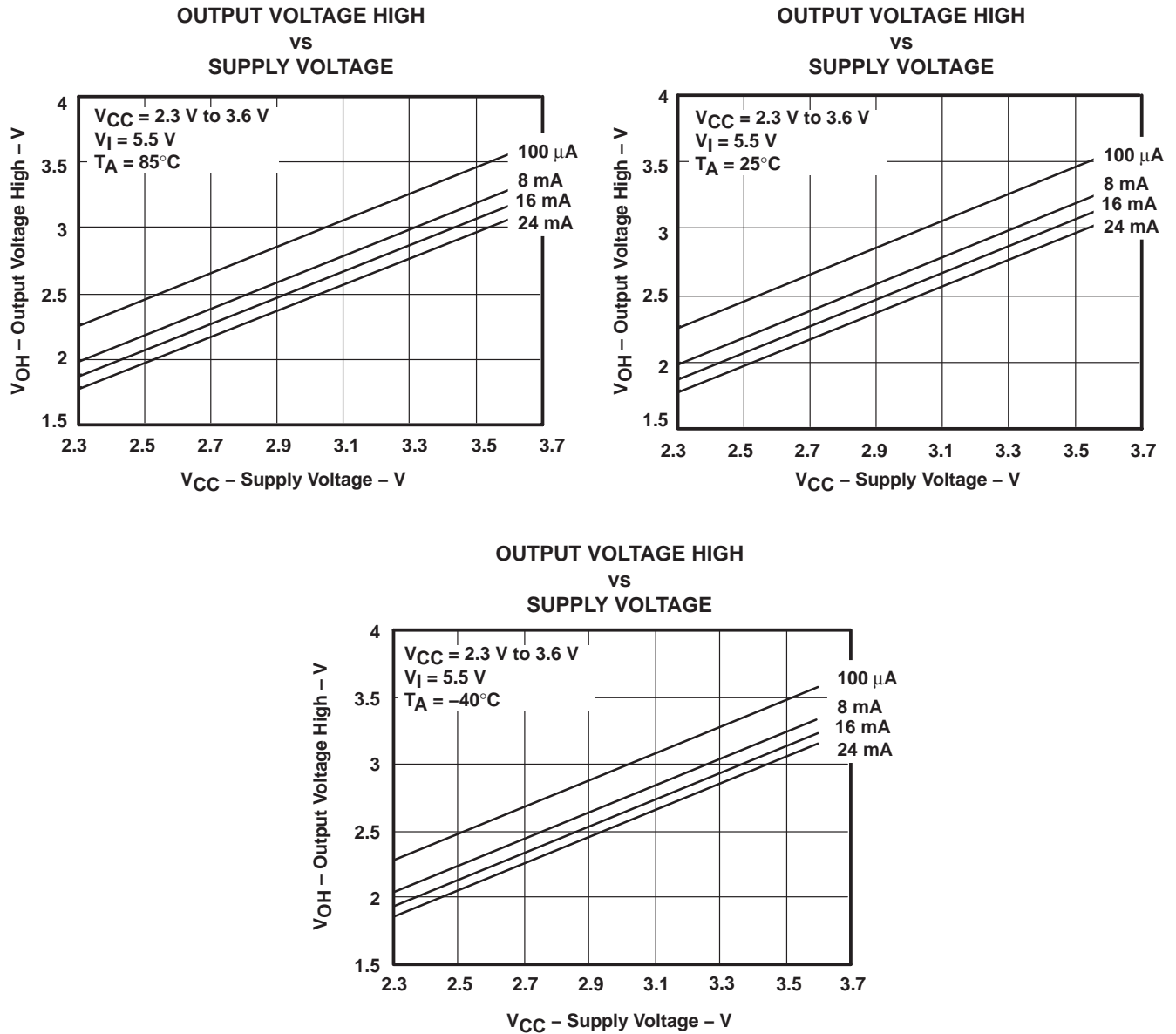

Figure 4. V_{OH} Values

PACKAGING INFORMATION

Orderable Device	Status ⁽¹⁾	Package Type	Package Drawing	Pins	Package Qty	Eco Plan ⁽²⁾	Lead/Ball Finish	MSL Peak Temp ⁽³⁾
SN74CB3T16211DGG	PREVIEW	TSSOP	DGG	56	35	Pb-Free (RoHS)	CU NIPDAU	Level-1-250C-UNLIM
SN74CB3T16211DGGR	ACTIVE	TSSOP	DGG	56	2000	Pb-Free (RoHS)	CU NIPDAU	Level-1-250C-UNLIM
SN74CB3T16211DGVR	ACTIVE	TVSOP	DGV	56	2000	Pb-Free (RoHS)	CU NIPDAU	Level-1-250C-UNLIM
SN74CB3T16211DL	ACTIVE	SSOP	DL	56	20	TBD	CU NIPDAU	Level-1-235C-UNLIM
SN74CB3T16211DLR	ACTIVE	SSOP	DL	56	1000	TBD	CU NIPDAU	Level-1-235C-UNLIM
SN74CB3T16211ZQLR	ACTIVE	VFBGA	ZQL	56	1000	Pb-Free (RoHS)	SNAGCU	Level-1-260C-UNLIM

⁽¹⁾ The marketing status values are defined as follows:

ACTIVE: Product device recommended for new designs.

LIFEBUY: TI has announced that the device will be discontinued, and a lifetime-buy period is in effect.

NRND: Not recommended for new designs. Device is in production to support existing customers, but TI does not recommend using this part in a new design.

PREVIEW: Device has been announced but is not in production. Samples may or may not be available.

OBSELETE: TI has discontinued the production of the device.

⁽²⁾ Eco Plan - The planned eco-friendly classification: Pb-Free (RoHS) or Green (RoHS & no Sb/Br) - please check <http://www.ti.com/productcontent> for the latest availability information and additional product content details.

TBD: The Pb-Free/Green conversion plan has not been defined.

Pb-Free (RoHS): TI's terms "Lead-Free" or "Pb-Free" mean semiconductor products that are compatible with the current RoHS requirements for all 6 substances, including the requirement that lead not exceed 0.1% by weight in homogeneous materials. Where designed to be soldered at high temperatures, TI Pb-Free products are suitable for use in specified lead-free processes.

Green (RoHS & no Sb/Br): TI defines "Green" to mean Pb-Free (RoHS compatible), and free of Bromine (Br) and Antimony (Sb) based flame retardants (Br or Sb do not exceed 0.1% by weight in homogeneous material)

⁽³⁾ MSL, Peak Temp. -- The Moisture Sensitivity Level rating according to the JEDEC industry standard classifications, and peak solder temperature.

Important Information and Disclaimer:The information provided on this page represents TI's knowledge and belief as of the date that it is provided. TI bases its knowledge and belief on information provided by third parties, and makes no representation or warranty as to the accuracy of such information. Efforts are underway to better integrate information from third parties. TI has taken and continues to take reasonable steps to provide representative and accurate information but may not have conducted destructive testing or chemical analysis on incoming materials and chemicals. TI and TI suppliers consider certain information to be proprietary, and thus CAS numbers and other limited information may not be available for release.

In no event shall TI's liability arising out of such information exceed the total purchase price of the TI part(s) at issue in this document sold by TI to Customer on an annual basis.

IMPORTANT NOTICE

Texas Instruments Incorporated and its subsidiaries (TI) reserve the right to make corrections, modifications, enhancements, improvements, and other changes to its products and services at any time and to discontinue any product or service without notice. Customers should obtain the latest relevant information before placing orders and should verify that such information is current and complete. All products are sold subject to TI's terms and conditions of sale supplied at the time of order acknowledgment.

TI warrants performance of its hardware products to the specifications applicable at the time of sale in accordance with TI's standard warranty. Testing and other quality control techniques are used to the extent TI deems necessary to support this warranty. Except where mandated by government requirements, testing of all parameters of each product is not necessarily performed.

TI assumes no liability for applications assistance or customer product design. Customers are responsible for their products and applications using TI components. To minimize the risks associated with customer products and applications, customers should provide adequate design and operating safeguards.

TI does not warrant or represent that any license, either express or implied, is granted under any TI patent right, copyright, mask work right, or other TI intellectual property right relating to any combination, machine, or process in which TI products or services are used. Information published by TI regarding third-party products or services does not constitute a license from TI to use such products or services or a warranty or endorsement thereof. Use of such information may require a license from a third party under the patents or other intellectual property of the third party, or a license from TI under the patents or other intellectual property of TI.

Reproduction of information in TI data books or data sheets is permissible only if reproduction is without alteration and is accompanied by all associated warranties, conditions, limitations, and notices. Reproduction of this information with alteration is an unfair and deceptive business practice. TI is not responsible or liable for such altered documentation.

Resale of TI products or services with statements different from or beyond the parameters stated by TI for that product or service voids all express and any implied warranties for the associated TI product or service and is an unfair and deceptive business practice. TI is not responsible or liable for any such statements.

Following are URLs where you can obtain information on other Texas Instruments products and application solutions:

Products		Applications	
Amplifiers	amplifier.ti.com	Audio	www.ti.com/audio
Data Converters	dataconverter.ti.com	Automotive	www.ti.com/automotive
DSP	dsp.ti.com	Broadband	www.ti.com/broadband
Interface	interface.ti.com	Digital Control	www.ti.com/digitalcontrol
Logic	logic.ti.com	Military	www.ti.com/military
Power Mgmt	power.ti.com	Optical Networking	www.ti.com/opticalnetwork
Microcontrollers	microcontroller.ti.com	Security	www.ti.com/security
		Telephony	www.ti.com/telephony
		Video & Imaging	www.ti.com/video
		Wireless	www.ti.com/wireless

Mailing Address: Texas Instruments
Post Office Box 655303 Dallas, Texas 75265