

## DUAL FET BUS SWITCH

### 2.5-V/3.3-V LOW-VOLTAGE HIGH-BANDWIDTH BUS SWITCH

Check for Samples: [SN74CB3Q3305](#)

#### FEATURES

- **High-Bandwidth Data Path (up to 500 MHz)**

For additional information regarding the performance characteristics of the CB3Q family, refer to the TI application report, *CBT-C*, *CB3T*, and *CB3Q Signal-Switch Families*, literature number SCDA008.

- **5-V Tolerant I/Os With Device Powered Up or Powered Down**
- **Low and Flat ON-State Resistance ( $r_{on}$ ) Characteristics Over Operating Range ( $r_{on} = 3 \Omega$  Typ)**
- **Rail-to-Rail Switching on Data I/O Ports**
  - 0- to 5-V Switching With 3.3-V  $V_{CC}$
  - 0- to 3.3-V Switching With 2.5-V  $V_{CC}$
- **Bidirectional Data Flow With Near-Zero Propagation Delay**
- **Low Input/Output Capacitance Minimizes Loading and Signal Distortion ( $C_{io(OFF)} = 3.5 \text{ pF}$  Typ)**
- **Fast Switching Frequency ( $f_{OE} = 20 \text{ MHz}$  Max)**
- **Data and Control Inputs Provide Undershoot Clamp Diodes**
- **Low Power Consumption ( $I_{CC} = 0.25 \text{ mA}$  Typ)**
- **$V_{CC}$  Operating Range From 2.3 V to 3.6 V**
- **Data I/Os Support 0- to 5-V Signaling Levels (0.8 V, 1.2 V, 1.5 V, 1.8 V, 2.5 V, 3.3 V, 5 V)**
- **Control Inputs Can Be Driven by TTL or 5-V/3.3-V CMOS Outputs**
- **$I_{off}$  Supports Partial-Power-Down Mode Operation**
- **Latch-Up Performance Exceeds 100 mA Per JESD 78, Class II**
- **ESD Performance Tested Per JESD 22**
  - 2000-V Human-Body Model (A114-B, Class II)
  - 1000-V Charged-Device Model (C101)
- **Supports Both Digital and Analog Applications: USB Interface, Differential Signal Interface, Bus Isolation, Low-Distortion Signal Gating**

**PW PACKAGE  
(TOP VIEW)**

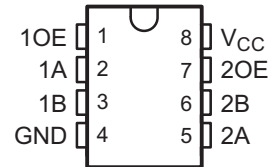

**DCU PACKAGE  
(TOP VIEW)**

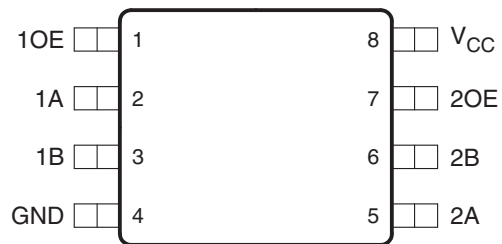

#### DESCRIPTION/ORDERING INFORMATION

The SN74CB3Q3305 is a high-bandwidth FET bus switch utilizing a charge pump to elevate the gate voltage of the pass transistor, providing a low and flat ON-state resistance ( $r_{on}$ ). The low and flat ON-state resistance allows for minimal propagation delay and supports rail-to-rail switching on the data input/output (I/O) ports. The device also features low data I/O capacitance to minimize capacitive loading and signal distortion on the data bus. Specifically designed to support high-bandwidth applications, the SN74CB3Q3305 provides an optimized interface solution ideally suited for broadband communications, networking, and data-intensive computing systems.

The SN74CB3Q3305 is organized as two 1-bit switches with separate output-enable (1OE, 2OE) inputs. It can be used as two 1-bit bus switches or as one 2-bit bus switch. When OE is high, the associated 1-bit bus switch is ON and the A port is connected to the B port, allowing bidirectional data flow between ports. When OE is low, the associated 1-bit bus switch is OFF and a high-impedance state exists between the A and B ports.



Please be aware that an important notice concerning availability, standard warranty, and use in critical applications of Texas Instruments semiconductor products and disclaimers thereto appears at the end of this data sheet.

**ORDERING INFORMATION**

T <sub>A</sub>	PACKAGE (1)		ORDERABLE PART NUMBER	TOP-SIDE MARKING (2)
-40°C to 85°C	TSSOP – PW	Tube	SN74CB3Q3305PW	BU305
		Tape and reel	SN74CB3Q3305PWR	
	VSSOP – DCU	Tape and reel	SN74CB3Q3305DCUR	GAR_

- (1) Package drawings, thermal data, and symbolization are available at [www.ti.com/packaging](http://www.ti.com/packaging).
- (2) The last character designates assembly/test site.

**DESCRIPTION/ORDERING INFORMATION (CONTINUED)**

This device is fully specified for partial-power-down applications using I<sub>off</sub>. The I<sub>off</sub> circuitry prevents damaging current backflow through the device when it is powered down. The device has isolation during power off.

To ensure the high-impedance state during power up or power down, OE should be tied to GND through a pull-down resistor; the minimum value of the resistor is determined by the current-sourcing capability of the driver.

**Table 1. FUNCTION TABLE (EACH BUS SWITCH)**

INPUT OE	INPUT/OUTPUT A	FUNCTION
H	B	A port = B port
L	Z	Disconnect

**LOGIC DIAGRAM (POSITIVE LOGIC)**

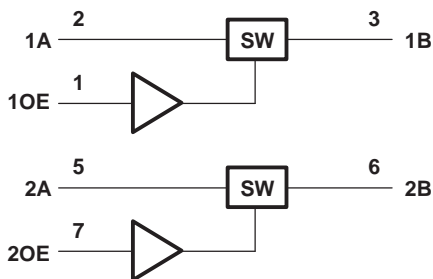

**SIMPLIFIED SCHEMATIC, EACH FET SWITCH (SW)**

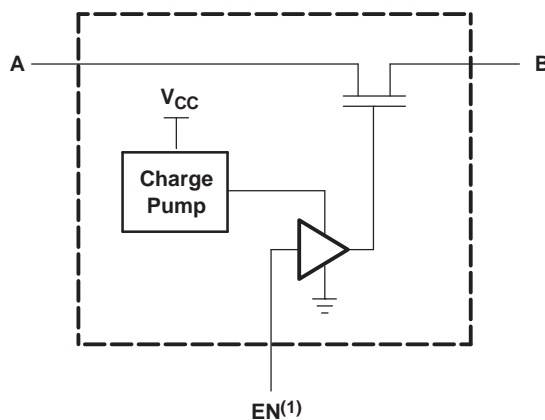

(1) EN is the internal enable signal applied to the switch.

## Absolute Maximum Ratings<sup>(1)</sup>

over operating free-air temperature range (unless otherwise noted)

		MIN	MAX	UNIT
$V_{CC}$	Supply voltage range	-0.5	4.6	V
$V_{IN}$	Control input voltage range <sup>(2) (3)</sup>	-0.5	7	V
$V_{I/O}$	Switch I/O voltage range <sup>(2) (3) (4)</sup>	-0.5	7	V
$I_{IK}$	Control input clamp current	$V_{IN} < 0$		-50 mA
$I_{I/OK}$	I/O port clamp current	$V_{I/O} < 0$		-50 mA
$I_{I/O}$	ON-state switch current <sup>(5)</sup>			±64 mA
	Continuous current through $V_{CC}$ or GND			±100 mA
$\theta_{JA}$	Package thermal impedance <sup>(6)</sup>			88 °C/W
$T_{stg}$	Storage temperature range	-65	150	°C

- (1) Stresses beyond those listed under "absolute maximum ratings" may cause permanent damage to the device. These are stress ratings only, and functional operation of the device at these or any other conditions beyond those indicated under "recommended operating conditions" is not implied. Exposure to absolute-maximum-rated conditions for extended periods may affect device reliability.
- (2) All voltages are with respect to ground, unless otherwise specified.
- (3) The input and output voltage ratings may be exceeded if the input and output clamp-current ratings are observed.
- (4)  $V_I$  and  $V_O$  are used to denote specific conditions for  $V_{I/O}$ .
- (5)  $I_I$  and  $I_O$  are used to denote specific conditions for  $I_{I/O}$ .
- (6) The package thermal impedance is calculated in accordance with JESD 51-7.

## Recommended Operating Conditions<sup>(1)</sup>

		MIN	MAX	UNIT	
$V_{CC}$	Supply voltage	2.3	3.6	V	
$V_{IH}$	High-level control input voltage	$V_{CC} = 2.3 \text{ V to } 2.7 \text{ V}$	1.7	5.5	V
		$V_{CC} = 2.7 \text{ V to } 3.6 \text{ V}$	2	5.5	
$V_{IL}$	Low-level control input voltage	$V_{CC} = 2.3 \text{ V to } 2.7 \text{ V}$	0	0.7	V
		$V_{CC} = 2.7 \text{ V to } 3.6 \text{ V}$	0	0.8	
$V_{I/O}$	Data input/output voltage	0	5.5	V	
$T_A$	Operating free-air temperature	-40	85	°C	

- (1) All unused control inputs of the device must be held at  $V_{CC}$  or GND to ensure proper device operation. Refer to the TI application report, *Implications of Slow or Floating CMOS Inputs*, literature number SCBA004.

## Electrical Characteristics<sup>(1)</sup>

over recommended operating free-air temperature range (unless otherwise noted)

PARAMETER		TEST CONDITIONS		MIN	TYP <sup>(2)</sup>	MAX	UNIT
$V_{IK}$		$V_{CC} = 3.6\text{ V}$ ,	$I_I = -18\text{ mA}$			-1.8	V
$I_{IN}$	Control inputs	$V_{CC} = 3.6\text{ V}$ ,	$V_{IN} = 0\text{ to }5.5\text{ V}$			$\pm 1$	$\mu\text{A}$
$I_{OZ}$ <sup>(3)</sup>		$V_{CC} = 3.6\text{ V}$ ,	$V_O = 0\text{ to }5.5\text{ V}$ , $V_I = 0$ ,	Switch OFF, $V_{IN} = V_{CC}\text{ or GND}$		$\pm 1$	$\mu\text{A}$
$I_{off}$		$V_{CC} = 0$ ,	$V_O = 0\text{ to }5.5\text{ V}$ , $V_I = 0$			1	$\mu\text{A}$
$I_{CC}$		$V_{CC} = 3.6\text{ V}$ ,	$I_{I/O} = 0$ , Switch ON or OFF,	$V_{IN} = V_{CC}\text{ or GND}$		0.25 0.7	mA
$\Delta I_{CC}$ <sup>(4)</sup>	Control inputs	$V_{CC} = 3.6\text{ V}$ , One input at 3 V, Other inputs at $V_{CC}$ or GND				25	$\mu\text{A}$
$I_{CCD}$ <sup>(5)</sup>	Per control input	$V_{CC} = 3.6\text{ V}$ ,	A and B ports open, Control input switching at 50% duty cycle		0.040	0.045	mA/ MHz
$C_{in}$	Control inputs	$V_{CC} = 3.3\text{ V}$ ,	$V_{IN} = 5.5\text{ V}$ , 3.3 V, or 0		2.5	3.5	pF
$C_{io(OFF)}$		$V_{CC} = 3.3\text{ V}$ ,	Switch OFF, $V_{IN} = V_{CC}\text{ or GND}$ ,	$V_{I/O} = 5.5\text{ V}$ , 3.3 V, or 0		3.5 5	pF
$C_{io(ON)}$		$V_{CC} = 3.3\text{ V}$ ,	Switch ON, $V_{IN} = V_{CC}\text{ or GND}$ ,	$V_{I/O} = 5.5\text{ V}$ , 3.3 V, or 0		8 10.5	pF
$r_{on}$ <sup>(6)</sup>		$V_{CC} = 2.3\text{ V}$ , TYP at $V_{CC} = 2.5\text{ V}$	$V_I = 0$ , $I_O = 30\text{ mA}$		3	8	$\Omega$
			$V_I = 1.7\text{ V}$ , $I_O = -15\text{ mA}$		3.5	9	
		$V_{CC} = 3\text{ V}$	$V_I = 0$ , $I_O = 30\text{ mA}$		3	6	
			$V_I = 2.4\text{ V}$ , $I_O = -15\text{ mA}$		3.5	8	

(1)  $V_{IN}$  and  $I_{IN}$  refer to control inputs.  $V_I$ ,  $V_O$ ,  $I_I$ , and  $I_O$  refer to data pins.

(2) All typical values are at  $V_{CC} = 3.3\text{ V}$  (unless otherwise noted),  $T_A = 25^\circ\text{C}$ .

(3) For I/O ports, the parameter  $I_{OZ}$  includes the input leakage current.

(4) This is the increase in supply current for each input that is at the specified TTL voltage level, rather than  $V_{CC}$  or GND.

(5) This parameter specifies the dynamic power-supply current associated with the operating frequency of a single control input (see Figure 2).

(6) Measured by the voltage drop between the A and B terminals at the indicated current through the switch. ON-state resistance is determined by the lower of the voltages of the two (A or B) terminals.

## Switching Characteristics

over recommended operating free-air temperature range (unless otherwise noted) (see Figure 3)

PARAMETER	FROM (INPUT)	TO (OUTPUT)	$V_{CC} = 2.5\text{ V} \pm 0.2\text{ V}$		$V_{CC} = 3.3\text{ V} \pm 0.3\text{ V}$		UNIT
			MIN	MAX	MIN	MAX	
$f_{OE}$ <sup>(1)</sup>	OE	A or B		10		20	MHz
$t_{pd}$ <sup>(2)</sup>	A or B	B or A		0.09		0.15	ns
$t_{en}$	OE	A or B	1	5	1	4.5	ns
$t_{dis}$	OE	A or B	1	4.5	1	5	ns

(1) Maximum switching frequency for control input ( $V_O > V_{CC}$ ,  $V_I = 5\text{ V}$ ,  $R_L \geq 1\text{ M}\Omega$ ,  $C_L = 0$ )

(2) The propagation delay is the calculated RC time constant of the typical ON-state resistance of the switch and the specified load capacitance, when driven by an ideal voltage source (zero output impedance).

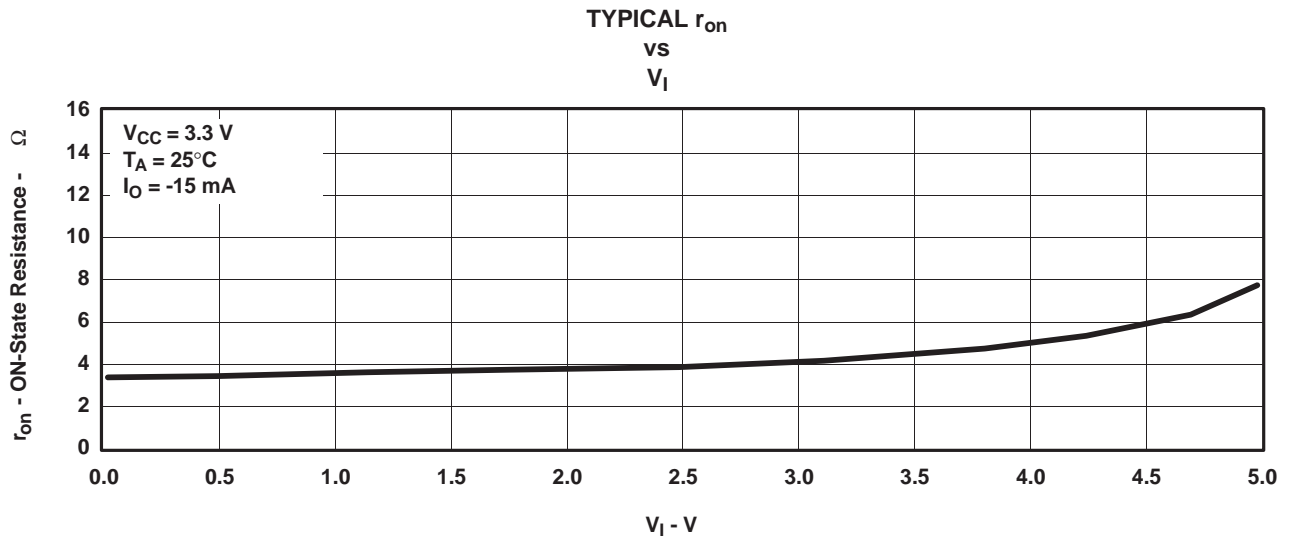

Figure 1. Typical  $r_{on}$  vs  $V_I$

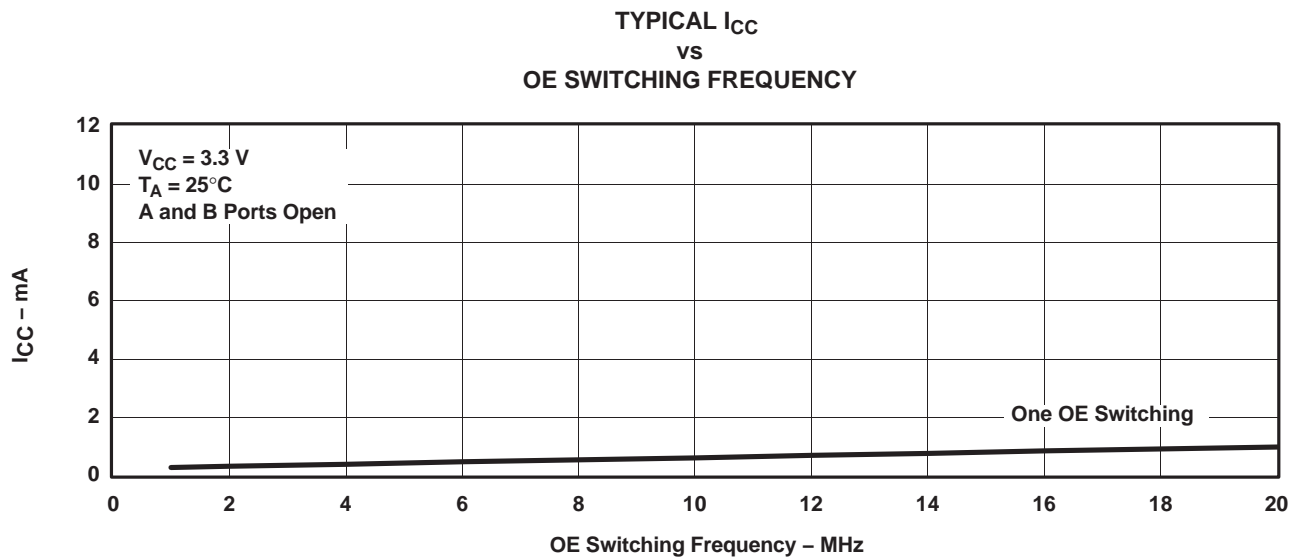
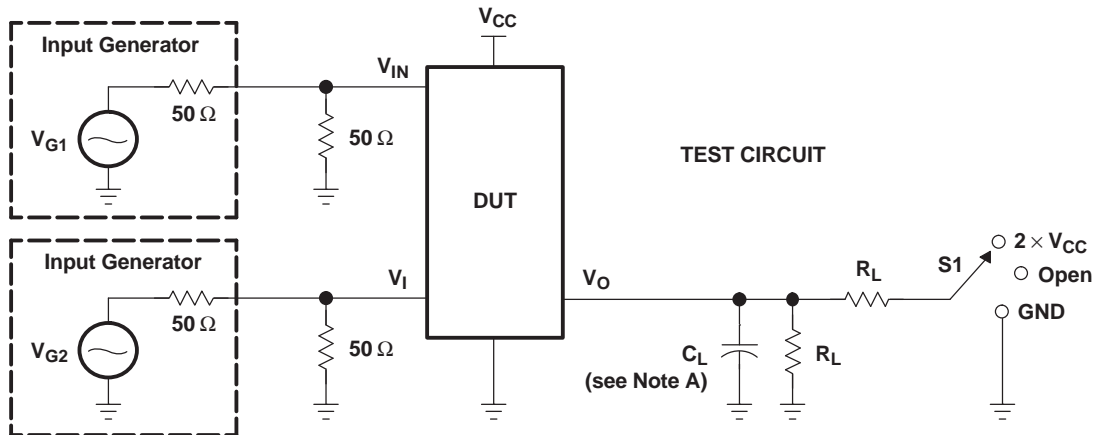
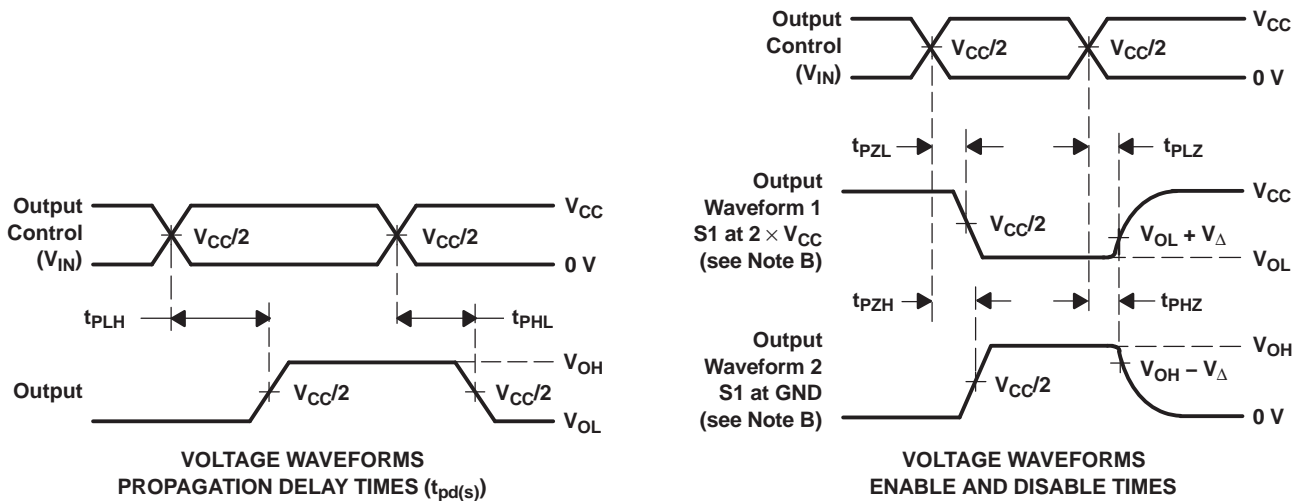

Figure 2. Typical  $I_{CC}$  vs OE Switching Frequency

PARAMETER MEASUREMENT INFORMATION



TEST	V <sub>CC</sub>	S1	R <sub>L</sub>	V <sub>I</sub>	C <sub>L</sub>	V <sub>Δ</sub>
t <sub>pd(s)</sub>	2.5 V ± 0.2 V	Open	500 Ω	V <sub>CC</sub> or GND	30 pF	
	3.3 V ± 0.3 V	Open	500 Ω	V <sub>CC</sub> or GND	50 pF	
t <sub>PLZ</sub> /t <sub>PZL</sub>	2.5 V ± 0.2 V	2 × V <sub>CC</sub>	500 Ω	GND	30 pF	0.15 V
	3.3 V ± 0.3 V	2 × V <sub>CC</sub>	500 Ω	GND	50 pF	0.3 V
t <sub>PHZ</sub> /t <sub>PZH</sub>	2.5 V ± 0.2 V	GND	500 Ω	V <sub>CC</sub>	30 pF	0.15 V
	3.3 V ± 0.3 V	GND	500 Ω	V <sub>CC</sub>	50 pF	0.3 V



- NOTES:
- A. C<sub>L</sub> includes probe and jig capacitance.
  - B. Waveform 1 is for an output with internal conditions such that the output is low, except when disabled by the output control. Waveform 2 is for an output with internal conditions such that the output is high, except when disabled by the output control.
  - C. All input pulses are supplied by generators having the following characteristics: PRR ≤ 10 MHz, Z<sub>O</sub> = 50 Ω, t<sub>r</sub> ≤ 2.5 ns, t<sub>f</sub> ≤ 2.5 ns.
  - D. The outputs are measured one at a time, with one transition per measurement.
  - E. t<sub>PLZ</sub> and t<sub>PHZ</sub> are the same as t<sub>dis</sub>.
  - F. t<sub>PZL</sub> and t<sub>PZH</sub> are the same as t<sub>en</sub>.
  - G. t<sub>PLH</sub> and t<sub>PHL</sub> are the same as t<sub>pd(s)</sub>. The t<sub>pd</sub> propagation delay is the calculated RC time constant of the typical ON-state resistance of the switch and the specified load capacitance, when driven by an ideal voltage source (zero output impedance).
  - H. All parameters and waveforms are not applicable to all devices.

Figure 3. Test Circuit and Voltage Waveforms

**PACKAGING INFORMATION**

Orderable Device	Status <sup>(1)</sup>	Package Type	Package Drawing	Pins	Package Qty	Eco Plan <sup>(2)</sup>	Lead/Ball Finish	MSL Peak Temp <sup>(3)</sup>
74CB3Q3305DCURE4	ACTIVE	US8	DCU	8	3000	Green (RoHS & no Sb/Br)	CU NIPDAU	Level-1-260C-UNLIM
74CB3Q3305DCURG4	ACTIVE	US8	DCU	8	3000	Green (RoHS & no Sb/Br)	CU NIPDAU	Level-1-260C-UNLIM
SN74CB3Q3305DCUR	ACTIVE	US8	DCU	8	3000	Green (RoHS & no Sb/Br)	CU NIPDAU	Level-1-260C-UNLIM
SN74CB3Q3305PW	ACTIVE	TSSOP	PW	8	150	Green (RoHS & no Sb/Br)	CU NIPDAU	Level-1-260C-UNLIM
SN74CB3Q3305PWE4	ACTIVE	TSSOP	PW	8	150	Green (RoHS & no Sb/Br)	CU NIPDAU	Level-1-260C-UNLIM
SN74CB3Q3305PWG4	ACTIVE	TSSOP	PW	8	150	Green (RoHS & no Sb/Br)	CU NIPDAU	Level-1-260C-UNLIM
SN74CB3Q3305PWR	ACTIVE	TSSOP	PW	8	2000	Green (RoHS & no Sb/Br)	CU NIPDAU	Level-1-260C-UNLIM
SN74CB3Q3305PWRE4	ACTIVE	TSSOP	PW	8	2000	Green (RoHS & no Sb/Br)	CU NIPDAU	Level-1-260C-UNLIM
SN74CB3Q3305PWRG4	ACTIVE	TSSOP	PW	8	2000	Green (RoHS & no Sb/Br)	CU NIPDAU	Level-1-260C-UNLIM

<sup>(1)</sup> The marketing status values are defined as follows:

**ACTIVE:** Product device recommended for new designs.

**LIFEBUY:** TI has announced that the device will be discontinued, and a lifetime-buy period is in effect.

**NRND:** Not recommended for new designs. Device is in production to support existing customers, but TI does not recommend using this part in a new design.

**PREVIEW:** Device has been announced but is not in production. Samples may or may not be available.

**OBsolete:** TI has discontinued the production of the device.

<sup>(2)</sup> Eco Plan - The planned eco-friendly classification: Pb-Free (RoHS), Pb-Free (RoHS Exempt), or Green (RoHS & no Sb/Br) - please check <http://www.ti.com/productcontent> for the latest availability information and additional product content details.

**TBD:** The Pb-Free/Green conversion plan has not been defined.

**Pb-Free (RoHS):** TI's terms "Lead-Free" or "Pb-Free" mean semiconductor products that are compatible with the current RoHS requirements for all 6 substances, including the requirement that lead not exceed 0.1% by weight in homogeneous materials. Where designed to be soldered at high temperatures, TI Pb-Free products are suitable for use in specified lead-free processes.

**Pb-Free (RoHS Exempt):** This component has a RoHS exemption for either 1) lead-based flip-chip solder bumps used between the die and package, or 2) lead-based die adhesive used between the die and leadframe. The component is otherwise considered Pb-Free (RoHS compatible) as defined above.

**Green (RoHS & no Sb/Br):** TI defines "Green" to mean Pb-Free (RoHS compatible), and free of Bromine (Br) and Antimony (Sb) based flame retardants (Br or Sb do not exceed 0.1% by weight in homogeneous material)

<sup>(3)</sup> MSL, Peak Temp. -- The Moisture Sensitivity Level rating according to the JEDEC industry standard classifications, and peak solder temperature.

**Important Information and Disclaimer:** The information provided on this page represents TI's knowledge and belief as of the date that it is provided. TI bases its knowledge and belief on information provided by third parties, and makes no representation or warranty as to the accuracy of such information. Efforts are underway to better integrate information from third parties. TI has taken and continues to take reasonable steps to provide representative and accurate information but may not have conducted destructive testing or chemical analysis on incoming materials and chemicals. TI and TI suppliers consider certain information to be proprietary, and thus CAS numbers and other limited information may not be available for release.

In no event shall TI's liability arising out of such information exceed the total purchase price of the TI part(s) at issue in this document sold by TI to Customer on an annual basis.

**TAPE AND REEL INFORMATION**

**REEL DIMENSIONS**

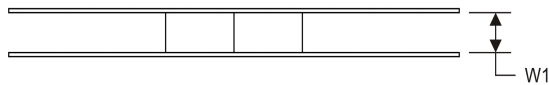
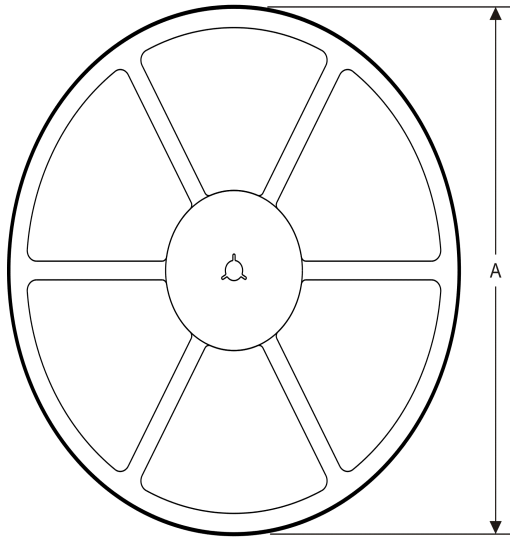

**TAPE DIMENSIONS**

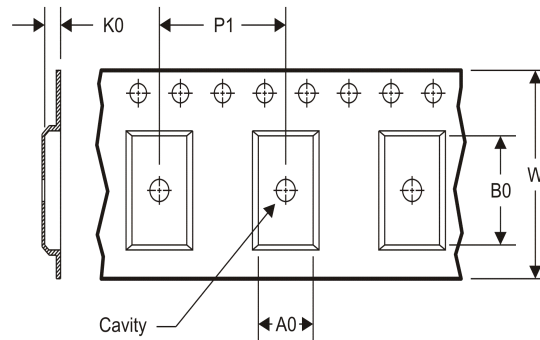

A0	Dimension designed to accommodate the component width
B0	Dimension designed to accommodate the component length
K0	Dimension designed to accommodate the component thickness
W	Overall width of the carrier tape
P1	Pitch between successive cavity centers

**TAPE AND REEL INFORMATION**

\*All dimensions are nominal

Device	Package Type	Package Drawing	Pins	SPQ	Reel Diameter (mm)	Reel Width W1 (mm)	A0 (mm)	B0 (mm)	K0 (mm)	P1 (mm)	W (mm)	Pin1 Quadrant
SN74CB3Q3305DCUR	US8	DCU	8	3000	180.0	8.4	2.25	3.35	1.05	4.0	8.0	Q3
SN74CB3Q3305PWR	TSSOP	PW	8	2000	330.0	12.4	7.0	3.6	1.6	8.0	12.0	Q1
SN74CB3Q3305PWR	TSSOP	PW	8	2000	330.0	12.4	7.0	3.6	1.6	8.0	12.0	Q1
SN74CB3Q3305PWRG4	TSSOP	PW	8	2000	330.0	12.4	7.0	3.6	1.6	8.0	12.0	Q1

**TAPE AND REEL BOX DIMENSIONS**



\*All dimensions are nominal

Device	Package Type	Package Drawing	Pins	SPQ	Length (mm)	Width (mm)	Height (mm)
SN74CB3Q3305DCUR	US8	DCU	8	3000	202.0	201.0	28.0
SN74CB3Q3305PWR	TSSOP	PW	8	2000	367.0	367.0	35.0
SN74CB3Q3305PWR	TSSOP	PW	8	2000	364.0	364.0	27.0
SN74CB3Q3305PW RG4	TSSOP	PW	8	2000	367.0	367.0	35.0

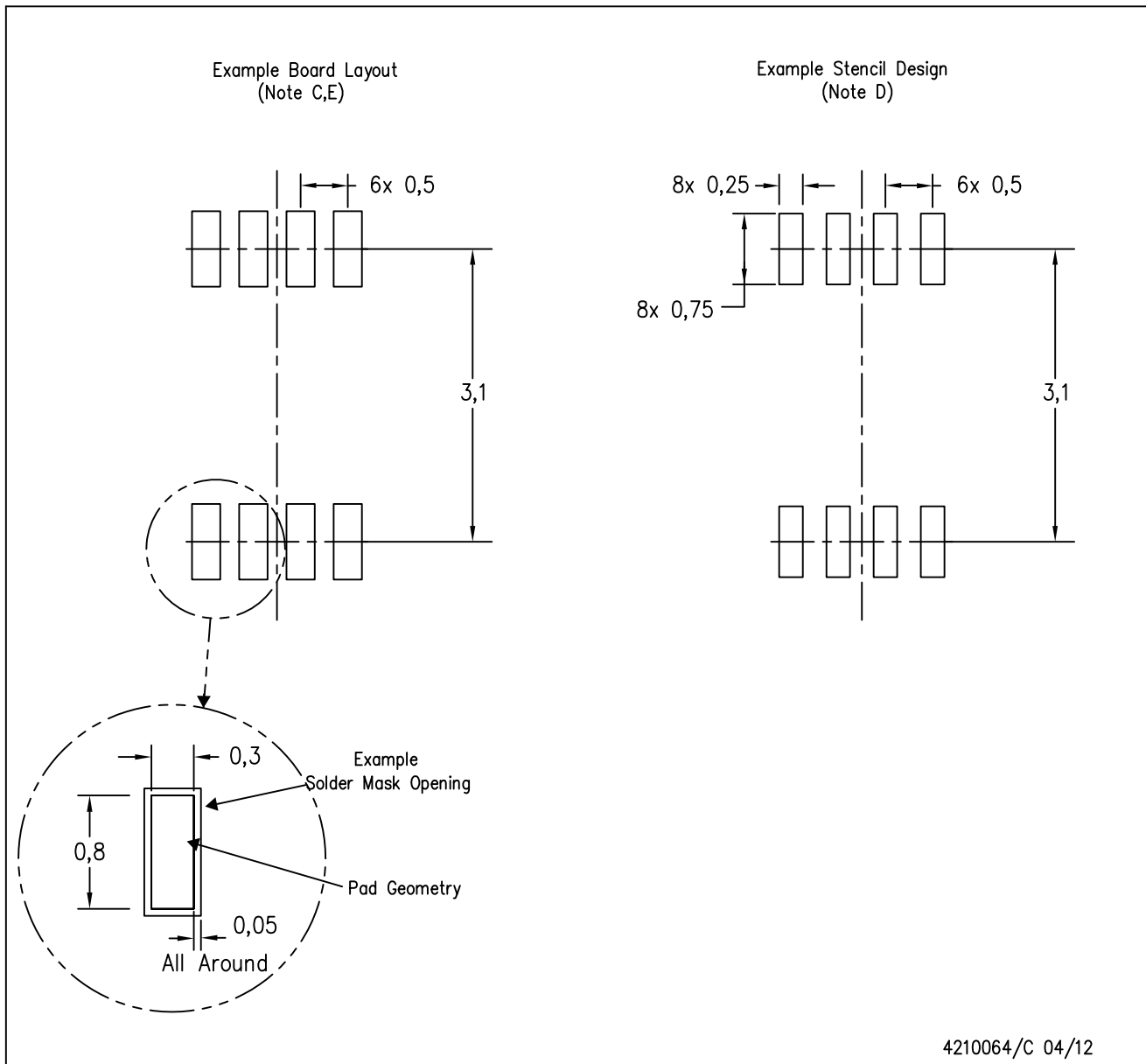

DCU (S-PDSO-G8)

PLASTIC SMALL OUTLINE PACKAGE (DIE DOWN)



4210064/C 04/12

- NOTES:
- A. All linear dimensions are in millimeters.
  - B. This drawing is subject to change without notice.
  - C. Publication IPC-7351 is recommended for alternate designs.
  - D. Laser cutting apertures with trapezoidal walls and also rounding corners will offer better paste release. Customers should contact their board assembly site for stencil design recommendations. Refer to IPC-7525 for other stencil recommendations.
  - E. Customers should contact their board fabrication site for solder mask tolerances between and around signal pads.

PW (R-PDSO-G8)

PLASTIC SMALL OUTLINE

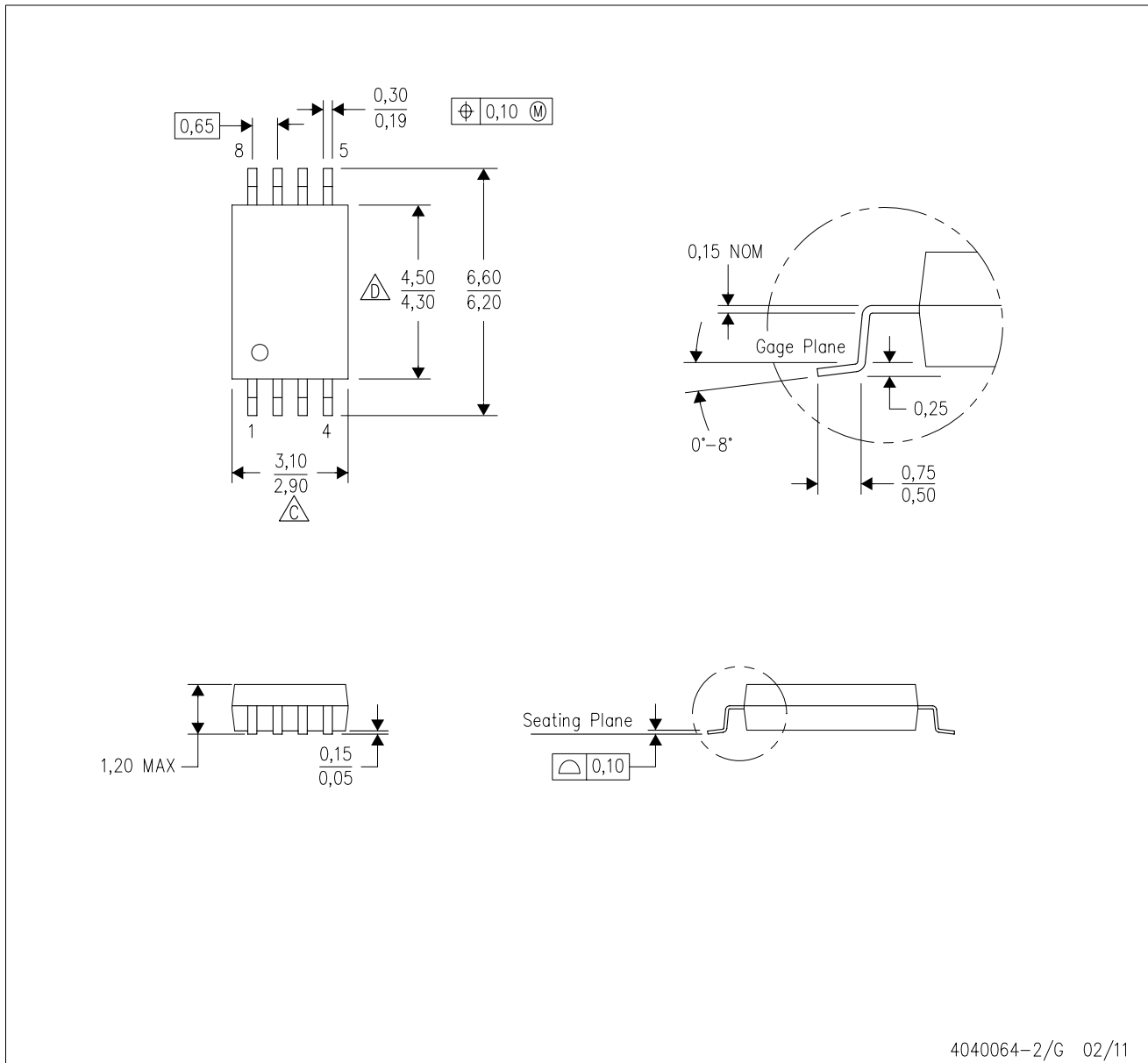

- NOTES:
- A. All linear dimensions are in millimeters. Dimensioning and tolerancing per ASME Y14.5M-1994.
  - B. This drawing is subject to change without notice.
  - C. Body length does not include mold flash, protrusions, or gate burrs. Mold flash, protrusions, or gate burrs shall not exceed 0,15 each side.
  - D. Body width does not include interlead flash. Interlead flash shall not exceed 0,25 each side.
  - E. Falls within JEDEC MO-153

## IMPORTANT NOTICE

Texas Instruments Incorporated and its subsidiaries (TI) reserve the right to make corrections, enhancements, improvements and other changes to its semiconductor products and services per JESD46C and to discontinue any product or service per JESD48B. Buyers should obtain the latest relevant information before placing orders and should verify that such information is current and complete. All semiconductor products (also referred to herein as "components") are sold subject to TI's terms and conditions of sale supplied at the time of order acknowledgment.

TI warrants performance of its components to the specifications applicable at the time of sale, in accordance with the warranty in TI's terms and conditions of sale of semiconductor products. Testing and other quality control techniques are used to the extent TI deems necessary to support this warranty. Except where mandated by applicable law, testing of all parameters of each component is not necessarily performed.

TI assumes no liability for applications assistance or the design of Buyers' products. Buyers are responsible for their products and applications using TI components. To minimize the risks associated with Buyers' products and applications, Buyers should provide adequate design and operating safeguards.

TI does not warrant or represent that any license, either express or implied, is granted under any patent right, copyright, mask work right, or other intellectual property right relating to any combination, machine, or process in which TI components or services are used. Information published by TI regarding third-party products or services does not constitute a license to use such products or services or a warranty or endorsement thereof. Use of such information may require a license from a third party under the patents or other intellectual property of the third party, or a license from TI under the patents or other intellectual property of TI.

Reproduction of significant portions of TI information in TI data books or data sheets is permissible only if reproduction is without alteration and is accompanied by all associated warranties, conditions, limitations, and notices. TI is not responsible or liable for such altered documentation. Information of third parties may be subject to additional restrictions.

Resale of TI components or services with statements different from or beyond the parameters stated by TI for that component or service voids all express and any implied warranties for the associated TI component or service and is an unfair and deceptive business practice. TI is not responsible or liable for any such statements.

Buyer acknowledges and agrees that it is solely responsible for compliance with all legal, regulatory and safety-related requirements concerning its products, and any use of TI components in its applications, notwithstanding any applications-related information or support that may be provided by TI. Buyer represents and agrees that it has all the necessary expertise to create and implement safeguards which anticipate dangerous consequences of failures, monitor failures and their consequences, lessen the likelihood of failures that might cause harm and take appropriate remedial actions. Buyer will fully indemnify TI and its representatives against any damages arising out of the use of any TI components in safety-critical applications.

In some cases, TI components may be promoted specifically to facilitate safety-related applications. With such components, TI's goal is to help enable customers to design and create their own end-product solutions that meet applicable functional safety standards and requirements. Nonetheless, such components are subject to these terms.

No TI components are authorized for use in FDA Class III (or similar life-critical medical equipment) unless authorized officers of the parties have executed a special agreement specifically governing such use.

Only those TI components which TI has specifically designated as military grade or "enhanced plastic" are designed and intended for use in military/aerospace applications or environments. Buyer acknowledges and agrees that any military or aerospace use of TI components which have **not** been so designated is solely at the Buyer's risk, and that Buyer is solely responsible for compliance with all legal and regulatory requirements in connection with such use.

TI has specifically designated certain components which meet ISO/TS16949 requirements, mainly for automotive use. Components which have not been so designated are neither designed nor intended for automotive use; and TI will not be responsible for any failure of such components to meet such requirements.

### Products

Audio	<a href="http://www.ti.com/audio">www.ti.com/audio</a>
Amplifiers	<a href="http://amplifier.ti.com">amplifier.ti.com</a>
Data Converters	<a href="http://dataconverter.ti.com">dataconverter.ti.com</a>
DLP® Products	<a href="http://www.dlp.com">www.dlp.com</a>
DSP	<a href="http://dsp.ti.com">dsp.ti.com</a>
Clocks and Timers	<a href="http://www.ti.com/clocks">www.ti.com/clocks</a>
Interface	<a href="http://interface.ti.com">interface.ti.com</a>
Logic	<a href="http://logic.ti.com">logic.ti.com</a>
Power Mgmt	<a href="http://power.ti.com">power.ti.com</a>
Microcontrollers	<a href="http://microcontroller.ti.com">microcontroller.ti.com</a>
RFID	<a href="http://www.ti-rfid.com">www.ti-rfid.com</a>
OMAP Mobile Processors	<a href="http://www.ti.com/omap">www.ti.com/omap</a>
Wireless Connectivity	<a href="http://www.ti.com/wirelessconnectivity">www.ti.com/wirelessconnectivity</a>

### Applications

Automotive and Transportation	<a href="http://www.ti.com/automotive">www.ti.com/automotive</a>
Communications and Telecom	<a href="http://www.ti.com/communications">www.ti.com/communications</a>
Computers and Peripherals	<a href="http://www.ti.com/computers">www.ti.com/computers</a>
Consumer Electronics	<a href="http://www.ti.com/consumer-apps">www.ti.com/consumer-apps</a>
Energy and Lighting	<a href="http://www.ti.com/energy">www.ti.com/energy</a>
Industrial	<a href="http://www.ti.com/industrial">www.ti.com/industrial</a>
Medical	<a href="http://www.ti.com/medical">www.ti.com/medical</a>
Security	<a href="http://www.ti.com/security">www.ti.com/security</a>
Space, Avionics and Defense	<a href="http://www.ti.com/space-avionics-defense">www.ti.com/space-avionics-defense</a>
Video and Imaging	<a href="http://www.ti.com/video">www.ti.com/video</a>

**TI E2E Community** [e2e.ti.com](http://e2e.ti.com)