

# SN54BCT652, SN74BCT652 OCTAL BUS TRANSCEIVERS AND REGISTERS WITH 3-STATE OUTPUTS

SCBS038A – AUGUST 1989 – REVISED NOVEMBER 1993

- State-of-the-Art BiCMOS Design Significantly Reduces  $I_{CCZ}$
- ESD Protection Exceeds 2000 V Per MIL-STD-883C, Method 3015; Exceeds 200 V Using Machine Model ( $C = 200$  pF,  $R = 0$ )
- Independent Registers and Enables for A and B Buses
- Multiplexed Real-Time and Stored Data
- Power-Up High-Impedance Mode
- Package Options Include Plastic Small-Outline (DW) Packages, Ceramic Chip Carriers (FK) and Flatpacks (W), and Standard Plastic and Ceramic 300-mil DIPs (JT, NT)

## description

These devices consist of bus transceiver circuits, D-type flip-flops, and control circuitry arranged for multiplexed transmission of data directly from the data bus or from the internal storage registers.

Output-enable (OEAB and  $\overline{OEBA}$ ) inputs are provided to control the transceiver functions. Select-control (SAB and SBA) inputs are provided to select whether real-time or stored data is transferred. The circuitry used for select control eliminates the typical decoding glitch that occurs in a multiplexer during the transition between stored and real-time data. A low input selects real-time data, and a high input selects stored data. Figure 1 illustrates the four fundamental bus-management functions that can be performed with the 'BCT652.

Data on the A or B data bus, or both, can be stored in the internal D-type flip-flops by low-to-high transitions at the appropriate clock (CLKAB or CLKBA) inputs regardless of the select- or enable-control pins. When SAB and SBA are in the real-time transfer mode, it is possible to store data without using the internal D-type flip-flops by simultaneously enabling OEAB and  $\overline{OEBA}$ . In this configuration each output reinforces its input. Therefore, when all other data sources to the two sets of bus lines are at high impedance, each set of bus lines remain at its last state.

The SN54BCT652 is characterized for operation over the full military temperature range of  $-55^{\circ}\text{C}$  to  $125^{\circ}\text{C}$ . The SN74BCT652 is characterized for operation from  $0^{\circ}\text{C}$  to  $70^{\circ}\text{C}$ .

SN54BCT652 . . . JT OR W PACKAGE  
SN74BCT652 . . . DW OR NT PACKAGE  
(TOP VIEW)

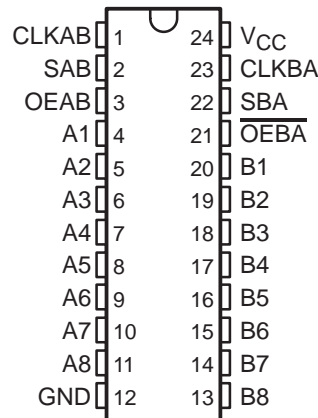

SN54BCT652 . . . FK PACKAGE  
(TOP VIEW)

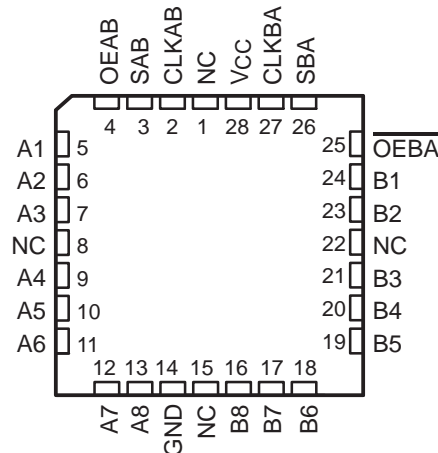

NC – No internal connection

# SN54BCT652, SN74BCT652 OCTAL BUS TRANSCEIVERS AND REGISTERS WITH 3-STATE OUTPUTS

SCBS038A – AUGUST 1989 – REVISED NOVEMBER 1993

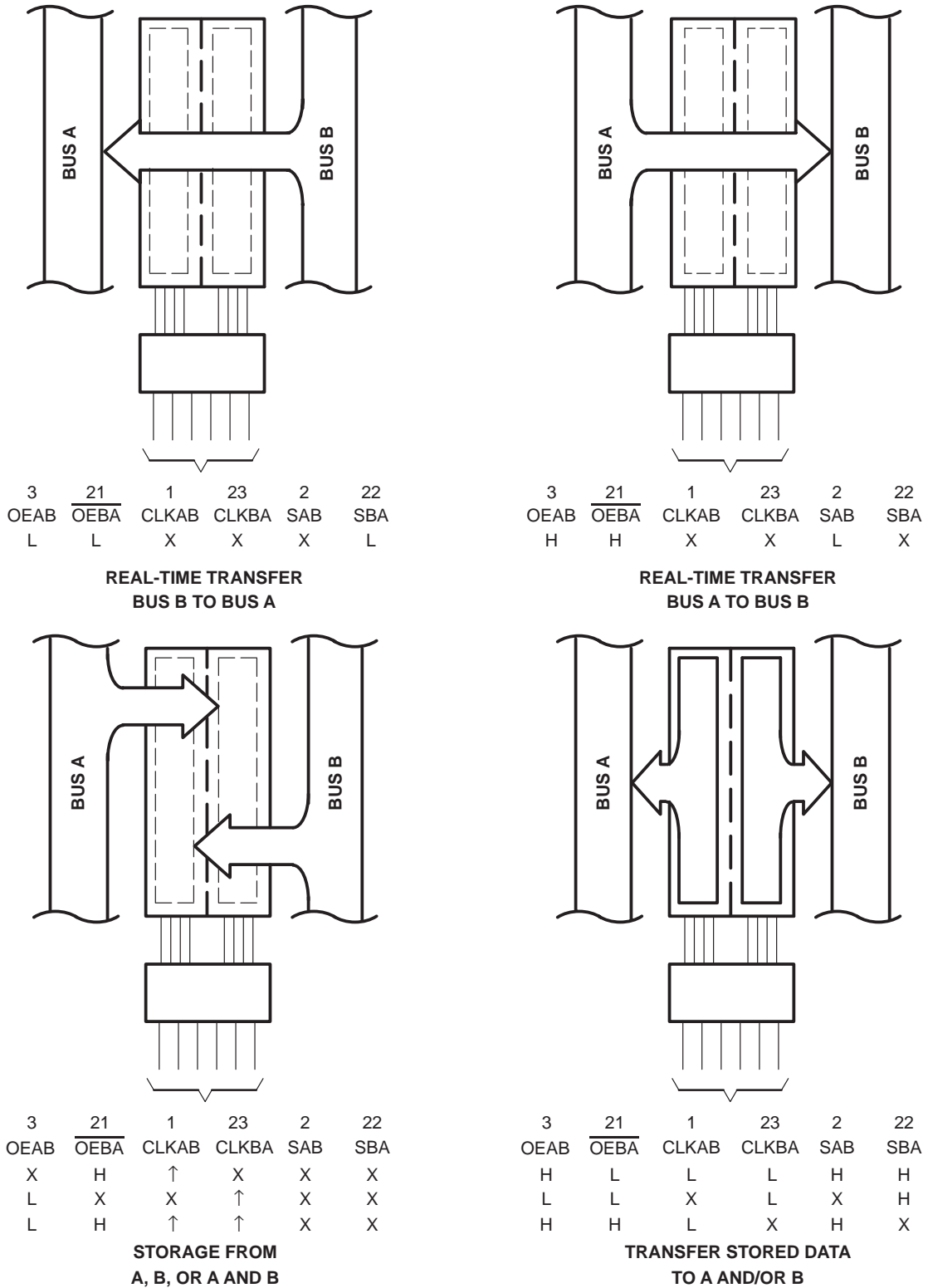

**Figure 1. Bus-Management Functions**

Pin numbers shown are for the DW, JT, NT, and W packages.

# SN54BCT652, SN74BCT652 OCTAL BUS TRANSCEIVERS AND REGISTERS WITH 3-STATE OUTPUTS

SCBS038A – AUGUST 1989 – REVISED NOVEMBER 1993

FUNCTION TABLE

INPUTS						DATA I/O†		OPERATION OR FUNCTION
OEAB	OEBA	CLKAB	CLKBA	SAB	SBA	A1 THRU A8	B1 THRU B8	
L	H	H or L	H or L	X	X	Input	Input	Isolation
L	H	↑	↑	X	X	Input	Input	Store A and B data
X	H	↑	H or L	X	X	Input	Unspecified‡	Store A, hold B
H	H	↑	↑	X‡	X	Input	Output	Store A in both registers
L	X	H or L	↑	X	X	Unspecified‡	Input	Hold A, store B
L	L	↑	↑	X	X‡	Output	Input	Store B in both registers
L	L	X	X	X	L	Output	Input	Real-time B data to A bus
L	L	X	H or L	X	H	Output	Input	Stored B data to A bus
H	H	X	X	L	X	Input	Output	Real-time A data to B bus
H	H	H or L	X	H	X	Input	Output	Stored A data to B bus
H	L	H or L	H or L	H	H	Output	Output	Stored A data to B bus and stored B data to A bus

† The data output functions may be enabled or disabled by a variety of level combinations at the OEAB or OEBA inputs. Data input functions are always enabled; i.e., data at the bus pins is stored on every low-to-high transition on the clock inputs.

‡ Select control = L; clocks can occur simultaneously.

Select control = H; clocks must be staggered in order to load both registers.

## logic symbols§

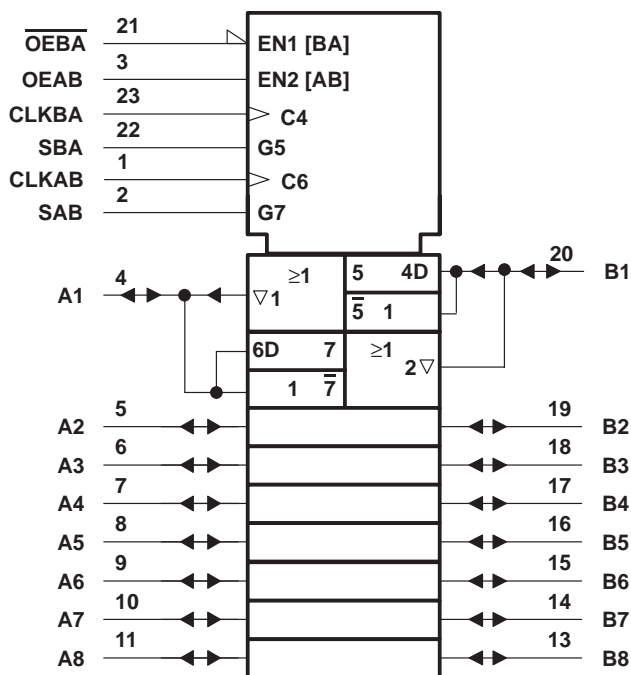

§ This symbol is in accordance with ANSI/IEEE Std 91-1984 and IEC Publication 617-12. Pin numbers shown are for the DW, JT, NT, and W packages.



# SN54BCT652, SN74BCT652 OCTAL BUS TRANSCEIVERS AND REGISTERS WITH 3-STATE OUTPUTS

SCBS038A – AUGUST 1989 – REVISED NOVEMBER 1993

## recommended operating conditions

		SN54BCT652			SN74BCT652			UNIT
		MIN	NOM	MAX	MIN	NOM	MAX	
$V_{CC}$	Supply voltage	4.5	5	5.5	4.5	5	5.5	V
$V_{IH}$	High-level input voltage	2			2			V
$V_{IL}$	Low-level input voltage			0.8			0.8	V
$I_{IK}$	Input clamp current			-18			-18	mA
$I_{OH}$	High-level output current			-12			-15	mA
$I_{OL}$	Low-level output current			48			64	mA
$T_A$	Operating free-air temperature	-55		125	0		70	°C

## electrical characteristics over recommended operating free-air temperature range (unless otherwise noted)

PARAMETER		TEST CONDITIONS		SN54BCT652		SN74BCT652		UNIT
				MIN	TYP†	MAX	MIN	
$V_{IK}$		$V_{CC} = 4.5\text{ V}$ ,	$I_I = -18\text{ mA}$			-1.2	-1.2	V
$V_{OH}$		$V_{CC} = 4.5\text{ V}$	$I_{OH} = -3\text{ mA}$	2.4	3.3	2.4	3.3	V
			$I_{OH} = -12\text{ mA}$	2	3.2			
			$I_{OH} = -15\text{ mA}$			2	3.1	
$V_{OL}$		$V_{CC} = 4.5\text{ V}$	$I_{OL} = 48\text{ mA}$	0.38	0.55			V
			$I_{OL} = 64\text{ mA}$			0.42	0.55	
$I_I$	A or B port	$V_{CC} = 5.5\text{ V}$ ,	$V_I = 5.5\text{ V}$		1		1	mA
	Control inputs				1		1	
$I_{IH}‡$	A or B port	$V_{CC} = 5.5\text{ V}$ ,	$V_I = 2.7\text{ V}$		70		70	µA
	Control inputs				20		20	
$I_{IL}‡$	A or B port	$V_{CC} = 5.5\text{ V}$ ,	$V_I = 0.5\text{ V}$		-0.7		-0.7	mA
	Control inputs				-0.7		-0.7	
$I_{OS}§$		$V_{CC} = 5.5\text{ V}$ ,	$V_O = 0$	-100	-225	-100	-225	mA
$I_{CCL}$	A or B port	$V_{CC} = 5.5\text{ V}$ ,	$V_I = 0$	43	69	43	69	mA
$I_{CCH}$	A or B port	$V_{CC} = 5.5\text{ V}$ ,	$V_I = 4.5\text{ V}$	6	10	6	10	mA
$I_{CCZ}$	A or B port	$V_{CC} = 5.5\text{ V}$ ,	$V_I = 0$	10	17	10	17	mA
$C_i$	Control inputs	$V_{CC} = 5\text{ V}$ ,	$V_I = 2.5\text{ V}$ or $0.5\text{ V}$	6		6		pF
$C_{io}$	A or B port	$V_{CC} = 5\text{ V}$ ,	$V_O = 2.5\text{ V}$ or $0.5\text{ V}$	14		14		pF

† All typical values are at  $V_{CC} = 5\text{ V}$ ,  $T_A = 25^\circ\text{C}$ .

‡ For I/O ports, the parameters  $I_{IH}$  and  $I_{IL}$  include the off-state output current.

§ Not more than one output should be tested at a time, and the duration of the test should not exceed one second.

## timing requirements over recommended ranges of supply voltage and operating free-air temperature (unless otherwise noted)

		$V_{CC} = 5\text{ V}$ , $T_A = 25^\circ\text{C}$		SN54BCT652		SN74BCT652		UNIT
		MIN	MAX	MIN	MAX	MIN	MAX	
$f_{\text{clock}}$	Clock frequency	0	77	0	77	0	77	MHz
$t_w$	Pulse duration, CLK high or low	6.5		7		6.5		ns
$t_{su}$	Setup time, A or B before CLKAB↑ or CLKBA↑	5		6		5		ns
$t_h$	Hold time, A or B after CLKAB↑ or CLKBA↑	1		1		1		ns



# SN54BCT652, SN74BCT652 OCTAL BUS TRANSCEIVERS AND REGISTERS WITH 3-STATE OUTPUTS

SCBS038A – AUGUST 1989 – REVISED NOVEMBER 1993

switching characteristics over recommended ranges of supply voltage and operating free-air temperature,  $C_L = 50$  pF (unless otherwise noted) (see Note 2)

PARAMETER	FROM (INPUT)	TO (OUTPUT)	$V_{CC} = 5$ V, $T_A = 25^\circ$ C			SN54BCT652		SN74BCT652		UNIT
			MIN	TYP	MIN	MIN	MAX	MIN	MAX	
$f_{max}$			77			77		77		MHz
$t_{PLH}$	CLKBA	A	2.6	6.9	8.9	2.6	11.6	2.6	10.5	ns
$t_{PHL}$			2.8	6.8	8.8	2.8	10.7	2.8	9.9	
$t_{PLH}$	CLKAB	B	2.6	6.9	8.9	2.6	11.6	2.6	10.5	ns
$t_{PHL}$			2.8	6.8	8.8	2.8	10.7	2.8	9.9	
$t_{PLH}$	A	B	1.7	5.8	7.5	1.7	10.3	1.7	8.9	ns
$t_{PHL}$			2.4	6.5	8.2	2.4	11	2.4	9.8	
$t_{PLH}$	B	A	1.7	5.8	7.5	1.7	10.3	1.7	8.9	ns
$t_{PHL}$			2.4	6.5	8.2	2.4	11	2.4	9.8	
$t_{PLH}$	SBA $\dagger$ (with B high)	A	3.5	8.8	10.8	3.5	14.2	3.5	13.1	ns
$t_{PHL}$			2.4	5.9	7.7	2.4	9.1	2.4	8.5	
$t_{PLH}$	SBA $\dagger$ (with B low)	A	3	7.6	9.7	3	12.4	3	11.3	ns
$t_{PHL}$			3.8	8.3	10.4	3.8	12.9	3.8	12.5	
$t_{PLH}$	SAB $\dagger$ (with A high)	B	3.5	8.8	10.8	3.5	14.2	3.5	13.1	ns
$t_{PHL}$			2.4	5.9	7.7	2.4	9.1	2.4	8.5	
$t_{PLH}$	SAB $\dagger$ (with A low)	B	3	7.6	9.7	3	12.4	3	11.3	ns
$t_{PHL}$			3.8	8.3	10.4	3.8	12.9	3.8	12.5	
$t_{PZH}$	OEBA	A	2.5	7.2	8.9	2.5	11.2	2.5	10.6	ns
$t_{PZL}$			3.2	8.1	10.1	3.2	12.6	3.2	12	
$t_{PHZ}$	$\overline{OEBA}$	A	2.8	6.7	8.6	2.8	10.9	2.8	10	ns
$t_{PLZ}$			2.4	6.3	8.4	2.4	10.5	2.4	9.5	
$t_{PZH}$	OEAB	B	1.5	5.4	7.1	1.5	9	1.5	8.1	ns
$t_{PZL}$			2.3	6.2	8.1	2.3	10.3	2.3	9.3	
$t_{PHZ}$	OEAB	B	3.5	8.2	10	3.5	12.2	3.5	11.6	ns
$t_{PLZ}$			2.8	7.2	9.5	2.8	12	2.8	11.3	

$\dagger$  These parameters are measured with the internal output state of the storage register opposite to that of the bus input.

NOTE 2: Load circuits and voltage waveforms are shown in Section 1.

PACKAGING INFORMATION

Orderable Device	Status <sup>(1)</sup>	Package Type	Package Drawing	Pins	Package Qty	Eco Plan <sup>(2)</sup>	Lead/Ball Finish	MSL Peak Temp <sup>(3)</sup>
5962-9155301M3A	ACTIVE	LCCC	FK	28	1	TBD	POST-PLATE	N / A for Pkg Type
5962-9155301MKA	ACTIVE	CDIP	JT	24	1	TBD	A42 SNPB	N / A for Pkg Type
5962-9155301MLA	ACTIVE	CFP	W	24	1	TBD	A42	N / A for Pkg Type
SN74BCT652DW	ACTIVE	SOIC	DW	24	25	Green (RoHS & no Sb/Br)	CU NIPDAU	Level-1-260C-UNLIM
SN74BCT652DWE4	ACTIVE	SOIC	DW	24	25	Green (RoHS & no Sb/Br)	CU NIPDAU	Level-1-260C-UNLIM
SN74BCT652DWG4	ACTIVE	SOIC	DW	24	25	Green (RoHS & no Sb/Br)	CU NIPDAU	Level-1-260C-UNLIM
SN74BCT652DWR	ACTIVE	SOIC	DW	24	2000	Green (RoHS & no Sb/Br)	CU NIPDAU	Level-1-260C-UNLIM
SN74BCT652DWRE4	ACTIVE	SOIC	DW	24	2000	Green (RoHS & no Sb/Br)	CU NIPDAU	Level-1-260C-UNLIM
SN74BCT652DWRG4	ACTIVE	SOIC	DW	24	2000	Green (RoHS & no Sb/Br)	CU NIPDAU	Level-1-260C-UNLIM
SN74BCT652NT	ACTIVE	PDIP	NT	24	15	Pb-Free (RoHS)	CU NIPDAU	N / A for Pkg Type
SN74BCT652NTE4	ACTIVE	PDIP	NT	24	15	Pb-Free (RoHS)	CU NIPDAU	N / A for Pkg Type
SNJ54BCT652FK	ACTIVE	LCCC	FK	28	1	TBD	POST-PLATE	N / A for Pkg Type
SNJ54BCT652JT	ACTIVE	CDIP	JT	24	1	TBD	A42 SNPB	N / A for Pkg Type
SNJ54BCT652W	ACTIVE	CFP	W	24	1	TBD	A42	N / A for Pkg Type

<sup>(1)</sup> The marketing status values are defined as follows:

**ACTIVE:** Product device recommended for new designs.

**LIFEBUY:** TI has announced that the device will be discontinued, and a lifetime-buy period is in effect.

**NRND:** Not recommended for new designs. Device is in production to support existing customers, but TI does not recommend using this part in a new design.

**PREVIEW:** Device has been announced but is not in production. Samples may or may not be available.

**OBSOLETE:** TI has discontinued the production of the device.

<sup>(2)</sup> Eco Plan - The planned eco-friendly classification: Pb-Free (RoHS), Pb-Free (RoHS Exempt), or Green (RoHS & no Sb/Br) - please check <http://www.ti.com/productcontent> for the latest availability information and additional product content details.

**TBD:** The Pb-Free/Green conversion plan has not been defined.

**Pb-Free (RoHS):** TI's terms "Lead-Free" or "Pb-Free" mean semiconductor products that are compatible with the current RoHS requirements for all 6 substances, including the requirement that lead not exceed 0.1% by weight in homogeneous materials. Where designed to be soldered at high temperatures, TI Pb-Free products are suitable for use in specified lead-free processes.

**Pb-Free (RoHS Exempt):** This component has a RoHS exemption for either 1) lead-based flip-chip solder bumps used between the die and package, or 2) lead-based die adhesive used between the die and leadframe. The component is otherwise considered Pb-Free (RoHS compatible) as defined above.

**Green (RoHS & no Sb/Br):** TI defines "Green" to mean Pb-Free (RoHS compatible), and free of Bromine (Br) and Antimony (Sb) based flame retardants (Br or Sb do not exceed 0.1% by weight in homogeneous material)

<sup>(3)</sup> MSL, Peak Temp. -- The Moisture Sensitivity Level rating according to the JEDEC industry standard classifications, and peak solder temperature.

**Important Information and Disclaimer:**The information provided on this page represents TI's knowledge and belief as of the date that it is provided. TI bases its knowledge and belief on information provided by third parties, and makes no representation or warranty as to the accuracy of such information. Efforts are underway to better integrate information from third parties. TI has taken and continues to take reasonable steps to provide representative and accurate information but may not have conducted destructive testing or chemical analysis on incoming materials and chemicals. TI and TI suppliers consider certain information to be proprietary, and thus CAS numbers and other limited information may not be available for release.

In no event shall TI's liability arising out of such information exceed the total purchase price of the TI part(s) at issue in this document sold by TI to Customer on an annual basis.

**TAPE AND REEL INFORMATION**



**QUADRANT ASSIGNMENTS FOR PIN 1 ORIENTATION IN TAPE**



\*All dimensions are nominal

Device	Package Type	Package Drawing	Pins	SPQ	Reel Diameter (mm)	Reel Width W1 (mm)	A0 (mm)	B0 (mm)	K0 (mm)	P1 (mm)	W (mm)	Pin1 Quadrant
SN74BCT652DWR	SOIC	DW	24	2000	330.0	24.4	10.75	15.7	2.7	12.0	24.0	Q1

**TAPE AND REEL BOX DIMENSIONS**



\*All dimensions are nominal

Device	Package Type	Package Drawing	Pins	SPQ	Length (mm)	Width (mm)	Height (mm)
SN74BCT652DWR	SOIC	DW	24	2000	346.0	346.0	41.0

FK (S-CQCC-N\*\*)

LEADLESS CERAMIC CHIP CARRIER

28 TERMINAL SHOWN



4040140/D 10/96

- NOTES:
- A. All linear dimensions are in inches (millimeters).
  - B. This drawing is subject to change without notice.
  - C. This package can be hermetically sealed with a metal lid.
  - D. The terminals are gold plated.
  - E. Falls within JEDEC MS-004

NT (R-PDIP-T\*\*)

PLASTIC DUAL-IN-LINE PACKAGE

24 PINS SHOWN

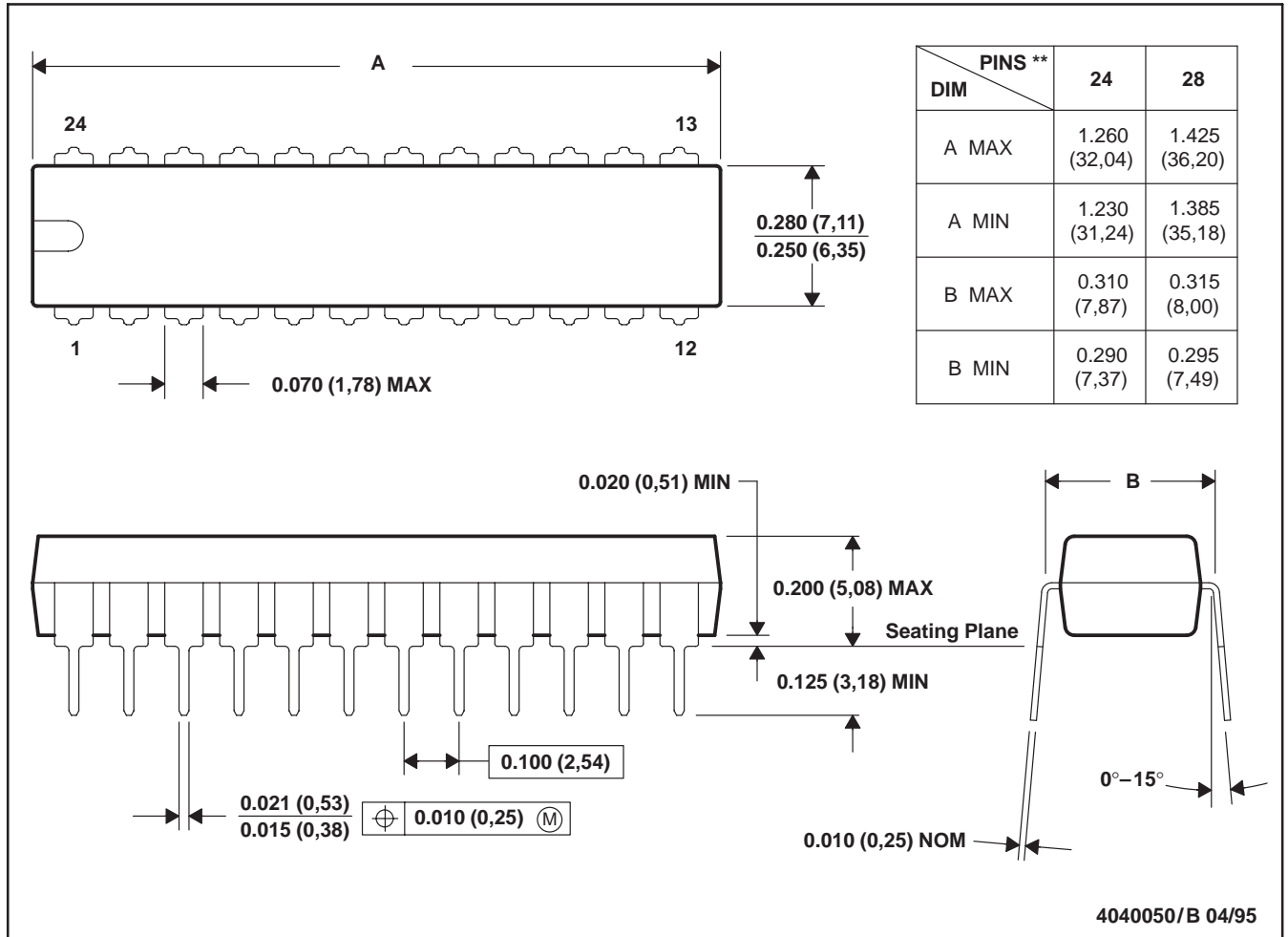

NOTES: A. All linear dimensions are in inches (millimeters).  
 B. This drawing is subject to change without notice.

DW (R-PDSO-G24)

PLASTIC SMALL-OUTLINE PACKAGE

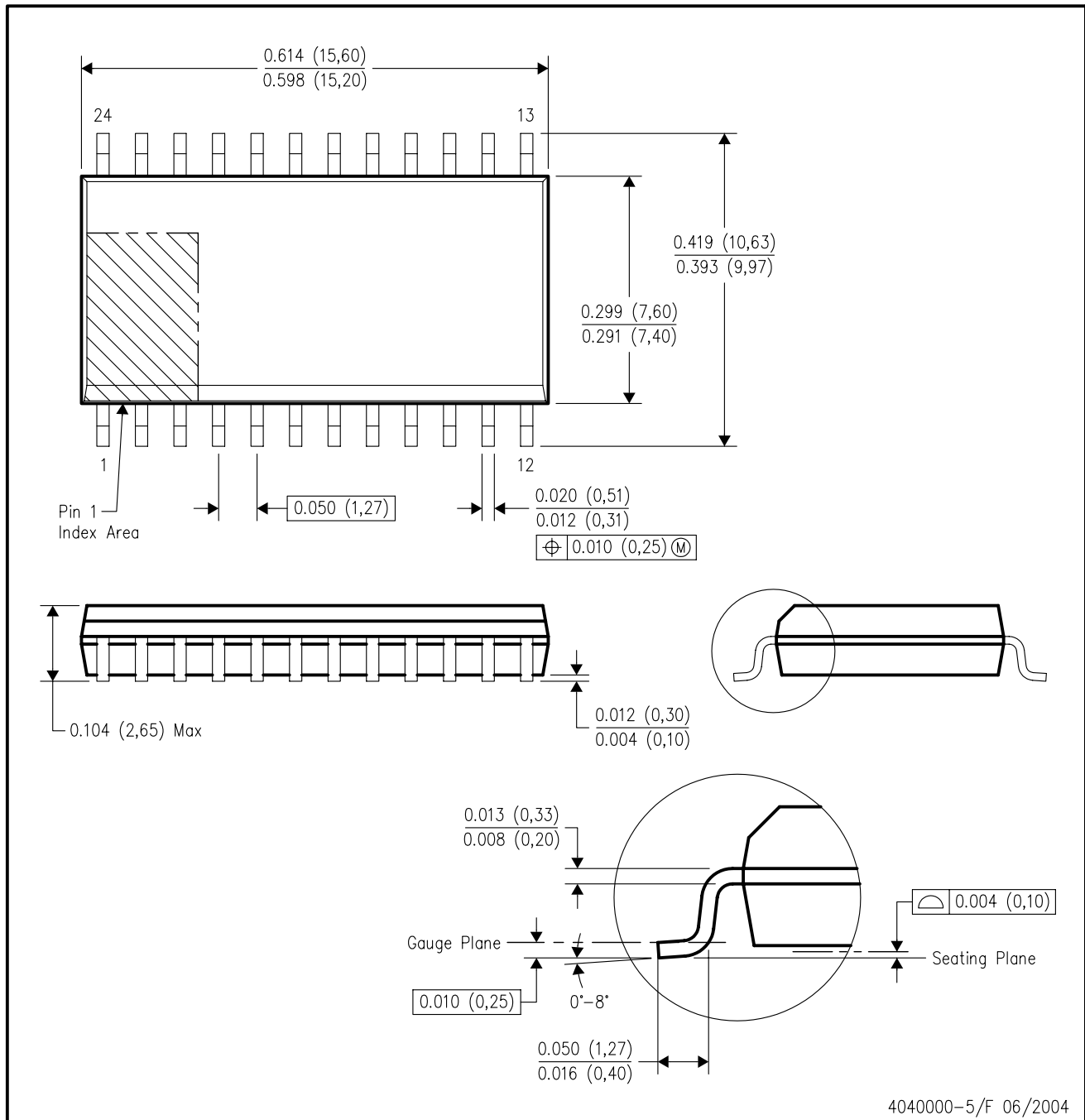

- NOTES:
- A. All linear dimensions are in inches (millimeters).
  - B. This drawing is subject to change without notice.
  - C. Body dimensions do not include mold flash or protrusion not to exceed 0.006 (0,15).
  - D. Falls within JEDEC MS-013 variation AD.

W (R-GDFP-F24)

CERAMIC DUAL FLATPACK

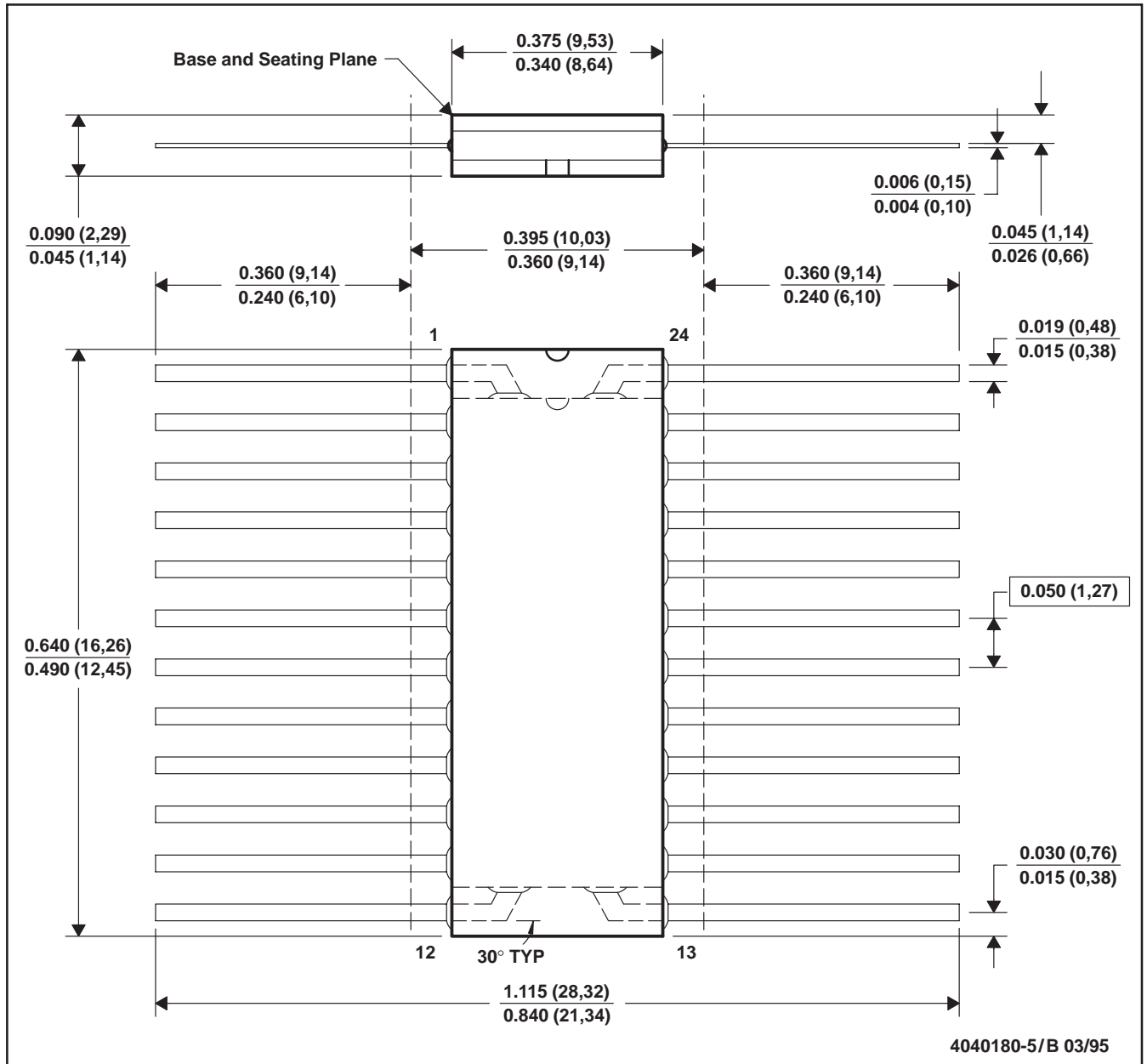

- NOTES: A. All linear dimensions are in inches (millimeters).  
 B. This drawing is subject to change without notice.  
 C. This package can be hermetically sealed with a ceramic lid using glass frit.  
 D. Falls within MIL-STD-1835 GDFP2-F24 and JEDEC MO-070AD  
 E. Index point is provided on cap for terminal identification only.

JT (R-GDIP-T\*\*)

CERAMIC DUAL-IN-LINE

24 LEADS SHOWN

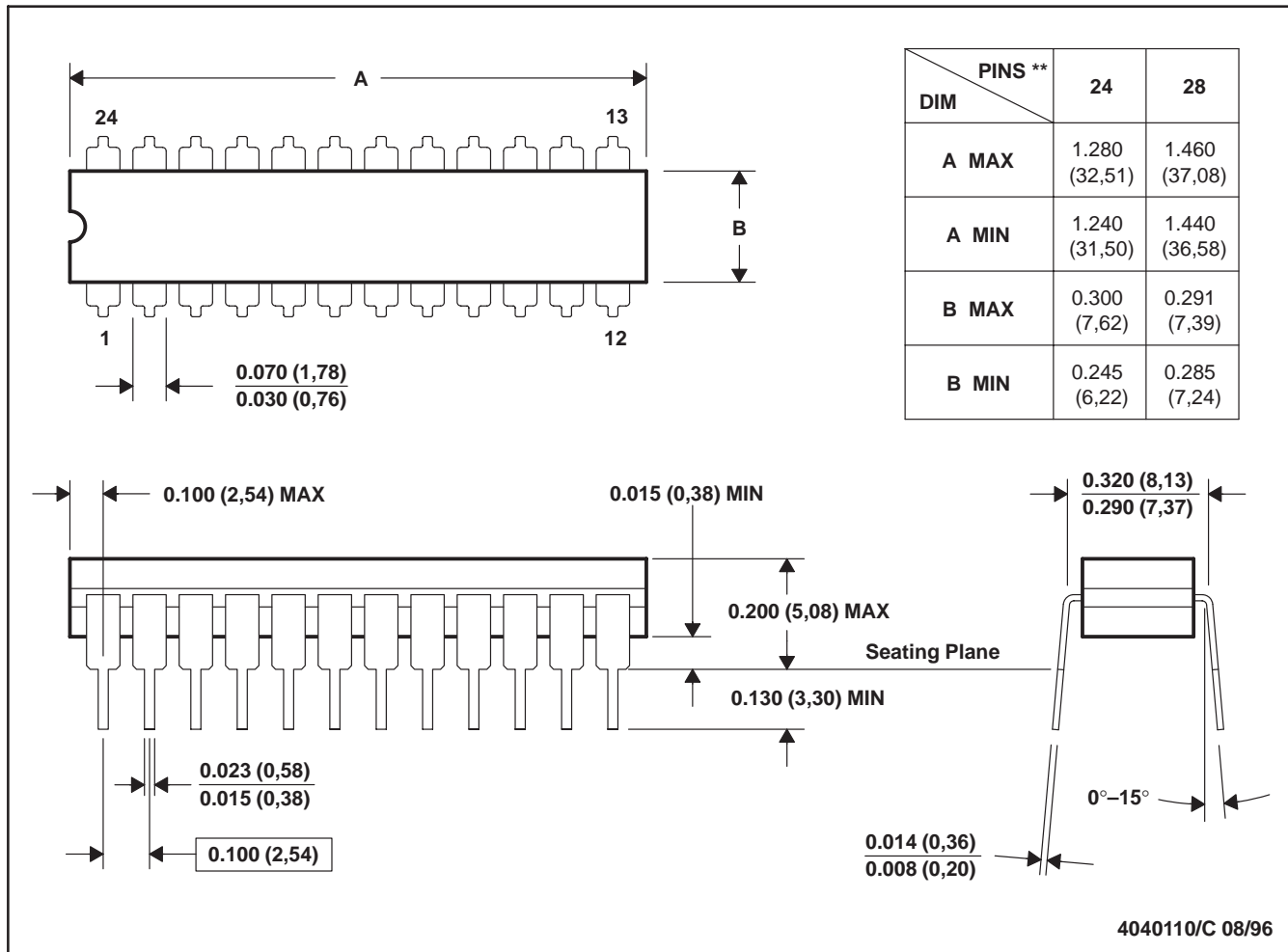

- NOTES: A. All linear dimensions are in inches (millimeters).  
 B. This drawing is subject to change without notice.  
 C. This package can be hermetically sealed with a ceramic lid using glass frit.  
 D. Index point is provided on cap for terminal identification.  
 E. Falls within MIL STD 1835 GDIP3-T24, GDIP4-T28, and JEDEC MO-058 AA, MO-058 AB

## IMPORTANT NOTICE

Texas Instruments Incorporated and its subsidiaries (TI) reserve the right to make corrections, modifications, enhancements, improvements, and other changes to its products and services at any time and to discontinue any product or service without notice. Customers should obtain the latest relevant information before placing orders and should verify that such information is current and complete. All products are sold subject to TI's terms and conditions of sale supplied at the time of order acknowledgment.

TI warrants performance of its hardware products to the specifications applicable at the time of sale in accordance with TI's standard warranty. Testing and other quality control techniques are used to the extent TI deems necessary to support this warranty. Except where mandated by government requirements, testing of all parameters of each product is not necessarily performed.

TI assumes no liability for applications assistance or customer product design. Customers are responsible for their products and applications using TI components. To minimize the risks associated with customer products and applications, customers should provide adequate design and operating safeguards.

TI does not warrant or represent that any license, either express or implied, is granted under any TI patent right, copyright, mask work right, or other TI intellectual property right relating to any combination, machine, or process in which TI products or services are used. Information published by TI regarding third-party products or services does not constitute a license from TI to use such products or services or a warranty or endorsement thereof. Use of such information may require a license from a third party under the patents or other intellectual property of the third party, or a license from TI under the patents or other intellectual property of TI.

Reproduction of TI information in TI data books or data sheets is permissible only if reproduction is without alteration and is accompanied by all associated warranties, conditions, limitations, and notices. Reproduction of this information with alteration is an unfair and deceptive business practice. TI is not responsible or liable for such altered documentation. Information of third parties may be subject to additional restrictions.

Resale of TI products or services with statements different from or beyond the parameters stated by TI for that product or service voids all express and any implied warranties for the associated TI product or service and is an unfair and deceptive business practice. TI is not responsible or liable for any such statements.

TI products are not authorized for use in safety-critical applications (such as life support) where a failure of the TI product would reasonably be expected to cause severe personal injury or death, unless officers of the parties have executed an agreement specifically governing such use. Buyers represent that they have all necessary expertise in the safety and regulatory ramifications of their applications, and acknowledge and agree that they are solely responsible for all legal, regulatory and safety-related requirements concerning their products and any use of TI products in such safety-critical applications, notwithstanding any applications-related information or support that may be provided by TI. Further, Buyers must fully indemnify TI and its representatives against any damages arising out of the use of TI products in such safety-critical applications.

TI products are neither designed nor intended for use in military/aerospace applications or environments unless the TI products are specifically designated by TI as military-grade or "enhanced plastic." Only products designated by TI as military-grade meet military specifications. Buyers acknowledge and agree that any such use of TI products which TI has not designated as military-grade is solely at the Buyer's risk, and that they are solely responsible for compliance with all legal and regulatory requirements in connection with such use.

TI products are neither designed nor intended for use in automotive applications or environments unless the specific TI products are designated by TI as compliant with ISO/TS 16949 requirements. Buyers acknowledge and agree that, if they use any non-designated products in automotive applications, TI will not be responsible for any failure to meet such requirements.

Following are URLs where you can obtain information on other Texas Instruments products and application solutions:

### Products

Amplifiers	<a href="http://amplifier.ti.com">amplifier.ti.com</a>
Data Converters	<a href="http://dataconverter.ti.com">dataconverter.ti.com</a>
DSP	<a href="http://dsp.ti.com">dsp.ti.com</a>
Clocks and Timers	<a href="http://www.ti.com/clocks">www.ti.com/clocks</a>
Interface	<a href="http://interface.ti.com">interface.ti.com</a>
Logic	<a href="http://logic.ti.com">logic.ti.com</a>
Power Mgmt	<a href="http://power.ti.com">power.ti.com</a>
Microcontrollers	<a href="http://microcontroller.ti.com">microcontroller.ti.com</a>
RFID	<a href="http://www.ti-rfid.com">www.ti-rfid.com</a>
RF/IF and ZigBee® Solutions	<a href="http://www.ti.com/lprf">www.ti.com/lprf</a>

### Applications

Audio	<a href="http://www.ti.com/audio">www.ti.com/audio</a>
Automotive	<a href="http://www.ti.com/automotive">www.ti.com/automotive</a>
Broadband	<a href="http://www.ti.com/broadband">www.ti.com/broadband</a>
Digital Control	<a href="http://www.ti.com/digitalcontrol">www.ti.com/digitalcontrol</a>
Medical	<a href="http://www.ti.com/medical">www.ti.com/medical</a>
Military	<a href="http://www.ti.com/military">www.ti.com/military</a>
Optical Networking	<a href="http://www.ti.com/opticalnetwork">www.ti.com/opticalnetwork</a>
Security	<a href="http://www.ti.com/security">www.ti.com/security</a>
Telephony	<a href="http://www.ti.com/telephony">www.ti.com/telephony</a>
Video & Imaging	<a href="http://www.ti.com/video">www.ti.com/video</a>
Wireless	<a href="http://www.ti.com/wireless">www.ti.com/wireless</a>

Mailing Address: Texas Instruments, Post Office Box 655303, Dallas, Texas 75265  
Copyright © 2008, Texas Instruments Incorporated