

SN54BCT29863B, SN74BCT29863B 9-BIT BUS TRANSCEIVERS WITH 3-STATE OUTPUTS

SCBS015D – NOVEMBER 1988 – REVISED NOVEMBER 1993

- BiCMOS Design Substantially Reduces I_{CCZ}
- Functionally Equivalent to 'ALS29863 and AMD Am29863A
- Power-Up High-Impedance State
- ESD Protection Exceeds 2000 V Per MIL-STD-883C, Method 3015
- Package Options Include Plastic Small-Outline Packages (DW), Ceramic Chip Carriers (FK) and Flatpacks (W), and Standard Plastic and Ceramic 300-mil DIPs (JT, NT)

description

These 9-bit transceivers are designed for asynchronous communication between data buses. The control-function implementation allows for maximum flexibility in timing.

These devices allow data transmission from the A bus to the B bus or from the B bus to the A bus, depending upon the logic levels at the output-enable (\overline{OEBA} and \overline{OEAB}) inputs.

The outputs are in the high-impedance state during power-up and power-down conditions. The outputs remain in the high-impedance state while the device is powered down.

The SN54BCT29863B is characterized for operation over the full military temperature range of -55°C to 125°C . The SN74BCT29863B is characterized for operation from 0°C to 70°C .

SN54BCT29863B . . . JT OR W PACKAGE
SN74BCT29863B . . . DW OR NT PACKAGE
(TOP VIEW)

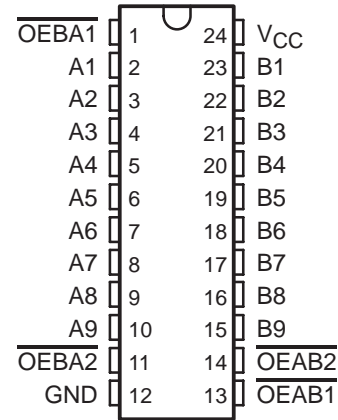

SN54BCT29863B . . . FK PACKAGE
(TOP VIEW)

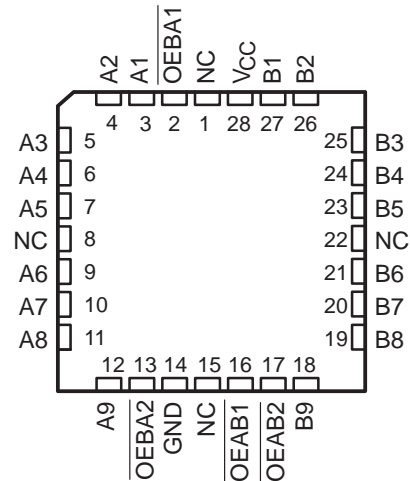

NC – No internal connection

FUNCTION TABLE

INPUTS				OPERATION
$\overline{OEAB1}$	$\overline{OEAB2}$	$\overline{OEBA1}$	$\overline{OEBA2}$	
L	L	L	L	Latch A and B
L	L	H	X	A to B
L	L	X	H	B to A
H	X	L	L	Isolation
X	H	L	L	
H	X	X	H	
X	H	X	H	
X	H	H	X	

PRODUCTION DATA information is current as of publication date. Products conform to specifications per the terms of Texas Instruments standard warranty. Production processing does not necessarily include testing of all parameters.



Copyright © 1993, Texas Instruments Incorporated

SN54BCT29863B, SN74BCT29863B

9-BIT BUS TRANSCEIVERS

WITH 3-STATE OUTPUTS

SCBS015D – NOVEMBER 1988 – REVISED NOVEMBER 1993

logic symbol†

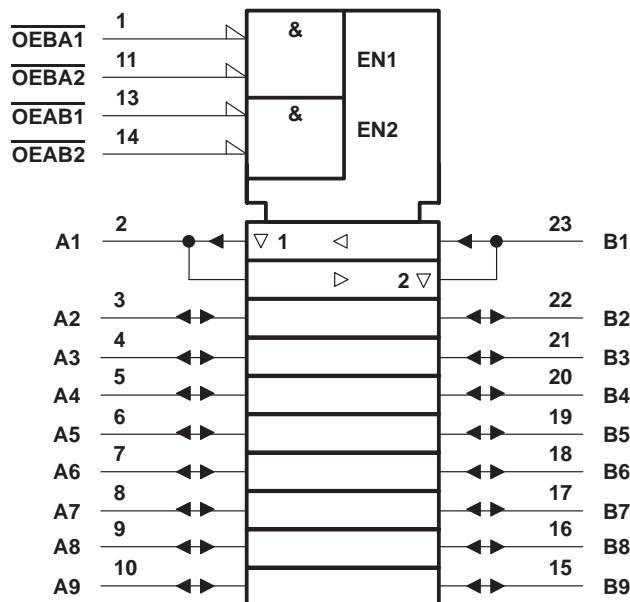

logic diagram (positive logic)

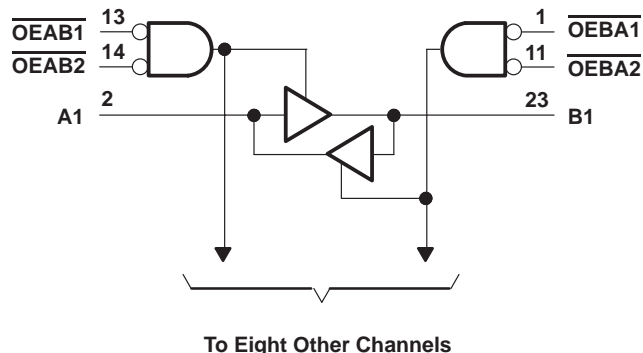

† This symbol is in accordance with ANSI/IEEE Std 91-1984 and IEC Publication 617-12.

Pin numbers shown are for the DW, JT, NT, and W packages.

absolute maximum ratings over operating free-air temperature range (unless otherwise noted)‡

Supply voltage range, V_{CC}	-0.5 V to 7 V
Input voltage range (I/O ports) (see Note 1)	-0.5 V to 5.5 V
Input voltage range (excluding I/O ports) (see Note 1)	-0.5 V to 7 V
Voltage range applied to any output in the high state	-0.5 V to V_{CC}
Input clamp current	-30 mA
Current into any output in the low state: SN54BCT29863B	48 mA
SN74BCT29863B	96 mA
Operating free-air temperature range: SN54BCT29863B	-55°C to 125°C
SN74BCT29863B	0°C to 70°C
Storage temperature range	-65°C to 150°C

‡ Stresses beyond those listed under "absolute maximum ratings" may cause permanent damage to the device. These are stress ratings only, and functional operation of the device at these or any other conditions beyond those indicated under "recommended operating conditions" is not implied. Exposure to absolute-maximum-rated conditions for extended periods may affect device reliability.

NOTE 1: The negative input voltage ratings may be exceeded if the input current rating is observed.



SN54BCT29863B, SN74BCT29863B 9-BIT BUS TRANSCEIVERS WITH 3-STATE OUTPUTS

SCBS015D – NOVEMBER 1988 – REVISED NOVEMBER 1993

recommended operating conditions

		SN54BCT29863B			SN74BCT29863B			UNIT
		MIN	NOM	MAX	MIN	NOM	MAX	
V_{CC}	Supply voltage	4.5	5	5.5	4.5	5	5.5	V
V_{IH}	High-level input voltage	2			2			V
V_{IL}	Low-level input voltage			0.8			0.8	V
I_{IK}	Input clamp current			-18			-18	mA
I_{OH}	High-level output current			-15			-24	mA
I_{OL}	Low-level output current			24			48	mA
T_A	Operating free-air temperature	-55		125	0		70	°C

electrical characteristics over recommended operating free-air temperature range (unless otherwise noted)

PARAMETER	TEST CONDITIONS	SN54BCT29863B			SN74BCT29863B			UNIT
		MIN	TYP†	MAX	MIN	TYP†	MAX	
V_{IK}	$V_{CC} = 4.5\text{ V}$, $I_I = -18\text{ mA}$			-1.2			-1.2	V
V_{OH}	$V_{CC} = 4.5\text{ V}$	$I_{OH} = -15\text{ mA}$		2.4	3.3	2.4	3.3	V
		$I_{OH} = -24\text{ mA}$				2	3.1	
	$V_{CC} = 4.75\text{ V}$, $I_{OH} = -3\text{ mA}$					2.7		
V_{OL}	$V_{CC} = 4.5\text{ V}$	$I_{OL} = 24\text{ mA}$		0.35	0.5			V
		$I_{OL} = 48\text{ mA}$				0.35	0.5	
I_I	$V_{CC} = 5.5\text{ V}$, $V_I = 5.5\text{ V}$			0.1			0.1	mA
I_{IH}	Control inputs	$V_{CC} = 5.5\text{ V}$, $V_I = 2.7\text{ V}$				20		μA
	A or B port‡					20		
I_{IL}	Control inputs	$V_{CC} = 5.5\text{ V}$, $V_I = 0.5\text{ V}$				-0.2		mA
	A or B port‡					-0.2		
$I_{IO(off)}^{\S}$	$V_{CC} = 0$, $V_O = 2.7\text{ V}$			0.1			0.1	mA
I_{OS}^{\parallel}	$V_{CC} = 5.5\text{ V}$, $V_O = 0$	-75		-250	-75		-250	mA
I_{CC}	$V_{CC} = 5.5\text{ V}$	Outputs high		18	30	18	30	mA
		Outputs low		30	45	30	45	
		Outputs disabled		6.5	12	6.5	12	
C_i	$V_{CC} = 5\text{ V}$, $V_I = 2.5\text{ V}$ or 0.5 V	6			6			pF
C_{io}	$V_{CC} = 5\text{ V}$, $V_I = 2.5\text{ V}$ or 0.5 V	8			8			pF

† All typical values are at $V_{CC} = 5\text{ V}$, $T_A = 25^\circ\text{C}$.

‡ For I/O ports, the parameters I_{IH} and I_{IL} include the off-state output current.

§ $I_{O(off)}$ = Power-off bus-leakage current

¶ Not more than one output should be shorted at a time and duration of the short circuit should not exceed one second.



SN54BCT29863B, SN74BCT29863B
9-BIT BUS TRANSCEIVERS
WITH 3-STATE OUTPUTS

SCBS015D – NOVEMBER 1988 – REVISED NOVEMBER 1993

switching characteristics (see Note 2)

PARAMETER	FROM (INPUT)	TO (OUTPUT)	V _{CC} = 5 V, C _L = 50 pF, R1 = 500 Ω, R2 = 500 Ω, T _A = 25°C			V _{CC} = 4.5 V to 5.5 V, C _L = 50 pF, R1 = 500 Ω, R2 = 500 Ω, T _A = MIN to MAX†				UNIT
			'BCT29863B			SN54BCT29863B		SN74BCT29863B		
			MIN	TYP	MAX	MIN	MAX	MIN	MAX	
t _{PLH}	A or B	B or A	1	3	4.5	1	5.4	1	5	ns
t _{PHL}			2	4.8	6.8	2	7.9	2	7.5	
t _{PZH}	$\overline{\text{OEAB}}$ or $\overline{\text{OEBA}}$	A or B	2	5.1	7	2	9.2	2	8.4	ns
t _{PZL}			4.5	8.4	10.8	4.5	13.6	4.5	12.6	
t _{PHZ}	$\overline{\text{OEAB}}$ or $\overline{\text{OEBA}}$	A or B	2	5	7.2	2	9.6	2	8.8	ns
t _{PLZ}			1.7	4.7	6.7	1.7	9.1	1.7	8.1	

† For conditions shown as MIN or MAX, use the appropriate value specified under recommended operating conditions.

NOTE 2: Load circuits and voltage waveforms are shown in Section 1.



IMPORTANT NOTICE

Texas Instruments Incorporated and its subsidiaries (TI) reserve the right to make corrections, modifications, enhancements, improvements, and other changes to its products and services at any time and to discontinue any product or service without notice. Customers should obtain the latest relevant information before placing orders and should verify that such information is current and complete. All products are sold subject to TI's terms and conditions of sale supplied at the time of order acknowledgment.

TI warrants performance of its hardware products to the specifications applicable at the time of sale in accordance with TI's standard warranty. Testing and other quality control techniques are used to the extent TI deems necessary to support this warranty. Except where mandated by government requirements, testing of all parameters of each product is not necessarily performed.

TI assumes no liability for applications assistance or customer product design. Customers are responsible for their products and applications using TI components. To minimize the risks associated with customer products and applications, customers should provide adequate design and operating safeguards.

TI does not warrant or represent that any license, either express or implied, is granted under any TI patent right, copyright, mask work right, or other TI intellectual property right relating to any combination, machine, or process in which TI products or services are used. Information published by TI regarding third-party products or services does not constitute a license from TI to use such products or services or a warranty or endorsement thereof. Use of such information may require a license from a third party under the patents or other intellectual property of the third party, or a license from TI under the patents or other intellectual property of TI.

Reproduction of TI information in TI data books or data sheets is permissible only if reproduction is without alteration and is accompanied by all associated warranties, conditions, limitations, and notices. Reproduction of this information with alteration is an unfair and deceptive business practice. TI is not responsible or liable for such altered documentation. Information of third parties may be subject to additional restrictions.

Resale of TI products or services with statements different from or beyond the parameters stated by TI for that product or service voids all express and any implied warranties for the associated TI product or service and is an unfair and deceptive business practice. TI is not responsible or liable for any such statements.

TI products are not authorized for use in safety-critical applications (such as life support) where a failure of the TI product would reasonably be expected to cause severe personal injury or death, unless officers of the parties have executed an agreement specifically governing such use. Buyers represent that they have all necessary expertise in the safety and regulatory ramifications of their applications, and acknowledge and agree that they are solely responsible for all legal, regulatory and safety-related requirements concerning their products and any use of TI products in such safety-critical applications, notwithstanding any applications-related information or support that may be provided by TI. Further, Buyers must fully indemnify TI and its representatives against any damages arising out of the use of TI products in such safety-critical applications.

TI products are neither designed nor intended for use in military/aerospace applications or environments unless the TI products are specifically designated by TI as military-grade or "enhanced plastic." Only products designated by TI as military-grade meet military specifications. Buyers acknowledge and agree that any such use of TI products which TI has not designated as military-grade is solely at the Buyer's risk, and that they are solely responsible for compliance with all legal and regulatory requirements in connection with such use.

TI products are neither designed nor intended for use in automotive applications or environments unless the specific TI products are designated by TI as compliant with ISO/TS 16949 requirements. Buyers acknowledge and agree that, if they use any non-designated products in automotive applications, TI will not be responsible for any failure to meet such requirements.

Following are URLs where you can obtain information on other Texas Instruments products and application solutions:

Products

Amplifiers	amplifier.ti.com
Data Converters	dataconverter.ti.com
DSP	dsp.ti.com
Clocks and Timers	www.ti.com/clocks
Interface	interface.ti.com
Logic	logic.ti.com
Power Mgmt	power.ti.com
Microcontrollers	microcontroller.ti.com
RFID	www.ti-rfid.com
RF/IF and ZigBee® Solutions	www.ti.com/lprf

Applications

Audio	www.ti.com/audio
Automotive	www.ti.com/automotive
Broadband	www.ti.com/broadband
Digital Control	www.ti.com/digitalcontrol
Medical	www.ti.com/medical
Military	www.ti.com/military
Optical Networking	www.ti.com/opticalnetwork
Security	www.ti.com/security
Telephony	www.ti.com/telephony
Video & Imaging	www.ti.com/video
Wireless	www.ti.com/wireless

Mailing Address: Texas Instruments, Post Office Box 655303, Dallas, Texas 75265
Copyright © 2008, Texas Instruments Incorporated