

SN74AUP1G126 LOW-POWER SINGLE BUS BUFFER GATE WITH 3-STATE OUTPUT

SCES596D – JULY 2004 – REVISED JUNE 2005

- Available in the Texas Instruments NanoStar™ and NanoFree™ Packages
- Low Static-Power Consumption ($I_{CC} = 0.9 \mu\text{A Max}$)
- Low Dynamic-Power Consumption ($C_{pd} = 4 \text{ pF Typ at } 3.3 \text{ V}$)
- Low Input Capacitance ($C_i = 1.5 \text{ pF Typ}$)
- Low Noise – Overshoot and Undershoot <10% of V_{CC}
- Input-Disable Feature Allows Floating Input Conditions
- I_{off} Supports Partial-Power-Down Mode Operation
- Input Hysteresis Allows Slow Input Transition and Better Switching Noise Immunity at Input
- Wide Operating V_{CC} Range of 0.8 V to 3.6 V
- Optimized for 3.3-V Operation
- 3.6-V I/O Tolerant to Support Mixed-Mode Signal Operation
- $t_{pd} = 4.6 \text{ ns Max at } 3.3 \text{ V}$
- Suitable for Point-to-Point Applications
- Latch-Up Performance Exceeds 100 mA Per JESD 78, Class II
- ESD Performance Tested Per JESD 22
 - 2000-V Human-Body Model (A114-B, Class II)
 - 200-V Machine Model (A115-A)
 - 1000-V Charged-Device Model (C101)
- ESD Protection Exceeds $\pm 5000 \text{ V}$ With Human-Body Model

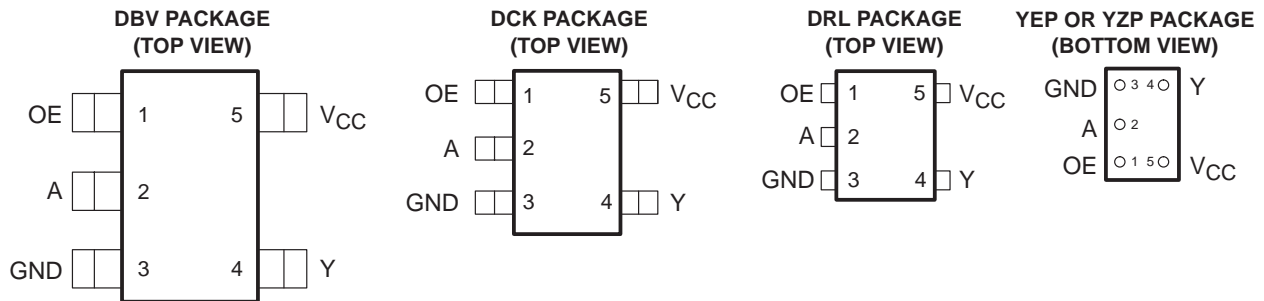

See mechanical drawings for dimensions.

description/ordering information

The AUP family is TI's premier solution to the industry's low-power needs in battery-powered portable applications. This family ensures a very low static and dynamic power consumption across the entire V_{CC} range of 0.8 V to 3.6 V, resulting in an increased battery life. This product also maintains excellent signal integrity (see Figures 1 and 2).

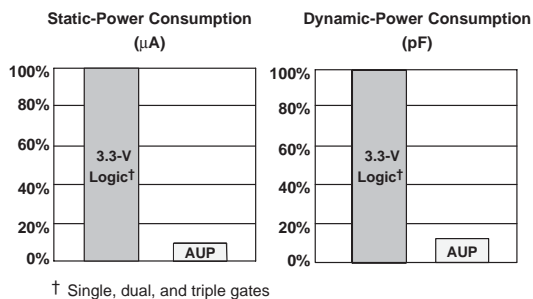

Figure 1. AUP – The Lowest-Power Family

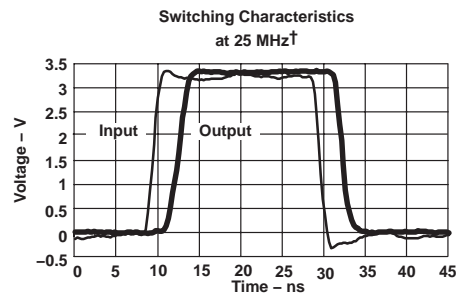

Figure 2. Excellent Signal Integrity



Please be aware that an important notice concerning availability, standard warranty, and use in critical applications of Texas Instruments semiconductor products and disclaimers thereto appears at the end of this data sheet.

NanoStar and NanoFree are trademarks of Texas Instruments.

PRODUCTION DATA information is current as of publication date. Products conform to specifications per the terms of Texas Instruments standard warranty. Production processing does not necessarily include testing of all parameters.



POST OFFICE BOX 655303 • DALLAS, TEXAS 75265

Copyright © 2005, Texas Instruments Incorporated

SN74AUP1G126

LOW-POWER SINGLE BUS BUFFER GATE

WITH 3-STATE OUTPUT

SCES596D – JULY 2004 – REVISED JUNE 2005

description/ordering information (continued)

This bus buffer gate is a single line driver with a 3-state output. The output is disabled when the output-enable (OE) input is low. This device has the input-disable feature, which allows floating input signals.

To ensure the high-impedance state during power up or power down, OE should be tied to GND through a pulldown resistor; the minimum value of the resistor is determined by the current-sourcing capability of the driver.

NanoStar™ and NanoFree™ package technology is a major breakthrough in IC packaging concepts, using the die as the package.

This device is fully specified for partial-power-down applications using I_{off} . The I_{off} circuitry disables the outputs, preventing damaging current backflow through the device when it is powered down.

ORDERING INFORMATION

TA	PACKAGE†		ORDERABLE PART NUMBER	TOP-SIDE MARKING‡
-40°C to 85°C	NanoStar™ – WCSP (DSBGA) 0.23-mm Large Bump – YEP	Tape and reel	SN74AUP1G126YEPR	___HN_
	NanoFree™ – WCSP (DSBGA) 0.23-mm Large Bump – YZP (Pb-free)	Tape and reel	SN74AUP1G126YZPR	
	SOT (SOT-23) – DBV	Tape and reel	SN74AUP1G126DBVR	H26_
	SOT (SC-70) – DCK	Tape and reel	SN74AUP1G126DCKR	HN_
	SOT (SOT-553) – DRL	Reel of 4000	SN74AUP1G126DRLR	

† Package drawings, standard packing quantities, thermal data, symbolization, and PCB design guidelines are available at www.ti.com/sc/package.

‡ DBV/DCK/DRL: The actual top-side marking has one additional character that designates the assembly/test site.

YEP/YZP: The actual top-side marking has three preceding characters to denote year, month, and sequence code, and one following character to designate the assembly/test site. Pin 1 identifier indicates solder-bump composition (1 = SnPb, • = Pb-free).

FUNCTION TABLE

INPUTS		OUTPUT
OE	A	Y
H	H	H
H	L	L
L	X§	Z

§ Floating inputs allowed.

logic diagram (positive logic)

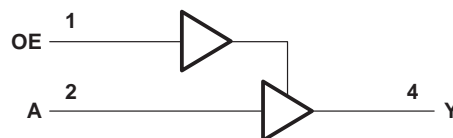

SN74AUP1G126
LOW-POWER SINGLE BUS BUFFER GATE
WITH 3-STATE OUTPUT

SCES596D – JULY 2004 – REVISED JUNE 2005

recommended operating conditions (see Note 3)

		MIN	MAX	UNIT	
V_{CC}	Supply voltage	0.8	3.6	V	
V_{IH}	High-level input voltage	$V_{CC} = 0.8\text{ V}$	V_{CC}	3.6	V
		$V_{CC} = 1.1\text{ V to }1.95\text{ V}$	$0.65 \times V_{CC}$	3.6	
		$V_{CC} = 2.3\text{ V to }2.7\text{ V}$	1.6	3.6	
		$V_{CC} = 3\text{ V to }3.6\text{ V}$	2	3.6	
V_{IL}	Low-level input voltage	$V_{CC} = 0.8\text{ V}$	0	0	V
		$V_{CC} = 1.1\text{ V to }1.95\text{ V}$	0	$0.35 \times V_{CC}$	
		$V_{CC} = 2.3\text{ V to }2.7\text{ V}$	0	0.7	
		$V_{CC} = 3\text{ V to }3.6\text{ V}$	0	0.9	
V_O	Output voltage	Active state	0	V_{CC}	V
		3-state	0	3.6	
I_{OH}	High-level output current	$V_{CC} = 0.8\text{ V}$		-20	μA
		$V_{CC} = 1.1\text{ V}$		-1.1	mA
		$V_{CC} = 1.4\text{ V}$		-1.7	
		$V_{CC} = 1.65$		-1.9	
		$V_{CC} = 2.3\text{ V}$		-3.1	
		$V_{CC} = 3\text{ V}$		-4	
I_{OL}	Low-level output current	$V_{CC} = 0.8\text{ V}$		20	μA
		$V_{CC} = 1.1\text{ V}$		1.1	mA
		$V_{CC} = 1.4\text{ V}$		1.7	
		$V_{CC} = 1.65\text{ V}$		1.9	
		$V_{CC} = 2.3\text{ V}$		3.1	
		$V_{CC} = 3\text{ V}$		4	
$\Delta t/\Delta v$	Input transition rise or fall rate	$V_{CC} = 0.8\text{ V to }3.6\text{ V}$		200	ns/V
T_A	Operating free-air temperature		-40	85	$^{\circ}\text{C}$

NOTE 3: All unused inputs of the device must be held at V_{CC} or GND to ensure proper device operation. Refer to the TI application report, *Implications of Slow or Floating CMOS Inputs*, literature number SCBA004.



SN74AUP1G126
LOW-POWER SINGLE BUS BUFFER GATE
WITH 3-STATE OUTPUT

SCES596D – JULY 2004 – REVISED JUNE 2005

electrical characteristics over recommended operating free-air temperature range (unless otherwise noted)

PARAMETER	TEST CONDITIONS	V _{CC}	T _A = 25°C			T _A = -40°C TO 85°C		UNIT
			MIN	TYP	MAX	MIN	MAX	
V _{OH}	I _{OH} = -20 μA	0.8 V to 3.6 V	V _{CC} - 0.1			V _{CC} - 0.1		V
	I _{OH} = -1.1 mA	1.1 V	0.75 × V _{CC}			0.7 × V _{CC}		
	I _{OH} = -1.7 mA	1.4 V	1.11			1.03		
	I _{OH} = -1.9 mA	1.65 V	1.32			1.3		
	I _{OH} = -2.3 mA	2.3 V	2.05			1.97		
	I _{OH} = -3.1 mA		1.9			1.85		
	I _{OH} = -2.7 mA	3 V	2.72			2.67		
	I _{OH} = -4 mA		2.6			2.55		
V _{OL}	I _{OL} = 20 μA	0.8 V to 3.6 V	0.1			0.1		V
	I _{OL} = 1.1 mA	1.1 V	0.3 × V _{CC}			0.3 × V _{CC}		
	I _{OL} = 1.7 mA	1.4 V	0.31			0.37		
	I _{OL} = 1.9 mA	1.65 V	0.31			0.35		
	I _{OL} = 2.3 mA	2.3 V	0.31			0.33		
	I _{OL} = 3.1 mA		0.44			0.45		
	I _{OL} = 2.7 mA	3 V	0.31			0.33		
	I _{OL} = 4 mA		0.44			0.45		
I _I	A or OE input	V _I = GND to 3.6 V	0 V to 3.6 V			0.1	0.5	μA
I _{off}		V _I or V _O = 0 V to 3.6 V	0 V			0.2	0.6	μA
ΔI _{off}		V _I or V _O = 0 V to 3.6 V	0 V to 0.2 V			0.2	0.6	μA
I _{OZ}		V _O = V _{CC} or GND	3.6 V				0.5	μA
I _{CC}		V _I = GND or (V _{CC} to 3.6 V), OE = V _{CC} ; I _O = 0	0.8 V to 3.6 V			0.5	0.9	μA
ΔI _{CC}	A input	V _I = V _{CC} - 0.6 V [†] , I _O = 0	3.3 V			40	50	μA
	OE input					110	120	
	All inputs	V _I = GND to 3.6 V, OE = GND [‡]	0.8 V to 3.6 V			0	0	
C _i	V _I = V _{CC} or GND	0 V	1.5					pF
		3.6 V	1.5					
C _o	V _O = V _{CC} or GND	3.6 V	3					pF

[†] One input at V_{CC} - 0.6 V, other input at V_{CC} or GND

[‡] To show I_{CC} is very low when the input-disable feature is enabled



SN74AUP1G126
LOW-POWER SINGLE BUS BUFFER GATE
WITH 3-STATE OUTPUT

SCES596D – JULY 2004 – REVISED JUNE 2005

switching characteristics over recommended operating free-air temperature range, $C_L = 5 \text{ pF}$
(unless otherwise noted) (see Figures 3 and 4)

PARAMETER	FROM (INPUT)	TO (OUTPUT)	V_{CC}	$T_A = 25^\circ\text{C}$			$T_A = -40^\circ\text{C}$ TO 85°C		UNIT
				MIN	TYP	MAX	MIN	MAX	
t_{pd}	A	Y	0.8 V	18.1					ns
			$1.2 \text{ V} \pm 0.1 \text{ V}$	4.3	7.4	12.6	2.7	15.3	
			$1.5 \text{ V} \pm 0.1 \text{ V}$	3.3	5.2	8.5	1	10.2	
			$1.8 \text{ V} \pm 0.15 \text{ V}$	2.6	4.1	6.8	1.3	8.3	
			$2.5 \text{ V} \pm 0.2 \text{ V}$	2	2.9	4.7	1.1	5.8	
			$3.3 \text{ V} \pm 0.3 \text{ V}$	1.7	2.4	3.8	1	4.6	
t_{en}	OE	Y	0.8 V	19.1					ns
			$1.2 \text{ V} \pm 0.1 \text{ V}$	5.1	9.3	15.9	3.6	19.2	
			$1.5 \text{ V} \pm 0.1 \text{ V}$	4.1	6.6	10.5	2.5	12.7	
			$1.8 \text{ V} \pm 0.15 \text{ V}$	3.2	5.3	8.7	2.1	10.3	
			$2.5 \text{ V} \pm 0.2 \text{ V}$	2.5	3.8	6	1.6	7.2	
			$3.3 \text{ V} \pm 0.3 \text{ V}$	2.1	3.2	4.9	1.4	5.9	
t_{dis}	OE	Y	0.8 V	12.1					ns
			$1.2 \text{ V} \pm 0.1 \text{ V}$	2.4	4.1	6.9	2.2	7.7	
			$1.5 \text{ V} \pm 0.1 \text{ V}$	1.8	2.9	4.5	1.7	5.1	
			$1.8 \text{ V} \pm 0.15 \text{ V}$	1	2.9	4.3	1.5	4.7	
			$2.5 \text{ V} \pm 0.2 \text{ V}$	1	1.8	2.7	1	3.3	
			$3.3 \text{ V} \pm 0.3 \text{ V}$	1.2	2.2	3.2	1.1	4	



SN74AUP1G126
LOW-POWER SINGLE BUS BUFFER GATE
WITH 3-STATE OUTPUT

SCES596D – JULY 2004 – REVISED JUNE 2005

switching characteristics over recommended operating free-air temperature range, $C_L = 10 \text{ pF}$
(unless otherwise noted) (see Figures 3 and 4)

PARAMETER	FROM (INPUT)	TO (OUTPUT)	V_{CC}	$T_A = 25^\circ\text{C}$			$T_A = -40^\circ\text{C}$ TO 85°C		UNIT
				MIN	TYP	MAX	MIN	MAX	
t_{pd}	A or B	Y	0.8 V	20.5					ns
			$1.2 \text{ V} \pm 0.1 \text{ V}$	4.6	8.4	13.7	3.6	16.6	
			$1.5 \text{ V} \pm 0.1 \text{ V}$	3.5	5.9	9.3	2.4	11.1	
			$1.8 \text{ V} \pm 0.15 \text{ V}$	3.9	4.7	7.5	1.3	9.1	
			$2.5 \text{ V} \pm 0.2 \text{ V}$	2.3	3.4	5.3	1.6	6.4	
			$3.3 \text{ V} \pm 0.3 \text{ V}$	2.1	2.8	4.3	1.4	5.2	
t_{en}	OE	Y	0.8 V	21.8					ns
			$1.2 \text{ V} \pm 0.1 \text{ V}$	4.9	10.2	16.8	4.4	20.2	
			$1.5 \text{ V} \pm 0.1 \text{ V}$	3.9	7.3	11.2	3.3	13.5	
			$1.8 \text{ V} \pm 0.15 \text{ V}$	3.4	5.8	9.2	2.7	11	
			$2.5 \text{ V} \pm 0.2 \text{ V}$	2.5	4.3	6.4	2.1	7.8	
			$3.3 \text{ V} \pm 0.3 \text{ V}$	2.1	3.7	5.4	1.9	6.4	
t_{dis}	OE	Y	0.8 V	13					ns
			$1.2 \text{ V} \pm 0.1 \text{ V}$	3.8	6.6	11.7	1.2	14	
			$1.5 \text{ V} \pm 0.1 \text{ V}$	2.2	4.7	7.9	1.3	9.3	
			$1.8 \text{ V} \pm 0.15 \text{ V}$	2.4	4.4	6.4	2.2	7.5	
			$2.5 \text{ V} \pm 0.2 \text{ V}$	1.3	3.1	4.9	1.2	5.4	
			$3.3 \text{ V} \pm 0.3 \text{ V}$	1.9	3.4	5	1.9	5.6	

SN74AUP1G126
LOW-POWER SINGLE BUS BUFFER GATE
WITH 3-STATE OUTPUT

SCES596D – JULY 2004 – REVISED JUNE 2005

switching characteristics over recommended operating free-air temperature range, $C_L = 15 \text{ pF}$
(unless otherwise noted) (see Figures 3 and 4)

PARAMETER	FROM (INPUT)	TO (OUTPUT)	V_{CC}	$T_A = 25^\circ\text{C}$			$T_A = -40^\circ\text{C}$ TO 85°C		UNIT
				MIN	TYP	MAX	MIN	MAX	
t_{pd}	A or B	Y	0.8 V	22.5					ns
			$1.2 \text{ V} \pm 0.1 \text{ V}$	5.8	9.3	15.1	4.3	17.9	
			$1.5 \text{ V} \pm 0.1 \text{ V}$	4.4	6.6	10.2	3	12.1	
			$1.8 \text{ V} \pm 0.15 \text{ V}$	3.5	5.3	8.3	2.3	9.9	
			$2.5 \text{ V} \pm 0.2 \text{ V}$	2.7	3.9	5.8	1.9	7	
			$3.3 \text{ V} \pm 0.3 \text{ V}$	2.4	3.2	4.7	1.8	5.7	
t_{en}	OE	Y	0.8 V	25.2					ns
			$1.2 \text{ V} \pm 0.1 \text{ V}$	7	11.3	18.1	5.4	21.4	
			$1.5 \text{ V} \pm 0.1 \text{ V}$	5.5	8.1	12.2	4.1	14.5	
			$1.8 \text{ V} \pm 0.15 \text{ V}$	4.3	6.5	10.1	3.3	12	
			$2.5 \text{ V} \pm 0.2 \text{ V}$	3.4	4.8	7.1	2.6	8.4	
			$3.3 \text{ V} \pm 0.3 \text{ V}$	2.9	4.1	5.9	2.3	6.9	
t_{dis}	OE	Y	0.8 V	14					ns
			$1.2 \text{ V} \pm 0.1 \text{ V}$	3.7	5.8	8.2	3.3	11	
			$1.5 \text{ V} \pm 0.1 \text{ V}$	5.5	3.9	5.9	2.1	8	
			$1.8 \text{ V} \pm 0.15 \text{ V}$	3.3	4.5	6.6	2.9	7.4	
			$2.5 \text{ V} \pm 0.2 \text{ V}$	2.3	3.2	4.3	1.8	5.1	
			$3.3 \text{ V} \pm 0.3 \text{ V}$	2.4	4.8	6.2	3.1	6.7	

SN74AUP1G126
LOW-POWER SINGLE BUS BUFFER GATE
WITH 3-STATE OUTPUT

SCES596D – JULY 2004 – REVISED JUNE 2005

switching characteristics over recommended operating free-air temperature range, $C_L = 30$ pF (unless otherwise noted) (see Figures 3 and 4)

PARAMETER	FROM (INPUT)	TO (OUTPUT)	V_{CC}	$T_A = 25^\circ\text{C}$			$T_A = -40^\circ\text{C}$ TO 85°C		UNIT
				MIN	TYP	MAX	MIN	MAX	
t_{pd}	A or B	Y	0.8 V	29					ns
			$1.2\text{ V} \pm 0.1\text{ V}$	7.4	12	18.7	6.6	21.4	
			$1.5\text{ V} \pm 0.1\text{ V}$	5.7	8.6	12.5	4.9	14.7	
			$1.8\text{ V} \pm 0.15\text{ V}$	4.8	6.9	10.1	3.1	12	
			$2.5\text{ V} \pm 0.2\text{ V}$	3.9	5.1	7.2	3.3	8.7	
			$3.3\text{ V} \pm 0.3\text{ V}$	3.5	4.8	6	3	7	
t_{en}	OE	Y	0.8 V	33.4					ns
			$1.2\text{ V} \pm 0.1\text{ V}$	8.8	14.1	21.8	7.4	25.5	
			$1.5\text{ V} \pm 0.1\text{ V}$	6.9	10.1	14.6	5.6	17.4	
			$1.8\text{ V} \pm 0.15\text{ V}$	5.6	8.1	12	4.7	14.1	
			$2.5\text{ V} \pm 0.2\text{ V}$	4.3	6.1	8.5	3.8	10	
			$3.3\text{ V} \pm 0.3\text{ V}$	3.7	5.2	7.1	3.4	8.3	
t_{dis}	OE	Y	0.8 V	17.7					ns
			$1.2\text{ V} \pm 0.1\text{ V}$	5.8	10	16	3.7	16	
			$1.5\text{ V} \pm 0.1\text{ V}$	5.7	7.7	10.9	1	10.7	
			$1.8\text{ V} \pm 0.15\text{ V}$	4.5	7.7	9.8	4.4	12.5	
			$2.5\text{ V} \pm 0.2\text{ V}$	3.9	5.6	7.4	3.2	9	
			$3.3\text{ V} \pm 0.3\text{ V}$	3.3	8.4	10.7	6.6	10.8	

operating characteristics, $T_A = 25^\circ\text{C}$

PARAMETER		TEST CONDITIONS	V_{CC}	TYP	UNIT	
C_{pd}	Power dissipation capacitance	Outputs enabled	$f = 10\text{ MHz}$	0.8 V	3.8	pF
				$1.2\text{ V} \pm 0.1\text{ V}$	3.7	
				$1.5\text{ V} \pm 0.1\text{ V}$	3.7	
				$1.8\text{ V} \pm 0.15\text{ V}$	3.7	
				$2.5\text{ V} \pm 0.2\text{ V}$	3.9	
				$3.3\text{ V} \pm 0.3\text{ V}$	4	
	Outputs disabled	$f = 10\text{ MHz}$	0.8 V	0		
			$1.2\text{ V} \pm 0.1\text{ V}$	0		
			$1.5\text{ V} \pm 0.1\text{ V}$	0		
			$1.8\text{ V} \pm 0.15\text{ V}$	0		
			$2.5\text{ V} \pm 0.2\text{ V}$	0		
			$3.3\text{ V} \pm 0.3\text{ V}$	0		



SN74AUP1G126
LOW-POWER SINGLE BUS BUFFER GATE
WITH 3-STATE OUTPUT

SCES596D – JULY 2004 – REVISED JUNE 2005

PARAMETER MEASUREMENT INFORMATION
(Propagation Delays, Setup and Hold Times, and Pulse Width)

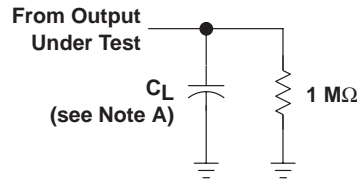

LOAD CIRCUIT

	$V_{CC} = 0.8\text{ V}$	$V_{CC} = 1.2\text{ V}$ $\pm 0.1\text{ V}$	$V_{CC} = 1.5\text{ V}$ $\pm 0.1\text{ V}$	$V_{CC} = 1.8\text{ V}$ $\pm 0.15\text{ V}$	$V_{CC} = 2.5\text{ V}$ $\pm 0.2\text{ V}$	$V_{CC} = 3.3\text{ V}$ $\pm 0.3\text{ V}$
C_L	5, 10, 15, 30 pF	5, 10, 15, 30 pF	5, 10, 15, 30 pF	5, 10, 15, 30 pF	5, 10, 15, 30 pF	5, 10, 15, 30 pF
V_M	$V_{CC}/2$	$V_{CC}/2$	$V_{CC}/2$	$V_{CC}/2$	$V_{CC}/2$	$V_{CC}/2$
V_I	V_{CC}	V_{CC}	V_{CC}	V_{CC}	V_{CC}	V_{CC}

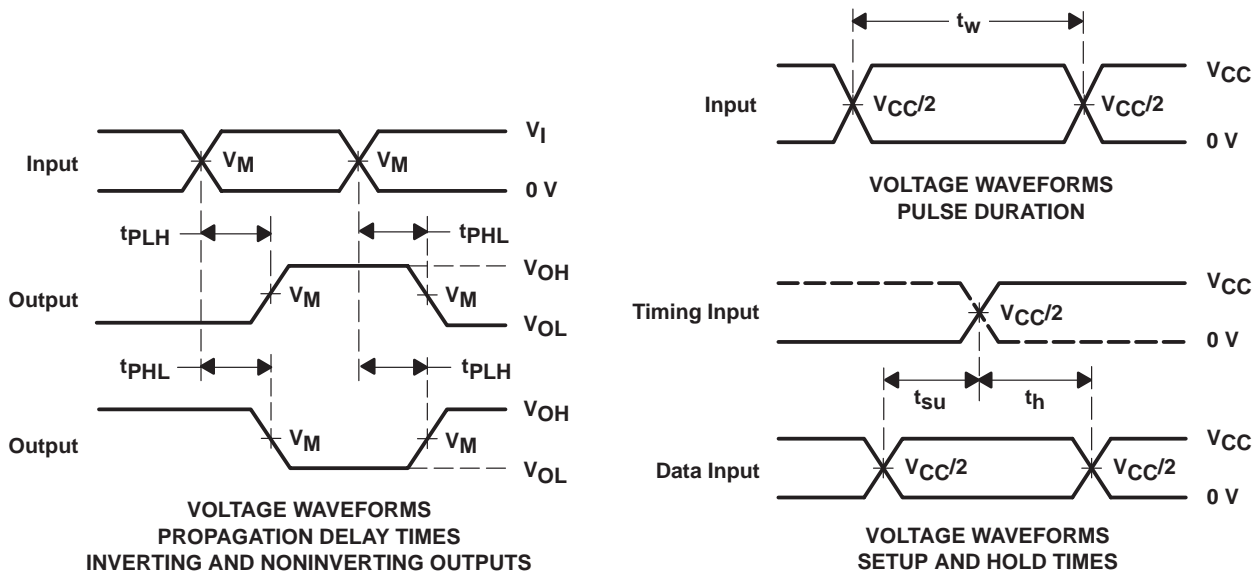

- NOTES: A. C_L includes probe and jig capacitance.
 B. All input pulses are supplied by generators having the following characteristics: $PRR \leq 10\text{ MHz}$, $Z_O = 50\ \Omega$, $t_r/t_f = 3\text{ ns}$.
 C. The outputs are measured one at a time, with one transition per measurement.
 D. t_{PLH} and t_{PHL} are the same as t_{pd} .
 E. All parameters and waveforms are not applicable to all devices.

Figure 3. Load Circuit and Voltage Waveforms

PARAMETER MEASUREMENT INFORMATION
(Enable and Disable Times)

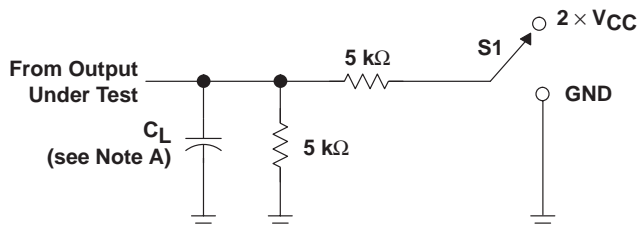

TEST	S1
t_{PLZ}/t_{PZL} t_{PHZ}/t_{PZH}	$2 \times V_{CC}$ GND

LOAD CIRCUIT

	$V_{CC} = 0.8 \text{ V}$	$V_{CC} = 1.2 \text{ V}$ $\pm 0.1 \text{ V}$	$V_{CC} = 1.5 \text{ V}$ $\pm 0.1 \text{ V}$	$V_{CC} = 1.8 \text{ V}$ $\pm 0.15 \text{ V}$	$V_{CC} = 2.5 \text{ V}$ $\pm 0.2 \text{ V}$	$V_{CC} = 3.3 \text{ V}$ $\pm 0.3 \text{ V}$
C_L	5, 10, 15, 30 pF	5, 10, 15, 30 pF	5, 10, 15, 30 pF	5, 10, 15, 30 pF	5, 10, 15, 30 pF	5, 10, 15, 30 pF
V_M	$V_{CC}/2$	$V_{CC}/2$	$V_{CC}/2$	$V_{CC}/2$	$V_{CC}/2$	$V_{CC}/2$
V_I	V_{CC}	V_{CC}	V_{CC}	V_{CC}	V_{CC}	V_{CC}
V_{Δ}	0.1 V	0.1 V	0.1 V	0.15 V	0.15 V	0.3 V

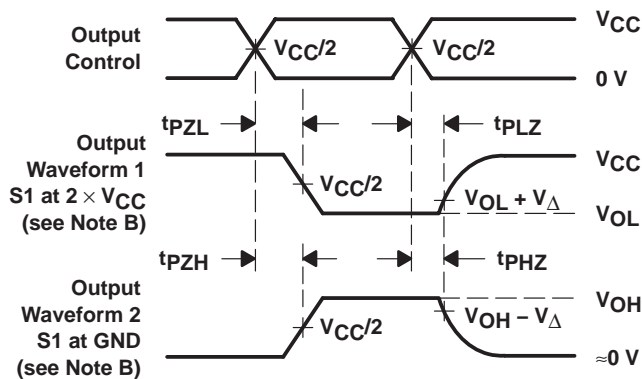

VOLTAGE WAVEFORMS
ENABLE AND DISABLE TIMES
LOW- AND HIGH-LEVEL ENABLING

- NOTES:
- A. C_L includes probe and jig capacitance.
 - B. Waveform 1 is for an output with internal conditions such that the output is low, except when disabled by the output control. Waveform 2 is for an output with internal conditions such that the output is high, except when disabled by the output control.
 - C. All input pulses are supplied by generators having the following characteristics: PRR $\leq 10 \text{ MHz}$, $Z_O = 50 \Omega$, $t_r/t_f = 3 \text{ ns}$.
 - D. The outputs are measured one at a time, with one transition per measurement.
 - E. t_{PLZ} and t_{PHZ} are the same as t_{dis} .
 - F. t_{PZL} and t_{PZH} are the same as t_{en} .
 - G. All parameters and waveforms are not applicable to all devices.

Figure 4. Load Circuit and Voltage Waveforms

PACKAGING INFORMATION

Orderable Device	Status ⁽¹⁾	Package Type	Package Drawing	Pins	Package Qty	Eco Plan ⁽²⁾	Lead/Ball Finish	MSL Peak Temp ⁽³⁾
74AUP1G126DBVRE4	ACTIVE	SOT-23	DBV	5	3000	Green (RoHS & no Sb/Br)	CU NIPDAU	Level-1-260C-UNLIM
74AUP1G126DBVRG4	ACTIVE	SOT-23	DBV	5	3000	Green (RoHS & no Sb/Br)	CU NIPDAU	Level-1-260C-UNLIM
74AUP1G126DBVTE4	ACTIVE	SOT-23	DBV	5	250	Green (RoHS & no Sb/Br)	CU NIPDAU	Level-1-260C-UNLIM
74AUP1G126DBVTG4	ACTIVE	SOT-23	DBV	5	250	Green (RoHS & no Sb/Br)	CU NIPDAU	Level-1-260C-UNLIM
74AUP1G126DCKRE4	ACTIVE	SC70	DCK	5	3000	Green (RoHS & no Sb/Br)	CU NIPDAU	Level-1-260C-UNLIM
74AUP1G126DCKRG4	ACTIVE	SC70	DCK	5	3000	Green (RoHS & no Sb/Br)	CU NIPDAU	Level-1-260C-UNLIM
74AUP1G126DCKTE4	ACTIVE	SC70	DCK	5	250	Green (RoHS & no Sb/Br)	CU NIPDAU	Level-1-260C-UNLIM
74AUP1G126DCKTG4	ACTIVE	SC70	DCK	5	250	Green (RoHS & no Sb/Br)	CU NIPDAU	Level-1-260C-UNLIM
74AUP1G126DRLRG4	ACTIVE	SOT	DRL	5	4000	Green (RoHS & no Sb/Br)	CU NIPDAU	Level-1-260C-UNLIM
SN74AUP1G126DBVR	ACTIVE	SOT-23	DBV	5	3000	Green (RoHS & no Sb/Br)	CU NIPDAU	Level-1-260C-UNLIM
SN74AUP1G126DBVT	ACTIVE	SOT-23	DBV	5	250	Green (RoHS & no Sb/Br)	CU NIPDAU	Level-1-260C-UNLIM
SN74AUP1G126DCKR	ACTIVE	SC70	DCK	5	3000	Green (RoHS & no Sb/Br)	CU NIPDAU	Level-1-260C-UNLIM
SN74AUP1G126DCKT	ACTIVE	SC70	DCK	5	250	Green (RoHS & no Sb/Br)	CU NIPDAU	Level-1-260C-UNLIM
SN74AUP1G126DRLR	ACTIVE	SOT	DRL	5	4000	Green (RoHS & no Sb/Br)	CU NIPDAU	Level-1-260C-UNLIM
SN74AUP1G126YZPR	ACTIVE	DSBGA	YZP	5	3000	Green (RoHS & no Sb/Br)	SNAGCU	Level-1-260C-UNLIM

⁽¹⁾ The marketing status values are defined as follows:

ACTIVE: Product device recommended for new designs.

LIFEBUY: TI has announced that the device will be discontinued, and a lifetime-buy period is in effect.

NRND: Not recommended for new designs. Device is in production to support existing customers, but TI does not recommend using this part in a new design.

PREVIEW: Device has been announced but is not in production. Samples may or may not be available.

OBSELETE: TI has discontinued the production of the device.

⁽²⁾ Eco Plan - The planned eco-friendly classification: Pb-Free (RoHS), Pb-Free (RoHS Exempt), or Green (RoHS & no Sb/Br) - please check <http://www.ti.com/productcontent> for the latest availability information and additional product content details.

TBD: The Pb-Free/Green conversion plan has not been defined.

Pb-Free (RoHS): TI's terms "Lead-Free" or "Pb-Free" mean semiconductor products that are compatible with the current RoHS requirements for all 6 substances, including the requirement that lead not exceed 0.1% by weight in homogeneous materials. Where designed to be soldered at high temperatures, TI Pb-Free products are suitable for use in specified lead-free processes.

Pb-Free (RoHS Exempt): This component has a RoHS exemption for either 1) lead-based flip-chip solder bumps used between the die and package, or 2) lead-based die adhesive used between the die and leadframe. The component is otherwise considered Pb-Free (RoHS compatible) as defined above.

Green (RoHS & no Sb/Br): TI defines "Green" to mean Pb-Free (RoHS compatible), and free of Bromine (Br) and Antimony (Sb) based flame retardants (Br or Sb do not exceed 0.1% by weight in homogeneous material)

⁽³⁾ MSL, Peak Temp. -- The Moisture Sensitivity Level rating according to the JEDEC industry standard classifications, and peak solder temperature.

Important Information and Disclaimer:The information provided on this page represents TI's knowledge and belief as of the date that it is provided. TI bases its knowledge and belief on information provided by third parties, and makes no representation or warranty as to the accuracy of such information. Efforts are underway to better integrate information from third parties. TI has taken and continues to take reasonable steps to provide representative and accurate information but may not have conducted destructive testing or chemical analysis on incoming materials and chemicals. TI and TI suppliers consider certain information to be proprietary, and thus CAS numbers and other limited information may not be available for release.

In no event shall TI's liability arising out of such information exceed the total purchase price of the TI part(s) at issue in this document sold by TI to Customer on an annual basis.

TAPE AND REEL INFORMATION

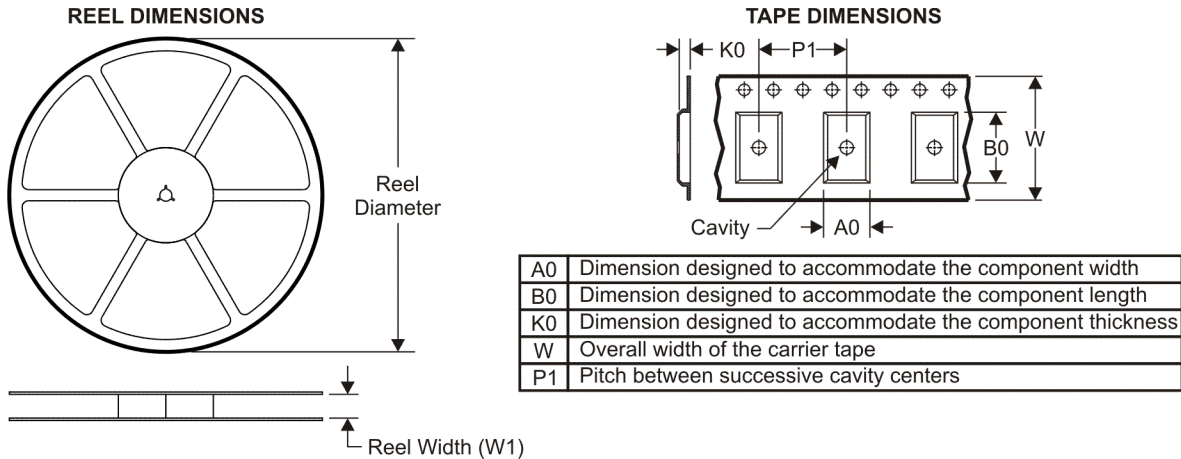

QUADRANT ASSIGNMENTS FOR PIN 1 ORIENTATION IN TAPE

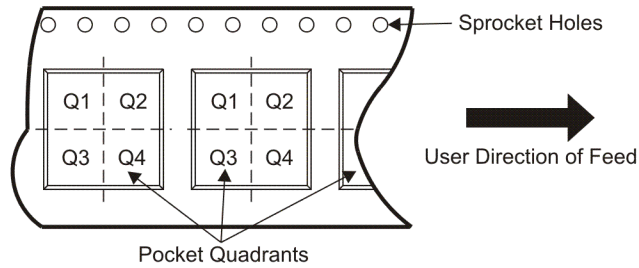

*All dimensions are nominal

Device	Package Type	Package Drawing	Pins	SPQ	Reel Diameter (mm)	Reel Width W1 (mm)	A0 (mm)	B0 (mm)	K0 (mm)	P1 (mm)	W (mm)	Pin1 Quadrant
SN74AUP1G126DBVR	SOT-23	DBV	5	3000	180.0	9.2	3.23	3.17	1.37	4.0	8.0	Q3
SN74AUP1G126DBVT	SOT-23	DBV	5	250	180.0	9.2	3.23	3.17	1.37	4.0	8.0	Q3
SN74AUP1G126DCKR	SC70	DCK	5	3000	180.0	9.2	2.24	2.34	1.22	4.0	8.0	Q3
SN74AUP1G126DCKT	SC70	DCK	5	250	180.0	9.2	2.24	2.34	1.22	4.0	8.0	Q3
SN74AUP1G126DRLR	SOT	DRL	5	4000	180.0	9.2	1.78	1.78	0.69	4.0	8.0	Q3
SN74AUP1G126YZPR	DSBGA	YZP	5	3000	180.0	8.4	1.02	1.52	0.66	4.0	8.0	Q1

TAPE AND REEL BOX DIMENSIONS



*All dimensions are nominal

Device	Package Type	Package Drawing	Pins	SPQ	Length (mm)	Width (mm)	Height (mm)
SN74AUP1G126DBVR	SOT-23	DBV	5	3000	202.0	201.0	28.0
SN74AUP1G126DBVT	SOT-23	DBV	5	250	202.0	201.0	28.0
SN74AUP1G126DCKR	SC70	DCK	5	3000	202.0	201.0	28.0
SN74AUP1G126DCKT	SC70	DCK	5	250	202.0	201.0	28.0
SN74AUP1G126DRLR	SOT	DRL	5	4000	202.0	201.0	28.0
SN74AUP1G126YZPR	DSBGA	YZP	5	3000	220.0	220.0	34.0

DBV (R-PDSO-G5)

PLASTIC SMALL-OUTLINE PACKAGE

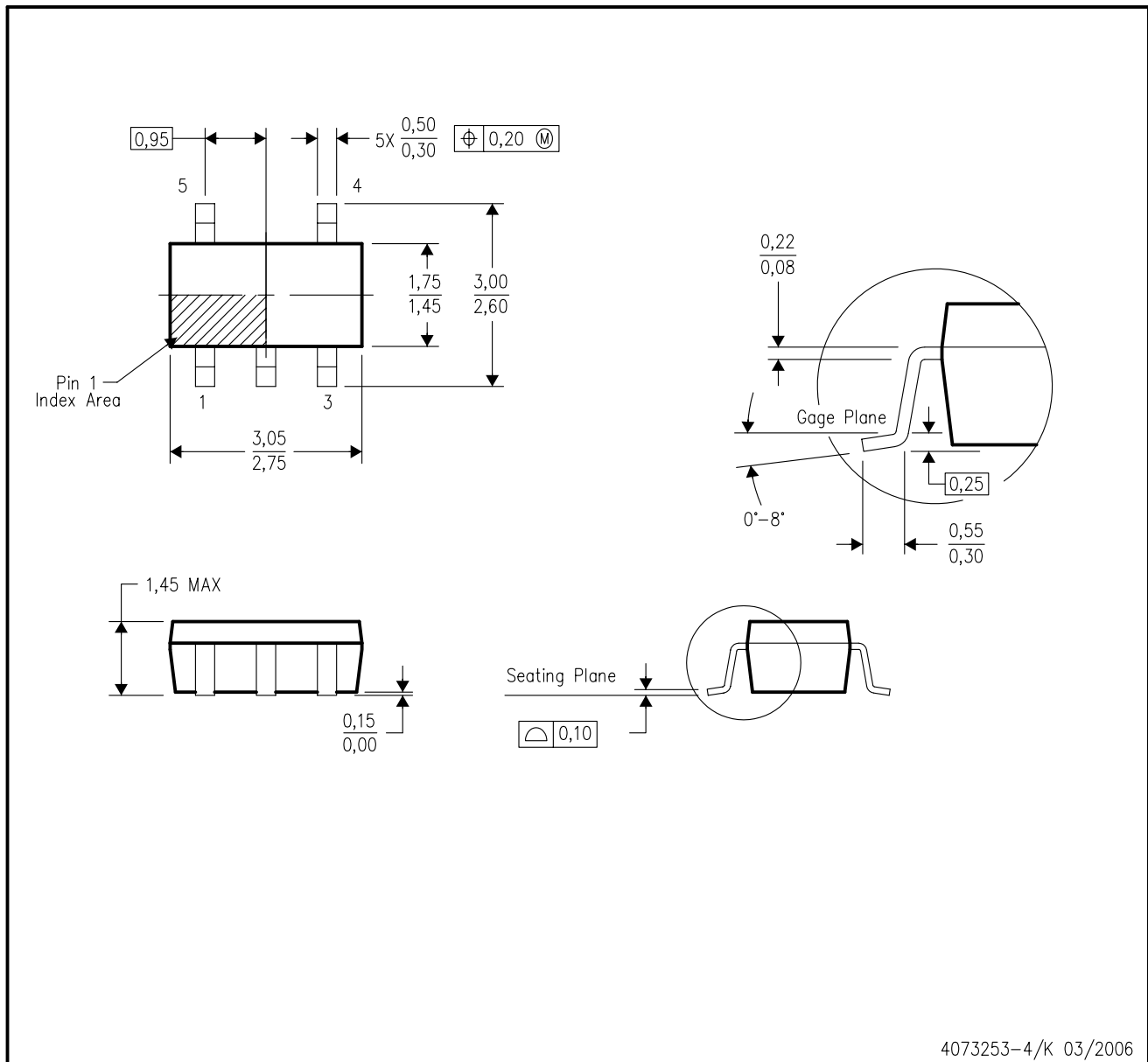

- NOTES:
- A. All linear dimensions are in millimeters.
 - B. This drawing is subject to change without notice.
 - C. Body dimensions do not include mold flash or protrusion. Mold flash and protrusion shall not exceed 0.15 per side.
 - D. Falls within JEDEC MO-178 Variation AA.

DCK (R-PDSO-G5)

PLASTIC SMALL-OUTLINE PACKAGE



- NOTES:
- A. All linear dimensions are in millimeters.
 - B. This drawing is subject to change without notice.
 - C. Body dimensions do not include mold flash or protrusion. Mold flash and protrusion shall not exceed 0.15 per side.
 - D. Falls within JEDEC MO-203 variation AA.



- NOTES:
- A. All linear dimensions are in millimeters. Dimensioning and tolerancing per ASME Y14.5M-1994.
 - B. This drawing is subject to change without notice.
 - C. Body dimensions do not include mold flash, interlead flash, protrusions, or gate burrs. Mold flash, interlead flash, protrusions, or gate burrs shall not exceed 0,15 per end or side.
 - D. JEDEC package registration is pending.

YZP (R-XBGA-N5)

DIE-SIZE BALL GRID ARRAY

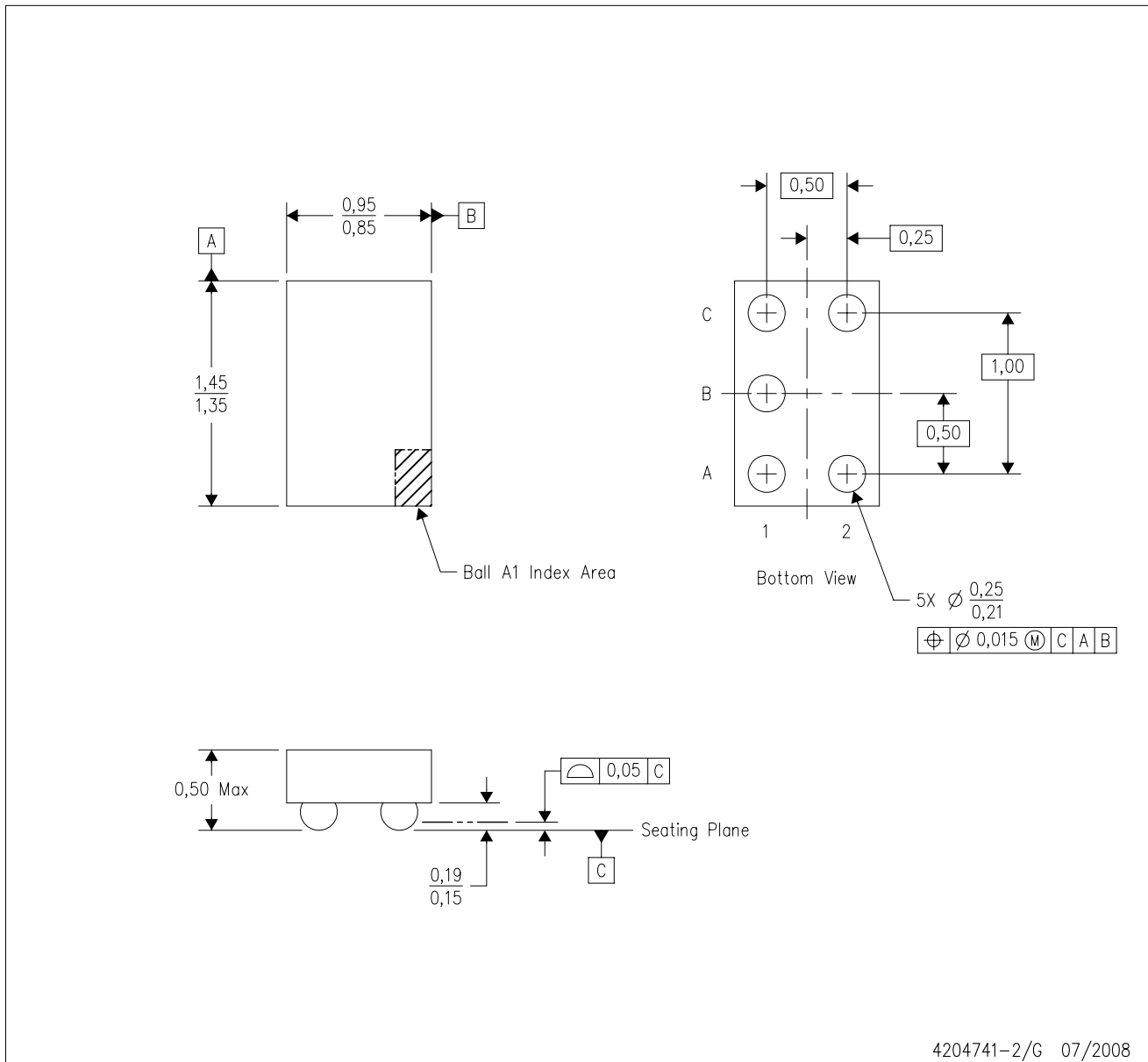

- NOTES:
- A. All linear dimensions are in millimeters. Dimensioning and tolerancing per ASME Y14.5M-1994.
 - B. This drawing is subject to change without notice.
 - C. NanoFree™ package configuration.
 - D. This package is lead-free. Refer to the 5 YEP package (drawing 4204725) for tin-lead (SnPb).

NanoFree is a trademark of Texas Instruments.

IMPORTANT NOTICE

Texas Instruments Incorporated and its subsidiaries (TI) reserve the right to make corrections, modifications, enhancements, improvements, and other changes to its products and services at any time and to discontinue any product or service without notice. Customers should obtain the latest relevant information before placing orders and should verify that such information is current and complete. All products are sold subject to TI's terms and conditions of sale supplied at the time of order acknowledgment.

TI warrants performance of its hardware products to the specifications applicable at the time of sale in accordance with TI's standard warranty. Testing and other quality control techniques are used to the extent TI deems necessary to support this warranty. Except where mandated by government requirements, testing of all parameters of each product is not necessarily performed.

TI assumes no liability for applications assistance or customer product design. Customers are responsible for their products and applications using TI components. To minimize the risks associated with customer products and applications, customers should provide adequate design and operating safeguards.

TI does not warrant or represent that any license, either express or implied, is granted under any TI patent right, copyright, mask work right, or other TI intellectual property right relating to any combination, machine, or process in which TI products or services are used. Information published by TI regarding third-party products or services does not constitute a license from TI to use such products or services or a warranty or endorsement thereof. Use of such information may require a license from a third party under the patents or other intellectual property of the third party, or a license from TI under the patents or other intellectual property of TI.

Reproduction of TI information in TI data books or data sheets is permissible only if reproduction is without alteration and is accompanied by all associated warranties, conditions, limitations, and notices. Reproduction of this information with alteration is an unfair and deceptive business practice. TI is not responsible or liable for such altered documentation. Information of third parties may be subject to additional restrictions.

Resale of TI products or services with statements different from or beyond the parameters stated by TI for that product or service voids all express and any implied warranties for the associated TI product or service and is an unfair and deceptive business practice. TI is not responsible or liable for any such statements.

TI products are not authorized for use in safety-critical applications (such as life support) where a failure of the TI product would reasonably be expected to cause severe personal injury or death, unless officers of the parties have executed an agreement specifically governing such use. Buyers represent that they have all necessary expertise in the safety and regulatory ramifications of their applications, and acknowledge and agree that they are solely responsible for all legal, regulatory and safety-related requirements concerning their products and any use of TI products in such safety-critical applications, notwithstanding any applications-related information or support that may be provided by TI. Further, Buyers must fully indemnify TI and its representatives against any damages arising out of the use of TI products in such safety-critical applications.

TI products are neither designed nor intended for use in military/aerospace applications or environments unless the TI products are specifically designated by TI as military-grade or "enhanced plastic." Only products designated by TI as military-grade meet military specifications. Buyers acknowledge and agree that any such use of TI products which TI has not designated as military-grade is solely at the Buyer's risk, and that they are solely responsible for compliance with all legal and regulatory requirements in connection with such use.

TI products are neither designed nor intended for use in automotive applications or environments unless the specific TI products are designated by TI as compliant with ISO/TS 16949 requirements. Buyers acknowledge and agree that, if they use any non-designated products in automotive applications, TI will not be responsible for any failure to meet such requirements.

Following are URLs where you can obtain information on other Texas Instruments products and application solutions:

Products

Amplifiers	amplifier.ti.com
Data Converters	dataconverter.ti.com
DSP	dsp.ti.com
Clocks and Timers	www.ti.com/clocks
Interface	interface.ti.com
Logic	logic.ti.com
Power Mgmt	power.ti.com
Microcontrollers	microcontroller.ti.com
RFID	www.ti-rfid.com
RF/IF and ZigBee® Solutions	www.ti.com/lprf

Applications

Audio	www.ti.com/audio
Automotive	www.ti.com/automotive
Broadband	www.ti.com/broadband
Digital Control	www.ti.com/digitalcontrol
Medical	www.ti.com/medical
Military	www.ti.com/military
Optical Networking	www.ti.com/opticalnetwork
Security	www.ti.com/security
Telephony	www.ti.com/telephony
Video & Imaging	www.ti.com/video
Wireless	www.ti.com/wireless

Mailing Address: Texas Instruments, Post Office Box 655303, Dallas, Texas 75265
Copyright © 2008, Texas Instruments Incorporated