

# SN54ALS878A, SN54ALS879A, SN54AS878, SN54AS879 SN74ALS878A, SN74ALS879A, SN74AS878, SN74AS879 DUAL 4-BIT D-TYPE EDGE-TRIGGERED FLIP-FLOPS WITH 3-STATE OUTPUTS

SDAS062A – D2661, APRIL 1982 – REVISED MAY 1986

- 3-State Bus Driving Outputs
- Full Parallel-Access for Loading
- Buffered Control Inputs
- Choice of True or Inverting Logic
  - 'ALS878A, 'AS878 True Outputs
  - 'ALS879A, 'AS879 Inverting Outputs
- Synchronous Clear
- Package Options Include Plastic Small Outline Packages, Both Plastic and Ceramic Chip Carriers, and Standard Plastic and Ceramic 300-mil DIPs
- Dependable Texas Instruments Quality and Reliability

## description

These dual 4-bit registers feature 3-state outputs designed specifically for bus driving. This makes these devices particularly suitable for implementing buffer registers, I/O ports, bidirectional bus drivers, and working registers.

The dual 4-bit edge-triggered flip-flops enter data on the low-to-high transition of the clock (1CLK and 2CLK). All types have individual synchronous clear inputs and output control pins for each group of 4-bit registers.

The SN54ALS' and SN54AS' devices are characterized for operation over the full military temperature range of  $-55^{\circ}\text{C}$  to  $125^{\circ}\text{C}$ . The SN74ALS' and SN74AS' devices are characterized for operation from  $0^{\circ}\text{C}$  to  $70^{\circ}\text{C}$ .

SN54ALS878A, SN54AS878 . . . JT PACKAGE  
SN74ALS878A, SN74AS878 . . . DW OR NT PACKAGE  
(TOP VIEW)

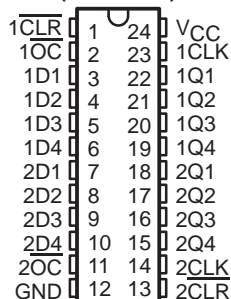

SN54ALS878A, SN54AS878 . . . FK PACKAGE  
SN74ALS878A, SN74AS878 . . . FN PACKAGE  
(TOP VIEW)

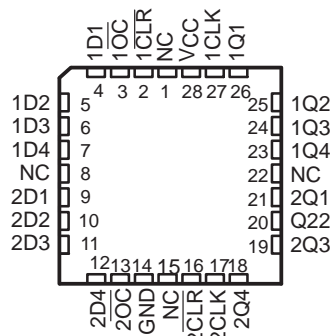

SN54ALS879A, SN54AS879 . . . JT PACKAGE  
SN74ALS879A, SN74AS879 . . . DW OR NT PACKAGE  
(TOP VIEW)

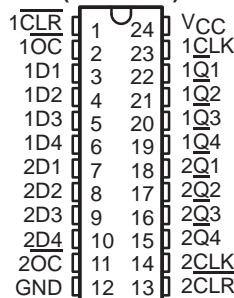

SN54ALS879A, SN54AS879 . . . FK PACKAGE  
SN74ALS879A, SN74AS879 . . . FN PACKAGE  
(TOP VIEW)

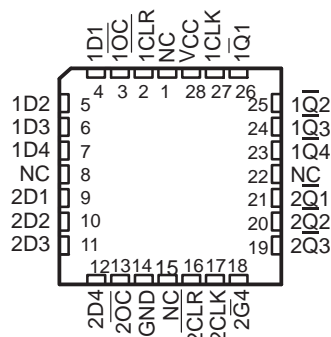

NC – No internal connection

PRODUCTION DATA information is current as of publication date. Products conform to specifications per the terms of Texas Instruments standard warranty. Production processing does not necessarily include testing of all parameters.



POST OFFICE BOX 655303 • DALLAS, TEXAS 75265

Copyright © 1986, Texas Instruments Incorporated

**SN54ALS878A, SN54ALS879A, SN54AS878, SN54AS879  
 SN74ALS878A, SN74ALS879A, SN74AS878, SN74AS879  
 DUAL 4-BIT D-TYPE EDGE-TRIGGERED FLIP-FLOPS WITH 3-STATE OUTPUTS**

SDAS062A – D2661, APRIL 1982 – REVISED MAY 1986

**FUNCTION TABLES**

'ALS878A, 'AS878  
(each flip-flop)

INPUTS				OUTPUT
OC	CLR	CLK	D	Q
L	L	↑	X	L
L	H	↑	H	H
L	H	↑	L	L
L	H	L	X	Q <sub>0</sub>
H	X	X	X	Z

'ALS879A, 'AS879  
(each flip-flop)

INPUTS				OUTPUT
OC	CLR	CLK	D	$\overline{Q}$
L	L	↑	X	H
L	H	↑	H	L
L	H	↑	L	H
L	H	L	X	Q <sub>0</sub>
H	X	X	X	Z

**logic symbols †**

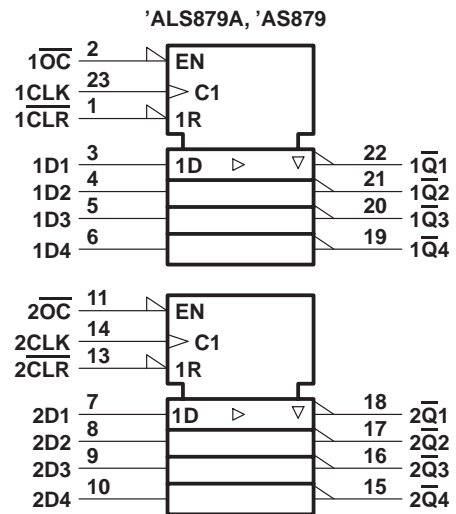
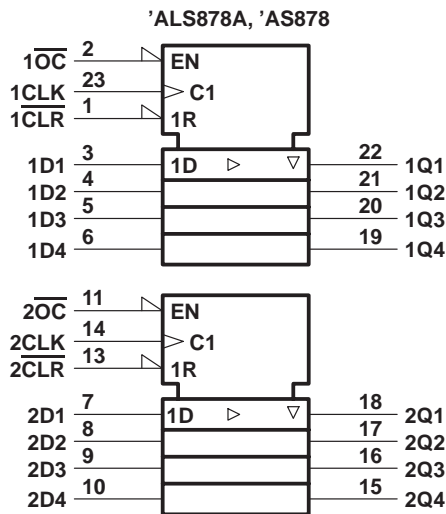

† These symbols are in accordance with ANSI/IEEE Std 91-1984 and IEC Publication 617-12. Pin numbers shown are for DW, JT, and NT packages.

DUAL 4-BIT D-TYPE EDGE-TRIGGERED FLIP-FLOPS WITH 3-STATE OUTPUTS

SDAS062A – D2661, APRIL 1982 – REVISED MAY 1986

logic diagrams (positive logic)

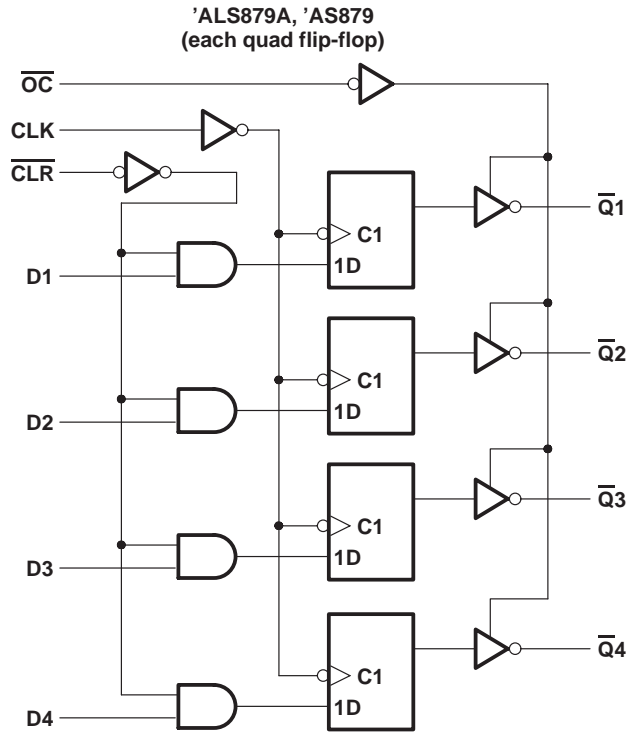
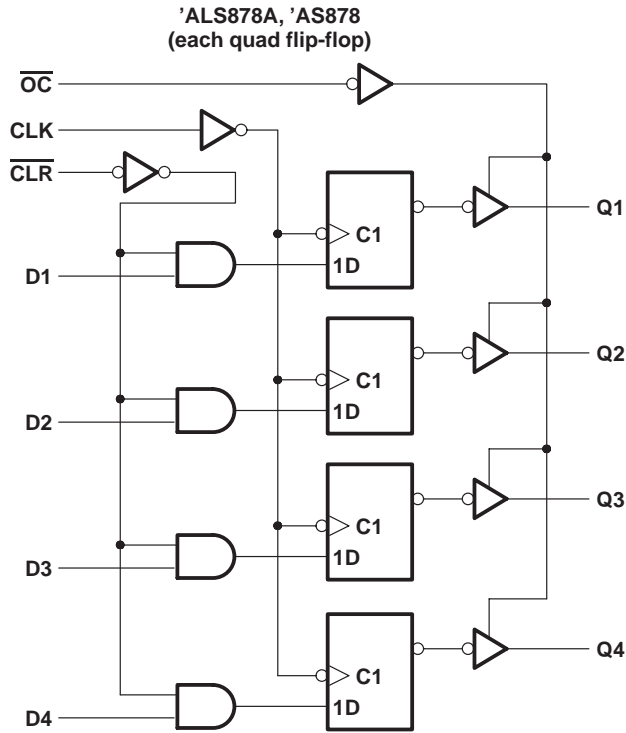

Pin numbers shown are for DW, JT, and NT packages.

# SN54ALS878A, SN54ALS879A

# SN74ALS878A, SN74ALS879A

## DUAL 4-BIT D-TYPE EDGE-TRIGGERED FLIP-FLOPS WITH 3-STATE OUTPUTS

SDAS062A – D2661, APRIL 1982 – REVISED MAY 1986

### absolute maximum ratings over operating free-air temperature range (unless otherwise noted)

Supply voltage, $V_{CC}$ .....	7 V
Input voltage .....	7 V
Voltage applied to a disabled 3-state output .....	5.5 V
Operating free-air temperature range: SN54ALS878A, SN54ALS879A .....	-55°C to 125°C
SN74ALS878A, SN74ALS879A .....	0°C to 70°C
Storage temperature range .....	-65°C to 150°C

### recommended operating conditions

		SN54ALS878A SN54ALS879A			SN74ALS878A SN74ALS879A			UNIT
		MIN	NOM	MAX	MIN	NOM	MAX	
$V_{CC}$	Supply voltage	4.5	5	5.5	4.5	5	5.5	V
$V_{IH}$	High-level input voltage	2			2			V
$V_{IL}$	Low-level input voltage			0.7			0.8	V
$I_{OH}$	High-level output current			-1			-2.6	mA
$I_{OL}$	Low-level output current			12			24	mA
$f_{clock}$	Clock frequency	'ALS878A	0	25	0	30		MHz
		'ALS879A	0	20	0	25		
$t_w$	Pulse duration	'ALS878A CLK high or low	20		16.5			ns
		'ALS879A CLK high or low	25		20			
$t_{su}$	Setup time before CLK↑	Data	15		15			ns
		CLR	20		20			
$t_h$	Hold time after CLK↑	Data	4		4			ns
		CLR	0		0			
$T_A$	Operating free-air temperature	-55		125	0		70°	°C

### electrical characteristics over recommended operating free-air temperature range (unless otherwise noted)

PARAMETER	TEST CONDITIONS	SN54ALS878A SN54ALS879A			SN74ALS878A SN74ALS879A			UNIT
		MIN	TYP†	MAX	MIN	TYP†	MAX	
$V_{IK}$	$V_{CC} = 4.5 V$ , $I_I = -18 mA$			-1.2			-1.2	V
$V_{OH}$	$V_{CC} = 4.5 V$ to $5.5 V$ , $I_{OH} = -0.4 mA$	$V_{CC} - 2$			$V_{CC} - 2$			V
	$V_{CC} = 4.5 V$ , $I_{OH} = -1 mA$	2.4	3.3					
	$V_{CC} = 4.5 V$ , $I_{OH} = -2.6 mA$				2.4	3.2		
$V_{OL}$	$V_{CC} = 4.5 V$ , $I_{OL} = 12 mA$		0.25	0.4		0.25	0.4	V
	$V_{CC} = 4.5 V$ , $I_{OL} = 24 mA$					0.35	0.5	
$I_{OZH}$	$V_{CC} = 5.5 V$ , $V_O = 2.7 V$			20			20	μA
$I_{OZL}$	$V_{CC} = 5.5 V$ , $V_O = 0.4 V$			-20			-20	μA
$I_I$	$V_{CC} = 5.5 V$ , $V_I = 7 V$			0.1			0.1	mA
$I_{IH}$	$V_{CC} = 5.5 V$ , $V_O = 2.7 V$			20			20	μA
$I_{IL}$	$V_{CC} = 5.5 V$ , $V_I = 0.4 V$			-0.2			-0.2	mA
$I_{O‡}$	$V_{CC} = 5.5 V$ , $V_O = 2.25 V$	-30		-112	-30		-112	mA
$I_{CC}$	$V_{CC} = 5.5 V$	Outputs high	14	23	14	23		mA
		Outputs low	18	31	18	31		
		Outputs disabled	20	33	20	33		

† All typical values are at  $V_{CC} = 5 V$ ,  $T_A = 25°C$ .

‡ The output conditions have been chosen to produce a current that closely approximates one half of the true short-circuit output current,  $I_{OS}$ .



DUAL 4-BIT D-TYPE EDGE-TRIGGERED FLIP-FLOPS WITH 3-STATE OUTPUTS

SDAS062A – D2661, APRIL 1982 – REVISED MAY 1986

switching characteristics (see Note 1)

PARAMETER	FROM (INPUT)	TO (OUTPUT)	V <sub>CC</sub> = 5 V, C <sub>L</sub> = 50 pF, R1 = 500 Ω, R2 = 500 Ω, T <sub>A</sub> = 25°C			V <sub>CC</sub> = 4.5 V to 5.5 V, C <sub>L</sub> = 50 pF, R1 = 500 Ω, R2 = 500 Ω, T <sub>A</sub> = MIN to MAX			UNIT	
			'ALS878A 'ALS879A			SN54ALS878A SN54ALS879A	SN74ALS878A SN74ALS879A			
			MIN	TYP	MAX	MIN	MAX	MIN		MAX
f <sub>max</sub>	'ALS878A		40	50		25		30	MHz	
	'ALS879A		40	50		20		25		
t <sub>PLH</sub>	CLK	Q or $\bar{Q}$		8	10	4	15	4	14	ns
t <sub>PHL</sub>				9	13	4	17	4	16	
t <sub>PZH</sub>	$\bar{OC}$	Q or $\bar{Q}$		9	13	4	22	4	20	ns
t <sub>PZL</sub>				11	15	4	22	4	20	
t <sub>PHZ</sub>	$\bar{OC}$	Q or $\bar{Q}$		6	8	2	12	2	10	ns
t <sub>PLZ</sub>				7	10	3	18	3	15	

NOTE 1: Load circuit and voltage waveforms are shown in Section 1.

SN54AS878, SN54AS879

SN74AS878, SN74AS879

DUAL 4-BIT D-TYPE EDGE-TRIGGERED FLIP-FLOPS WITH 3-STATE OUTPUTS

SDAS062A – D2661, APRIL 1982 – REVISED MAY 1986

absolute maximum ratings over operating free-air temperature range (unless otherwise noted)

Supply voltage, $V_{CC}$	7 V
Input voltage	7 V
Voltage applied to a disabled 3-state output	5.5 V
Operating free-air temperature range: SN54AS878, SN54AS879	-55°C to 125°C
SN74AS878, SN74AS879	0°C to 70°C
Storage temperature range	-65°C to 150°C

recommended operating conditions

		SN54AS878 SN54AS879			SN74AS878 SN74AS879			UNIT
		MIN	NOM	MAX	MIN	NOM	MAX	
$V_{CC}$	Supply voltage	4.5	5	5.5	4.5	5	5.5	V
$V_{IH}$	High-level input voltage	2			2			V
$V_{IL}$	Low-level input voltage			0.8			0.8	V
$I_{OH}$	High-level output current			-12			-15	mA
$I_{OL}$	Low-level output current			32			48	mA
$f_{clock}$	Clock Frequency	0		100	0		125	MHz
$t_w$	Pulse duration	CLK low		4		2		ns
		CLK high		5		4		
$t_{su}$	Setup time before CLK↑	Data		3		2		ns
		CLR		6.5		5.5		
$t_h$	Hold time after CLK↑	Data		3		2		ns
		CLR		0		0		
$T_A$	Operating free-air temperature		-55	125		0	70°	°C



DUAL 4-BIT D-TYPE EDGE-TRIGGERED FLIP-FLOPS WITH 3-STATE OUTPUTS

SDAS062A – D2661, APRIL 1982 – REVISED MAY 1986

electrical characteristics over recommended operating free-air temperature range (unless otherwise noted)

PARAMETER	TEST CONDITIONS		SN54AS878 SN54AS879			SN74AS878 SN74AS879			UNIT
			MIN	TYP <sup>†</sup>	MAX	MIN	TYP <sup>†</sup>	MAX	
V <sub>IK</sub>	V <sub>CC</sub> = 4.5 V,	I <sub>I</sub> = -18 mA			-1.2			-1.2	V
V <sub>OH</sub>	V <sub>CC</sub> = 4.5 V to 5.5 V,	I <sub>OH</sub> = -2 mA	V <sub>CC</sub> -2			V <sub>CC</sub> -2			V
	V <sub>CC</sub> = 4.5 V,	I <sub>OH</sub> = -12 mA	2.4	3.2					
	V <sub>CC</sub> = 4.5 V,	I <sub>OH</sub> = -15 mA				2.4	3.3		
V <sub>OL</sub>	V <sub>CC</sub> = 4.5 V,	I <sub>OL</sub> = 32 mA	0.29	0.5				V	
	V <sub>CC</sub> = 4.5 V,	I <sub>OL</sub> = 48 mA				0.33	0.5		
I <sub>OZH</sub>	V <sub>CC</sub> = 5.5 V,	V <sub>O</sub> = 2.7 V			50			50	μA
I <sub>OZL</sub>	V <sub>CC</sub> = 5.5 V,	V <sub>O</sub> = 0.4 V			-50			-50	μA
I <sub>I</sub>	V <sub>CC</sub> = 5.5 V,	V <sub>I</sub> = 7 V			0.1			0.1	mA
I <sub>IH</sub>	V <sub>CC</sub> = 5.5 V,	V <sub>I</sub> = 2.7 V			20			20	μA
I <sub>IL</sub>	D	V <sub>CC</sub> = 5.5 V, V <sub>I</sub> = 0.4 V			-3			-2	mA
	All other				-0.5			-0.5	
I <sub>O<sup>†</sup></sub>	V <sub>CC</sub> = 5.5 V,	V <sub>O</sub> = 2.25 V	-30		-112	-30		-112	mA
I <sub>CC</sub>	'AS878	V <sub>CC</sub> = 5.5 V, See Note 2	Outputs high	82	132	82	132	mA	
			Outputs low	96	155	96	155		
			Outputs disabled	100	160	100	160		
			Outputs high	88	142	88	142		
			Outputs low	94	150	94	150		
			Outputs disabled	100	160	100	160		
'AS879	V <sub>CC</sub> = 5.5 V, See Note 2	Outputs high	82	132	82	132	mA		
		Outputs low	96	155	96	155			
		Outputs disabled	100	160	100	160			
		Outputs high	88	142	88	142			
		Outputs low	94	150	94	150			
		Outputs disabled	100	160	100	160			

<sup>†</sup> All typical values are at V<sub>CC</sub> = 5 V, T<sub>A</sub> = 25°C.

<sup>‡</sup> The output conditions have been chosen to produce a current that closely approximates one half of the true short-circuit output current, I<sub>OS</sub>.

NOTE 2: I<sub>CC</sub> is measured with CLR and all D inputs grounded, and CLK and OC at 4.5 V.

switching characteristics (see Note 1)

PARAMETER	FROM (INPUT)	TO (OUTPUT)	V <sub>CC</sub> = 4.5 V to 5.5 V, C <sub>L</sub> = 50 pF, R <sub>1</sub> = 500 Ω, R <sub>2</sub> = 500 Ω, T <sub>A</sub> = MIN to MAX				UNIT
			SN54AS878 SN54AS879		SN74AS878 SN74AS879		
			MIN	MAX	MIN	MAX	
t <sub>max</sub>			100		125	MHz	
t <sub>PLH</sub>	CLK	Q or $\bar{Q}$	3	11.5	3	8.5	ns
t <sub>PHL</sub>			4	12.5	4	10.5	
t <sub>PZH</sub>	$\bar{OC}$	Q or $\bar{Q}$	2	8	2	7	ns
t <sub>PZL</sub>			3	11.5	3	10.5	
t <sub>PHZ</sub>	$\bar{OC}$	Q or $\bar{Q}$	2	7	2	6	ns
t <sub>PLZ</sub>			2	7	2	6	

NOTE 1: Load circuit and voltage waveforms are shown in Section 1.

## IMPORTANT NOTICE

Texas Instruments and its subsidiaries (TI) reserve the right to make changes to their products or to discontinue any product or service without notice, and advise customers to obtain the latest version of relevant information to verify, before placing orders, that information being relied on is current and complete. All products are sold subject to the terms and conditions of sale supplied at the time of order acknowledgement, including those pertaining to warranty, patent infringement, and limitation of liability.

TI warrants performance of its semiconductor products to the specifications applicable at the time of sale in accordance with TI's standard warranty. Testing and other quality control techniques are utilized to the extent TI deems necessary to support this warranty. Specific testing of all parameters of each device is not necessarily performed, except those mandated by government requirements.

CERTAIN APPLICATIONS USING SEMICONDUCTOR PRODUCTS MAY INVOLVE POTENTIAL RISKS OF DEATH, PERSONAL INJURY, OR SEVERE PROPERTY OR ENVIRONMENTAL DAMAGE ("CRITICAL APPLICATIONS"). TI SEMICONDUCTOR PRODUCTS ARE NOT DESIGNED, AUTHORIZED, OR WARRANTED TO BE SUITABLE FOR USE IN LIFE-SUPPORT DEVICES OR SYSTEMS OR OTHER CRITICAL APPLICATIONS. INCLUSION OF TI PRODUCTS IN SUCH APPLICATIONS IS UNDERSTOOD TO BE FULLY AT THE CUSTOMER'S RISK.

In order to minimize risks associated with the customer's applications, adequate design and operating safeguards must be provided by the customer to minimize inherent or procedural hazards.

TI assumes no liability for applications assistance or customer product design. TI does not warrant or represent that any license, either express or implied, is granted under any patent right, copyright, mask work right, or other intellectual property right of TI covering or relating to any combination, machine, or process in which such semiconductor products or services might be or are used. TI's publication of information regarding any third party's products or services does not constitute TI's approval, warranty or endorsement thereof.