

# SN54ALS874B, SN74ALS874B, SN74ALS876A SN74AS874, SN74AS876 DUAL 4-BIT D-TYPE EDGE-TRIGGERED FLIP-FLOPS

SDAS061C – APRIL 1982 – REVISED JANUARY 1995

- 3-State Buffer-Type Outputs Drive Bus Lines Directly
- Bus-Structured Pinout
- Choice of True or Inverting Logic
  - SN54ALS874B, SN74ALS874B, SN74AS874 Have True Outputs
  - SN74ALS876A, SN74AS876 Have Inverting Outputs
- Asynchronous Clear
- Package Options Include Plastic Small-Outline (DW) Packages, Plastic (FN) and Ceramic (FK) Chip Carriers, and Standard Plastic (NT) and Ceramic (JT) 300-mil DIPs

## description

These dual 4-bit D-type edge-triggered flip-flops feature 3-state outputs designed specifically as bus drivers. They are particularly suitable for implementing buffer registers, I/O ports, bidirectional bus drivers, and working registers.

The edge-triggered flip-flops enter data on the low-to-high transition of the clock (CLK) input. The SN54ALS874B, SN74ALS874B, and SN74AS874 have clear ( $\overline{\text{CLR}}$ ) inputs and noninverting Q outputs. The SN74ALS876A and SN74AS876 have preset ( $\overline{\text{PRE}}$ ) inputs and inverting  $\overline{\text{Q}}$  outputs; taking  $\overline{\text{PRE}}$  low causes the four Q or  $\overline{\text{Q}}$  outputs to go low independently of the clock.

The SN54ALS874B is characterized for operation over the full military temperature range of  $-55^{\circ}\text{C}$  to  $125^{\circ}\text{C}$ . The SN74ALS874B, SN74ALS876A, SN74AS874, and SN74AS876 devices are characterized for operation from  $0^{\circ}\text{C}$  to  $70^{\circ}\text{C}$ .

SN54ALS874B . . . JT PACKAGE  
SN74ALS874B, SN74AS874 . . . DW OR NT PACKAGE  
(TOP VIEW)

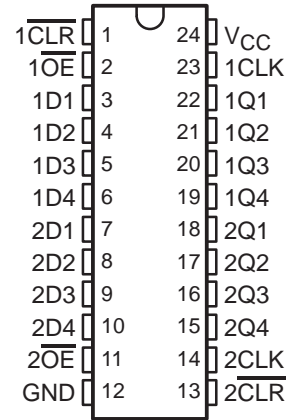

SN54ALS874B . . . FK PACKAGE  
(TOP VIEW)

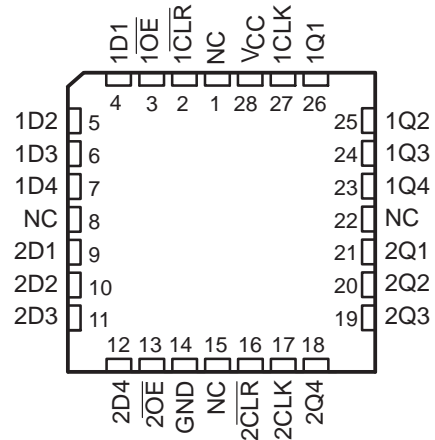

NC – No internal connection

SN74ALS876A, SN74AS876 . . . DW OR NT PACKAGE  
(TOP VIEW)

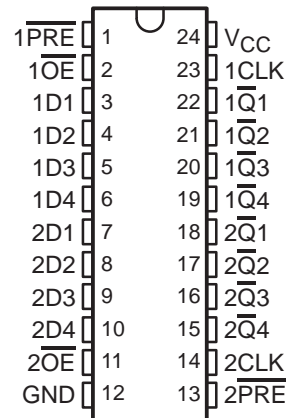

**SN54ALS874B, SN74ALS874B, SN74ALS876A  
SN74AS874, SN74AS876  
DUAL 4-BIT D-TYPE EDGE-TRIGGERED FLIP-FLOPS**

SDAS061C – APRIL 1982 – REVISED JANUARY 1995

**Function Tables**

**SN54ALS874B, SN74ALS874B, SN74AS874  
(each flip-flop)**

INPUTS				OUTPUT
$\overline{OE}$	$\overline{CLR}$	CLK	D	Q
L	L	X	X	L
L	H	↑	H	H
L	H	↑	L	L
L	H	L	X	Q <sub>0</sub>
H	X	X	X	Z

**SN74ALS876A, SN74AS876  
(each flip-flop)**

INPUTS				OUTPUT
$\overline{OE}$	$\overline{PRE}$	CLK	D	$\overline{Q}$
L	L	X	X	L
L	H	↑	H	L
L	H	↑	L	H
L	H	L	X	$\overline{Q}_0$
H	X	X	X	Z

**logic symbols†**

**SN54ALS874B, SN74ALS874B, SN74AS874**

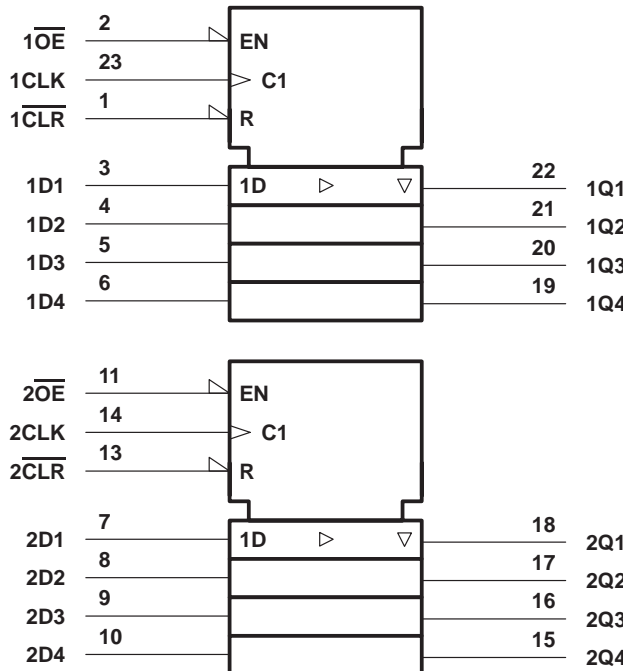

**SN74ALS876A, SN74AS876**

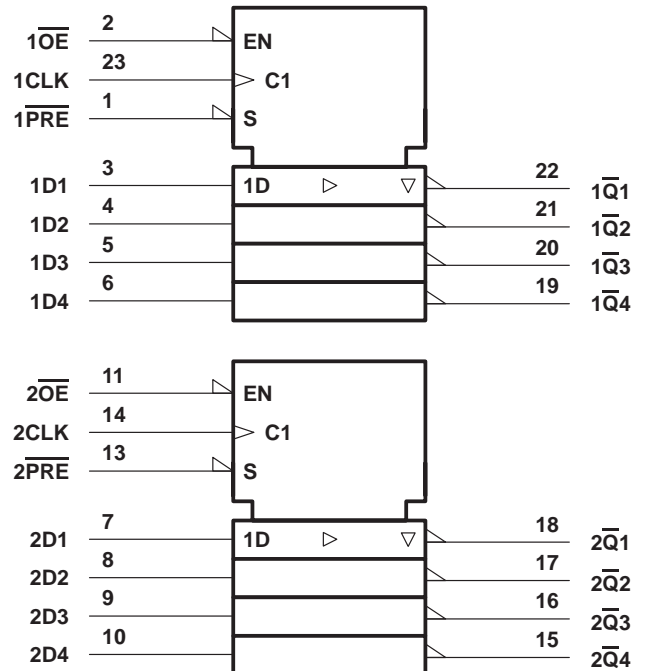

† These symbols are in accordance with ANSI/IEEE Std 91-1984 and IEC Publication 617-12. Pin numbers shown are for the DW, JT, and NT packages.

**logic diagrams (positive logic)**

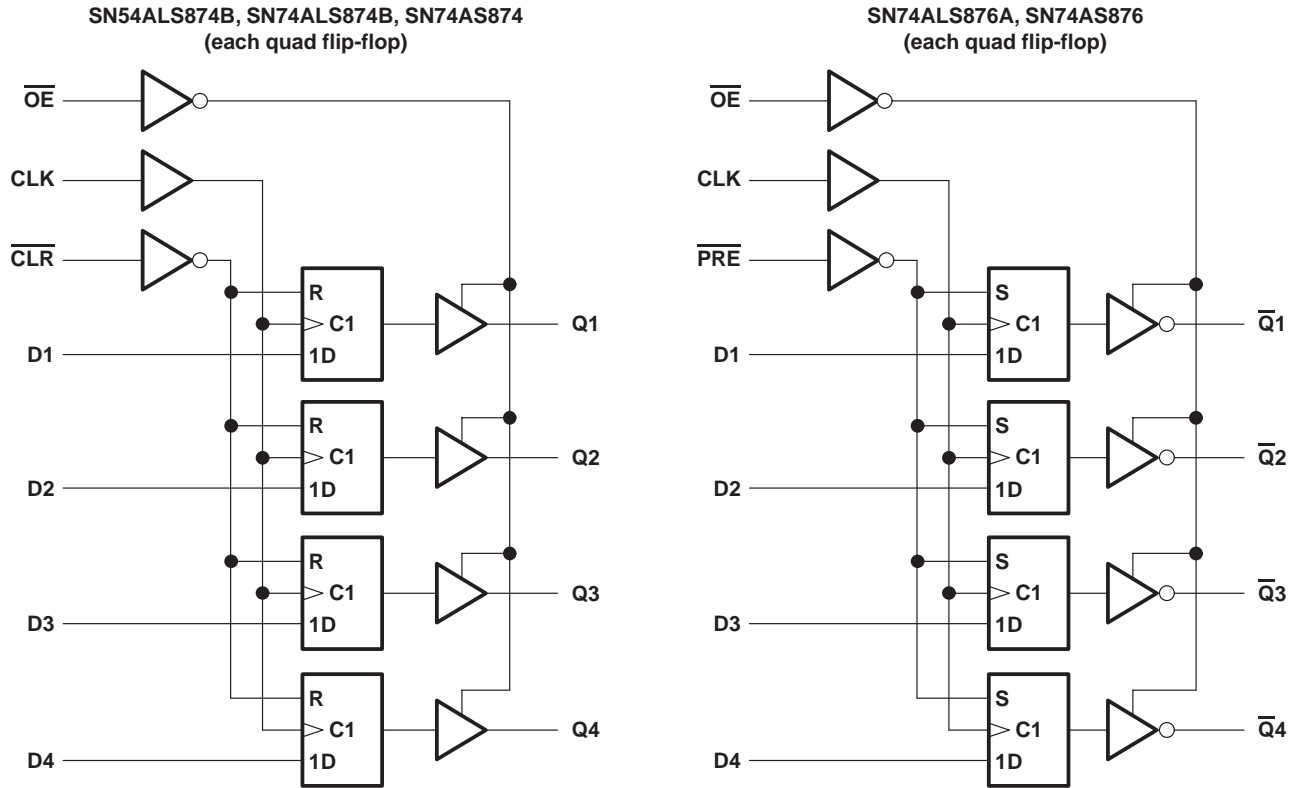

Pin numbers shown are for the DW, JT, and NT packages.

**absolute maximum ratings over operating free-air temperature range (unless otherwise noted)†**

Supply voltage, $V_{CC}$ .....	7 V
Input voltage, $V_I$ .....	7 V
Voltage applied to a disabled 3-state output .....	5.5 V
Operating free-air temperature range, $T_A$ : SN54ALS874B .....	-55°C to 125°C
SN74ALS874B, SN74ALS876A .....	0°C to 70°C
Storage temperature range .....	-65°C to 150°C

† Stresses beyond those listed under "absolute maximum ratings" may cause permanent damage to the device. These are stress ratings only, and functional operation of the device at these or any other conditions beyond those indicated under "recommended operating conditions" is not implied. Exposure to absolute-maximum-rated conditions for extended periods may affect device reliability.

**SN54ALS874B, SN74ALS874B, SN74ALS876A  
SN74AS874, SN74AS876  
DUAL 4-BIT D-TYPE EDGE-TRIGGERED FLIP-FLOPS**

SDAS061C – APRIL 1982 – REVISED JANUARY 1995

**recommended operating conditions**

		SN54ALS874B			SN74ALS874B SN74ALS876A			UNIT
		MIN	NOM	MAX	MIN	NOM	MAX	
V <sub>CC</sub>	Supply voltage	4.5	5	5.5	4.5	5	5.5	V
V <sub>IH</sub>	High-level input voltage	2			2			V
V <sub>IL</sub>	Low-level input voltage			0.7			0.8	V
I <sub>OH</sub>	High-level output current			-1			-2.6	mA
I <sub>OL</sub>	Low-level output current			12			24	mA
f <sub>clock</sub>	Clock frequency	0		25	0		30	MHz
t <sub>w</sub>	Pulse duration	PRE or CLR low		15		10		ns
		CLK high		20		16.5		
		CLK low		20		16.5		
t <sub>su</sub>	Setup time before CLK↑	Data		15		15		ns
		PRE or CLR inactive		15		10		
t <sub>h</sub>	Hold time, data after CLK↑	4			0			ns
T <sub>A</sub>	Operating free-air temperature	-55		125	0		70	°C

**electrical characteristics over recommended operating free-air temperature range (unless otherwise noted)**

PARAMETER		TEST CONDITIONS		SN54ALS874B			SN74ALS874B SN74ALS876A			UNIT
				MIN	TYP†	MAX	MIN	TYP†	MAX	
V <sub>IK</sub>		V <sub>CC</sub> = 4.5 V,	I <sub>I</sub> = -18 mA			-1.2			-1.2	V
V <sub>OH</sub>		V <sub>CC</sub> = 4.5 V to 5.5 V,		I <sub>OH</sub> = -0.4 mA	V <sub>CC</sub> - 2		V <sub>CC</sub> - 2			V
		V <sub>CC</sub> = 4.5 V		I <sub>OH</sub> = -1 mA	2.4	3.3				
				I <sub>OH</sub> = -2.6 mA			2.4	3.2		
V <sub>OL</sub>		V <sub>CC</sub> = 4.5 V		I <sub>OL</sub> = 12 mA	0.25	0.4	0.25	0.4		V
				I <sub>OL</sub> = 24 mA			0.35	0.5		
I <sub>OZH</sub>		V <sub>CC</sub> = 5.5 V,	V <sub>O</sub> = 2.7 V			20		20		μA
I <sub>OZL</sub>		V <sub>CC</sub> = 5.5 V,	V <sub>O</sub> = 0.4 V			-20		-20		μA
I <sub>I</sub>		V <sub>CC</sub> = 5.5 V,	V <sub>I</sub> = 7 V			0.1		0.1		mA
I <sub>IH</sub>		V <sub>CC</sub> = 5.5 V,	V <sub>I</sub> = 2.7 V			20		20		μA
I <sub>IL</sub>		V <sub>CC</sub> = 5.5 V,	V <sub>I</sub> = 0.4 V			-0.2		-0.2		mA
I <sub>O‡</sub>		V <sub>CC</sub> = 5.5 V,	V <sub>O</sub> = 2.25 V	-20		-112	-30		-112	mA
I <sub>CC</sub>	'ALS874B	V <sub>CC</sub> = 5.5 V		Outputs high		14	21	14	21	mA
				Outputs low		19	30	19	30	
				Outputs disabled		20	32	20	32	
	SN74ALS876A	V <sub>CC</sub> = 5.5 V		Outputs high				14	21	
				Outputs low				18	29	
				Outputs disabled				20	31	

† All typical values are at V<sub>CC</sub> = 5 V, T<sub>A</sub> = 25°C.

‡ The output conditions have been chosen to produce a current that closely approximates one half of the true short-circuit output current, I<sub>OS</sub>.



SN54ALS874B, SN74ALS874B, SN74ALS876A  
 SN74AS874, SN74AS876  
 DUAL 4-BIT D-TYPE EDGE-TRIGGERED FLIP-FLOPS  
 SDAS061C – APRIL 1982 – REVISED JANUARY 1995

**switching characteristics (see Figure 1)**

PARAMETER	FROM (INPUT)	TO (OUTPUT)	V <sub>CC</sub> = 4.5 V to 5.5 V, C <sub>L</sub> = 50 pF, R <sub>1</sub> = 500 Ω, R <sub>2</sub> = 500 Ω, T <sub>A</sub> = MIN to MAX†				UNIT
			SN54ALS874B		SN74ALS874B		
			MIN	MAX	MIN	MAX	
f <sub>max</sub>			25		30		MHz
t <sub>PLH</sub>	CLK	Any Q	4	18	4	14	ns
t <sub>PHL</sub>			4	16	4	14	
t <sub>PHL</sub>	$\overline{\text{CLR}}$	Any Q	5	23	5	17	ns
t <sub>PZH</sub>	$\overline{\text{OE}}$	Any Q	4	24	4	18	ns
t <sub>PZL</sub>			4	21	4	18	
t <sub>PHZ</sub>	$\overline{\text{OE}}$	Any Q	2	15	2	10	ns
t <sub>PLZ</sub>			3	22	3	12	

† For conditions shown as MIN or MAX, use the appropriate value specified under recommended operating conditions.

**switching characteristics (see Figure 1)**

PARAMETER	FROM (INPUT)	TO (OUTPUT)	V <sub>CC</sub> = 4.5 V to 5.5 V, C <sub>L</sub> = 50 pF, R <sub>1</sub> = 500 Ω, R <sub>2</sub> = 500 Ω, T <sub>A</sub> = MIN to MAX†		UNIT
			SN74ALS876A		
			MIN	MAX	
f <sub>max</sub>			30		MHz
t <sub>PLH</sub>	CLK	Any $\overline{\text{Q}}$	4	14	ns
t <sub>PHL</sub>			4	14	
t <sub>PHL</sub>	$\overline{\text{PRE}}$	Any $\overline{\text{Q}}$	6	19	ns
t <sub>PZH</sub>	$\overline{\text{OE}}$	Any $\overline{\text{Q}}$	4	18	ns
t <sub>PZL</sub>			4	18	
t <sub>PHZ</sub>	$\overline{\text{OE}}$	Any $\overline{\text{Q}}$	2	10	ns
t <sub>PLZ</sub>			3	13	

† For conditions shown as MIN or MAX, use the appropriate value specified under recommended operating conditions.

**absolute maximum ratings over operating free-air temperature range (unless otherwise noted)‡**

Supply voltage, V <sub>CC</sub>	7 V
Input voltage, V <sub>I</sub>	7 V
Operating free-air temperature range, T <sub>A</sub> : SN74AS874, SN74AS876	0°C to 70°C
Storage temperature range	-65°C to 150°C

‡ Stresses beyond those listed under “absolute maximum ratings” may cause permanent damage to the device. These are stress ratings only, and functional operation of the device at these or any other conditions beyond those indicated under “recommended operating conditions” is not implied. Exposure to absolute-maximum-rated conditions for extended periods may affect device reliability.



**SN54ALS874B, SN74ALS874B, SN74ALS876A**  
**SN74AS874, SN74AS876**  
**DUAL 4-BIT D-TYPE EDGE-TRIGGERED FLIP-FLOPS**

SDAS061C – APRIL 1982 – REVISED JANUARY 1995

**recommended operating conditions**

		SN74AS874			SN74AS876			UNIT
		MIN	NOM	MAX	MIN	NOM	MAX	
$V_{CC}$	Supply voltage	4.5	5	5.5	4.5	5	5.5	V
$V_{IH}$	High-level input voltage	2			2			V
$V_{IL}$	Low-level input voltage			0.8			0.8	V
$I_{OH}$	High-level output current			-15			-15	mA
$I_{OL}$	Low-level output current			48			48	mA
$f_{clock}$	Clock frequency	0		125	0		80	MHz
$t_w$	Pulse duration	$\overline{PRE}$ or $\overline{CLR}$ low		2		4.5		ns
		CLK high		3		6.2		
		CLK low		4		6.2		
$t_{su}$	Setup time before CLK $\uparrow$	Data		2		4.5		ns
		$\overline{PRE}$ or $\overline{CLR}$ inactive		4		5		
$t_h$	Hold time, data after CLK $\uparrow$	1			2			ns
$T_A$	Operating free-air temperature	0		70	0		70	$^{\circ}$ C

**electrical characteristics over recommended operating free-air temperature range (unless otherwise noted)**

PARAMETER		TEST CONDITIONS		SN74AS874 SN74AS876		UNIT
				MIN	TYP $\dagger$	
$V_{IK}$		$V_{CC} = 4.5\text{ V}$ ,	$I_I = -18\text{ mA}$		-1.2	V
$V_{OH}$		$V_{CC} = 4.5\text{ V to } 5.5\text{ V}$ ,	$I_{OH} = -2\text{ mA}$	$V_{CC} - 2$		V
		$V_{CC} = 4.5\text{ V}$ ,	$I_{OH} = -15\text{ mA}$	2.4	3.3	
$V_{OL}$		$V_{CC} = 4.5\text{ V}$ ,	$I_{OL} = 48\text{ mA}$	0.35	0.5	V
$I_{OZH}$		$V_{CC} = 5.5\text{ V}$ ,	$V_O = 2.7\text{ V}$		50	$\mu$ A
$I_{OZL}$		$V_{CC} = 5.5\text{ V}$ ,	$V_O = 0.4\text{ V}$		-50	$\mu$ A
$I_I$		$V_{CC} = 5.5\text{ V}$ ,	$V_I = 7\text{ V}$		0.1	mA
$I_{IH}$		$V_{CC} = 5.5\text{ V}$ ,	$V_I = 2.7\text{ V}$		20	$\mu$ A
$I_{IL}$	D	$V_{CC} = 5.5\text{ V}$ ,	$V_I = 0.4\text{ V}$		-2	mA
	All others				-0.5	
$I_{O\ddagger}$		$V_{CC} = 5.5\text{ V}$ ,	$V_O = 2.25\text{ V}$	-30	-112	mA
$I_{CC}$	SN74AS874	$V_{CC} = 5.5\text{ V}$	Outputs high	82	133	mA
			Outputs low	92	149	
			Outputs disabled	100	160	
	SN74AS876		Outputs high	88	142	
			Outputs low	94	150	
			Outputs disabled	100	160	

$\dagger$  All typical values are at  $V_{CC} = 5\text{ V}$ ,  $T_A = 25^{\circ}\text{C}$ .

$\ddagger$  The output conditions have been chosen to produce a current that closely approximates one half of the true short-circuit output current,  $I_{OS}$ .



**SN54ALS874B, SN74ALS874B, SN74ALS876A**  
**SN74AS874, SN74AS876**  
**DUAL 4-BIT D-TYPE EDGE-TRIGGERED FLIP-FLOPS**  
SDAS061C – APRIL 1982 – REVISED JANUARY 1995

**switching characteristics (see Figure 1)**

PARAMETER	FROM (INPUT)	TO (OUTPUT)	V <sub>CC</sub> = 4.5 V to 5.5 V, C <sub>L</sub> = 50 pF, R <sub>1</sub> = 500 Ω, R <sub>2</sub> = 500 Ω, T <sub>A</sub> = MIN to MAX†		UNIT
			SN74AS874		
			MIN	MAX	
f <sub>max</sub>			125		MHz
t <sub>PLH</sub>	CLK	Any Q	3	8.5	ns
t <sub>PHL</sub>			4	10.5	
t <sub>PHL</sub>	$\overline{\text{CLR}}$	Any Q	4	9.5	ns
t <sub>PZH</sub>	$\overline{\text{OE}}$	Any Q	2	7	ns
t <sub>PZL</sub>			3	10.5	
t <sub>PHZ</sub>	$\overline{\text{OE}}$	Any Q	2	6	ns
t <sub>PLZ</sub>			2	7.5	

† For conditions shown as MIN or MAX, use the appropriate value specified under recommended operating conditions.

**switching characteristics (see Figure 1)**

PARAMETER	FROM (INPUT)	TO (OUTPUT)	V <sub>CC</sub> = 4.5 V to 5.5 V, C <sub>L</sub> = 50 pF, R <sub>1</sub> = 500 Ω, R <sub>2</sub> = 500 Ω, T <sub>A</sub> = MIN to MAX†		UNIT
			SN74AS876		
			MIN	MAX	
f <sub>max</sub>			80		MHz
t <sub>PLH</sub>	CLK	Any $\overline{\text{Q}}$	3	8.5	ns
t <sub>PHL</sub>			4	10.5	
t <sub>PHL</sub>	$\overline{\text{PRE}}$	Any $\overline{\text{Q}}$	4	9.5	ns
t <sub>PZH</sub>	$\overline{\text{OE}}$	Any $\overline{\text{Q}}$	2	7	ns
t <sub>PZL</sub>			3	11	
t <sub>PHZ</sub>	$\overline{\text{OE}}$	Any $\overline{\text{Q}}$	2	7	ns
t <sub>PLZ</sub>			2	7	

† For conditions shown as MIN or MAX, use the appropriate value specified under recommended operating conditions.

PARAMETER MEASUREMENT INFORMATION  
 SERIES 54ALS/74ALS AND 54AS/74AS DEVICES

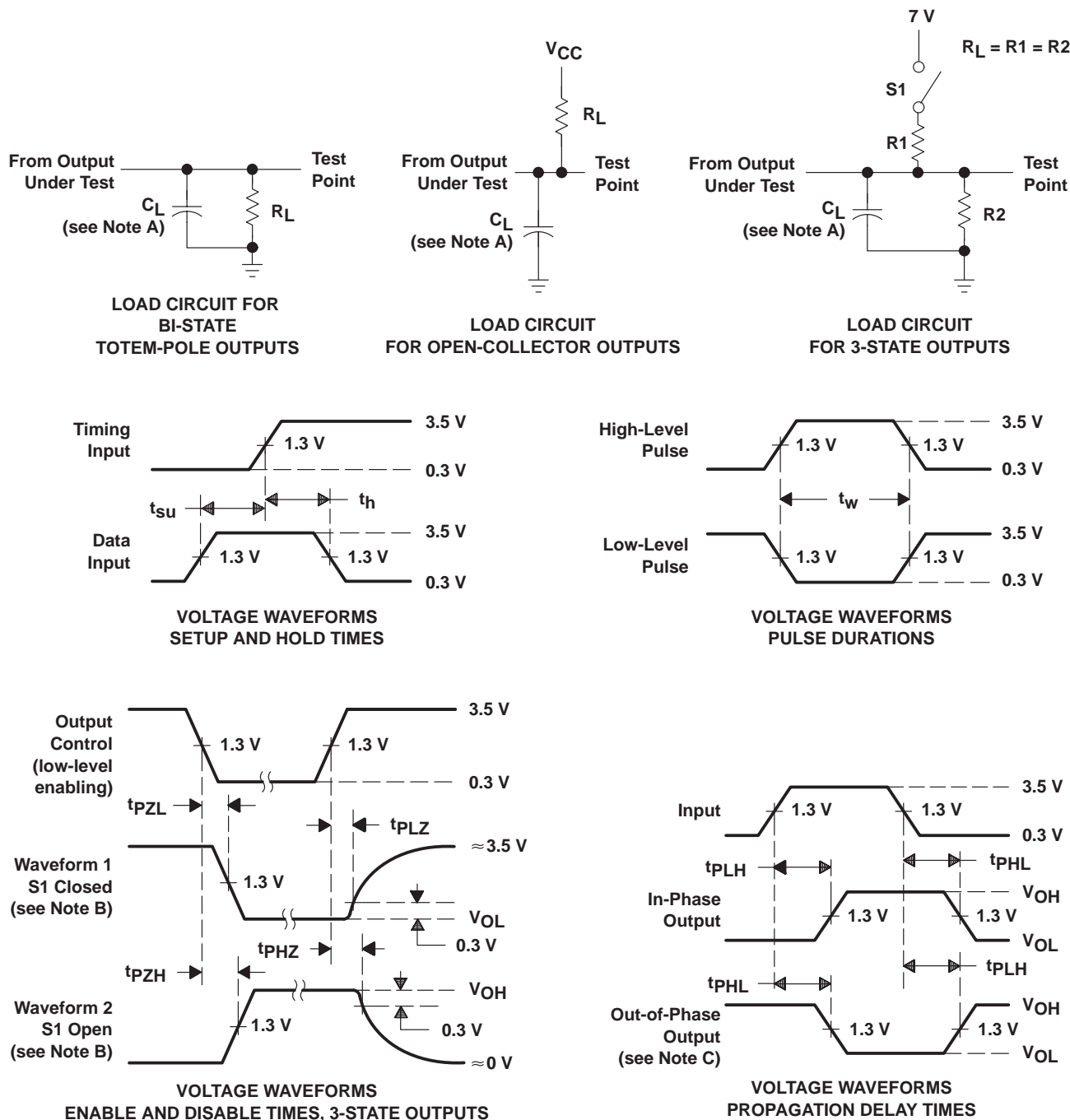

- NOTES: A.  $C_L$  includes probe and jig capacitance.  
 B. Waveform 1 is for an output with internal conditions such that the output is low except when disabled by the output control. Waveform 2 is for an output with internal conditions such that the output is high except when disabled by the output control.  
 C. When measuring propagation delay items of 3-state outputs, switch S1 is open.  
 D. All input pulses have the following characteristics:  $PRR \leq 1$  MHz,  $t_r = t_f = 2$  ns, duty cycle = 50%.  
 E. The outputs are measured one at a time with one transition per measurement.

Figure 1. Load Circuits and Voltage Waveforms

**PACKAGING INFORMATION**

Orderable Device	Status <sup>(1)</sup>	Package Type	Package Drawing	Pins	Package Qty	Eco Plan <sup>(2)</sup>	Lead/Ball Finish	MSL Peak Temp <sup>(3)</sup>
84010013A	ACTIVE	LCCC	FK	28	1	TBD	POST-PLATE	N / A for Pkg Type
8401001KA	OBSOLETE	CFP	W	24		TBD	Call TI	Call TI
8401001LA	ACTIVE	CDIP	JT	24	1	TBD	A42 SNPB	N / A for Pkg Type
SN54ALS874BJT	ACTIVE	CDIP	JT	24	1	TBD	A42 SNPB	N / A for Pkg Type
SN74ALS874BDW	ACTIVE	SOIC	DW	24	25	Green (RoHS & no Sb/Br)	CU NIPDAU	Level-1-260C-UNLIM
SN74ALS874BDWE4	ACTIVE	SOIC	DW	24	25	Green (RoHS & no Sb/Br)	CU NIPDAU	Level-1-260C-UNLIM
SN74ALS874BDWG4	ACTIVE	SOIC	DW	24	25	Green (RoHS & no Sb/Br)	CU NIPDAU	Level-1-260C-UNLIM
SN74ALS874BDWR	ACTIVE	SOIC	DW	24	2000	Green (RoHS & no Sb/Br)	CU NIPDAU	Level-1-260C-UNLIM
SN74ALS874BDWRE4	ACTIVE	SOIC	DW	24	2000	Green (RoHS & no Sb/Br)	CU NIPDAU	Level-1-260C-UNLIM
SN74ALS874BDWRG4	ACTIVE	SOIC	DW	24	2000	Green (RoHS & no Sb/Br)	CU NIPDAU	Level-1-260C-UNLIM
SN74ALS874BNSR	ACTIVE	SO	NS	24	2000	Green (RoHS & no Sb/Br)	CU NIPDAU	Level-1-260C-UNLIM
SN74ALS874BNSRE4	ACTIVE	SO	NS	24	2000	Green (RoHS & no Sb/Br)	CU NIPDAU	Level-1-260C-UNLIM
SN74ALS874BNT	ACTIVE	PDIP	NT	24	15	Pb-Free (RoHS)	CU NIPDAU	N / A for Pkg Type
SN74ALS874BNTE4	ACTIVE	PDIP	NT	24	15	Pb-Free (RoHS)	CU NIPDAU	N / A for Pkg Type
SN74ALS876ADW	ACTIVE	SOIC	DW	24	25	Green (RoHS & no Sb/Br)	CU NIPDAU	Level-1-260C-UNLIM
SN74ALS876ADWE4	ACTIVE	SOIC	DW	24	25	Green (RoHS & no Sb/Br)	CU NIPDAU	Level-1-260C-UNLIM
SN74ALS876ADWR	ACTIVE	SOIC	DW	24	2000	Green (RoHS & no Sb/Br)	CU NIPDAU	Level-1-260C-UNLIM
SN74ALS876ADWRE4	ACTIVE	SOIC	DW	24	2000	Green (RoHS & no Sb/Br)	CU NIPDAU	Level-1-260C-UNLIM
SN74ALS876ANT	ACTIVE	PDIP	NT	24	15	Pb-Free (RoHS)	CU NIPDAU	N / A for Pkg Type
SN74ALS876ANTE4	ACTIVE	PDIP	NT	24	15	Pb-Free (RoHS)	CU NIPDAU	N / A for Pkg Type
SN74AS874DW	ACTIVE	SOIC	DW	24	25	Green (RoHS & no Sb/Br)	CU NIPDAU	Level-1-260C-UNLIM
SN74AS874DWE4	ACTIVE	SOIC	DW	24	25	Green (RoHS & no Sb/Br)	CU NIPDAU	Level-1-260C-UNLIM
SN74AS874DWR	ACTIVE	SOIC	DW	24	2000	Green (RoHS & no Sb/Br)	CU NIPDAU	Level-1-260C-UNLIM
SN74AS874DWRE4	ACTIVE	SOIC	DW	24	2000	Green (RoHS & no Sb/Br)	CU NIPDAU	Level-1-260C-UNLIM
SN74AS874NT	ACTIVE	PDIP	NT	24	15	Pb-Free (RoHS)	CU NIPDAU	N / A for Pkg Type
SN74AS874NTE4	ACTIVE	PDIP	NT	24	15	Pb-Free (RoHS)	CU NIPDAU	N / A for Pkg Type
SN74AS876DW	ACTIVE	SOIC	DW	24	25	Green (RoHS & no Sb/Br)	CU NIPDAU	Level-1-260C-UNLIM

Orderable Device	Status <sup>(1)</sup>	Package Type	Package Drawing	Pins	Package Qty	Eco Plan <sup>(2)</sup>	Lead/Ball Finish	MSL Peak Temp <sup>(3)</sup>
						no Sb/Br)		
SN74AS876DWE4	ACTIVE	SOIC	DW	24	25	Green (RoHS & no Sb/Br)	CU NIPDAU	Level-1-260C-UNLIM
SN74AS876DWR	ACTIVE	SOIC	DW	24	2000	Green (RoHS & no Sb/Br)	CU NIPDAU	Level-1-260C-UNLIM
SN74AS876DWRE4	ACTIVE	SOIC	DW	24	2000	Green (RoHS & no Sb/Br)	CU NIPDAU	Level-1-260C-UNLIM
SN74AS876NT	ACTIVE	PDIP	NT	24	15	Pb-Free (RoHS)	CU NIPDAU	N / A for Pkg Type
SN74AS876NTE4	ACTIVE	PDIP	NT	24	15	Pb-Free (RoHS)	CU NIPDAU	N / A for Pkg Type
SNJ54ALS874BFB	ACTIVE	LCCC	FK	28	1	TBD	POST-PLATE	N / A for Pkg Type
SNJ54ALS874BJT	ACTIVE	CDIP	JT	24	1	TBD	A42 SNPB	N / A for Pkg Type

<sup>(1)</sup> The marketing status values are defined as follows:

**ACTIVE:** Product device recommended for new designs.

**LIFEBUY:** TI has announced that the device will be discontinued, and a lifetime-buy period is in effect.

**NRND:** Not recommended for new designs. Device is in production to support existing customers, but TI does not recommend using this part in a new design.

**PREVIEW:** Device has been announced but is not in production. Samples may or may not be available.

**OBSOLETE:** TI has discontinued the production of the device.

<sup>(2)</sup> Eco Plan - The planned eco-friendly classification: Pb-Free (RoHS), Pb-Free (RoHS Exempt), or Green (RoHS & no Sb/Br) - please check <http://www.ti.com/productcontent> for the latest availability information and additional product content details.

**TBD:** The Pb-Free/Green conversion plan has not been defined.

**Pb-Free (RoHS):** TI's terms "Lead-Free" or "Pb-Free" mean semiconductor products that are compatible with the current RoHS requirements for all 6 substances, including the requirement that lead not exceed 0.1% by weight in homogeneous materials. Where designed to be soldered at high temperatures, TI Pb-Free products are suitable for use in specified lead-free processes.

**Pb-Free (RoHS Exempt):** This component has a RoHS exemption for either 1) lead-based flip-chip solder bumps used between the die and package, or 2) lead-based die adhesive used between the die and leadframe. The component is otherwise considered Pb-Free (RoHS compatible) as defined above.

**Green (RoHS & no Sb/Br):** TI defines "Green" to mean Pb-Free (RoHS compatible), and free of Bromine (Br) and Antimony (Sb) based flame retardants (Br or Sb do not exceed 0.1% by weight in homogeneous material)

<sup>(3)</sup> MSL, Peak Temp. -- The Moisture Sensitivity Level rating according to the JEDEC industry standard classifications, and peak solder temperature.

**Important Information and Disclaimer:**The information provided on this page represents TI's knowledge and belief as of the date that it is provided. TI bases its knowledge and belief on information provided by third parties, and makes no representation or warranty as to the accuracy of such information. Efforts are underway to better integrate information from third parties. TI has taken and continues to take reasonable steps to provide representative and accurate information but may not have conducted destructive testing or chemical analysis on incoming materials and chemicals. TI and TI suppliers consider certain information to be proprietary, and thus CAS numbers and other limited information may not be available for release.

In no event shall TI's liability arising out of such information exceed the total purchase price of the TI part(s) at issue in this document sold by TI to Customer on an annual basis.

JT (R-GDIP-T\*\*)

CERAMIC DUAL-IN-LINE

24 LEADS SHOWN

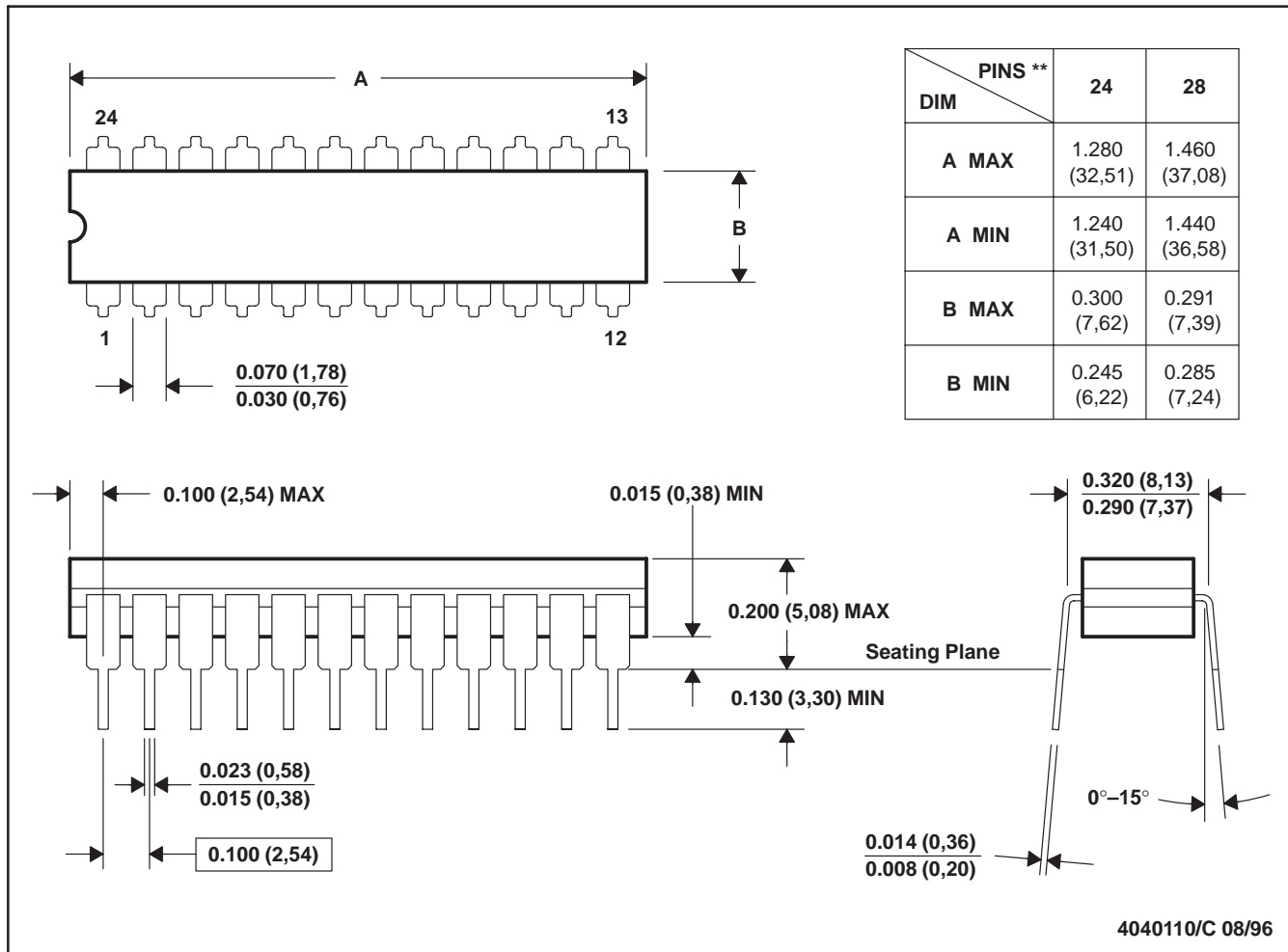

4040110/C 08/96

- NOTES: A. All linear dimensions are in inches (millimeters).  
 B. This drawing is subject to change without notice.  
 C. This package can be hermetically sealed with a ceramic lid using glass frit.  
 D. Index point is provided on cap for terminal identification.  
 E. Falls within MIL STD 1835 GDIP3-T24, GDIP4-T28, and JEDEC MO-058 AA, MO-058 AB

W (R-GDFP-F24)

CERAMIC DUAL FLATPACK

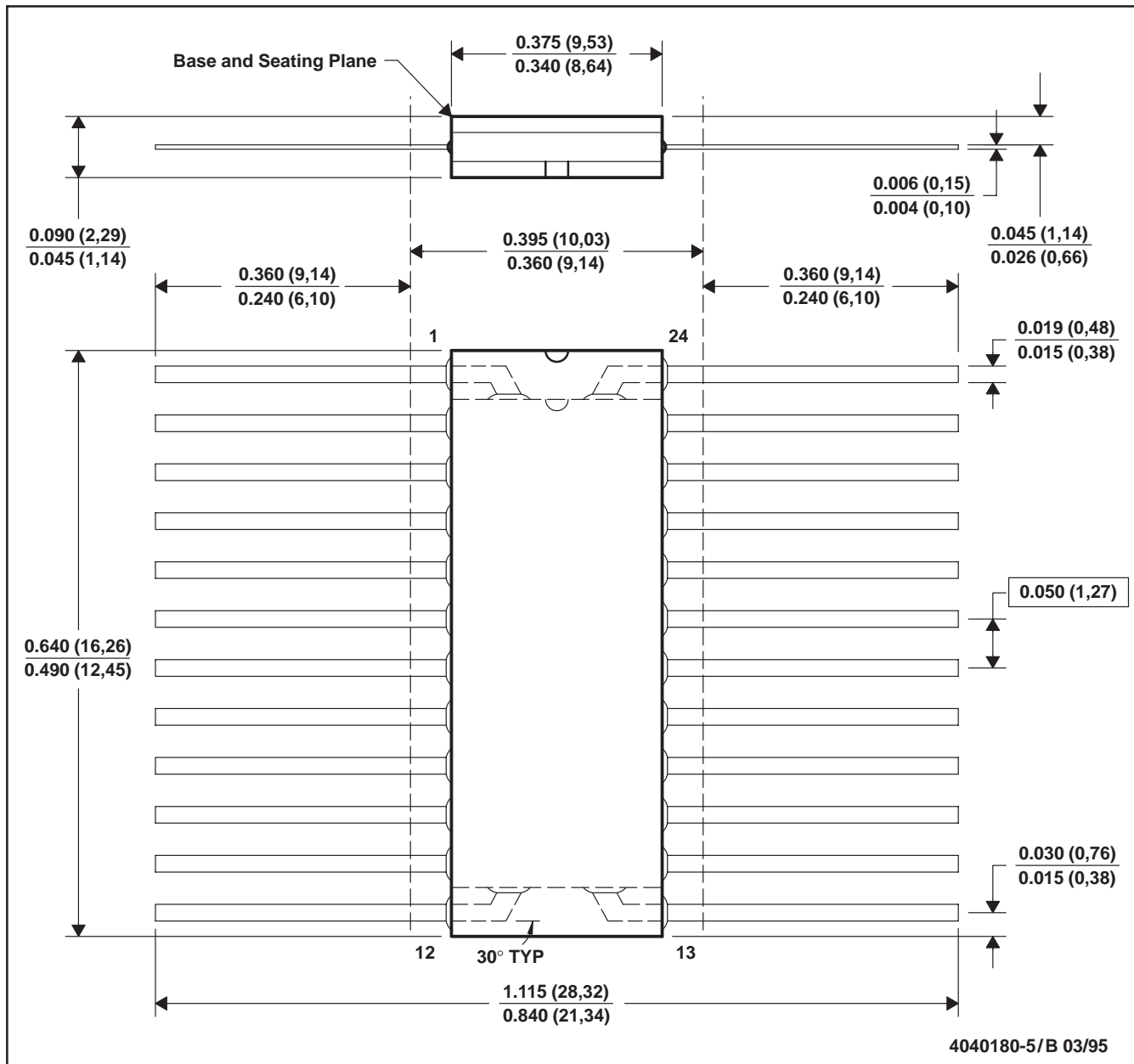

- NOTES:
- A. All linear dimensions are in inches (millimeters).
  - B. This drawing is subject to change without notice.
  - C. This package can be hermetically sealed with a ceramic lid using glass frit.
  - D. Falls within MIL-STD-1835 GDFP2-F24 and JEDEC MO-070AD
  - E. Index point is provided on cap for terminal identification only.

FK (S-CQCC-N\*\*)

LEADLESS CERAMIC CHIP CARRIER

28 TERMINAL SHOWN



4040140/D 10/96

- NOTES:
- A. All linear dimensions are in inches (millimeters).
  - B. This drawing is subject to change without notice.
  - C. This package can be hermetically sealed with a metal lid.
  - D. The terminals are gold plated.
  - E. Falls within JEDEC MS-004

NT (R-PDIP-T\*\*)

PLASTIC DUAL-IN-LINE PACKAGE

24 PINS SHOWN

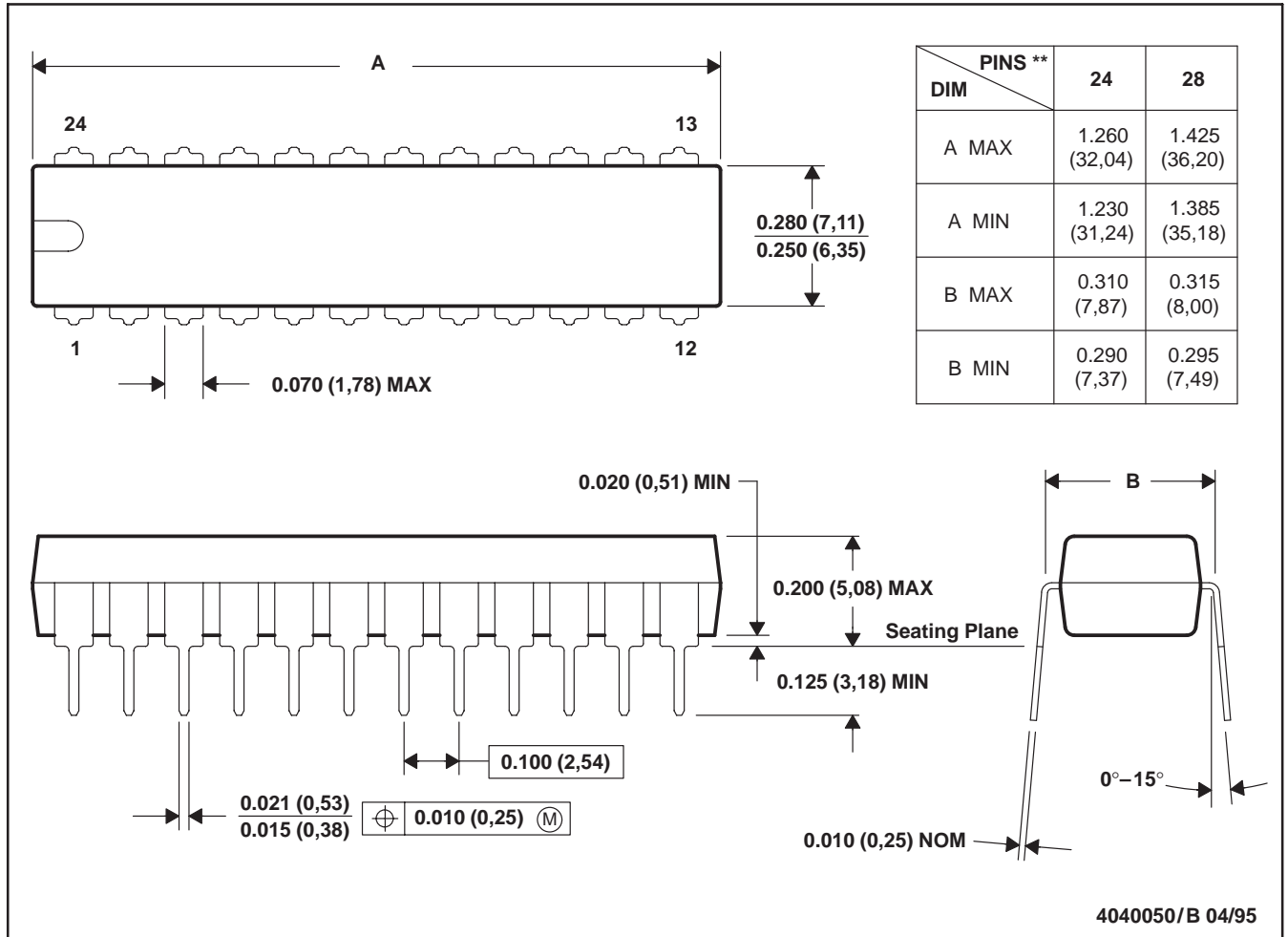

- NOTES: A. All linear dimensions are in inches (millimeters).  
 B. This drawing is subject to change without notice.

DW (R-PDSO-G24)

PLASTIC SMALL-OUTLINE PACKAGE

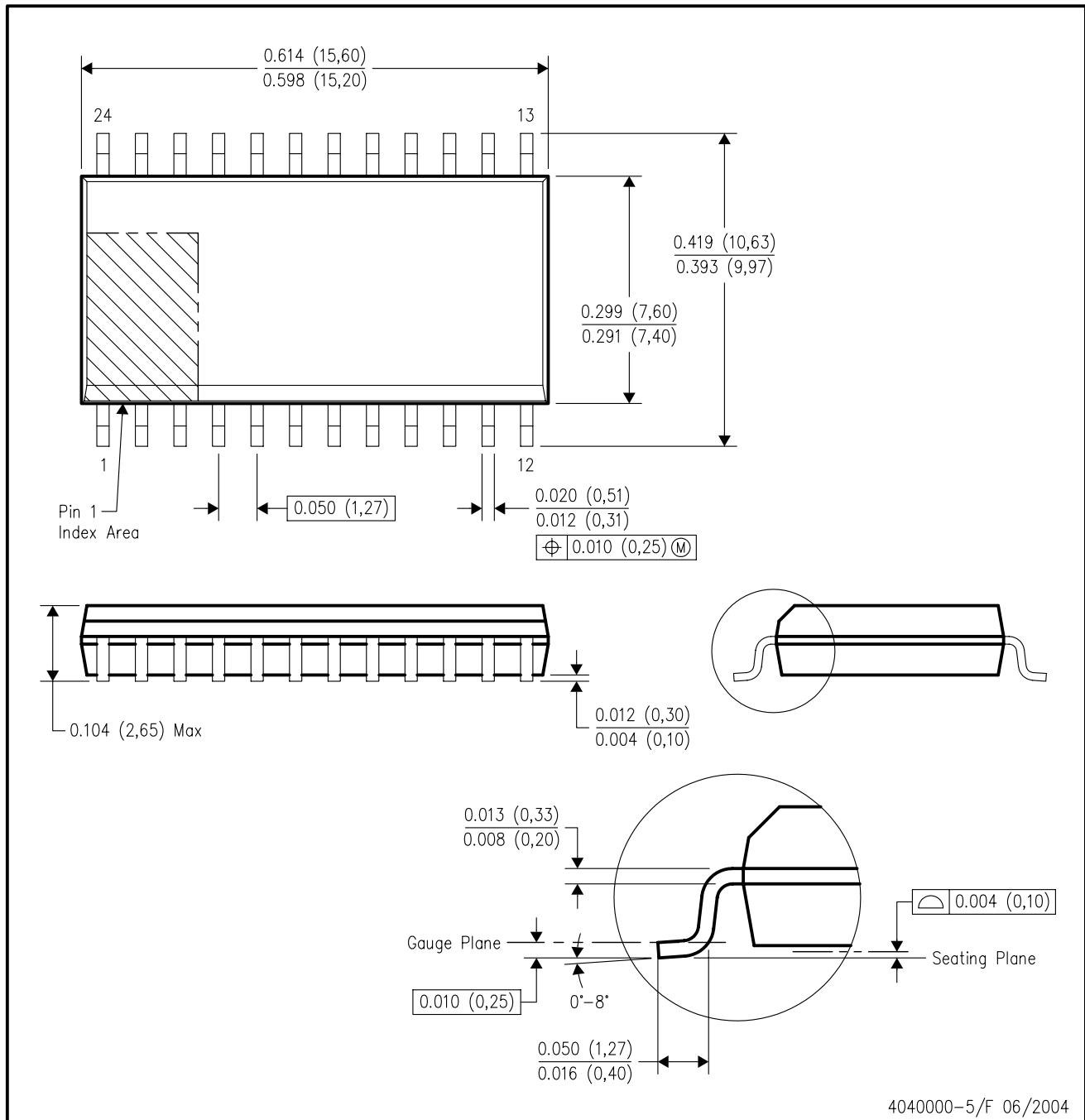

- NOTES:
- A. All linear dimensions are in inches (millimeters).
  - B. This drawing is subject to change without notice.
  - C. Body dimensions do not include mold flash or protrusion not to exceed 0.006 (0,15).
  - D. Falls within JEDEC MS-013 variation AD.

# MECHANICAL DATA

NS (R-PDSO-G\*\*)

PLASTIC SMALL-OUTLINE PACKAGE

14-PINS SHOWN



- NOTES:
- A. All linear dimensions are in millimeters.
  - B. This drawing is subject to change without notice.
  - C. Body dimensions do not include mold flash or protrusion, not to exceed 0,15.

## IMPORTANT NOTICE

Texas Instruments Incorporated and its subsidiaries (TI) reserve the right to make corrections, modifications, enhancements, improvements, and other changes to its products and services at any time and to discontinue any product or service without notice. Customers should obtain the latest relevant information before placing orders and should verify that such information is current and complete. All products are sold subject to TI's terms and conditions of sale supplied at the time of order acknowledgment.

TI warrants performance of its hardware products to the specifications applicable at the time of sale in accordance with TI's standard warranty. Testing and other quality control techniques are used to the extent TI deems necessary to support this warranty. Except where mandated by government requirements, testing of all parameters of each product is not necessarily performed.

TI assumes no liability for applications assistance or customer product design. Customers are responsible for their products and applications using TI components. To minimize the risks associated with customer products and applications, customers should provide adequate design and operating safeguards.

TI does not warrant or represent that any license, either express or implied, is granted under any TI patent right, copyright, mask work right, or other TI intellectual property right relating to any combination, machine, or process in which TI products or services are used. Information published by TI regarding third-party products or services does not constitute a license from TI to use such products or services or a warranty or endorsement thereof. Use of such information may require a license from a third party under the patents or other intellectual property of the third party, or a license from TI under the patents or other intellectual property of TI.

Reproduction of information in TI data books or data sheets is permissible only if reproduction is without alteration and is accompanied by all associated warranties, conditions, limitations, and notices. Reproduction of this information with alteration is an unfair and deceptive business practice. TI is not responsible or liable for such altered documentation.

Resale of TI products or services with statements different from or beyond the parameters stated by TI for that product or service voids all express and any implied warranties for the associated TI product or service and is an unfair and deceptive business practice. TI is not responsible or liable for any such statements.

Following are URLs where you can obtain information on other Texas Instruments products and application solutions:

<b>Products</b>		<b>Applications</b>	
Amplifiers	<a href="http://amplifier.ti.com">amplifier.ti.com</a>	Audio	<a href="http://www.ti.com/audio">www.ti.com/audio</a>
Data Converters	<a href="http://dataconverter.ti.com">dataconverter.ti.com</a>	Automotive	<a href="http://www.ti.com/automotive">www.ti.com/automotive</a>
DSP	<a href="http://dsp.ti.com">dsp.ti.com</a>	Broadband	<a href="http://www.ti.com/broadband">www.ti.com/broadband</a>
Interface	<a href="http://interface.ti.com">interface.ti.com</a>	Digital Control	<a href="http://www.ti.com/digitalcontrol">www.ti.com/digitalcontrol</a>
Logic	<a href="http://logic.ti.com">logic.ti.com</a>	Military	<a href="http://www.ti.com/military">www.ti.com/military</a>
Power Mgmt	<a href="http://power.ti.com">power.ti.com</a>	Optical Networking	<a href="http://www.ti.com/opticalnetwork">www.ti.com/opticalnetwork</a>
Microcontrollers	<a href="http://microcontroller.ti.com">microcontroller.ti.com</a>	Security	<a href="http://www.ti.com/security">www.ti.com/security</a>
Low Power Wireless	<a href="http://www.ti.com/lpw">www.ti.com/lpw</a>	Telephony	<a href="http://www.ti.com/telephony">www.ti.com/telephony</a>
		Video & Imaging	<a href="http://www.ti.com/video">www.ti.com/video</a>
		Wireless	<a href="http://www.ti.com/wireless">www.ti.com/wireless</a>

Mailing Address: Texas Instruments  
Post Office Box 655303 Dallas, Texas 75265