

SN54AS823A, SN74AS823A, SN74AS824A 9-BIT BUS-INTERFACE FLIP-FLOPS WITH 3-STATE OUTPUTS

SDAS231A – JUNE 1984 – REVISED AUGUST 1995

- Functionally Equivalent to AMD's AM29823 and AM29824
- Provide Extra Data Width Necessary for Wider Address/Data Paths or Buses With Parity
- Outputs Have Undershoot-Protection Circuitry
- Power-Up High-Impedance State
- Buffered Control Inputs to Reduce dc Loading Effects
- Package Options Include Plastic Small-Outline (DW) Packages, Ceramic Chip Carriers (FK), and Standard Plastic (NT) and Ceramic (JT) 300-mil DIPs

description

These 9-bit flip-flops feature 3-state outputs designed specifically for driving highly capacitive or relatively low-impedance loads. These devices are particularly suitable for implementing wider buffer registers, I/O ports, bidirectional bus drivers, parity bus interfacing, and working registers.

With the clock-enable ($\overline{\text{CLKEN}}$) input low, the nine D-type edge-triggered flip-flops enter data on the low-to-high transitions of the clock (CLK) input. Taking $\overline{\text{CLKEN}}$ high disables the clock buffer, latching the outputs. The SN54AS823A and SN74AS823A have noninverting data (D) inputs and the SN74AS824A has inverting ($\overline{\text{D}}$) inputs. Taking the clear ($\overline{\text{CLR}}$) input low causes the nine Q outputs to go low independently of the clock.

A buffered output-enable ($\overline{\text{OE}}$) input can be used to place the nine outputs in either a normal logic state (high or low logic level) or the high-impedance state. In the high-impedance state, the outputs neither load nor drive the bus lines significantly. The high-impedance state and increased drive provide the capability to drive bus lines without interface or pullup components.

$\overline{\text{OE}}$ does not affect the internal operation of the flip-flops. Old data can be retained or new data can be entered while the outputs are in the high-impedance state.

The SN54AS823A is characterized for operation over the full military temperature range of -55°C to 125°C . The SN74AS823A and SN74AS824A are characterized for operation from 0°C to 70°C .

SN54AS823A . . . JT PACKAGE
SN74AS823A . . . DW OR NT PACKAGE
(TOP VIEW)

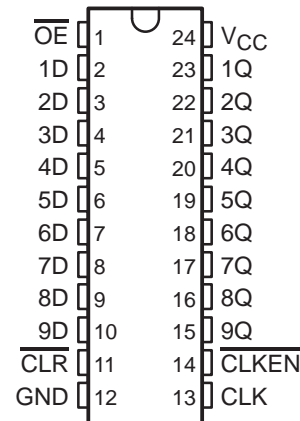

SN54AS823A . . . FK PACKAGE
(TOP VIEW)

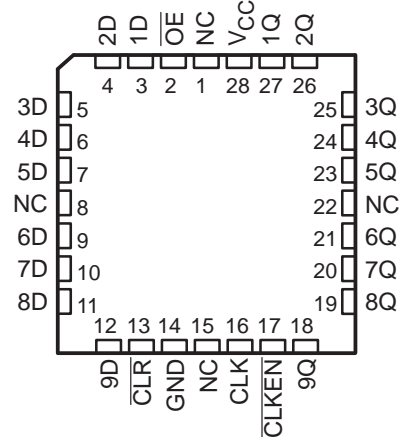

SN74AS824A . . . DW OR NT PACKAGE
(TOP VIEW)

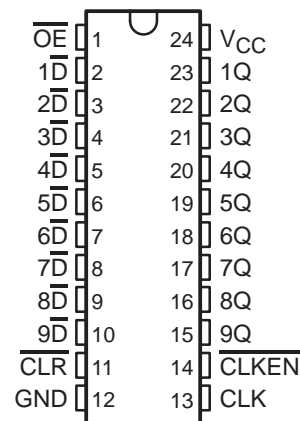

NC – No internal connection

PRODUCTION DATA information is current as of publication date. Products conform to specifications per the terms of Texas Instruments standard warranty. Production processing does not necessarily include testing of all parameters.

 **TEXAS
INSTRUMENTS**

POST OFFICE BOX 655303 • DALLAS, TEXAS 75265

Copyright © 1995, Texas Instruments Incorporated

SN54AS823A, SN74AS823A, SN74AS824A 9-BIT BUS-INTERFACE FLIP-FLOPS WITH 3-STATE OUTPUTS

SDAS231A – JUNE 1984 – REVISED AUGUST 1995

Function Tables

SN54AS823A, SN74AS823A
(each flip-flop)

INPUTS					OUTPUT Q
$\overline{\text{OE}}$	$\overline{\text{CLR}}$	$\overline{\text{CLKEN}}$	CLK	D	
L	L	X	X	X	L
L	H	L	↑	H	H
L	H	L	↑	L	L
L	H	H	X	X	Q_0
H	X	X	X	X	Z

SN74AS824A
(each flip-flop)

INPUTS					OUTPUT Q
$\overline{\text{OE}}$	$\overline{\text{CLR}}$	$\overline{\text{CLKEN}}$	CLK	$\overline{\text{D}}$	
L	L	X	X	X	L
L	H	L	↑	H	L
L	H	L	↑	L	H
L	H	H	X	X	Q_0
H	X	X	X	X	Z

logic symbol†

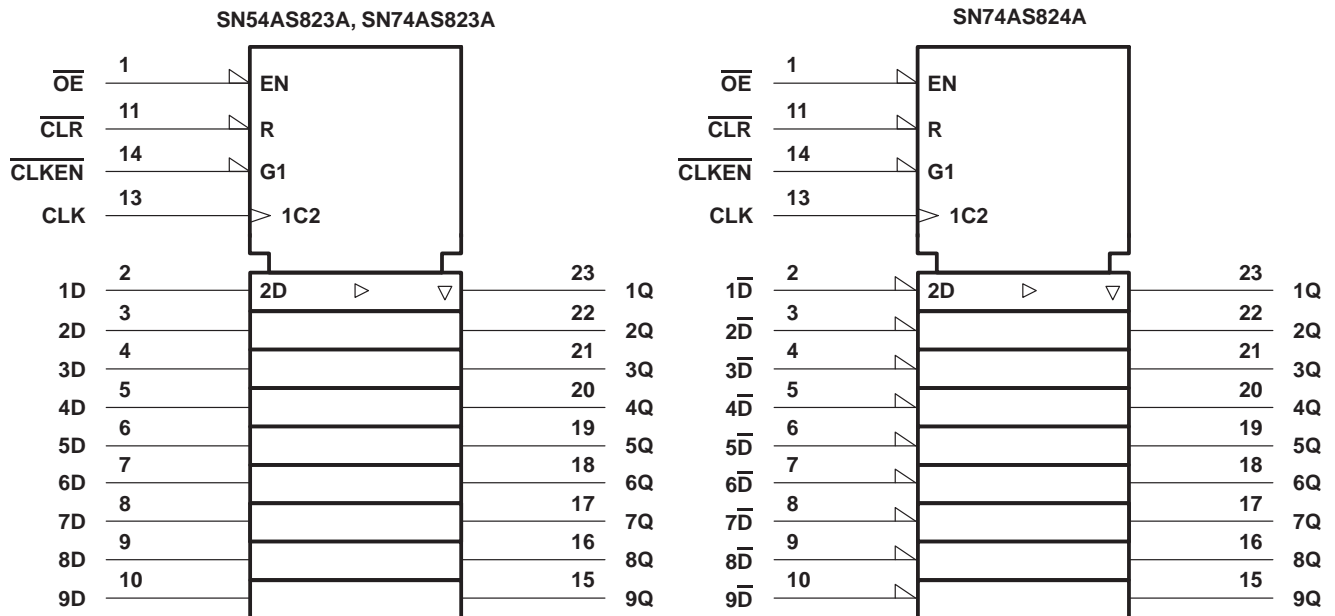

† These symbols are in accordance with ANSI/IEEE Std 91-1984 and IEC Publication 617-12. Pin numbers shown are for the DW, JT, and NT packages.

SN54AS823A, SN74AS823A, SN74AS824A
 9-BIT BUS-INTERFACE FLIP-FLOPS
 WITH 3-STATE OUTPUTS

SDAS231A – JUNE 1984 – REVISED AUGUST 1995

logic diagrams (positive logic)

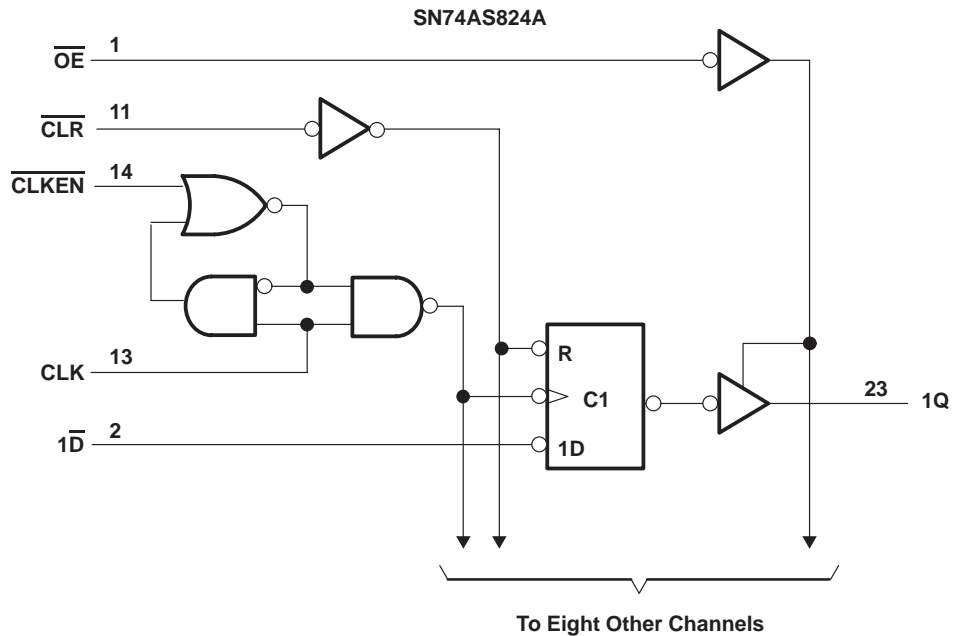
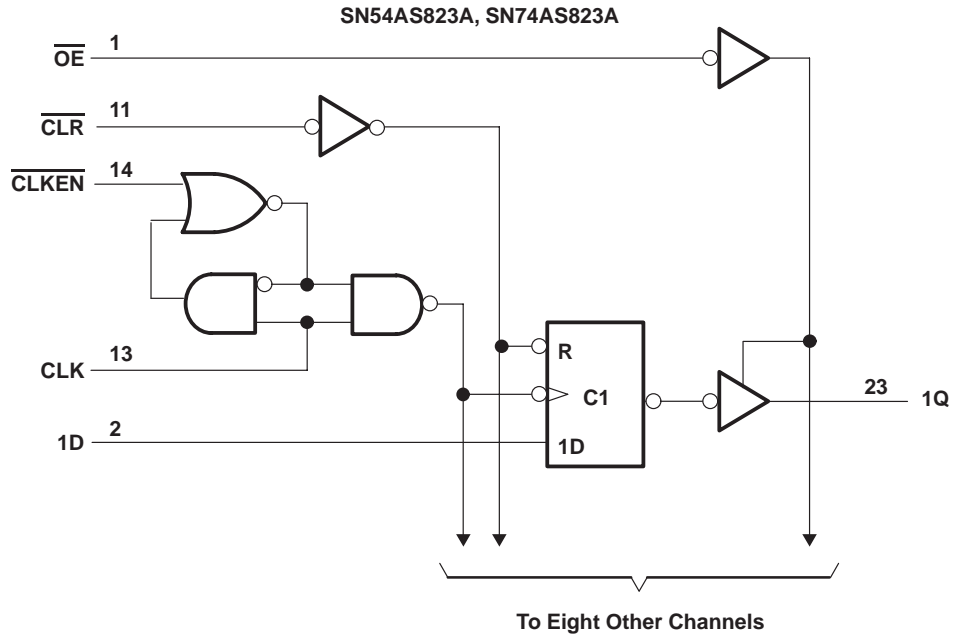

Pin numbers shown are for the DW, JT, and NT packages.

SN54AS823A, SN74AS823A, SN74AS824A 9-BIT BUS-INTERFACE FLIP-FLOPS WITH 3-STATE OUTPUTS

SDAS231A – JUNE 1984 – REVISED AUGUST 1995

absolute maximum ratings over operating free-air temperature range (unless otherwise noted)†

Supply voltage, V_{CC}	7 V
Input voltage, V_I	7 V
Voltage applied to a disabled 3-state output	5.5 V
Operating free-air temperature range, T_A : SN54AS823A	–55°C to 125°C
SN74AS823A, SN74AS824A	0°C to 70°C
Storage temperature range	–65°C to 150°C

† Stresses beyond those listed under “absolute maximum ratings” may cause permanent damage to the device. These are stress ratings only, and functional operation of the device at these or any other conditions beyond those indicated under “recommended operating conditions” is not implied. Exposure to absolute-maximum-rated conditions for extended periods may affect device reliability.

recommended operating conditions

		SN54AS823A			SN74AS823A SN74AS824A			UNIT
		MIN	NOM	MAX	MIN	NOM	MAX	
V_{CC}	Supply voltage	4.5	5	5.5	4.5	5	5.5	V
V_{IH}	High-level input voltage	2			2			V
V_{IL}	Low-level input voltage			0.8			0.8	V
I_{OH}	High-level output current			–24			–24	mA
I_{OL}	Low-level output current			32			48	mA
t_w^*	Pulse duration	CLR low	7.5		6.5			ns
		CLK high or low	9.5		8			
t_{su}^*	Setup time before CLK↑	CLR high	8		8			ns
		Data	7		6			
		CLKEN high or low	8.5		7.5			
t_h^*	Hold time after CLK↑			0			0	ns
T_A	Operating free-air temperature	–55		125	0		70	°C

* On products compliant to MIL-STD-883, Class B, this parameter is based on characterization data but is not production tested.

SN54AS823A, SN74AS823A, SN74AS824A 9-BIT BUS-INTERFACE FLIP-FLOPS WITH 3-STATE OUTPUTS

SDAS231A – JUNE 1984 – REVISED AUGUST 1995

electrical characteristics over recommended operating free-air temperature range (unless otherwise noted)

PARAMETER	TEST CONDITIONS		SN54AS823A			SN74AS823A SN74AS824A			UNIT
			MIN	TYP†	MAX	MIN	TYP†	MAX	
V_{IK}	$V_{CC} = 4.5\text{ V}$, $I_I = -18\text{ mA}$		-1.2			-1.2			V
V_{OH}	$V_{CC} = 4.5\text{ V to }5.5\text{ V}$, $I_{OH} = -2\text{ mA}$		$V_{CC} - 2$			$V_{CC} - 2$			V
	$V_{CC} = 4.5\text{ V}$	$I_{OH} = -15\text{ mA}$	2.4	3.2		2.4	3.2		
		$I_{OH} = -24\text{ mA}$	2			2			
V_{OL}	$V_{CC} = 4.5\text{ V}$	$I_{OL} = 32\text{ mA}$	0.3		0.5			V	
		$I_{OL} = 48\text{ mA}$					0.35		0.5
I_{OZH}	$V_{CC} = 5.5\text{ V}$,	$V_O = 2.7\text{ V}$	50			50			μA
I_{OZL}	$V_{CC} = 5.5\text{ V}$,	$V_I = 0.4\text{ V}$	-50			-50			μA
I_I	$V_{CC} = 5.5\text{ V}$,	$V_I = 7\text{ V}$	0.1			0.1			mA
I_{IH}	$V_{CC} = 5.5\text{ V}$,	$V_I = 2.7\text{ V}$	20			20			μA
I_{IL}	$V_{CC} = 5.5\text{ V}$,	$V_I = 0.4\text{ V}$	-0.5			-0.5			mA
$I_{O\ddagger}$	$V_{CC} = 5.5\text{ V}$,	$V_O = 2.25\text{ V}$	-30		-112	-30		-112	mA
I_{CC}	SN54AS823A, SN74AS823A	$V_{CC} = 5.5\text{ V}$	Outputs high	49	80	49	80	mA	
			Outputs low	61	100	61	100		
			Outputs disabled	64	103	64	103		
	SN74AS824A	$V_{CC} = 5.5\text{ V}$	Outputs high	49	80	49	80		
			Outputs low	61	100	61	100		
			Outputs disabled	64	103	64	103		

† All typical values are at $V_{CC} = 5\text{ V}$, $T_A = 25^\circ\text{C}$.

‡ The output conditions have been chosen to produce a current that closely approximates one half of the true short-circuit output current, I_{OS} .

switching characteristics (see Figure 1)

PARAMETER	FROM (INPUT)	TO (OUTPUT)	$V_{CC} = 4.5\text{ V to }5.5\text{ V}$, $C_L = 50\text{ pF}$, $R_1 = 500\ \Omega$, $R_2 = 500\ \Omega$, $T_A = \text{MIN to MAX}\S$				UNIT
			SN54AS823A		SN74AS823A SN74AS824A		
			MIN	MAX	MIN	MAX	
t_{PLH}	CLK	Any Q	3.5	9	3.5	7.5	ns
t_{PHL}			3.5	14	3.5	13	
t_{PHL}	$\overline{\text{CLR}}$	Any Q	3.5	16.5	3.5	15.5	ns
t_{PZH}	$\overline{\text{OE}}$	Any Q	4	12	4	11	ns
t_{PZL}			4	13	4	12	
t_{PHZ}	$\overline{\text{OE}}$	Any Q	1	10	1	8	ns
t_{PLZ}			1	10	1.5	8	

§ For conditions shown as MIN or MAX, use the appropriate value specified under recommended operating conditions.

SN54AS823A, SN74AS823A, SN74AS824A 9-BIT BUS-INTERFACE FLIP-FLOPS WITH 3-STATE OUTPUTS

SDAS231A – JUNE 1984 – REVISED AUGUST 1995

PARAMETER MEASUREMENT INFORMATION SERIES 54ALS/74ALS AND 54AS/74AS DEVICES



- NOTES: A. C_L includes probe and jig capacitance.
 B. Waveform 1 is for an output with internal conditions such that the output is low except when disabled by the output control. Waveform 2 is for an output with internal conditions such that the output is high except when disabled by the output control.
 C. When measuring propagation delay items of 3-state outputs, switch S1 is open.
 D. All input pulses have the following characteristics: $PRR \leq 1$ MHz, $t_r = t_f = 2$ ns, duty cycle = 50%.
 E. The outputs are measured one at a time with one transition per measurement.

Figure 1. Load Circuits and Voltage Waveforms

PACKAGING INFORMATION

Orderable Device	Status ⁽¹⁾	Package Type	Package Drawing	Pins	Package Qty	Eco Plan ⁽²⁾	Lead/Ball Finish	MSL Peak Temp ⁽³⁾	Samples (Requires Login)
5962-89525013A	ACTIVE	LCCC	FK	28	1	TBD	Call TI	Call TI	
5962-8952501KA	ACTIVE	CFP	W	24	1	TBD	Call TI	Call TI	
5962-8952501LA	ACTIVE	CDIP	JT	24	1	TBD	Call TI	Call TI	
SN74AS823ADW	NRND	SOIC	DW	24	25	Green (RoHS & no Sb/Br)	CU NIPDAU	Level-1-260C-UNLIM	
SN74AS823ADWE4	NRND	SOIC	DW	24	25	Green (RoHS & no Sb/Br)	CU NIPDAU	Level-1-260C-UNLIM	
SN74AS823ADWG4	NRND	SOIC	DW	24	25	Green (RoHS & no Sb/Br)	CU NIPDAU	Level-1-260C-UNLIM	
SN74AS823ANT	NRND	PDIP	NT	24	15	Pb-Free (RoHS)	CU NIPDAU	N / A for Pkg Type	
SN74AS823ANTE4	NRND	PDIP	NT	24	15	Pb-Free (RoHS)	CU NIPDAU	N / A for Pkg Type	
SN74AS824ADW	OBSOLETE	SOIC	DW	24		TBD	Call TI	Call TI	
SN74AS824ADWR	OBSOLETE	SOIC	DW	24		TBD	Call TI	Call TI	
SN74AS824ANT	OBSOLETE	PDIP	NT	24		TBD	Call TI	Call TI	
SNJ54AS823AFK	ACTIVE	LCCC	FK	28	1	TBD	POST-PLATE	N / A for Pkg Type	
SNJ54AS823AJT	ACTIVE	CDIP	JT	24	1	TBD	A42	N / A for Pkg Type	
SNJ54AS823AW	ACTIVE	CFP	W	24	1	TBD	A42	N / A for Pkg Type	

⁽¹⁾ The marketing status values are defined as follows:

ACTIVE: Product device recommended for new designs.

LIFEBUY: TI has announced that the device will be discontinued, and a lifetime-buy period is in effect.

NRND: Not recommended for new designs. Device is in production to support existing customers, but TI does not recommend using this part in a new design.

PREVIEW: Device has been announced but is not in production. Samples may or may not be available.

OBSOLETE: TI has discontinued the production of the device.

⁽²⁾ Eco Plan - The planned eco-friendly classification: Pb-Free (RoHS), Pb-Free (RoHS Exempt), or Green (RoHS & no Sb/Br) - please check <http://www.ti.com/productcontent> for the latest availability information and additional product content details.

TBD: The Pb-Free/Green conversion plan has not been defined.

Pb-Free (RoHS): TI's terms "Lead-Free" or "Pb-Free" mean semiconductor products that are compatible with the current RoHS requirements for all 6 substances, including the requirement that lead not exceed 0.1% by weight in homogeneous materials. Where designed to be soldered at high temperatures, TI Pb-Free products are suitable for use in specified lead-free processes.

Pb-Free (RoHS Exempt): This component has a RoHS exemption for either 1) lead-based flip-chip solder bumps used between the die and package, or 2) lead-based die adhesive used between the die and leadframe. The component is otherwise considered Pb-Free (RoHS compatible) as defined above.

Green (RoHS & no Sb/Br): TI defines "Green" to mean Pb-Free (RoHS compatible), and free of Bromine (Br) and Antimony (Sb) based flame retardants (Br or Sb do not exceed 0.1% by weight in homogeneous material)

⁽³⁾ MSL, Peak Temp. -- The Moisture Sensitivity Level rating according to the JEDEC industry standard classifications, and peak solder temperature.

Important Information and Disclaimer: The information provided on this page represents TI's knowledge and belief as of the date that it is provided. TI bases its knowledge and belief on information provided by third parties, and makes no representation or warranty as to the accuracy of such information. Efforts are underway to better integrate information from third parties. TI has taken and continues to take reasonable steps to provide representative and accurate information but may not have conducted destructive testing or chemical analysis on incoming materials and chemicals. TI and TI suppliers consider certain information to be proprietary, and thus CAS numbers and other limited information may not be available for release.

In no event shall TI's liability arising out of such information exceed the total purchase price of the TI part(s) at issue in this document sold by TI to Customer on an annual basis.

OTHER QUALIFIED VERSIONS OF SN54AS823A, SN74AS823A :

- Catalog: [SN74AS823A](#)
- Military: [SN54AS823A](#)

NOTE: Qualified Version Definitions:

- Catalog - TI's standard catalog product
- Military - QML certified for Military and Defense Applications

JT (R-GDIP-T**)

CERAMIC DUAL-IN-LINE

24 LEADS SHOWN

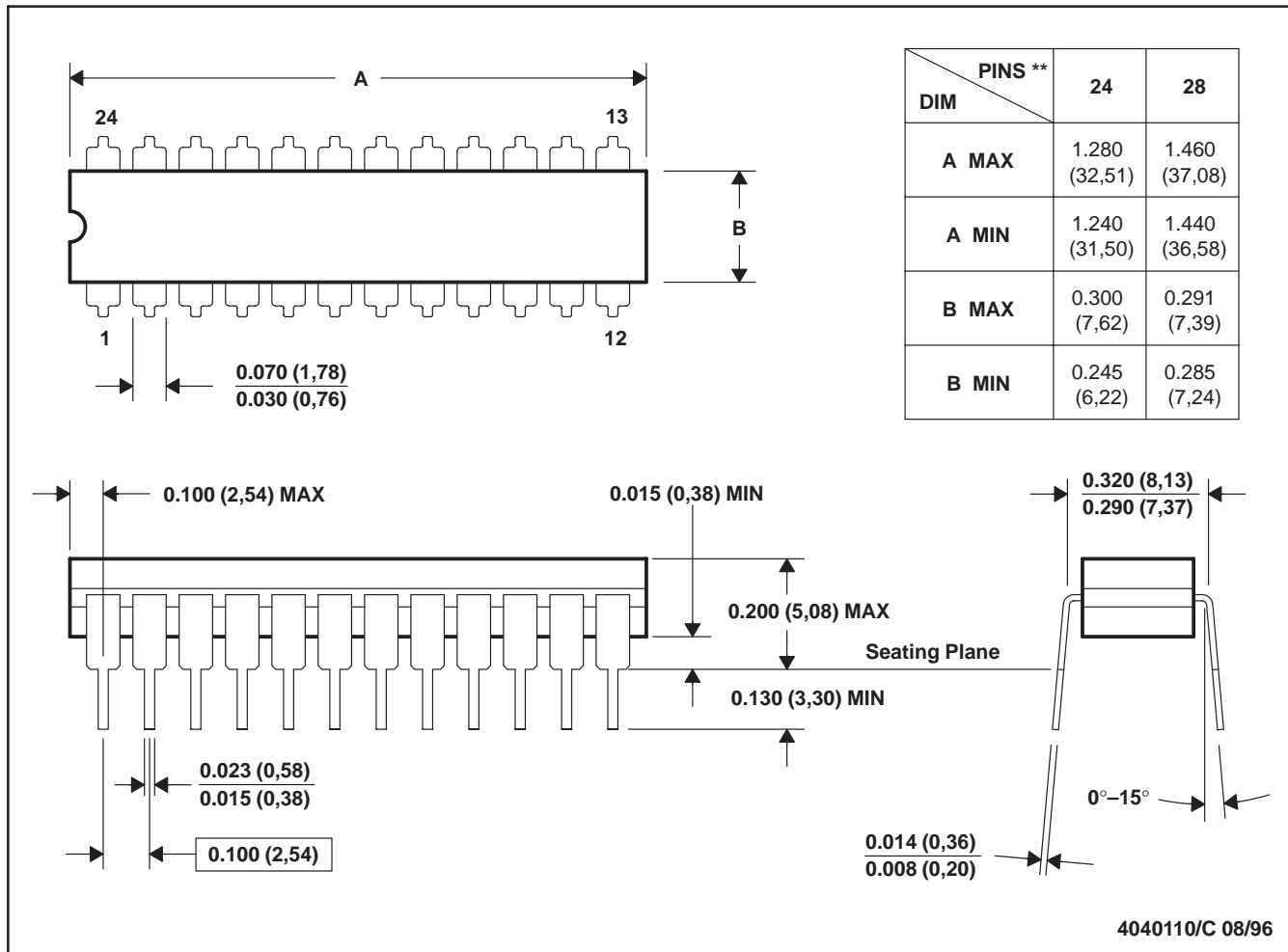

4040110/C 08/96

- NOTES: A. All linear dimensions are in inches (millimeters).
 B. This drawing is subject to change without notice.
 C. This package can be hermetically sealed with a ceramic lid using glass frit.
 D. Index point is provided on cap for terminal identification.
 E. Falls within MIL STD 1835 GDIP3-T24, GDIP4-T28, and JEDEC MO-058 AA, MO-058 AB

W (R-GDFP-F24)

CERAMIC DUAL FLATPACK

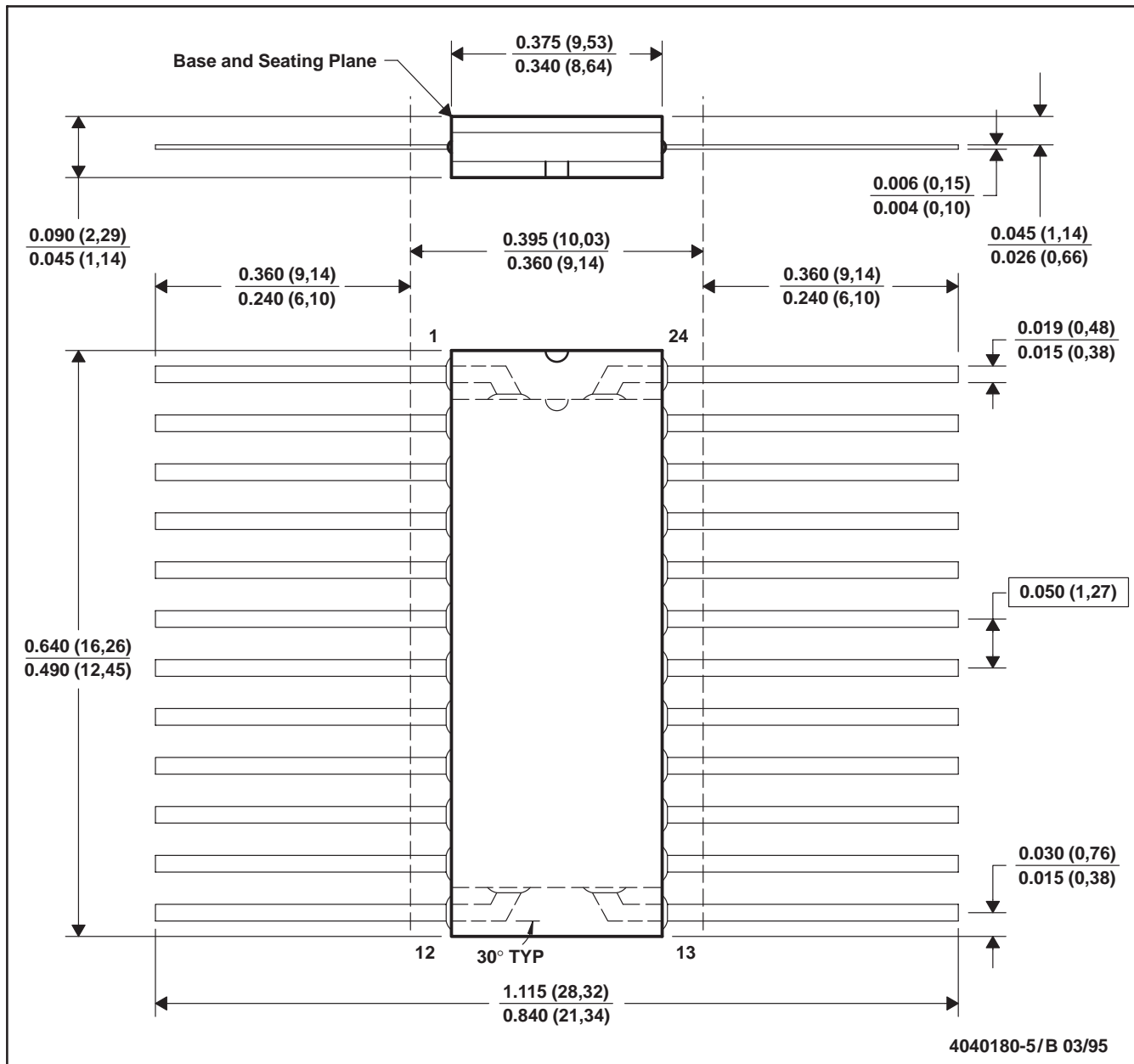

- NOTES:
- A. All linear dimensions are in inches (millimeters).
 - B. This drawing is subject to change without notice.
 - C. This package can be hermetically sealed with a ceramic lid using glass frit.
 - D. Falls within MIL-STD-1835 GDFP2-F24 and JEDEC MO-070AD
 - E. Index point is provided on cap for terminal identification only.

FK (S-CQCC-N**)

LEADLESS CERAMIC CHIP CARRIER

28 TERMINAL SHOWN



NO. OF TERMINALS **	A		B	
	MIN	MAX	MIN	MAX
20	0.342 (8,69)	0.358 (9,09)	0.307 (7,80)	0.358 (9,09)
28	0.442 (11,23)	0.458 (11,63)	0.406 (10,31)	0.458 (11,63)
44	0.640 (16,26)	0.660 (16,76)	0.495 (12,58)	0.560 (14,22)
52	0.740 (18,78)	0.761 (19,32)	0.495 (12,58)	0.560 (14,22)
68	0.938 (23,83)	0.962 (24,43)	0.850 (21,6)	0.858 (21,8)
84	1.141 (28,99)	1.165 (29,59)	1.047 (26,6)	1.063 (27,0)

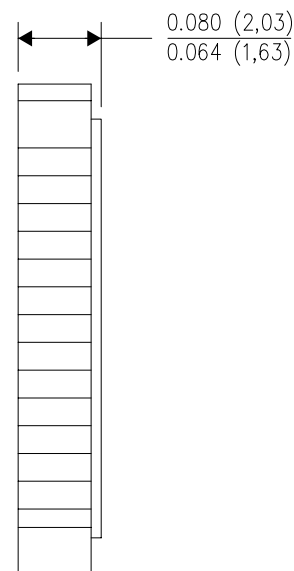
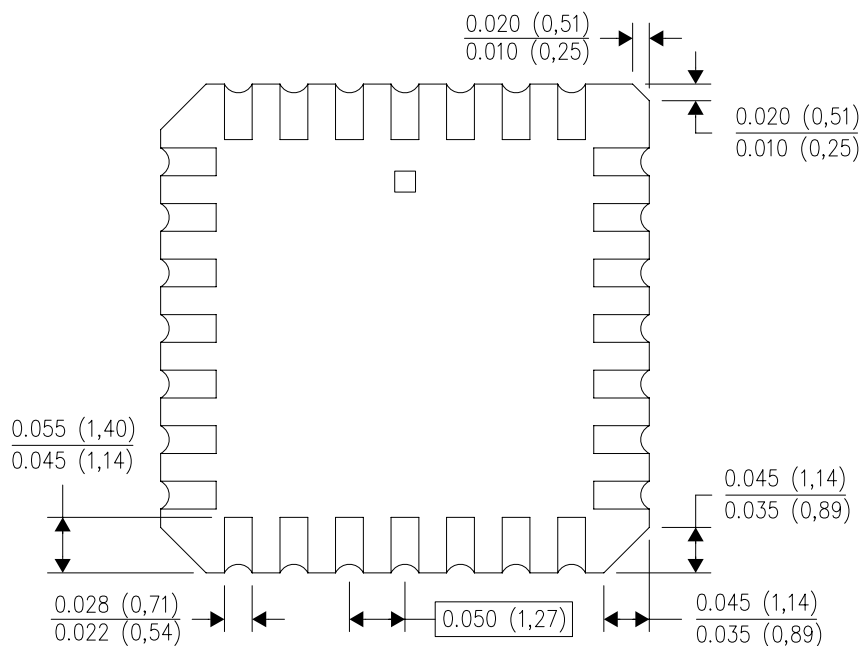

4040140/D 01/11

- NOTES:
- A. All linear dimensions are in inches (millimeters).
 - B. This drawing is subject to change without notice.
 - C. This package can be hermetically sealed with a metal lid.
 - D. Falls within JEDEC MS-004

MECHANICAL DATA

NT (R-PDIP-T**) 24 PINS SHOWN

PLASTIC DUAL-IN-LINE PACKAGE

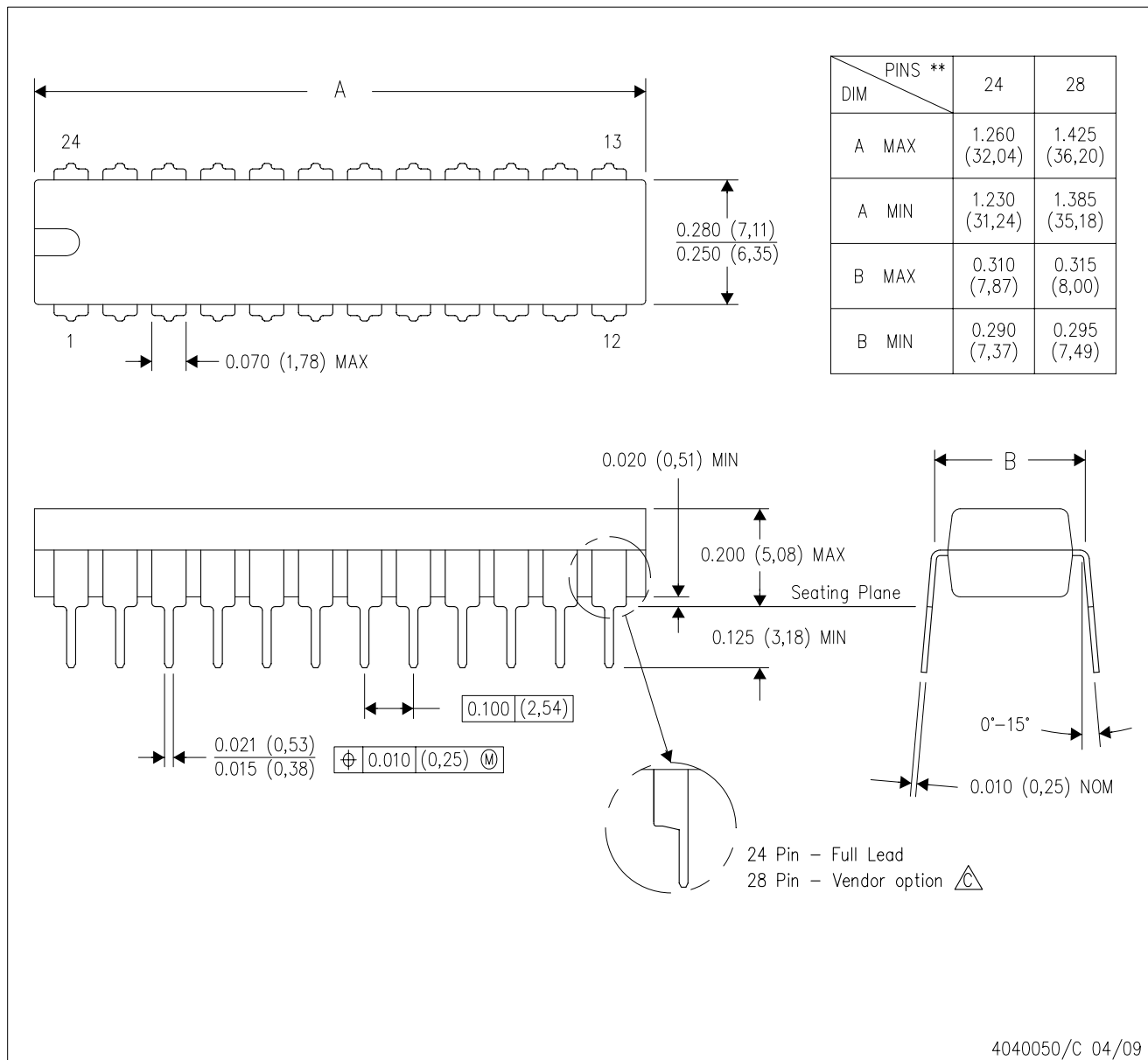

- NOTES:
- A. All linear dimensions are in millimeters. Dimensioning and tolerancing per ASME Y14.5M-1994.
 - B. This drawing is subject to change without notice.
 -  The 28 pin end lead shoulder width is a vendor option, either half or full width.

DW (R-PDSO-G24)

PLASTIC SMALL OUTLINE



- NOTES:
- A. All linear dimensions are in inches (millimeters). Dimensioning and tolerancing per ASME Y14.5M-1994.
 - B. This drawing is subject to change without notice.
 - C. Body dimensions do not include mold flash or protrusion not to exceed 0.006 (0,15).
 - D. Falls within JEDEC MS-013 variation AD.

IMPORTANT NOTICE

Texas Instruments Incorporated and its subsidiaries (TI) reserve the right to make corrections, modifications, enhancements, improvements, and other changes to its products and services at any time and to discontinue any product or service without notice. Customers should obtain the latest relevant information before placing orders and should verify that such information is current and complete. All products are sold subject to TI's terms and conditions of sale supplied at the time of order acknowledgment.

TI warrants performance of its hardware products to the specifications applicable at the time of sale in accordance with TI's standard warranty. Testing and other quality control techniques are used to the extent TI deems necessary to support this warranty. Except where mandated by government requirements, testing of all parameters of each product is not necessarily performed.

TI assumes no liability for applications assistance or customer product design. Customers are responsible for their products and applications using TI components. To minimize the risks associated with customer products and applications, customers should provide adequate design and operating safeguards.

TI does not warrant or represent that any license, either express or implied, is granted under any TI patent right, copyright, mask work right, or other TI intellectual property right relating to any combination, machine, or process in which TI products or services are used. Information published by TI regarding third-party products or services does not constitute a license from TI to use such products or services or a warranty or endorsement thereof. Use of such information may require a license from a third party under the patents or other intellectual property of the third party, or a license from TI under the patents or other intellectual property of TI.

Reproduction of TI information in TI data books or data sheets is permissible only if reproduction is without alteration and is accompanied by all associated warranties, conditions, limitations, and notices. Reproduction of this information with alteration is an unfair and deceptive business practice. TI is not responsible or liable for such altered documentation. Information of third parties may be subject to additional restrictions.

Resale of TI products or services with statements different from or beyond the parameters stated by TI for that product or service voids all express and any implied warranties for the associated TI product or service and is an unfair and deceptive business practice. TI is not responsible or liable for any such statements.

TI products are not authorized for use in safety-critical applications (such as life support) where a failure of the TI product would reasonably be expected to cause severe personal injury or death, unless officers of the parties have executed an agreement specifically governing such use. Buyers represent that they have all necessary expertise in the safety and regulatory ramifications of their applications, and acknowledge and agree that they are solely responsible for all legal, regulatory and safety-related requirements concerning their products and any use of TI products in such safety-critical applications, notwithstanding any applications-related information or support that may be provided by TI. Further, Buyers must fully indemnify TI and its representatives against any damages arising out of the use of TI products in such safety-critical applications.

TI products are neither designed nor intended for use in military/aerospace applications or environments unless the TI products are specifically designated by TI as military-grade or "enhanced plastic." Only products designated by TI as military-grade meet military specifications. Buyers acknowledge and agree that any such use of TI products which TI has not designated as military-grade is solely at the Buyer's risk, and that they are solely responsible for compliance with all legal and regulatory requirements in connection with such use.

TI products are neither designed nor intended for use in automotive applications or environments unless the specific TI products are designated by TI as compliant with ISO/TS 16949 requirements. Buyers acknowledge and agree that, if they use any non-designated products in automotive applications, TI will not be responsible for any failure to meet such requirements.

Following are URLs where you can obtain information on other Texas Instruments products and application solutions:

Products

Audio	www.ti.com/audio
Amplifiers	amplifier.ti.com
Data Converters	dataconverter.ti.com
DLP® Products	www.dlp.com
DSP	dsp.ti.com
Clocks and Timers	www.ti.com/clocks
Interface	interface.ti.com
Logic	logic.ti.com
Power Mgmt	power.ti.com
Microcontrollers	microcontroller.ti.com
RFID	www.ti-rfid.com
OMAP Mobile Processors	www.ti.com/omap
Wireless Connectivity	www.ti.com/wirelessconnectivity

Applications

Communications and Telecom	www.ti.com/communications
Computers and Peripherals	www.ti.com/computers
Consumer Electronics	www.ti.com/consumer-apps
Energy and Lighting	www.ti.com/energy
Industrial	www.ti.com/industrial
Medical	www.ti.com/medical
Security	www.ti.com/security
Space, Avionics and Defense	www.ti.com/space-avionics-defense
Transportation and Automotive	www.ti.com/automotive
Video and Imaging	www.ti.com/video

TI E2E Community Home Page

e2e.ti.com

Mailing Address: Texas Instruments, Post Office Box 655303, Dallas, Texas 75265
Copyright © 2011, Texas Instruments Incorporated