

# SN54ALS169B, SN54AS169A, SN74ALS169B, SN74AS169A SYNCHRONOUS 4-BIT UP/DOWN BINARY COUNTERS

SDAS125B – MARCH 1984 – REVISED DECEMBER 1994

- Fully Synchronous Operation for Counting and Programming
- Internal Carry Look-Ahead Circuitry for Fast Counting
- Carry Output for n-Bit Cascading
- Fully Independent Clock Circuit
- Package Options Include Plastic Small-Outline (D) Packages, Ceramic Chip Carriers (FK), and Standard Plastic (N) and Ceramic (J) 300-mil DIPs

## description

These synchronous 4-bit up/down binary presetable counters feature an internal carry look-ahead circuitry for cascading in high-speed counting applications. Synchronous operation is provided by having all flip-flops clocked simultaneously so that the outputs change coincident with each other when so instructed by the count-enable ( $\overline{\text{ENP}}$ ,  $\overline{\text{ENT}}$ ) inputs and internal gating. This mode of operation eliminates the output counting spikes normally associated with asynchronous (ripple-clock) counters. A buffered clock (CLK) input triggers the four flip-flops on the rising (positive-going) edge of the clock waveform.

These counters are fully programmable; that is, they may be preset to either level. The load-input circuitry allows loading with the carry-enable output of cascaded counters. Because loading is synchronous, setting up a low level at the load ( $\overline{\text{LOAD}}$ ) input disables the counter and causes the outputs to agree with the data inputs after the next clock pulse.

The internal carry look-ahead circuitry provides for cascading counters for n-bit synchronous application without additional gating.  $\overline{\text{ENP}}$  and  $\overline{\text{ENT}}$  inputs and a ripple-carry output ( $\overline{\text{RCO}}$ ) are instrumental in accomplishing this function. Both  $\overline{\text{ENP}}$  and  $\overline{\text{ENT}}$  must be low to count. The direction of the count is determined by the level of the up/down ( $\overline{\text{U/D}}$ ) input. When  $\overline{\text{U/D}}$  is high, the counter counts up; when low, it counts down.  $\overline{\text{ENT}}$  is fed forward to enable  $\overline{\text{RCO}}$ .  $\overline{\text{RCO}}$ , thus enabled, produces a low-level pulse while the count is zero (all inputs low) counting down or maximum (15) counting up. This low-level overflow ripple-carry pulse can be used to enable successive cascaded stages. Transitions at  $\overline{\text{ENP}}$  or  $\overline{\text{ENT}}$  are allowed regardless of the level of the clock input. All inputs are diode clamped to minimize transmission-line effects, thereby simplifying system design.

These counters feature a fully independent clock circuit. Changes at control inputs ( $\overline{\text{ENP}}$ ,  $\overline{\text{ENT}}$ ,  $\overline{\text{LOAD}}$ , or  $\overline{\text{U/D}}$ ) that modify the operating mode have no effect on the contents of the counter until clocking occurs. The function of the counter (whether enabled, disabled, loading, or counting) is dictated solely by the conditions meeting the stable setup and hold times.

The SN54ALS169B and SN54AS169A are characterized for operation over the full military temperature range of  $-55^{\circ}\text{C}$  to  $125^{\circ}\text{C}$ . The SN74ALS169B and SN74AS169A are characterized for operation from  $0^{\circ}\text{C}$  to  $70^{\circ}\text{C}$ .

SN54ALS169B, SN54AS169A . . . J PACKAGE  
SN74ALS169B, SN74AS169A . . . D OR N PACKAGE  
(TOP VIEW)

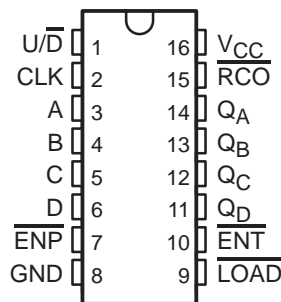

SN54ALS169B, SN54AS169A . . . FK PACKAGE  
(TOP VIEW)

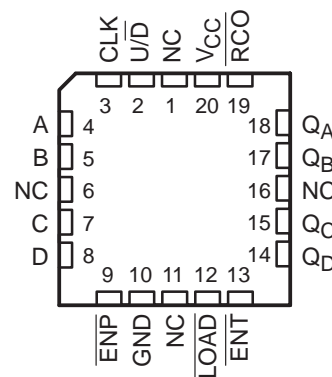

NC – No internal connection

# SN54ALS169B, SN54AS169A, SN74ALS169B, SN74AS169A SYNCHRONOUS 4-BIT UP/DOWN BINARY COUNTERS

SDAS125B – MARCH 1984 – REVISED DECEMBER 1994

## logic symbol†

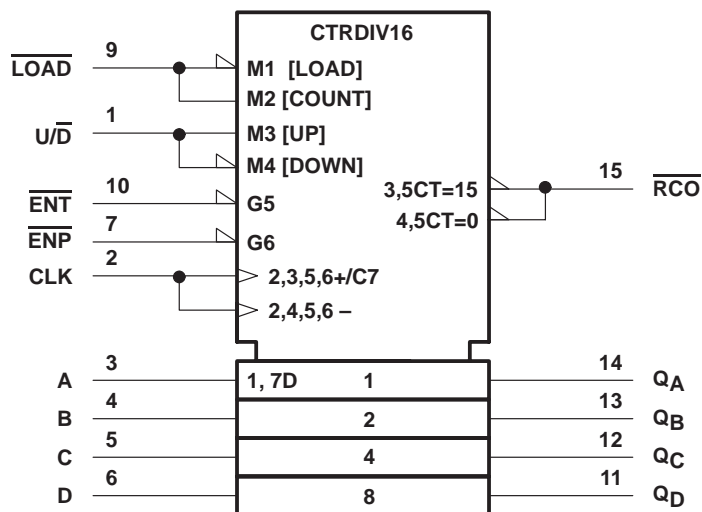

† This symbol is in accordance with ANSI/IEEE Std 91-1984 and IEC Publication 617-12.  
Pin numbers shown are for the D, J, and N packages.

# SN54ALS169B, SN54AS169A, SN74ALS169B, SN74AS169A SYNCHRONOUS 4-BIT UP/DOWN BINARY COUNTERS

SDAS125B – MARCH 1984 – REVISED DECEMBER 1994

## logic diagram (positive logic)

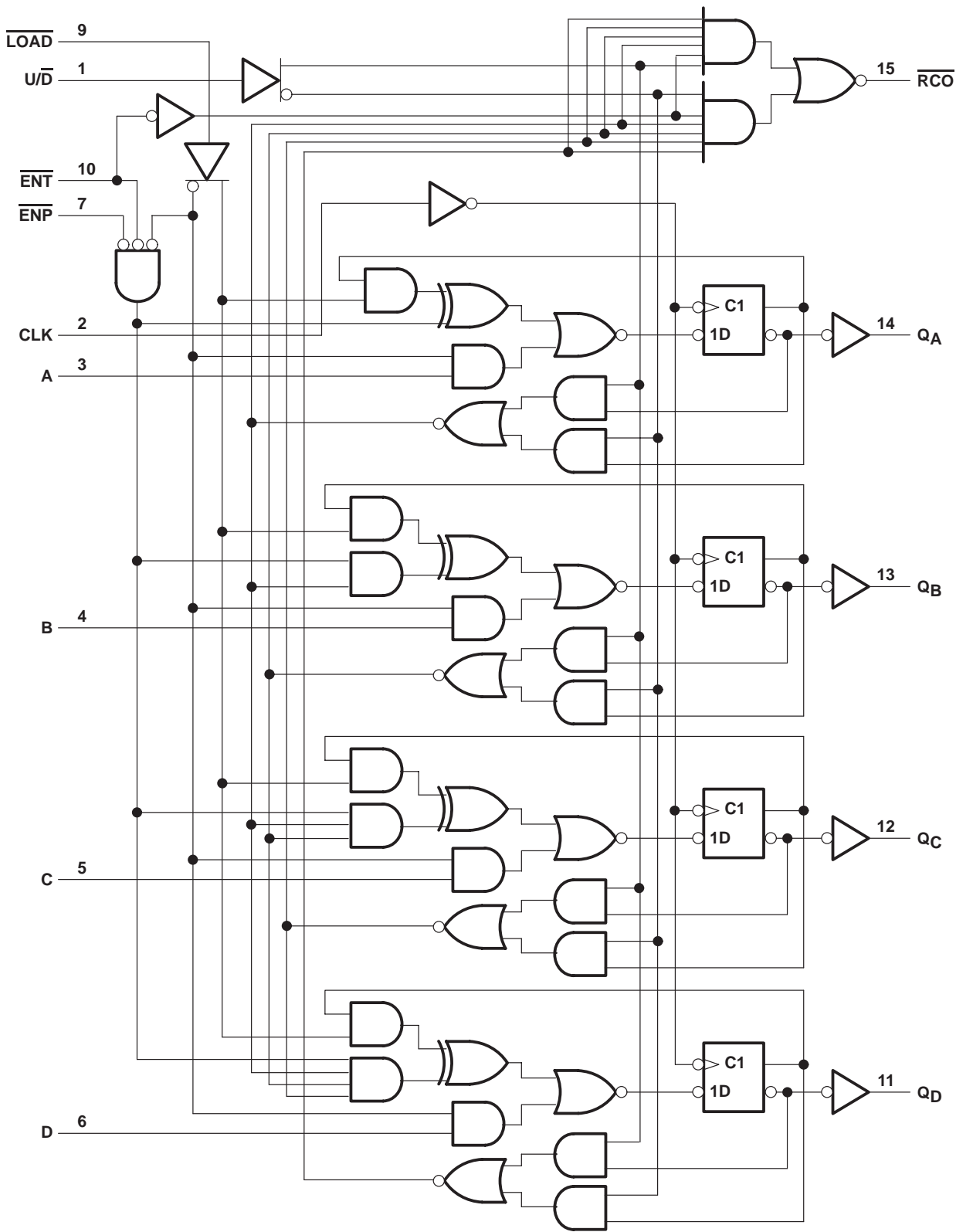

Pin numbers shown are for the D, J, and N packages.



# SN54ALS169B, SN54AS169A, SN74ALS169B, SN74AS169A SYNCHRONOUS 4-BIT UP/DOWN BINARY COUNTERS

SDAS125B – MARCH 1984 – REVISED DECEMBER 1994

## typical load, count, and inhibit sequences

The following sequence is illustrated below:

1. Load (preset) to binary 13
2. Count up to 14, 15 (maximum), 0, 1, and 2
3. Inhibit
4. Count down to 1, 0 (minimum), 15, 14, and 13

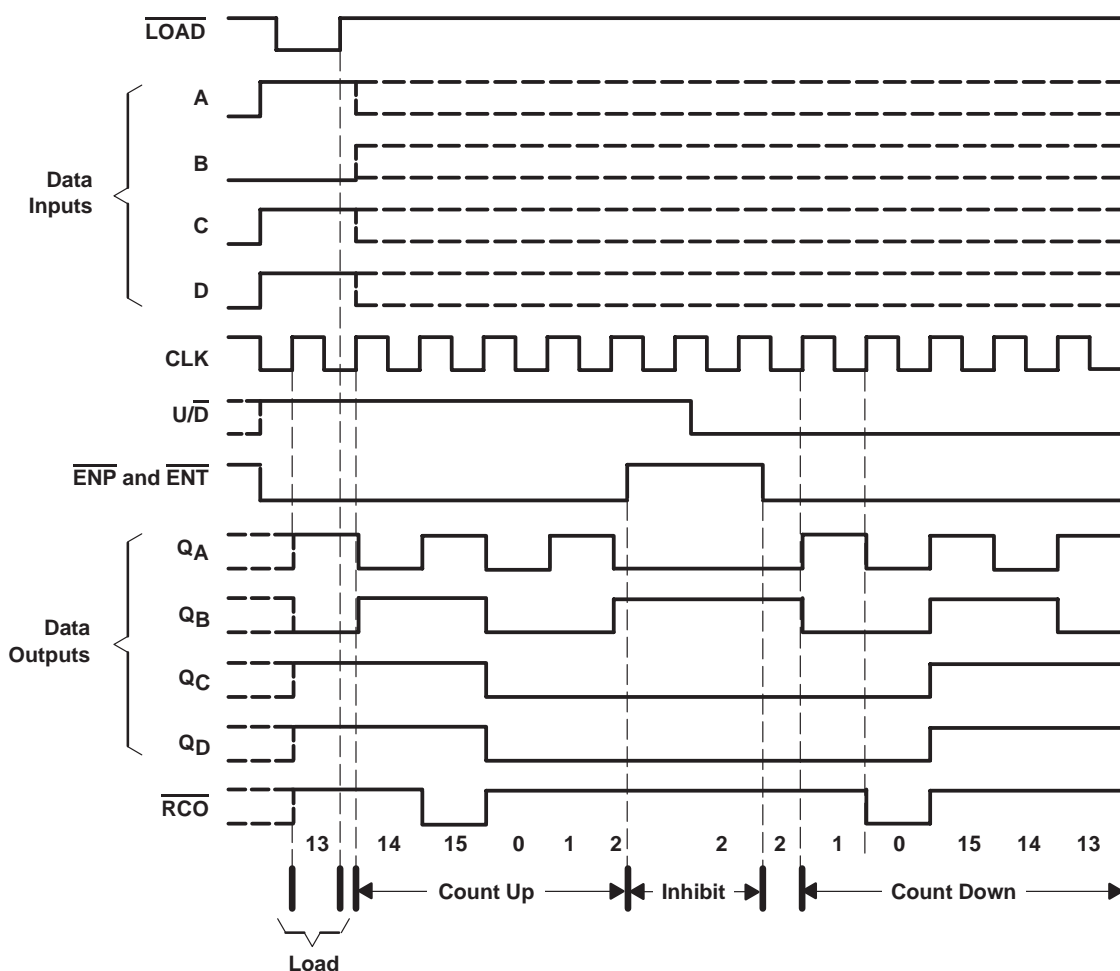

## absolute maximum ratings over operating free-air temperature range (unless otherwise noted)†

Supply voltage, $V_{CC}$	7 V
Input voltage, $V_I$	7 V
Operating free-air temperature range, $T_A$ : SN54ALS169B	-55°C to 125°C
SN74ALS169B	0°C to 70°C
Storage temperature range	-65°C to 150°C

† Stresses beyond those listed under "absolute maximum ratings" may cause permanent damage to the device. These are stress ratings only, and functional operation of the device at these or any other conditions beyond those indicated under "recommended operating conditions" is not implied. Exposure to absolute-maximum-rated conditions for extended periods may affect device reliability.

# SN54ALS169B, SN54AS169A, SN74ALS169B, SN74AS169A SYNCHRONOUS 4-BIT UP/DOWN BINARY COUNTERS

SDAS125B – MARCH 1984 – REVISED DECEMBER 1994

## recommended operating conditions

		SN54ALS169B			SN74ALS169B			UNIT
		MIN	NOM	MAX	MIN	NOM	MAX	
$V_{CC}$	Supply voltage	4.5	5	5.5	4.5	5	5.5	V
$V_{IH}$	High-level input voltage	2			2			V
$V_{IL}$	Low-level input voltage			0.7			0.8	V
$I_{OH}$	High-level output current			-0.4			-0.4	mA
$I_{OL}$	Low-level output current			4			8	mA
$f_{clock}$	Clock frequency	0		22	0		40	MHz
$t_w$	Pulse duration, CLK high or low	14			12.5			ns
$t_{su}$	Setup time before CLK $\uparrow$	A, B, C, or D		20		15		ns
		$\overline{ENP}$ or $\overline{ENT}$		25		15		
		$\overline{LOAD}$		20		15		
		$\overline{U/D}$		28		15		
$t_h$	Hold time, data after CLK $\uparrow$	0			0			ns
$T_A$	Operating free-air temperature	-55		125	0		70	°C

## electrical characteristics over recommended operating free-air temperature range (unless otherwise noted)

PARAMETER	TEST CONDITIONS	SN54ALS169B			SN74ALS169B			UNIT
		MIN	TYP $\dagger$	MAX	MIN	TYP $\dagger$	MAX	
$V_{IK}$	$V_{CC} = 4.5\text{ V}$ , $I_I = -18\text{ mA}$			-1.5			-1.5	V
$V_{OH}$	$V_{CC} = 4.5\text{ V to } 5.5\text{ V}$ , $I_{OH} = -0.4\text{ mA}$	$V_{CC} - 2$			$V_{CC} - 2$			V
$V_{OL}$	$V_{CC} = 4.5\text{ V}$	$I_{OL} = 4\text{ mA}$	0.25	0.4	0.25	0.4	V	
		$I_{OL} = 8\text{ mA}$			0.35	0.5		
$I_I$	$V_{CC} = 5.5\text{ V}$ , $V_I = 7\text{ V}$			0.1		0.1	mA	
$I_{IH}$	$V_{CC} = 5.5\text{ V}$ , $V_I = 2.7\text{ V}$			20		20	$\mu\text{A}$	
$I_{IL}$	$V_{CC} = 5.5\text{ V}$ , $V_I = 0.4\text{ V}$			-0.2		-0.2	mA	
$I_{O\ddagger}$	$V_{CC} = 5.5\text{ V}$ , $V_O = 2.25\text{ V}$	-20		-112	-30		-112	mA
$I_{CC}$	$V_{CC} = 5.5\text{ V}$		15	25		15	25	mA

$\dagger$  All typical values are at  $V_{CC} = 5\text{ V}$ ,  $T_A = 25^\circ\text{C}$ .

$\ddagger$  The output conditions have been chosen to produce a current that closely approximates one half of the true short-circuit output current,  $I_{OS}$ .



# SN54ALS169B, SN54AS169A, SN74ALS169B, SN74AS169A SYNCHRONOUS 4-BIT UP/DOWN BINARY COUNTERS

SDAS125B – MARCH 1984 – REVISED DECEMBER 1994

## switching characteristics (see Figure 1)

PARAMETER	FROM (INPUT)	TO (OUTPUT)	V <sub>CC</sub> = 4.5 V to 5.5 V, C <sub>L</sub> = 50 pF, R <sub>L</sub> = 500 Ω, T <sub>A</sub> = MIN to MAX†				UNIT
			SN54ALS169B		SN74ALS169B		
			MIN	MAX	MIN	MAX	
f <sub>max</sub>			22		40		MHz
t <sub>PLH</sub>	CLK	$\overline{RCO}$	3	20	3	20	ns
t <sub>PHL</sub>			6	25	6	20	
t <sub>PLH</sub>	CLK	Any Q	2	20	2	15	ns
t <sub>PHL</sub>			5	23	5	20	
t <sub>PLH</sub>	$\overline{ENT}$	$\overline{RCO}$	2	16	2	13	ns
t <sub>PHL</sub>			3	24	3	16	
t <sub>PLH</sub>	U/ $\overline{D}$	$\overline{RCO}$	4	22	5	19	ns
t <sub>PHL</sub>			5	26	5	19	

† For conditions shown as MIN or MAX, use the appropriate value specified under recommended operating conditions.

## absolute maximum ratings over operating free-air temperature range (unless otherwise noted)‡

Supply voltage, V <sub>CC</sub>	7 V
Input voltage, V <sub>I</sub>	7 V
Operating free-air temperature range, T <sub>A</sub> : SN54AS169A	–55°C to 125°C
SN74AS169A	0°C to 70°C
Storage temperature range	–65°C to 150°C

‡ Stresses beyond those listed under “absolute maximum ratings” may cause permanent damage to the device. These are stress ratings only, and functional operation of the device at these or any other conditions beyond those indicated under “recommended operating conditions” is not implied. Exposure to absolute-maximum-rated conditions for extended periods may affect device reliability.

## recommended operating conditions

		SN54AS169A			SN74AS169A			UNIT
		MIN	NOM	MAX	MIN	NOM	MAX	
V <sub>CC</sub>	Supply voltage	4.5	5	5.5	4.5	5	5.5	V
V <sub>IH</sub>	High-level input voltage	2			2			V
V <sub>IL</sub>	Low-level input voltage			0.8			0.8	V
I <sub>OH</sub>	High-level output current			–2			–2	mA
I <sub>OL</sub>	Low-level output current			20			20	mA
f <sub>clock</sub> *	Clock frequency	0		60	0		75	MHz
t <sub>w</sub> *	Pulse duration, CLK high or low	7.7			6.7			ns
t <sub>su</sub> *	Setup time before CLK↑	A, B, C, or D		10		8		ns
		$\overline{ENP}$ or $\overline{ENT}$		10		8		
		$\overline{LOAD}$		10		8		
		U/ $\overline{D}$		14		11		
t <sub>h</sub> *	Hold time, data after CLK↑	2			0			ns
T <sub>A</sub>	Operating free-air temperature	–55		125	0		70	°C

\* On products compliant to MIL-STD-883, Class B, this parameter is based on characterization data but is not production tested.



# SN54ALS169B, SN54AS169A, SN74ALS169B, SN74AS169A SYNCHRONOUS 4-BIT UP/DOWN BINARY COUNTERS

SDAS125B – MARCH 1984 – REVISED DECEMBER 1994

**electrical characteristics over recommended operating free-air temperature range (unless otherwise noted)**

PARAMETER	TEST CONDITIONS	SN54AS169A		SN74AS169A		UNIT	
		MIN	TYP†	MAX	MIN		TYP†
$V_{IK}$	$V_{CC} = 4.5\text{ V}$ , $I_I = -18\text{ mA}$			-1.2		-1.2	V
$V_{OH}$	$V_{CC} = 4.5\text{ V to } 5.5\text{ V}$ , $I_{OH} = -2\text{ mA}$	$V_{CC} - 2$			$V_{CC} - 2$		V
$V_{OL}$	$V_{CC} = 4.5\text{ V}$ , $I_{OL} = 20\text{ mA}$		0.25	0.5		0.25 0.5	V
$I_I$	$\overline{\text{LOAD}}, \overline{\text{ENT}}, \text{U}/\overline{\text{D}}$			0.2		0.2	mA
	All others			0.1		0.1	
$I_{IH}$	$\overline{\text{LOAD}}, \overline{\text{ENT}}, \text{U}/\overline{\text{D}}$			40		40	$\mu\text{A}$
	All others			20		20	
$I_{IL}$	$\overline{\text{LOAD}}, \overline{\text{ENT}}, \text{U}/\overline{\text{D}}$			-1		-1	mA
	All others			-0.5		-0.5	
$I_{O\ddagger}$	$V_{CC} = 5.5\text{ V}$ , $V_O = 2.25\text{ V}$	-30		-112	-30	-112	mA
$I_{CC}$	$V_{CC} = 5.5\text{ V}$		41	63		41 63	mA

† All typical values are at  $V_{CC} = 5\text{ V}$ ,  $T_A = 25^\circ\text{C}$ .

‡ The output conditions have been chosen to produce a current that closely approximates one half of the true short-circuit output current,  $I_{OS}$ .

## switching characteristics (see Figure 1)

PARAMETER	FROM (INPUT)	TO (OUTPUT)	$V_{CC} = 4.5\text{ V to } 5.5\text{ V}$ , $C_L = 50\text{ pF}$ , $R_L = 500\ \Omega$ , $T_A = \text{MIN to MAX}\S$				UNIT
			SN54AS169A		SN74AS169A		
			MIN	MAX	MIN	MAX	
$f_{max}^*$			60		75	MHz	
$t_{PLH}$	CLK	$\overline{\text{RCO}}$ ( $\overline{\text{LOAD}}$ high or low)	3	17.5	3	16.5	ns
$t_{PHL}$			2	14	2	13	
$t_{PLH}$	CLK	Any Q	1	7.5	1	7	ns
$t_{PHL}$			2	14	2	13	
$t_{PLH}$	$\overline{\text{ENT}}$	$\overline{\text{RCO}}$	1.5	10	1.5	9	ns
$t_{PHL}$			1.5	10	1.5	9	
$t_{PLH}$	$\text{U}/\overline{\text{D}}$	$\overline{\text{RCO}}$	2	14	2	12	ns
$t_{PHL}$			2	14.5	2	13	

\* On products compliant to MIL-STD-883, Class B, this parameter is based on characterization data but is not production tested.

§ For conditions shown as MIN or MAX, use the appropriate value specified under recommended operating conditions.

# SN54ALS169B, SN54AS169A, SN74ALS169B, SN74AS169A SYNCHRONOUS 4-BIT UP/DOWN BINARY COUNTERS

SDAS125B – MARCH 1984 – REVISED DECEMBER 1994

## PARAMETER MEASUREMENT INFORMATION SERIES 54ALS/74ALS AND 54AS/74AS DEVICES

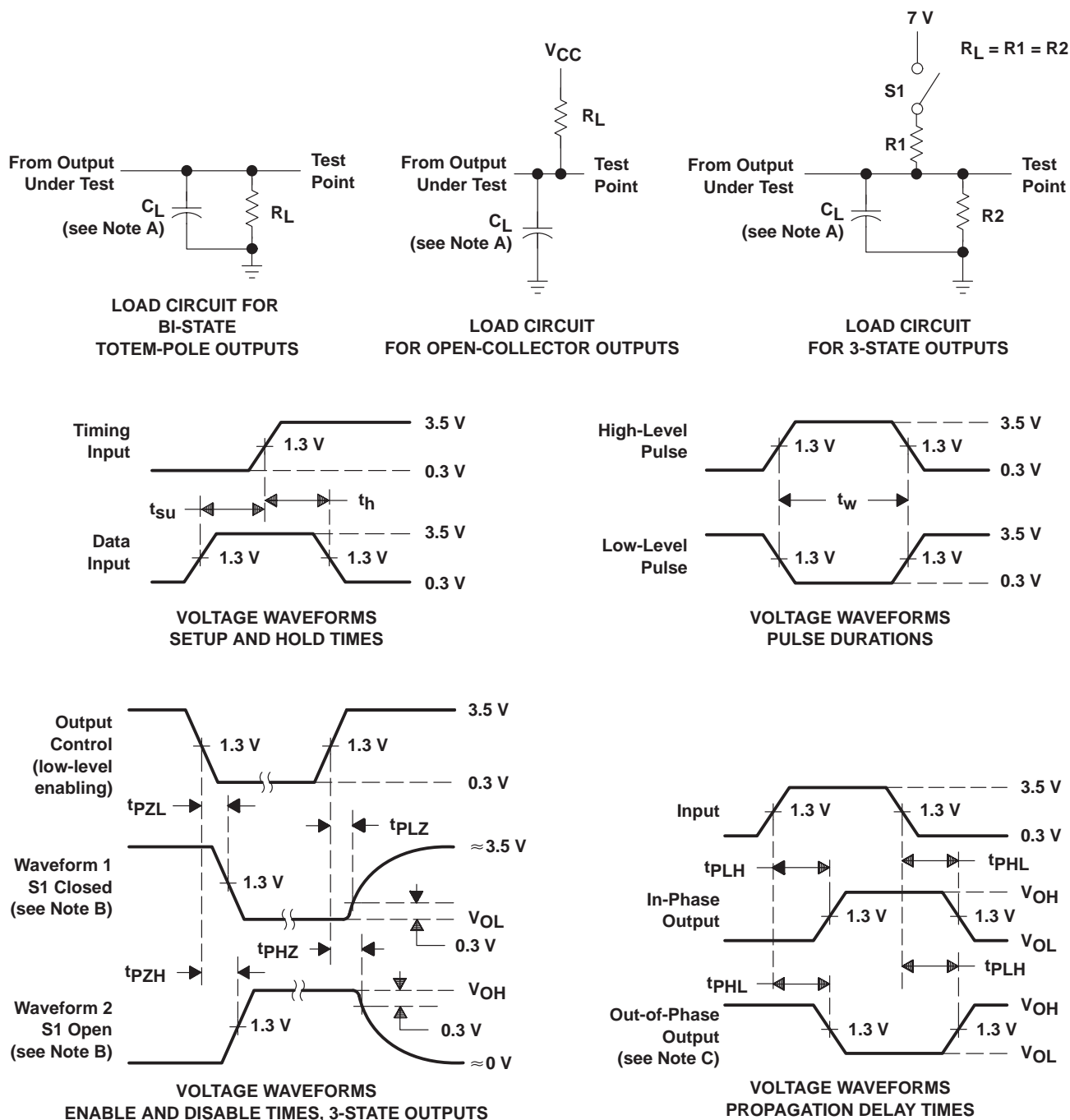

- NOTES: A.  $C_L$  includes probe and jig capacitance.  
 B. Waveform 1 is for an output with internal conditions such that the output is low except when disabled by the output control. Waveform 2 is for an output with internal conditions such that the output is high except when disabled by the output control.  
 C. When measuring propagation delay items of 3-state outputs, switch S1 is open.  
 D. All input pulses have the following characteristics:  $PRR \leq 1$  MHz,  $t_r = t_f = 2$  ns, duty cycle = 50%.  
 E. The outputs are measured one at a time with one transition per measurement.

Figure 1. Load Circuits and Voltage Waveforms

**PACKAGING INFORMATION**

Orderable Device	Status <sup>(1)</sup>	Package Type	Package Drawing	Pins	Package Qty	Eco Plan <sup>(2)</sup>	Lead/Ball Finish	MSL Peak Temp <sup>(3)</sup>
83025012A	ACTIVE	LCCC	FK	20	1	TBD	POST-PLATE	N / A for Pkg Type
8302501EA	ACTIVE	CDIP	J	16	1	TBD	A42 SNPB	N / A for Pkg Type
8302501FA	OBSOLETE	CFP	W	16		TBD	Call TI	Call TI
JM38510/38003B2A	ACTIVE	LCCC	FK	20	1	TBD	POST-PLATE	N / A for Pkg Type
JM38510/38003BEA	ACTIVE	CDIP	J	16	1	TBD	A42 SNPB	N / A for Pkg Type
SN54ALS169BJ	ACTIVE	CDIP	J	16	1	TBD	A42 SNPB	N / A for Pkg Type
SN54AS169AJ	OBSOLETE	CDIP	J	16		TBD	Call TI	Call TI
SN74ALS169BD	ACTIVE	SOIC	D	16	40	Green (RoHS & no Sb/Br)	CU NIPDAU	Level-1-260C-UNLIM
SN74ALS169BDE4	ACTIVE	SOIC	D	16	40	Green (RoHS & no Sb/Br)	CU NIPDAU	Level-1-260C-UNLIM
SN74ALS169BDR	ACTIVE	SOIC	D	16	2500	Green (RoHS & no Sb/Br)	CU NIPDAU	Level-1-260C-UNLIM
SN74ALS169BDRE4	ACTIVE	SOIC	D	16	2500	Green (RoHS & no Sb/Br)	CU NIPDAU	Level-1-260C-UNLIM
SN74ALS169BN	ACTIVE	PDIP	N	16	25	Pb-Free (RoHS)	CU NIPDAU	N / A for Pkg Type
SN74ALS169BNE4	ACTIVE	PDIP	N	16	25	Pb-Free (RoHS)	CU NIPDAU	N / A for Pkg Type
SN74ALS169BNSR	ACTIVE	SO	NS	16	2000	Green (RoHS & no Sb/Br)	CU NIPDAU	Level-1-260C-UNLIM
SN74ALS169BNSRE4	ACTIVE	SO	NS	16	2000	Green (RoHS & no Sb/Br)	CU NIPDAU	Level-1-260C-UNLIM
SN74AS169AD	ACTIVE	SOIC	D	16	40	Green (RoHS & no Sb/Br)	CU NIPDAU	Level-1-260C-UNLIM
SN74AS169ADE4	ACTIVE	SOIC	D	16	40	Green (RoHS & no Sb/Br)	CU NIPDAU	Level-1-260C-UNLIM
SN74AS169ADR	ACTIVE	SOIC	D	16	2500	Green (RoHS & no Sb/Br)	CU NIPDAU	Level-1-260C-UNLIM
SN74AS169ADRE4	ACTIVE	SOIC	D	16	2500	Green (RoHS & no Sb/Br)	CU NIPDAU	Level-1-260C-UNLIM
SN74AS169AN	ACTIVE	PDIP	N	16	25	Pb-Free (RoHS)	CU NIPDAU	N / A for Pkg Type
SN74AS169ANE4	ACTIVE	PDIP	N	16	25	Pb-Free (RoHS)	CU NIPDAU	N / A for Pkg Type
SNJ54ALS169BFBK	ACTIVE	LCCC	FK	20	1	TBD	POST-PLATE	N / A for Pkg Type
SNJ54ALS169BJ	ACTIVE	CDIP	J	16	1	TBD	A42 SNPB	N / A for Pkg Type
SNJ54AS169AFK	OBSOLETE	LCCC	FK	20		TBD	Call TI	Call TI
SNJ54AS169AJ	OBSOLETE	CDIP	J	16		TBD	Call TI	Call TI

<sup>(1)</sup> The marketing status values are defined as follows:

**ACTIVE:** Product device recommended for new designs.

**LIFEBUY:** TI has announced that the device will be discontinued, and a lifetime-buy period is in effect.

**NRND:** Not recommended for new designs. Device is in production to support existing customers, but TI does not recommend using this part in a new design.

**PREVIEW:** Device has been announced but is not in production. Samples may or may not be available.

**OBSOLETE:** TI has discontinued the production of the device.

<sup>(2)</sup> Eco Plan - The planned eco-friendly classification: Pb-Free (RoHS), Pb-Free (RoHS Exempt), or Green (RoHS & no Sb/Br) - please check

<http://www.ti.com/productcontent> for the latest availability information and additional product content details.

**TBD:** The Pb-Free/Green conversion plan has not been defined.

**Pb-Free (RoHS):** TI's terms "Lead-Free" or "Pb-Free" mean semiconductor products that are compatible with the current RoHS requirements for all 6 substances, including the requirement that lead not exceed 0.1% by weight in homogeneous materials. Where designed to be soldered at high temperatures, TI Pb-Free products are suitable for use in specified lead-free processes.

**Pb-Free (RoHS Exempt):** This component has a RoHS exemption for either 1) lead-based flip-chip solder bumps used between the die and package, or 2) lead-based die adhesive used between the die and leadframe. The component is otherwise considered Pb-Free (RoHS compatible) as defined above.

**Green (RoHS & no Sb/Br):** TI defines "Green" to mean Pb-Free (RoHS compatible), and free of Bromine (Br) and Antimony (Sb) based flame retardants (Br or Sb do not exceed 0.1% by weight in homogeneous material)

<sup>(3)</sup> MSL, Peak Temp. -- The Moisture Sensitivity Level rating according to the JEDEC industry standard classifications, and peak solder temperature.

**Important Information and Disclaimer:**The information provided on this page represents TI's knowledge and belief as of the date that it is provided. TI bases its knowledge and belief on information provided by third parties, and makes no representation or warranty as to the accuracy of such information. Efforts are underway to better integrate information from third parties. TI has taken and continues to take reasonable steps to provide representative and accurate information but may not have conducted destructive testing or chemical analysis on incoming materials and chemicals. TI and TI suppliers consider certain information to be proprietary, and thus CAS numbers and other limited information may not be available for release.

In no event shall TI's liability arising out of such information exceed the total purchase price of the TI part(s) at issue in this document sold by TI to Customer on an annual basis.

J (R-GDIP-T\*\*)

14 LEADS SHOWN

CERAMIC DUAL IN-LINE PACKAGE



DIM \ PINS **	14	16	18	20
A	0.300 (7,62) BSC	0.300 (7,62) BSC	0.300 (7,62) BSC	0.300 (7,62) BSC
B MAX	0.785 (19,94)	.840 (21,34)	0.960 (24,38)	1.060 (26,92)
B MIN	—	—	—	—
C MAX	0.300 (7,62)	0.300 (7,62)	0.310 (7,87)	0.300 (7,62)
C MIN	0.245 (6,22)	0.245 (6,22)	0.220 (5,59)	0.245 (6,22)



4040083/F 03/03

- NOTES:
- All linear dimensions are in inches (millimeters).
  - This drawing is subject to change without notice.
  - This package is hermetically sealed with a ceramic lid using glass frit.
  - Index point is provided on cap for terminal identification only on press ceramic glass frit seal only.
  - Falls within MIL STD 1835 GDIP1-T14, GDIP1-T16, GDIP1-T18 and GDIP1-T20.

W (R-GDFP-F16)

CERAMIC DUAL FLATPACK



- NOTES:
- A. All linear dimensions are in inches (millimeters).
  - B. This drawing is subject to change without notice.
  - C. This package can be hermetically sealed with a ceramic lid using glass frit.
  - D. Index point is provided on cap for terminal identification only.
  - E. Falls within MIL STD 1835 GDFP1-F16 and JEDEC MO-092AC

FK (S-CQCC-N\*\*)

LEADLESS CERAMIC CHIP CARRIER

28 TERMINAL SHOWN



4040140/D 10/96

- NOTES:
- A. All linear dimensions are in inches (millimeters).
  - B. This drawing is subject to change without notice.
  - C. This package can be hermetically sealed with a metal lid.
  - D. The terminals are gold plated.
  - E. Falls within JEDEC MS-004

N (R-PDIP-T\*\*)

PLASTIC DUAL-IN-LINE PACKAGE

16 PINS SHOWN



- NOTES:
- A. All linear dimensions are in inches (millimeters).
  - B. This drawing is subject to change without notice.
  - Falls within JEDEC MS-001, except 18 and 20 pin minimum body length (Dim A).
  - The 20 pin end lead shoulder width is a vendor option, either half or full width.

D (R-PDSO-G16)

PLASTIC SMALL-OUTLINE PACKAGE

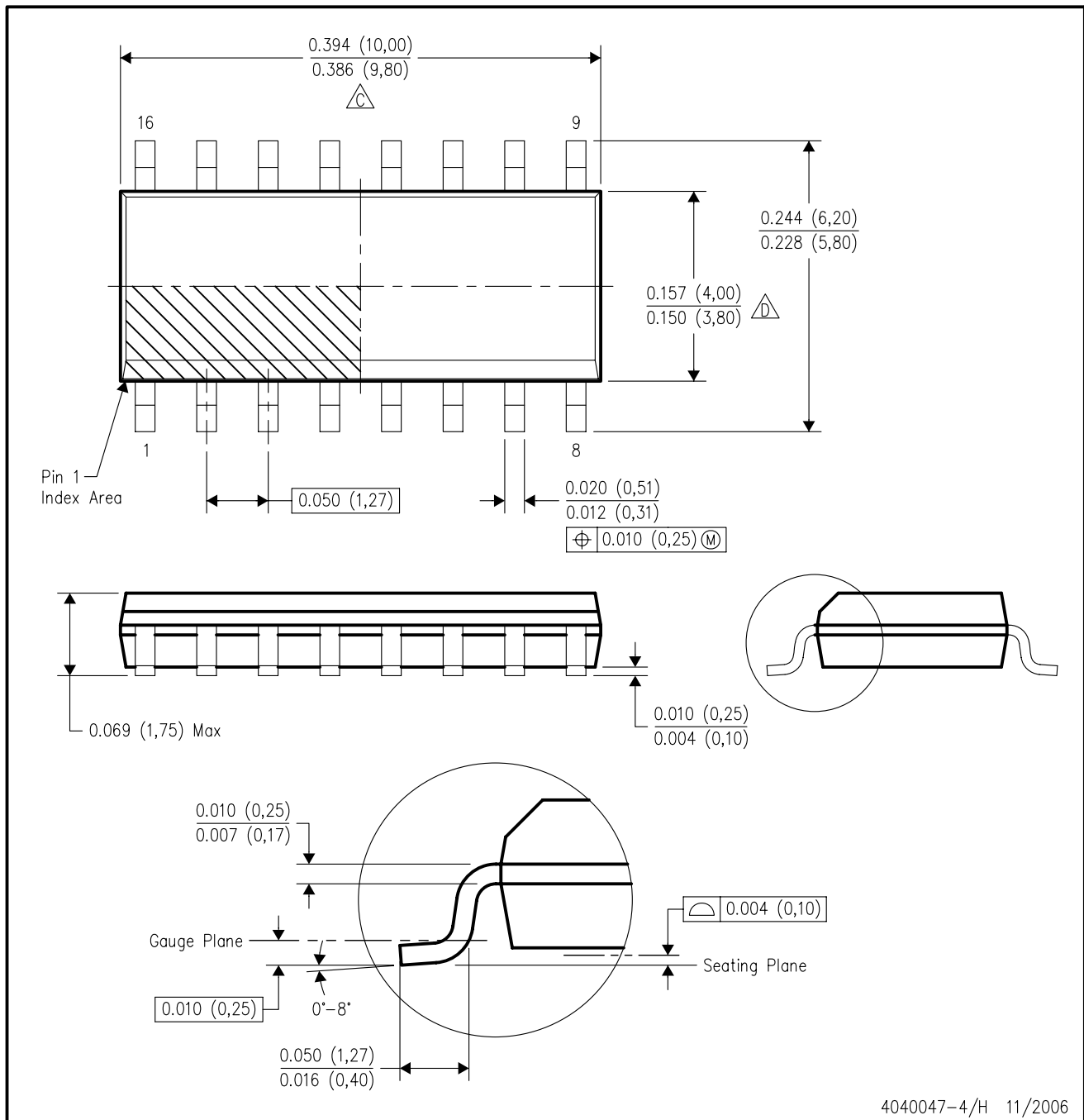

4040047-4/H 11/2006

- NOTES:
- A. All linear dimensions are in inches (millimeters).
  - B. This drawing is subject to change without notice.
  - C. Body length does not include mold flash, protrusions, or gate burrs. Mold flash, protrusions, or gate burrs shall not exceed .006 (0,15) per end.
  - D. Body width does not include interlead flash. Interlead flash shall not exceed .017 (0,43) per side.
  - E. Reference JEDEC MS-012 variation AC.

# MECHANICAL DATA

NS (R-PDSO-G\*\*)

PLASTIC SMALL-OUTLINE PACKAGE

14-PINS SHOWN



- NOTES:
- A. All linear dimensions are in millimeters.
  - B. This drawing is subject to change without notice.
  - C. Body dimensions do not include mold flash or protrusion, not to exceed 0,15.

## IMPORTANT NOTICE

Texas Instruments Incorporated and its subsidiaries (TI) reserve the right to make corrections, modifications, enhancements, improvements, and other changes to its products and services at any time and to discontinue any product or service without notice. Customers should obtain the latest relevant information before placing orders and should verify that such information is current and complete. All products are sold subject to TI's terms and conditions of sale supplied at the time of order acknowledgment.

TI warrants performance of its hardware products to the specifications applicable at the time of sale in accordance with TI's standard warranty. Testing and other quality control techniques are used to the extent TI deems necessary to support this warranty. Except where mandated by government requirements, testing of all parameters of each product is not necessarily performed.

TI assumes no liability for applications assistance or customer product design. Customers are responsible for their products and applications using TI components. To minimize the risks associated with customer products and applications, customers should provide adequate design and operating safeguards.

TI does not warrant or represent that any license, either express or implied, is granted under any TI patent right, copyright, mask work right, or other TI intellectual property right relating to any combination, machine, or process in which TI products or services are used. Information published by TI regarding third-party products or services does not constitute a license from TI to use such products or services or a warranty or endorsement thereof. Use of such information may require a license from a third party under the patents or other intellectual property of the third party, or a license from TI under the patents or other intellectual property of TI.

Reproduction of information in TI data books or data sheets is permissible only if reproduction is without alteration and is accompanied by all associated warranties, conditions, limitations, and notices. Reproduction of this information with alteration is an unfair and deceptive business practice. TI is not responsible or liable for such altered documentation.

Resale of TI products or services with statements different from or beyond the parameters stated by TI for that product or service voids all express and any implied warranties for the associated TI product or service and is an unfair and deceptive business practice. TI is not responsible or liable for any such statements.

Following are URLs where you can obtain information on other Texas Instruments products and application solutions:

<b>Products</b>		<b>Applications</b>	
Amplifiers	<a href="http://amplifier.ti.com">amplifier.ti.com</a>	Audio	<a href="http://www.ti.com/audio">www.ti.com/audio</a>
Data Converters	<a href="http://dataconverter.ti.com">dataconverter.ti.com</a>	Automotive	<a href="http://www.ti.com/automotive">www.ti.com/automotive</a>
DSP	<a href="http://dsp.ti.com">dsp.ti.com</a>	Broadband	<a href="http://www.ti.com/broadband">www.ti.com/broadband</a>
Interface	<a href="http://interface.ti.com">interface.ti.com</a>	Digital Control	<a href="http://www.ti.com/digitalcontrol">www.ti.com/digitalcontrol</a>
Logic	<a href="http://logic.ti.com">logic.ti.com</a>	Military	<a href="http://www.ti.com/military">www.ti.com/military</a>
Power Mgmt	<a href="http://power.ti.com">power.ti.com</a>	Optical Networking	<a href="http://www.ti.com/opticalnetwork">www.ti.com/opticalnetwork</a>
Microcontrollers	<a href="http://microcontroller.ti.com">microcontroller.ti.com</a>	Security	<a href="http://www.ti.com/security">www.ti.com/security</a>
Low Power Wireless	<a href="http://www.ti.com/lpw">www.ti.com/lpw</a>	Telephony	<a href="http://www.ti.com/telephony">www.ti.com/telephony</a>
		Video & Imaging	<a href="http://www.ti.com/video">www.ti.com/video</a>
		Wireless	<a href="http://www.ti.com/wireless">www.ti.com/wireless</a>

Mailing Address: Texas Instruments  
Post Office Box 655303 Dallas, Texas 75265