

SN54AS1000A, SN74AS1000A QUADRUPLE 2-INPUT POSITIVE-NAND BUFFERS/DRIVERS

SDAS056B – APRIL 1984 – REVISED JANUARY 1995

- Driver Version of 'AS00
- High Capacitive-Drive Capability
- Package Options Include Plastic Small-Outline (D) Packages, Ceramic Chip Carriers (FK), and Standard Plastic (N) and Ceramic (J) 300-mil DIPs

description

These devices contain four independent 2-input positive-NAND buffers/drivers. They perform the Boolean functions $Y = \overline{A \cdot B}$ or $Y = \overline{A} + \overline{B}$ in positive logic.

The SN54AS1000A is characterized for operation over the full military temperature range of -55°C to 125°C . The SN74AS1000A is characterized for operation from 0°C to 70°C .

FUNCTION TABLE
(each gate)

INPUTS		OUTPUT
A	B	Y
H	H	L
L	X	H
X	L	H

SN54AS1000A . . . J PACKAGE
SN74AS1000A . . . D OR N PACKAGE
(TOP VIEW)

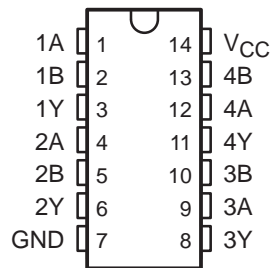

SN54AS1000A . . . FK PACKAGE
(TOP VIEW)

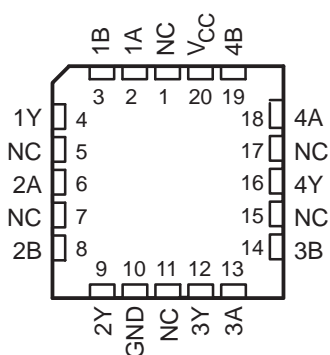

NC – No internal connection

logic symbol†

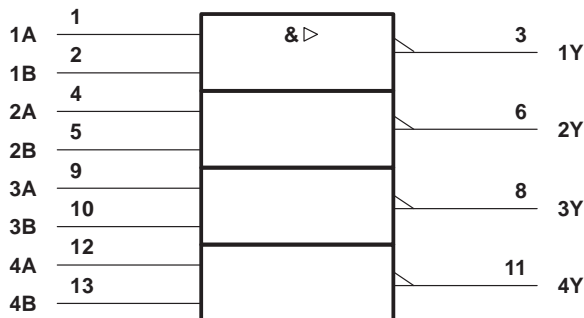

logic diagram (positive logic)

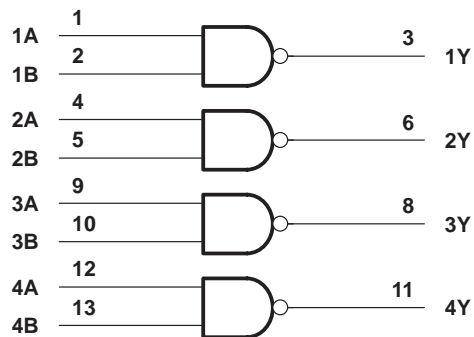

† This symbol is in accordance with ANSI/IEEE Std 91-1984 and IEC Publication 617-12.

Pin numbers shown are for the D, J, and N packages.

SN54AS1000A, SN74AS1000A QUADRUPLE 2-INPUT POSITIVE-NAND BUFFERS/DRIVERS

SDAS056B – APRIL 1984 – REVISED JANUARY 1995

absolute maximum ratings over operating free-air temperature range (unless otherwise noted)†

Supply voltage, V_{CC}	7 V
Input voltage, V_I	7 V
Operating free-air temperature range, T_A : SN54AS1000A	-55°C to 125°C
SN74AS1000A	0°C to 70°C
Storage temperature range	-65°C to 150°C

† Stresses beyond those listed under “absolute maximum ratings” may cause permanent damage to the device. These are stress ratings only, and functional operation of the device at these or any other conditions beyond those indicated under “recommended operating conditions” is not implied. Exposure to absolute-maximum-rated conditions for extended periods may affect device reliability.

recommended operating conditions‡

		SN54AS1000A			SN74AS1000A			UNIT
		MIN	NOM	MAX	MIN	NOM	MAX	
V_{CC}	Supply voltage	4.5	5	5.5	4.5	5	5.5	V
V_{IH}	High-level input voltage	2			2			V
V_{IL}	Low-level input voltage			0.8			0.8	V
I_{OH}	High-level output current			-40			-48	mA
I_{OL}	Low-level output current			40			48	mA
T_A	Operating free-air temperature	-55		125	0		70	°C

‡ These high sink- or source-current devices are not recommended for use above 40 MHz.

electrical characteristics over recommended operating free-air temperature range (unless otherwise noted)

PARAMETER	TEST CONDITIONS	SN54AS1000A			SN74AS1000A			UNIT
		MIN	TYP§	MAX	MIN	TYP§	MAX	
V_{IK}	$V_{CC} = 4.5$ V, $I_I = -18$ mA			-1.2			-1.2	V
V_{OH}	$V_{CC} = 4.5$ V to 5.5 V, $I_{OH} = -2$ mA	$V_{CC} - 2$			$V_{CC} - 2$			V
	$V_{CC} = 4.5$ V, $I_{OH} = -3$ mA	2.4	3.2		2.4	3.2		
	$V_{CC} = 4.5$ V, $I_{OH} = -40$ mA	2						
V_{OL}	$V_{CC} = 4.5$ V, $I_{OH} = -48$ mA				2			V
	$V_{CC} = 4.5$ V, $I_{OL} = 40$ mA	0.25			0.5			
	$V_{CC} = 4.5$ V, $I_{OL} = 48$ mA				0.35			
I_I	$V_{CC} = 5.5$ V, $V_I = 7$ V			0.1			0.1	mA
I_{IH}	$V_{CC} = 5.5$ V, $V_I = 2.7$ V			20			20	μA
I_{IL}	$V_{CC} = 5.5$ V, $V_I = 0.4$ V			-0.5			-0.5	mA
I_{O}^{\parallel}	$V_{CC} = 5.5$ V, $V_O = 2.25$ V	-30		-200	-50		-200	mA
I_{CCH}	$V_{CC} = 5.5$ V, $V_I = 0$		2.2	3.5		2.2	3.5	mA
I_{CCL}	$V_{CC} = 5.5$ V, $V_I = 4.5$ V		12	19		12	19	mA

§ All typical values are at $V_{CC} = 5$ V, $T_A = 25^\circ\text{C}$.

¶ The output conditions have been chosen to produce a current that closely approximates one half of the true short-circuit output current, I_{OS} .

SN54AS1000A, SN74AS1000A QUADRUPLE 2-INPUT POSITIVE-NAND BUFFERS/DRIVERS

SDAS056B – APRIL 1984 – REVISED JANUARY 1995

switching characteristics (see Figure 1)

PARAMETER	FROM (INPUT)	TO (OUTPUT)	$V_{CC} = 4.5 \text{ V to } 5.5 \text{ V},$ $C_L = 50 \text{ pF},$ $R_L = 500 \Omega,$ $T_A = \text{MIN to MAX}^\dagger$				UNIT
			SN54AS1000A		SN74AS1000A		
			MIN	MAX	MIN	MAX	
t_{PLH}	A or B	Y	1	5	1	4	ns
t_{PHL}			1	5	1	4	

† For conditions shown as MIN or MAX, use the appropriate value specified under recommended operating conditions.

SN54AS1000A, SN74AS1000A QUADRUPLE 2-INPUT POSITIVE-NAND BUFFERS/DRIVERS

SDAS056B – APRIL 1984 – REVISED JANUARY 1995

PARAMETER MEASUREMENT INFORMATION SERIES 54ALS/74ALS AND 54AS/74AS DEVICES

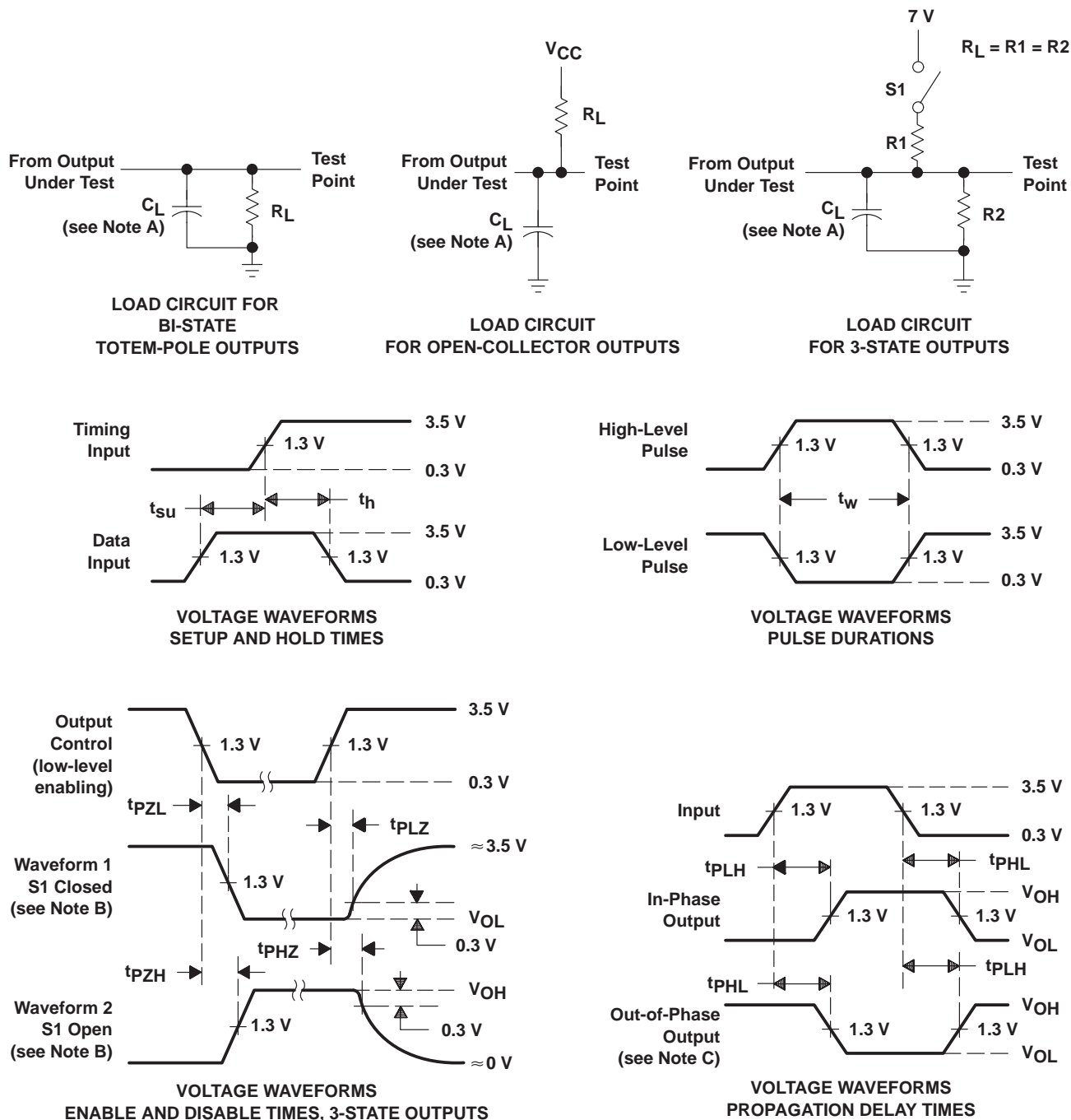

- NOTES: A. C_L includes probe and jig capacitance.
 B. Waveform 1 is for an output with internal conditions such that the output is low except when disabled by the output control. Waveform 2 is for an output with internal conditions such that the output is high except when disabled by the output control.
 C. When measuring propagation delay items of 3-state outputs, switch S1 is open.
 D. All input pulses have the following characteristics: $PRR \leq 1$ MHz, $t_r = t_f = 2$ ns, duty cycle = 50%.
 E. The outputs are measured one at a time with one transition per measurement.

Figure 1. Load Circuits and Voltage Waveforms

IMPORTANT NOTICE

Texas Instruments and its subsidiaries (TI) reserve the right to make changes to their products or to discontinue any product or service without notice, and advise customers to obtain the latest version of relevant information to verify, before placing orders, that information being relied on is current and complete. All products are sold subject to the terms and conditions of sale supplied at the time of order acknowledgement, including those pertaining to warranty, patent infringement, and limitation of liability.

TI warrants performance of its semiconductor products to the specifications applicable at the time of sale in accordance with TI's standard warranty. Testing and other quality control techniques are utilized to the extent TI deems necessary to support this warranty. Specific testing of all parameters of each device is not necessarily performed, except those mandated by government requirements.

CERTAIN APPLICATIONS USING SEMICONDUCTOR PRODUCTS MAY INVOLVE POTENTIAL RISKS OF DEATH, PERSONAL INJURY, OR SEVERE PROPERTY OR ENVIRONMENTAL DAMAGE ("CRITICAL APPLICATIONS"). TI SEMICONDUCTOR PRODUCTS ARE NOT DESIGNED, AUTHORIZED, OR WARRANTED TO BE SUITABLE FOR USE IN LIFE-SUPPORT DEVICES OR SYSTEMS OR OTHER CRITICAL APPLICATIONS. INCLUSION OF TI PRODUCTS IN SUCH APPLICATIONS IS UNDERSTOOD TO BE FULLY AT THE CUSTOMER'S RISK.

In order to minimize risks associated with the customer's applications, adequate design and operating safeguards must be provided by the customer to minimize inherent or procedural hazards.

TI assumes no liability for applications assistance or customer product design. TI does not warrant or represent that any license, either express or implied, is granted under any patent right, copyright, mask work right, or other intellectual property right of TI covering or relating to any combination, machine, or process in which such semiconductor products or services might be or are used. TI's publication of information regarding any third party's products or services does not constitute TI's approval, warranty or endorsement thereof.