

SN54ALVTH16827, SN74ALVTH16827 2.5-V/3.3-V 20-BIT BUFFERS/DRIVERS WITH 3-STATE OUTPUTS

SCES076E – JULY 1996 – REVISED DECEMBER 1998

- State-of-the-Art Advanced BiCMOS Technology (ABT) *Widebus*™ Design for 2.5-V and 3.3-V Operation and Low Static Power Dissipation
- Support Mixed-Mode Signal Operation (5-V Input and Output Voltages With 2.3-V to 3.6-V V_{CC})
- Typical V_{OLP} (Output Ground Bounce) < 0.8 V at $V_{CC} = 3.3$ V, $T_A = 25^\circ\text{C}$
- High Drive (–24/24 mA at 2.5-V and –32/64 mA at 3.3-V V_{CC})
- Power Off Disables Outputs, Permitting Live Insertion
- High-Impedance State During Power Up and Power Down Prevents Driver Conflict
- Uses Bus Hold on Data Inputs in Place of External Pullup/Pulldown Resistors to Prevent the Bus From Floating
- Auto3-State Eliminates Bus Current Loading When Output Exceeds $V_{CC} + 0.5$ V
- Latch-Up Performance Exceeds 250 mA Per JESD 17
- ESD Protection Exceeds 2000 V Per MIL-STD-883, Method 3015; Exceeds 200 V Using Machine Model; and Exceeds 1000 V Using Charged-Device Model, Robotic Method
- Flow-Through Architecture Facilitates Printed Circuit Board Layout
- Distributed V_{CC} and GND Pin Configuration Minimizes High-Speed Switching Noise
- Package Options Include Plastic Shrink Small-Outline (DL), Thin Shrink Small-Outline (DGG), Thin Very Small-Outline (DGV) Packages, and 380-mil Fine-Pitch Ceramic Flat (WD) Package

SN54ALVTH16827 . . . WD PACKAGE
SN74ALVTH16827 . . . DGG, DGV, OR DL PACKAGE
(TOP VIEW)

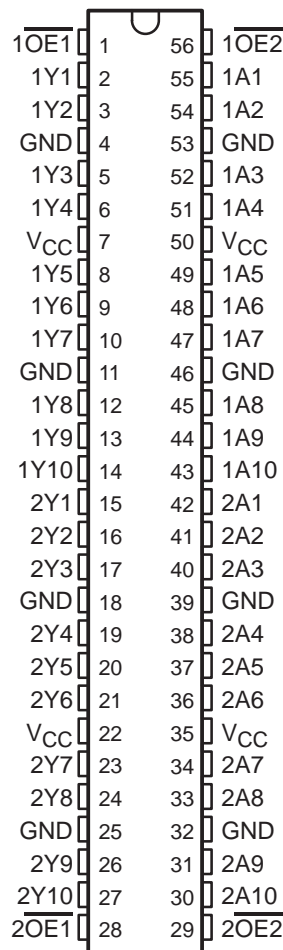

description

The 'ALVTH16827 devices are 20-bit buffers/line drivers designed for 2.5-V or 3.3-V V_{CC} operation, but with the capability to provide a TTL interface to a 5-V system environment.

The devices are composed of two 10-bit sections with separate output-enable signals. For either 10-bit buffer section, the two output-enable ($1\overline{OE}1$ and $1\overline{OE}2$, or $2\overline{OE}1$ and $2\overline{OE}2$) inputs must be low for the corresponding Y outputs to be active. If either output-enable input is high, the outputs of that 10-bit buffer section are in the high-impedance state.



Please be aware that an important notice concerning availability, standard warranty, and use in critical applications of Texas Instruments semiconductor products and disclaimers thereto appears at the end of this data sheet.

Widebus is a trademark of Texas Instruments Incorporated.

UNLESS OTHERWISE NOTED this document contains PRODUCTION DATA information current as of publication date. Products conform to specifications per the terms of Texas Instruments standard warranty. Production processing does not necessarily include testing of all parameters.

 **TEXAS
INSTRUMENTS**

POST OFFICE BOX 655303 • DALLAS, TEXAS 75265

Copyright © 1998, Texas Instruments Incorporated

SN54ALVTH16827, SN74ALVTH16827 2.5-V/3.3-V 20-BIT BUFFERS/DRIVERS WITH 3-STATE OUTPUTS

SCES076E – JULY 1996 – REVISED DECEMBER 1998

description (continued)

When V_{CC} is between 0 and 1.2 V, the device is in the high-impedance state during power up or power down. However, to ensure the high-impedance state above 1.2 V, \overline{OE} should be tied to V_{CC} through a pullup resistor; the minimum value of the resistor is determined by the current-sinking capability of the driver.

Active bus-hold circuitry is provided to hold unused or floating data inputs at a valid logic level.

The SN54ALVTH16827 is characterized for operation over the full military temperature range of -55°C to 125°C . The SN74ALVTH16827 is characterized for operation from -40°C to 85°C .

FUNCTION TABLE
(each 10-bit section)

INPUTS			OUTPUT
$\overline{OE1}$	$\overline{OE2}$	A	Y
L	L	L	L
L	L	H	H
H	X	X	Z
X	H	X	Z

logic diagram (positive logic)

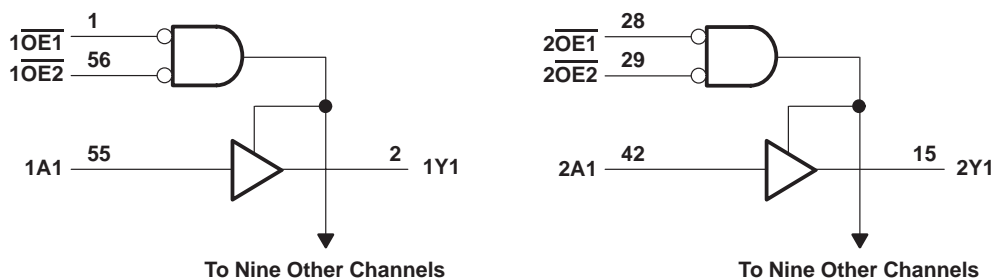

absolute maximum ratings over operating free-air temperature range (unless otherwise noted)†

Supply voltage range, V_{CC}	$-0.5\text{ V to }4.6\text{ V}$
Input voltage range, V_I (see Note 1)	$-0.5\text{ V to }7\text{ V}$
Voltage range applied to any output in the high-impedance or power-off state, V_O (see Note 1)	$-0.5\text{ V to }7\text{ V}$
Voltage range applied to any output in the high state, V_O (see Note 1)	$-0.5\text{ V to }7\text{ V}$
Output current in the low state, I_O : SN54ALVTH16827	96 mA
SN74ALVTH16827	128 mA
Output current in the high state, I_O : SN54ALVTH16827	-48 mA
SN74ALVTH16827	-64 mA
Input clamp current, I_{IK} ($V_I < 0$)	-50 mA
Output clamp current, I_{OK} ($V_O < 0$)	-50 mA
Package thermal impedance, θ_{JA} (see Note 2): DGG package	81°C/W
DGV package	86°C/W
DL package	74°C/W
Storage temperature range, T_{stg}	$-65^{\circ}\text{C to }150^{\circ}\text{C}$

† Stresses beyond those listed under “absolute maximum ratings” may cause permanent damage to the device. These are stress ratings only, and functional operation of the device at these or any other conditions beyond those indicated under “recommended operating conditions” is not implied. Exposure to absolute-maximum-rated conditions for extended periods may affect device reliability.

NOTES: 1. The input and output negative-voltage ratings may be exceeded if the input and output clamp-current ratings are observed.
2. The package thermal impedance is calculated in accordance with JESD 51.



POST OFFICE BOX 655303 • DALLAS, TEXAS 75265

SN54ALVTH16827, SN74ALVTH16827 2.5-V/3.3-V 20-BIT BUFFERS/DRIVERS WITH 3-STATE OUTPUTS

SCES076E – JULY 1996 – REVISED DECEMBER 1998

recommended operating conditions, $V_{CC} = 2.5\text{ V} \pm 0.2\text{ V}$ (see Note 3)

		SN54ALVTH16827			SN74ALVTH16827			UNIT
		MIN	TYP	MAX	MIN	TYP	MAX	
V_{CC}	Supply voltage	2.3		2.7	2.3		2.7	V
V_{IH}	High-level input voltage	1.7			1.7			V
V_{IL}	Low-level input voltage			0.7			0.7	V
V_I	Input voltage	0	V_{CC}	5.5	0	V_{CC}	5.5	V
I_{OH}	High-level output current			-6			-8	mA
I_{OL}	Low-level output current			6			8	mA
	Low-level output current; current duty cycle $\leq 50\%$; $f \geq 1\text{ kHz}$			18			24	
$\Delta t/\Delta v$	Input transition rise or fall rate			10			10	ns/V
$\Delta t/\Delta V_{CC}$	Power-up ramp rate	200			200			$\mu\text{s/V}$
T_A	Operating free-air temperature	-55		125	-40		85	$^{\circ}\text{C}$

NOTE 3: All unused control inputs of the device must be held at V_{CC} or GND to ensure proper device operation. Refer to the TI application report, *Implications of Slow or Floating CMOS Inputs*, literature number SCBA004.

recommended operating conditions, $V_{CC} = 3.3\text{ V} \pm 0.3\text{ V}$ (see Note 3)

		SN54ALVTH16827			SN74ALVTH16827			UNIT
		MIN	TYP	MAX	MIN	TYP	MAX	
V_{CC}	Supply voltage	3		3.6	3		3.6	V
V_{IH}	High-level input voltage	2			2			V
V_{IL}	Low-level input voltage			0.8			0.8	V
V_I	Input voltage	0	V_{CC}	5.5	0	V_{CC}	5.5	V
I_{OH}	High-level output current			-24			-32	mA
I_{OL}	Low-level output current			24			32	mA
	Low-level output current; current duty cycle $\leq 50\%$; $f \geq 1\text{ kHz}$			48			64	
$\Delta t/\Delta v$	Input transition rise or fall rate			10			10	ns/V
$\Delta t/\Delta V_{CC}$	Power-up ramp rate	200			200			$\mu\text{s/V}$
T_A	Operating free-air temperature	-55		125	-40		85	$^{\circ}\text{C}$

NOTE 3: All unused control inputs of the device must be held at V_{CC} or GND to ensure proper device operation. Refer to the TI application report, *Implications of Slow or Floating CMOS Inputs*, literature number SCBA004.

SN54ALVTH16827, SN74ALVTH16827
2.5-V/3.3-V 20-BIT BUFFERS/DRIVERS
WITH 3-STATE OUTPUTS

SCES076E – JULY 1996 – REVISED DECEMBER 1998

electrical characteristics over recommended operating free-air temperature range,
 $V_{CC} = 2.5\text{ V} \pm 0.2\text{ V}$ (unless otherwise noted)

PARAMETER	TEST CONDITIONS	SN54ALVTH16827		SN74ALVTH16827		UNIT		
		MIN	TYP†	MAX	MIN		TYP†	MAX
V_{IK}	$V_{CC} = 2.3\text{ V}$, $I_I = -18\text{ mA}$			-1.2		-1.2	V	
V_{OH}	$V_{CC} = 2.3\text{ V to } 2.7\text{ V}$, $I_{OH} = -100\text{ }\mu\text{A}$	$V_{CC}-0.2$		$V_{CC}-0.2$			V	
	$V_{CC} = 2.3\text{ V}$	1.8		1.8				
V_{OL}	$V_{CC} = 2.3\text{ V to } 2.7\text{ V}$, $I_{OL} = 100\text{ }\mu\text{A}$			0.2	0.2		V	
	$V_{CC} = 2.3\text{ V}$	$I_{OL} = 6\text{ mA}$		0.4	0.47			
		$I_{OL} = 8\text{ mA}$			0.4			
		$I_{OL} = 18\text{ mA}$		0.5				
		$I_{OL} = 24\text{ mA}$			0.5			
I_I	Control inputs	$V_{CC} = 2.7\text{ V}$, $V_I = V_{CC}$ or GND			± 1	± 1	μA	
		$V_{CC} = 0$ or 2.7 V , $V_I = 5.5\text{ V}$			10	10		
	Data inputs	$V_{CC} = 2.7\text{ V}$	$V_I = 5.5\text{ V}$		10			
			$V_I = V_{CC}$		1			
		$V_I = 0$		-5				
I_{off}	$V_{CC} = 0$, V_I or $V_O = 0$ to 4.5 V				± 100		μA	
I_{BHL}^\ddagger	$V_{CC} = 2.3\text{ V}$, $V_I = 0.7\text{ V}$	115		115		μA		
I_{BHH}^\S	$V_{CC} = 2.3\text{ V}$, $V_I = 1.7\text{ V}$	-10		-10		μA		
I_{BHLO}^\P	$V_{CC} = 2.7\text{ V}$, $V_I = 0$ to V_{CC}	300		300		μA		
$I_{BHHO}^\#$	$V_{CC} = 2.7\text{ V}$, $V_I = 0$ to V_{CC}	-300		-300		μA		
I_{EX}^\parallel	$V_{CC} = 2.3\text{ V}$, $V_O = 5.5\text{ V}$			125	125		μA	
$I_{OZ(PU/PD)}^*$	$V_{CC} \leq 1.2\text{ V}$, $V_O = 0.5\text{ V to } V_{CC}$, $V_I = \text{GND or } V_{CC}$, $\overline{OE} = \text{don't care}$			± 100	± 100		μA	
I_{OZH}	$V_{CC} = 2.7\text{ V}$	$V_O = 2.3\text{ V}$, $V_I = 0.7\text{ V or } 1.7\text{ V}$		5		5	μA	
I_{OZL}	$V_{CC} = 2.7\text{ V}$	$V_O = 0.5\text{ V}$, $V_I = 0.7\text{ V or } 1.7\text{ V}$		-5		-5	μA	
I_{CC}	$V_{CC} = 2.7\text{ V}$, $I_O = 0$, $V_I = V_{CC}$ or GND	Outputs high		0.04	0.1	0.04	0.1	mA
		Outputs low		2.3	5	2.3	5	
		Outputs disabled		0.04	0.1	0.04	0.1	
C_i	$V_{CC} = 2.5\text{ V}$, $V_I = 2.5\text{ V or } 0$			3		3	pF	
C_o	$V_{CC} = 2.5\text{ V}$, $V_O = 2.5\text{ V or } 0$			6		6	pF	

† All typical values are at $V_{CC} = 2.5\text{ V}$, $T_A = 25^\circ\text{C}$.

‡ The bus-hold circuit can sink at least the minimum low sustaining current at V_{IL} max. I_{BHL} should be measured after lowering V_{IN} to GND and then raising it to V_{IL} max.

§ The bus-hold circuit can source at least the minimum high sustaining current at V_{IH} min. I_{BHH} should be measured after raising V_{IN} to V_{CC} and then lowering it to V_{IH} min.

¶ An external driver must source at least I_{BHLO} to switch this node from low to high.

An external driver must sink at least I_{BHHO} to switch this node from high to low.

|| Current into an output in the high state when $V_O > V_{CC}$

* High-impedance state during power up or power down

SN54ALVTH16827, SN74ALVTH16827
2.5-V/3.3-V 20-BIT BUFFERS/DRIVERS
WITH 3-STATE OUTPUTS

SCES076E – JULY 1996 – REVISED DECEMBER 1998

electrical characteristics over recommended operating free-air temperature range,
 $V_{CC} = 3.3 \text{ V} \pm 0.3 \text{ V}$ (unless otherwise noted)

PARAMETER		TEST CONDITIONS		SN54ALVTH16827		SN74ALVTH16827		UNIT		
				MIN	TYP†	MAX	MIN		TYP†	MAX
V_{IK}		$V_{CC} = 3 \text{ V}$, $I_I = -18 \text{ mA}$		-1.2		-1.2		V		
V_{OH}		$V_{CC} = 3 \text{ V to } 3.6 \text{ V}$, $I_{OH} = -100 \mu\text{A}$		$V_{CC}-0.2$		$V_{CC}-0.2$		V		
		$V_{CC} = 3 \text{ V}$		2		2				
V_{OL}		$V_{CC} = 3 \text{ V to } 3.6 \text{ V}$, $I_{OL} = 100 \mu\text{A}$		0.2		0.2		V		
		$V_{CC} = 3 \text{ V}$		$I_{OL} = 16 \text{ mA}$		0.4				
				$I_{OL} = 24 \text{ mA}$		0.5				
				$I_{OL} = 32 \text{ mA}$		0.5				
				$I_{OL} = 48 \text{ mA}$		0.55				
$I_{OL} = 64 \text{ mA}$				0.55						
I_I		Control inputs $V_{CC} = 3.6 \text{ V}$, $V_I = V_{CC}$ or GND		± 1		± 1		μA		
				$V_{CC} = 0$ or 3.6 V , $V_I = 5.5 \text{ V}$		10			10	
		Data inputs $V_{CC} = 3.6 \text{ V}$		$V_I = 5.5 \text{ V}$		10			10	
				$V_I = V_{CC}$		1			1	
		$V_I = 0$		-5		-5				
I_{off}		$V_{CC} = 0$, V_I or $V_O = 0$ to 4.5 V				± 100		μA		
I_{BHL}^\ddagger		$V_{CC} = 3 \text{ V}$, $V_I = 0.8 \text{ V}$		75		75		μA		
I_{BHH}^\S		$V_{CC} = 3 \text{ V}$, $V_I = 2 \text{ V}$		-75		-75		μA		
I_{BHLO}^\P		$V_{CC} = 3.6 \text{ V}$, $V_I = 0$ to V_{CC}		500		500		μA		
$I_{BHHO}^\#$		$V_{CC} = 3.6 \text{ V}$, $V_I = 0$ to V_{CC}		-500		-500		μA		
I_{EX}^\parallel		$V_{CC} = 3 \text{ V}$, $V_O = 5.5 \text{ V}$		125		125		μA		
$I_{OZ}(\text{PU/PD})^\star$		$V_{CC} \leq 1.2 \text{ V}$, $V_O = 0.5 \text{ V to } V_{CC}$, $V_I = \text{GND or } V_{CC}$, $\text{OE} = \text{don't care}$		± 100		± 100		μA		
I_{OZH}		$V_{CC} = 3.6 \text{ V}$, $V_O = 3 \text{ V}$, $V_I = 0.8 \text{ V or } 2 \text{ V}$		5		5		μA		
I_{OZL}		$V_{CC} = 3.6 \text{ V}$, $V_O = 0.5 \text{ V}$, $V_I = 0.8 \text{ V or } 2 \text{ V}$		-5		-5		μA		
I_{CC}		$V_{CC} = 3.6 \text{ V}$, $I_O = 0$, $V_I = V_{CC}$ or GND		Outputs high		0.07 0.1		mA		
				Outputs low		3.2 6				
				Outputs disabled		0.07 0.1				
ΔI_{CC}^\square		$V_{CC} = 3 \text{ V to } 3.6 \text{ V}$, One input at $V_{CC} - 0.6 \text{ V}$, Other inputs at V_{CC} or GND		0.4		0.4		mA		
C_i		$V_{CC} = 3.3 \text{ V}$, $V_I = 3.3 \text{ V or } 0$		3		3		pF		
C_o		$V_{CC} = 3.3 \text{ V}$, $V_O = 3.3 \text{ V or } 0$		6		6		pF		

† All typical values are at $V_{CC} = 3.3 \text{ V}$, $T_A = 25^\circ\text{C}$.

‡ The bus-hold circuit can sink at least the minimum low sustaining current at V_{IL} max. I_{BHL} should be measured after lowering V_{IN} to GND and then raising it to V_{IL} max.

§ The bus-hold circuit can source at least the minimum high sustaining current at V_{IH} min. I_{BHH} should be measured after raising V_{IN} to V_{CC} and then lowering it to V_{IH} min.

¶ An external driver must source at least I_{BHLO} to switch this node from low to high.

An external driver must sink at least I_{BHHO} to switch this node from high to low.

|| Current into an output in the high state when $V_O > V_{CC}$

☆ High-impedance state during power up or power down

□ This is the increase in supply current for each input that is at the specified TTL voltage level rather than V_{CC} or GND.

PRODUCT PREVIEW information concerns products in the formative or design phase of development. Characteristic data and other specifications are design goals. Texas Instruments reserves the right to change or discontinue these products without notice.



SN54ALVTH16827, SN74ALVTH16827
2.5-V/3.3-V 20-BIT BUFFERS/DRIVERS
WITH 3-STATE OUTPUTS

SCES076E – JULY 1996 – REVISED DECEMBER 1998

switching characteristics over recommended operating free-air temperature range, $C_L = 30 \text{ pF}$, $V_{CC} = 2.5 \text{ V} \pm 0.2 \text{ V}$ (unless otherwise noted) (see Figure 1)

PARAMETER	FROM (INPUT)	TO (OUTPUT)	SN54ALVTH16827		SN74ALVTH16827		UNIT
			MIN	MAX	MIN	MAX	
t_{PLH}	A	Y	1.5	3.2	1.5	3.2	ns
t_{PHL}			1.7	3.7	1.7	3.7	
t_{PZH}	\overline{OE}	Y	1.9	4.3	1.9	4.3	ns
t_{PZL}			1.8	4	1.8	4	
t_{PHZ}	\overline{OE}	Y	2.5	5.6	2.5	5.6	ns
t_{PLZ}			1.7	4.6	1.7	4.6	

switching characteristics over recommended operating free-air temperature range, $C_L = 50 \text{ pF}$, $V_{CC} = 3.3 \text{ V} \pm 0.3 \text{ V}$ (unless otherwise noted) (see Figure 2)

PARAMETER	FROM (INPUT)	TO (OUTPUT)	SN54ALVTH16827		SN74ALVTH16827		UNIT
			MIN	MAX	MIN	MAX	
t_{PLH}	A	Y	1.8	3	1.8	3	ns
t_{PHL}			1.6	2.8	1.6	2.8	
t_{PZH}	\overline{OE}	Y	1.6	3.9	1.6	3.9	ns
t_{PZL}			1.5	3.4	1.5	3.4	
t_{PHZ}	\overline{OE}	Y	3.3	5.8	3.3	5.8	ns
t_{PLZ}			2.6	4.6	2.6	4.6	

PRODUCT PREVIEW information concerns products in the formative or design phase of development. Characteristic data and other specifications are design goals. Texas Instruments reserves the right to change or discontinue these products without notice.



POST OFFICE BOX 655303 • DALLAS, TEXAS 75265

PARAMETER MEASUREMENT INFORMATION

$V_{CC} = 2.5\text{ V} \pm 0.2\text{ V}$

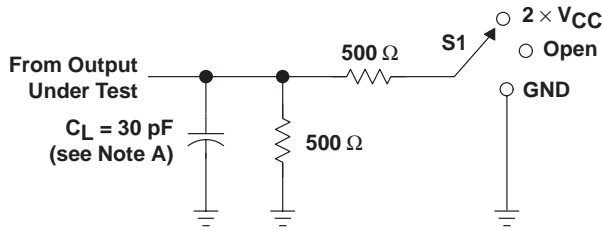

LOAD CIRCUIT

TEST	S1
t_{PLH}/t_{PHL}	Open
t_{PLZ}/t_{PZL}	$2 \times V_{CC}$
t_{PHZ}/t_{PZH}	GND

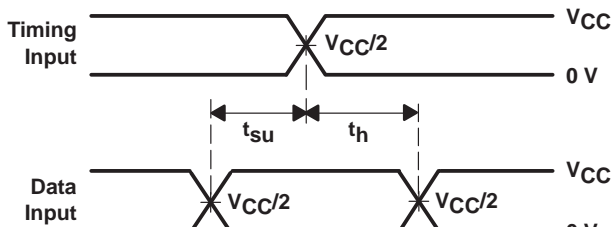

VOLTAGE WAVEFORMS
SETUP AND HOLD TIMES

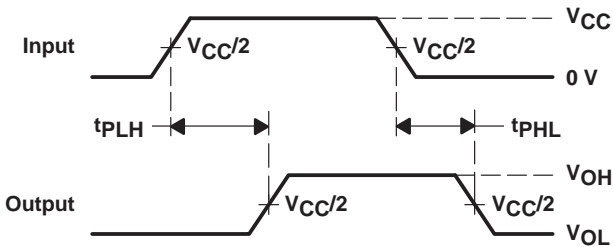

VOLTAGE WAVEFORMS
PROPAGATION DELAY TIMES

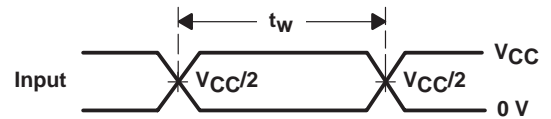

VOLTAGE WAVEFORMS
PULSE DURATION

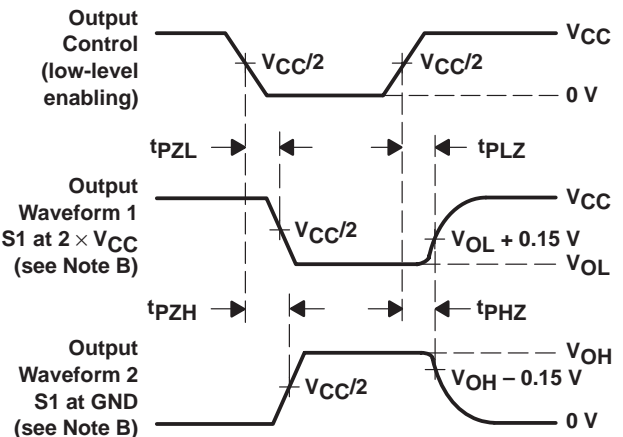

VOLTAGE WAVEFORMS
ENABLE AND DISABLE TIMES

- NOTES: A. C_L includes probe and jig capacitance.
B. Waveform 1 is for an output with internal conditions such that the output is low except when disabled by the output control. Waveform 2 is for an output with internal conditions such that the output is high except when disabled by the output control.
C. All input pulses are supplied by generators having the following characteristics: PRR $\leq 10\text{ MHz}$, $Z_O = 50\ \Omega$, $t_r \leq 2\text{ ns}$, $t_f \leq 2\text{ ns}$.
D. The outputs are measured one at a time with one transition per measurement.

Figure 1. Load Circuit and Voltage Waveforms

SN54ALVTH16827, SN74ALVTH16827
2.5-V/3.3-V 20-BIT BUFFERS/DRIVERS
WITH 3-STATE OUTPUTS

SCES076E – JULY 1996 – REVISED DECEMBER 1998

PARAMETER MEASUREMENT INFORMATION

$V_{CC} = 3.3\text{ V} \pm 0.3\text{ V}$

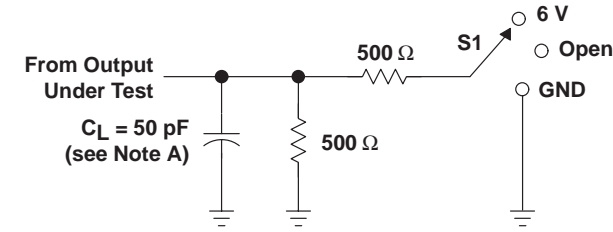

LOAD CIRCUIT

TEST	S1
t_{PLH}/t_{PHL}	Open
t_{PLZ}/t_{PZL}	6 V
t_{PHZ}/t_{PZH}	GND

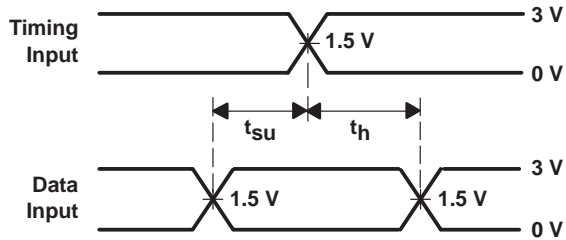

**VOLTAGE WAVEFORMS
 SETUP AND HOLD TIMES**

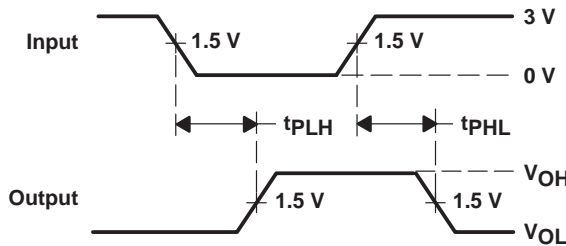

**VOLTAGE WAVEFORMS
 PROPAGATION DELAY TIMES
 INVERTING AND NONINVERTING OUTPUTS**

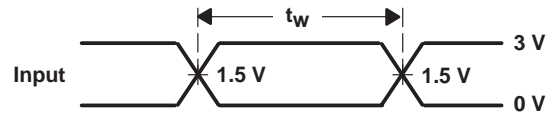

**VOLTAGE WAVEFORMS
 PULSE DURATION**

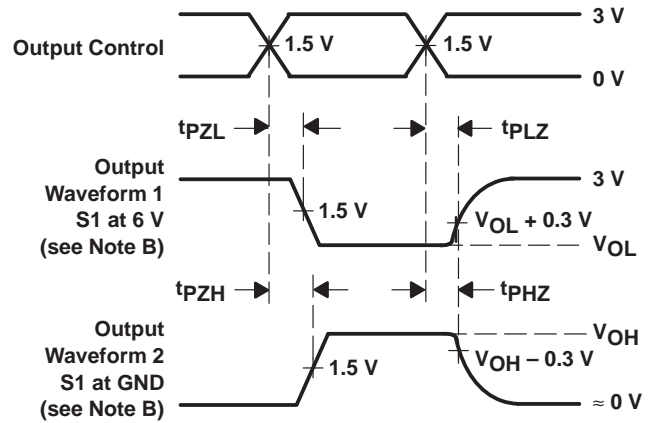

**VOLTAGE WAVEFORMS
 ENABLE AND DISABLE TIMES
 LOW- AND HIGH-LEVEL ENABLING**

- NOTES: A. C_L includes probe and jig capacitance.
 B. Waveform 1 is for an output with internal conditions such that the output is low except when disabled by the output control. Waveform 2 is for an output with internal conditions such that the output is high except when disabled by the output control.
 C. All input pulses are supplied by generators having the following characteristics: $PRR \leq 10\text{ MHz}$, $Z_O = 50\ \Omega$, $t_r \leq 2.5\text{ ns}$, $t_f \leq 2.5\text{ ns}$.
 D. The outputs are measured one at a time with one transition per measurement.

Figure 2. Load Circuit and Voltage Waveforms

IMPORTANT NOTICE

Texas Instruments and its subsidiaries (TI) reserve the right to make changes to their products or to discontinue any product or service without notice, and advise customers to obtain the latest version of relevant information to verify, before placing orders, that information being relied on is current and complete. All products are sold subject to the terms and conditions of sale supplied at the time of order acknowledgement, including those pertaining to warranty, patent infringement, and limitation of liability.

TI warrants performance of its semiconductor products to the specifications applicable at the time of sale in accordance with TI's standard warranty. Testing and other quality control techniques are utilized to the extent TI deems necessary to support this warranty. Specific testing of all parameters of each device is not necessarily performed, except those mandated by government requirements.

CERTAIN APPLICATIONS USING SEMICONDUCTOR PRODUCTS MAY INVOLVE POTENTIAL RISKS OF DEATH, PERSONAL INJURY, OR SEVERE PROPERTY OR ENVIRONMENTAL DAMAGE ("CRITICAL APPLICATIONS"). TI SEMICONDUCTOR PRODUCTS ARE NOT DESIGNED, AUTHORIZED, OR WARRANTED TO BE SUITABLE FOR USE IN LIFE-SUPPORT DEVICES OR SYSTEMS OR OTHER CRITICAL APPLICATIONS. INCLUSION OF TI PRODUCTS IN SUCH APPLICATIONS IS UNDERSTOOD TO BE FULLY AT THE CUSTOMER'S RISK.

In order to minimize risks associated with the customer's applications, adequate design and operating safeguards must be provided by the customer to minimize inherent or procedural hazards.

TI assumes no liability for applications assistance or customer product design. TI does not warrant or represent that any license, either express or implied, is granted under any patent right, copyright, mask work right, or other intellectual property right of TI covering or relating to any combination, machine, or process in which such semiconductor products or services might be or are used. TI's publication of information regarding any third party's products or services does not constitute TI's approval, warranty or endorsement thereof.