

SN54ALVTH162827, SN74ALVTH162827 2.5-V/3.3-V 20-BIT BUFFERS/DRIVERS WITH 3-STATE OUTPUTS

SCES079E – JULY 1996 – REVISED DECEMBER 1998

- State-of-the-Art Advanced BiCMOS Technology (ABT) *Widebus*™ Design for 2.5-V and 3.3-V Operation and Low Static Power Dissipation
- Support Mixed-Mode Signal Operation (5-V Input and Output Voltages With 2.3-V to 3.6-V V_{CC})
- Typical V_{OLP} (Output Ground Bounce) <0.8 V at $V_{CC} = 3.3$ V, $T_A = 25^\circ\text{C}$
- Power Off Disables Outputs, Permitting Live Insertion
- High-Impedance State During Power Up and Power Down Prevents Driver Conflict
- Uses Bus Hold on Data Inputs in Place of External Pullup/Pulldown Resistors to Prevent the Bus From Floating
- Output Ports Have Equivalent 30- Ω Series Resistors, So No External Resistors Are Required
- Auto3-State Eliminates Bus Current Loading When Output Exceeds $V_{CC} + 0.5$ V
- Latch-Up Performance Exceeds 250 mA Per JESD 17
- ESD Protection Exceeds 2000 V Per MIL-STD-883, Method 3015; Exceeds 200 V Using Machine Model; and Exceeds 1000 V Using Charged-Device Model, Robotic Method
- Flow-Through Architecture Facilitates Printed Circuit Board Layout
- Distributed V_{CC} and GND Pin Configuration Minimizes High-Speed Switching Noise
- Package Options Include Plastic Shrink Small-Outline (DL), Thin Shrink Small-Outline (DGG), Thin Very Small-Outline (DGV) Packages, and 380-mil Fine-Pitch Ceramic Flat (WD) Package

SN54ALVTH162827 . . . WD PACKAGE
SN74ALVTH162827 . . . DGG, DGV, OR DL PACKAGE
(TOP VIEW)

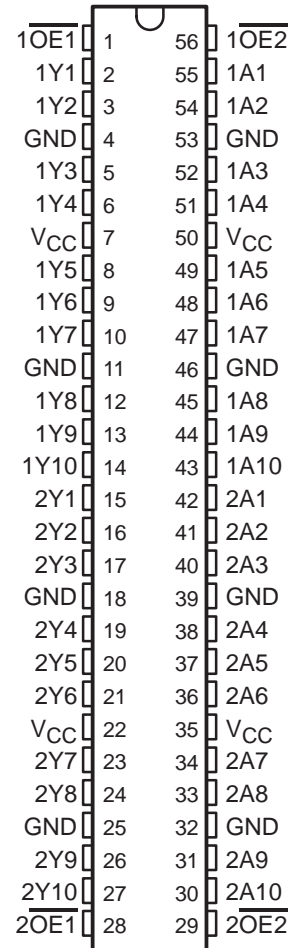

NOTE: For order entry:
The DGG package is abbreviated to G, and
the DGV package is abbreviated to V.

description

The 'ALVTH162827 devices are 20-bit buffers/line drivers designed for 2.5-V or 3.3-V V_{CC} operation, but with the capability to provide a TTL interface to a 5-V system environment.



Please be aware that an important notice concerning availability, standard warranty, and use in critical applications of Texas Instruments semiconductor products and disclaimers thereto appears at the end of this data sheet.

Widebus is a trademark of Texas Instruments Incorporated.

UNLESS OTHERWISE NOTED this document contains PRODUCTION DATA information current as of publication date. Products conform to specifications per the terms of Texas Instruments standard warranty. Production processing does not necessarily include testing of all parameters.

 **TEXAS
INSTRUMENTS**

POST OFFICE BOX 655303 • DALLAS, TEXAS 75265

Copyright © 1998, Texas Instruments Incorporated

SN54ALVTH162827, SN74ALVTH162827

2.5-V/3.3-V 20-BIT BUFFERS/DRIVERS

WITH 3-STATE OUTPUTS

SCES079E – JULY 1996 – REVISED DECEMBER 1998

description (continued)

The devices are composed of two 10-bit sections with separate output-enable signals. For either 10-bit buffer section, the two output-enable ($\overline{1OE1}$ and $\overline{1OE2}$, or $\overline{2OE1}$ and $\overline{2OE2}$) inputs must be low for the corresponding Y outputs to be active. If either output-enable input is high, the outputs of that 10-bit buffer section are in the high-impedance state.

When V_{CC} is between 0 and 1.2 V, the device is in the high-impedance state during power up or power down. However, to ensure the high-impedance state above 1.2 V, \overline{OE} should be tied to V_{CC} through a pullup resistor; the minimum value of the resistor is determined by the current-sinking capability of the driver.

All outputs are designed to sink up to 12 mA, and include equivalent 30- Ω resistors to reduce overshoot and undershoot.

Active bus-hold circuitry is provided to hold unused or floating data inputs at a valid logic level.

The SN54ALVTH162827 is characterized for operation over the full military temperature range of -55°C to 125°C . The SN74ALVTH162827 is characterized for operation from -40°C to 85°C .

FUNCTION TABLE
(each 10-bit section)

INPUTS			OUTPUT
$\overline{OE1}$	$\overline{OE2}$	A	Y
L	L	L	L
L	L	H	H
H	X	X	Z
X	H	X	Z

logic diagram (positive logic)

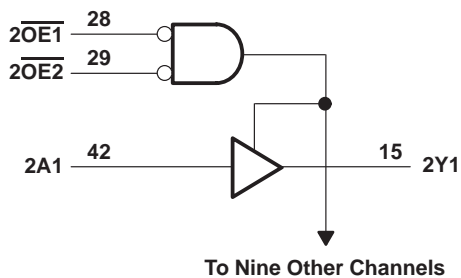
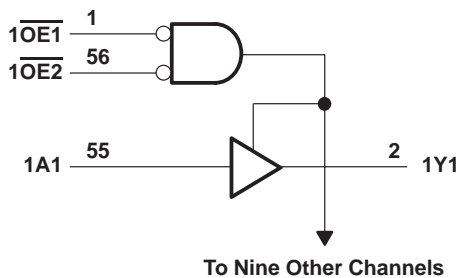

SN54ALVTH162827, SN74ALVTH162827 2.5-V/3.3-V 20-BIT BUFFERS/DRIVERS WITH 3-STATE OUTPUTS

SCES079E – JULY 1996 – REVISED DECEMBER 1998

absolute maximum ratings over operating free-air temperature range (unless otherwise noted)†

Supply voltage range, V_{CC}	–0.5 V to 4.6 V
Input voltage range, V_I (see Note 1)	–0.5 V to 7 V
Voltage range applied to any output in the high-impedance or power-off state, V_O (see Note 1)	–0.5 V to 7 V
Voltage range applied to any output in the high state, V_O (see Note 1)	–0.5 V to 7 V
Output current in the low state, I_{OL} : SN54ALVTH162827	96 mA
SN74ALVTH162827	128 mA
Output current in the high state, I_{OH} : SN54ALVTH162827	–48 mA
SN74ALVTH162827	–64 mA
Input clamp current, I_{IK} ($V_I < 0$)	–50 mA
Output clamp current, I_{OK} ($V_O < 0$)	–50 mA
Package thermal impedance, θ_{JA} (see Note 2): DGG package	81°C/W
DGV package	86°C/W
DL package	74°C/W
Storage temperature range, T_{stg}	–65°C to 150°C

† Stresses beyond those listed under “absolute maximum ratings” may cause permanent damage to the device. These are stress ratings only, and functional operation of the device at these or any other conditions beyond those indicated under “recommended operating conditions” is not implied. Exposure to absolute-maximum-rated conditions for extended periods may affect device reliability.

- NOTES: 1. The input and output negative-voltage ratings may be exceeded if the input and output clamp-current ratings are observed.
2. The package thermal impedance is calculated in accordance with JESD 51.

recommended operating conditions, $V_{CC} = 2.5\text{ V} \pm 0.2\text{ V}$ (see Note 3)

		SN54ALVTH162827			SN74ALVTH162827			UNIT
		MIN	TYP	MAX	MIN	TYP	MAX	
V_{CC}	Supply voltage	2.3		2.7	2.3		2.7	V
V_{IH}	High-level input voltage	1.7			1.7			V
V_{IL}	Low-level input voltage			0.7			0.7	V
V_I	Input voltage	0	V_{CC}	5.5	0	V_{CC}	5.5	V
I_{OH}	High-level output current			–6			–8	mA
I_{OL}	Low-level output current			8			12	mA
$\Delta t/\Delta v$	Input transition rise or fall rate			10			10	ns/V
		Outputs enabled						
$\Delta t/\Delta V_{CC}$	Power-up ramp rate	200			200			$\mu\text{s}/\text{V}$
T_A	Operating free-air temperature	–55		125	–40		85	°C

NOTE 3: All unused control inputs of the device must be held at V_{CC} or GND to ensure proper device operation. Refer to the TI application report, *Implications of Slow or Floating CMOS Inputs*, literature number SCBA004.

SN54ALVTH162827, SN74ALVTH162827
2.5-V/3.3-V 20-BIT BUFFERS/DRIVERS
WITH 3-STATE OUTPUTS

SCES079E – JULY 1996 – REVISED DECEMBER 1998

recommended operating conditions, $V_{CC} = 3.3\text{ V} \pm 0.3\text{ V}$ (see Note 3)

		SN54ALVTH162827			SN74ALVTH162827			UNIT
		MIN	TYP	MAX	MIN	TYP	MAX	
V_{CC}	Supply voltage	3		3.6	3		3.6	V
V_{IH}	High-level input voltage	2			2			V
V_{IL}	Low-level input voltage			0.8			0.8	V
V_I	Input voltage	0	V_{CC}	5.5	0	V_{CC}	5.5	V
I_{OH}	High-level output current			-8			-12	mA
I_{OL}	Low-level output current			8			12	mA
$\Delta t/\Delta v$	Input transition rise or fall rate	Outputs enabled		10			10	ns/V
$\Delta t/\Delta V_{CC}$	Power-up ramp rate	200			200			$\mu\text{s/V}$
T_A	Operating free-air temperature	-55		125	-40		85	$^{\circ}\text{C}$

NOTE 3: All unused control inputs of the device must be held at V_{CC} or GND to ensure proper device operation. Refer to the TI application report, *Implications of Slow or Floating CMOS Inputs*, literature number SCBA004.

SN54ALVTH162827, SN74ALVTH162827
2.5-V/3.3-V 20-BIT BUFFERS/DRIVERS
WITH 3-STATE OUTPUTS

SCES079E – JULY 1996 – REVISED DECEMBER 1998

electrical characteristics over recommended operating free-air temperature range,
 $V_{CC} = 2.5 \text{ V} \pm 0.2 \text{ V}$ (unless otherwise noted)

PARAMETER	TEST CONDITIONS	SN54ALVTH162827		SN74ALVTH162827		UNIT		
		MIN	TYP†	MAX	MIN		TYP†	MAX
V_{IK}	$V_{CC} = 2.3 \text{ V}$, $I_I = -18 \text{ mA}$			-1.2		-1.2	V	
V_{OH}	$V_{CC} = 2.3 \text{ V to } 2.7 \text{ V}$, $I_{OH} = -100 \mu\text{A}$	$V_{CC}-0.2$			$V_{CC}-0.2$		V	
	$V_{CC} = 2.3 \text{ V}$		1.7			1.7		
V_{OL}	$V_{CC} = 2.3 \text{ V to } 2.7 \text{ V}$, $I_{OL} = 100 \mu\text{A}$			0.2		0.2	V	
	$V_{CC} = 2.3 \text{ V}$			0.7				
						0.7		
I_I	Control inputs	$V_{CC} = 2.7 \text{ V}$, $V_I = V_{CC} \text{ or GND}$		± 1		± 1	μA	
		$V_{CC} = 0 \text{ or } 2.7 \text{ V}$, $V_I = 5.5 \text{ V}$		10		10		
	Data inputs	$V_{CC} = 2.7 \text{ V}$		10		10		
			$V_I = 5.5 \text{ V}$		1			1
		$V_I = 0$		-5		-5		
I_{off}	$V_{CC} = 0$, $V_I \text{ or } V_O = 0 \text{ to } 4.5 \text{ V}$					± 100	μA	
I_{BHL}^\ddagger	$V_{CC} = 2.3 \text{ V}$, $V_I = 0.7 \text{ V}$		115		115		μA	
I_{BHH}^\S	$V_{CC} = 2.3 \text{ V}$, $V_I = 1.7 \text{ V}$		-10		-10		μA	
I_{BHLO}^\P	$V_{CC} = 2.7 \text{ V}$, $V_I = 0 \text{ to } V_{CC}$	300			300		μA	
$I_{BHHO}^\#$	$V_{CC} = 2.7 \text{ V}$, $V_I = 0 \text{ to } V_{CC}$	-300			-300		μA	
I_{EX}^\parallel	$V_{CC} = 2.3 \text{ V}$, $V_O = 5.5 \text{ V}$			125		125	μA	
$I_{OZ(PU/PD)}^\star$	$V_{CC} \leq 1.2 \text{ V}$, $V_O = 0.5 \text{ V to } V_{CC}$, $V_I = \text{GND or } V_{CC}$, $\overline{OE} = \text{don't care}$			± 100		± 100	μA	
I_{OZH}	$V_{CC} = 2.7 \text{ V}$			5		5	μA	
I_{OZL}	$V_{CC} = 2.7 \text{ V}$			-5		-5	μA	
I_{CC}	$V_{CC} = 2.7 \text{ V}$, $I_O = 0$, $V_I = V_{CC} \text{ or GND}$	Outputs high	0.04	0.1	0.04	0.1	mA	
		Outputs low		2.3	5	2.3		5
		Outputs disabled	0.04	0.1	0.04	0.1		
C_i	$V_{CC} = 2.5 \text{ V}$, $V_I = 2.5 \text{ V or } 0$			3.5		3.5	pF	
C_o	$V_{CC} = 2.5 \text{ V}$, $V_O = 2.5 \text{ V or } 0$			6		6	pF	

† All typical values are at $V_{CC} = 2.5 \text{ V}$, $T_A = 25^\circ\text{C}$.

‡ The bus-hold circuit can sink at least the minimum low sustaining current at V_{IL} max. I_{BHL} should be measured after lowering V_{IN} to GND and then raising it to V_{IL} max.

§ The bus-hold circuit can source at least the minimum high sustaining current at V_{IH} min. I_{BHH} should be measured after raising V_{IN} to V_{CC} and then lowering it to V_{IH} min.

¶ An external driver must source at least I_{BHLO} to switch this node from low to high.

An external driver must sink at least I_{BHHO} to switch this node from high to low.

|| Current into an output in the high state when $V_O > V_{CC}$

☆ High-impedance state during power up or power down

SN54ALVTH162827, SN74ALVTH162827

2.5-V/3.3-V 20-BIT BUFFERS/DRIVERS

WITH 3-STATE OUTPUTS

SCES079E – JULY 1996 – REVISED DECEMBER 1998

electrical characteristics over recommended operating free-air temperature range,
 $V_{CC} = 3.3 \text{ V} \pm 0.3 \text{ V}$ (unless otherwise noted)

PARAMETER	TEST CONDITIONS		SN54ALVTH162827			SN74ALVTH162827			UNIT	
			MIN	TYP†	MAX	MIN	TYP†	MAX		
V_{IK}	$V_{CC} = 3 \text{ V}$, $I_I = -18 \text{ mA}$		-1.2			-1.2			V	
V_{OH}	$V_{CC} = 3 \text{ V to } 3.6 \text{ V}$, $I_{OH} = -100 \mu\text{A}$		$V_{CC}-0.2$			$V_{CC}-0.2$			V	
	$V_{CC} = 3 \text{ V}$	$I_{OH} = -8 \text{ mA}$	2			2				
V_{OL}	$V_{CC} = 3 \text{ V to } 3.6 \text{ V}$, $I_{OL} = 100 \mu\text{A}$		0.2			0.2			V	
	$V_{CC} = 3 \text{ V}$	$I_{OL} = 8 \text{ mA}$	0.8							
		$I_{OL} = 12 \text{ mA}$				0.8				
I_I	Control inputs	$V_{CC} = 3.6 \text{ V}$, $V_I = V_{CC} \text{ or GND}$	± 1			± 1			μA	
		$V_{CC} = 0 \text{ or } 3.6 \text{ V}$, $V_I = 5.5 \text{ V}$	10			10				
	Data inputs	$V_{CC} = 3.6 \text{ V}$	$V_I = 5.5 \text{ V}$	10			10			
			$V_I = V_{CC}$	1			1			
		$V_I = 0$	-5			-5				
I_{off}	$V_{CC} = 0$, $V_I \text{ or } V_O = 0 \text{ to } 4.5 \text{ V}$					± 100			μA	
I_{BHL}^\ddagger	$V_{CC} = 3 \text{ V}$, $V_I = 0.8 \text{ V}$		75			75			μA	
I_{BHH}^\S	$V_{CC} = 3 \text{ V}$, $V_I = 2 \text{ V}$		-75			-75			μA	
I_{BHLO}^\P	$V_{CC} = 3.6 \text{ V}$, $V_I = 0 \text{ to } V_{CC}$		500			500			μA	
$I_{BHHO}^\#$	$V_{CC} = 3.6 \text{ V}$, $V_I = 0 \text{ to } V_{CC}$		-500			-500			μA	
I_{EX}^\parallel	$V_{CC} = 3 \text{ V}$, $V_O = 5.5 \text{ V}$		125			125			μA	
$I_{OZ(PU/PD)}^\star$	$V_{CC} \leq 1.2 \text{ V}$, $V_O = 0.5 \text{ V to } V_{CC}$, $V_I = \text{GND or } V_{CC}$, $\overline{OE} = \text{don't care}$		± 100			± 100			μA	
I_{OZH}	$V_{CC} = 3.6 \text{ V}$	$V_O = 3 \text{ V}$, $V_I = 0.8 \text{ V or } 2 \text{ V}$	5			5			μA	
I_{OZL}	$V_{CC} = 3.6 \text{ V}$	$V_O = 0.5 \text{ V}$, $V_I = 0.8 \text{ V or } 2 \text{ V}$	-5			-5			μA	
I_{CC}	$V_{CC} = 3.6 \text{ V}$, $I_O = 0$, $V_I = V_{CC} \text{ or GND}$		Outputs high		0.07	0.1	0.07	0.1	mA	
			Outputs low		3.2	5.5	3.2	5.5		
			Outputs disabled		0.07	0.1	0.07	0.1		
ΔI_{CC}^\square	$V_{CC} = 3 \text{ V to } 3.6 \text{ V}$, One input at $V_{CC} - 0.6 \text{ V}$, Other inputs at $V_{CC} \text{ or GND}$		0.4			0.4			mA	
C_i	$V_{CC} = 3.3 \text{ V}$, $V_I = 3.3 \text{ V or } 0$		3.5			3.5			pF	
C_o	$V_{CC} = 3.3 \text{ V}$, $V_O = 3.3 \text{ V or } 0$		6			6			pF	

† All typical values are at $V_{CC} = 3.3 \text{ V}$, $T_A = 25^\circ\text{C}$.

‡ The bus-hold circuit can sink at least the minimum low sustaining current at $V_{IL} \text{ max}$. I_{BHL} should be measured after lowering V_{IN} to GND and then raising it to $V_{IL} \text{ max}$.

§ The bus-hold circuit can source at least the minimum high sustaining current at $V_{IH} \text{ min}$. I_{BHH} should be measured after raising V_{IN} to V_{CC} and then lowering it to $V_{IH} \text{ min}$.

¶ An external driver must source at least I_{BHLO} to switch this node from low to high.

An external driver must sink at least I_{BHHO} to switch this node from high to low.

|| Current into an output in the high state when $V_O > V_{CC}$

* High-impedance state during power up or power down

□ This is the increase in supply current for each input that is at the specified TTL voltage level rather than V_{CC} or GND.

SN54ALVTH162827, SN74ALVTH162827
2.5-V/3.3-V 20-BIT BUFFERS/DRIVERS
WITH 3-STATE OUTPUTS

SCES079E – JULY 1996 – REVISED DECEMBER 1998

switching characteristics over recommended operating free-air temperature range, $C_L = 30\text{ pF}$, $V_{CC} = 2.5\text{ V} \pm 0.2\text{ V}$ (unless otherwise noted) (see Figure 1)

PARAMETER	FROM (INPUT)	TO (OUTPUT)	SN54ALVTH162827		SN74ALVTH162827		UNIT
			MIN	MAX	MIN	MAX	
t_{PLH}	A	Y	1.7	4.1	1.7	4.1	ns
t_{PHL}			1.6	4	1.6	4	
t_{PZH}	\overline{OE}	Y	2.1	4.8	2.1	4.8	ns
t_{PZL}			1.9	4.8	1.9	4.8	
t_{PHZ}	\overline{OE}	Y	2.4	6	2.4	6	ns
t_{PLZ}			1.7	5	1.7	5	

switching characteristics over recommended operating free-air temperature range, $C_L = 50\text{ pF}$, $V_{CC} = 3.3\text{ V} \pm 0.3\text{ V}$ (unless otherwise noted) (see Figure 2)

PARAMETER	FROM (INPUT)	TO (OUTPUT)	SN54ALVTH162827		SN74ALVTH162827		UNIT
			MIN	MAX	MIN	MAX	
t_{PLH}	A	Y	1	3.9	1	3.9	ns
t_{PHL}			1.5	3.7	1.5	3.7	
t_{PZH}	\overline{OE}	Y	1	5.6	1	5.6	ns
t_{PZL}			1.7	4.1	1.7	4.1	
t_{PHZ}	\overline{OE}	Y	3.6	6.3	3.6	6.3	ns
t_{PLZ}			1.7	5.1	1.7	5.1	

PRODUCT PREVIEW information concerns products in the formative or design phase of development. Characteristic data and other specifications are design goals. Texas Instruments reserves the right to change or discontinue these products without notice.



SN54ALVTH162827, SN74ALVTH162827
2.5-V/3.3-V 20-BIT BUFFERS/DRIVERS
WITH 3-STATE OUTPUTS

SCES079E – JULY 1996 – REVISED DECEMBER 1998

PARAMETER MEASUREMENT INFORMATION

$V_{CC} = 2.5\text{ V} \pm 0.2\text{ V}$

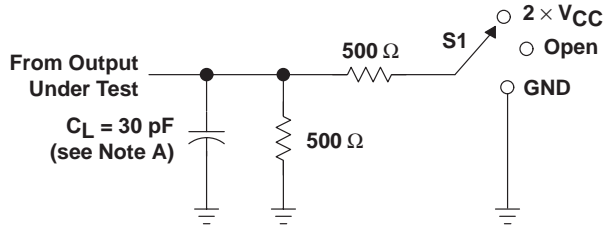

LOAD CIRCUIT

TEST	S1
t_{PLH}/t_{PHL}	Open
t_{PLZ}/t_{PZL}	2 $\times V_{CC}$
t_{PHZ}/t_{PZH}	GND

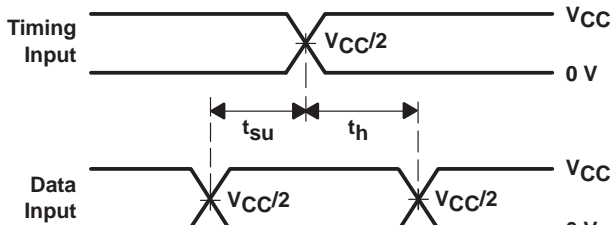

**VOLTAGE WAVEFORMS
 SETUP AND HOLD TIMES**

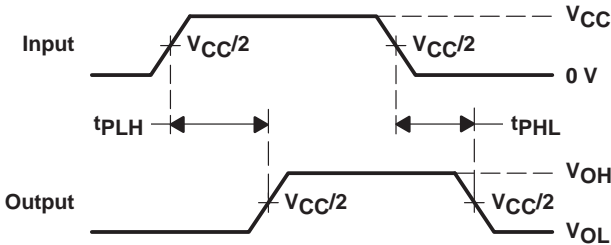

**VOLTAGE WAVEFORMS
 PROPAGATION DELAY TIMES**

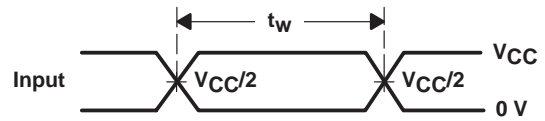

**VOLTAGE WAVEFORMS
 PULSE DURATION**

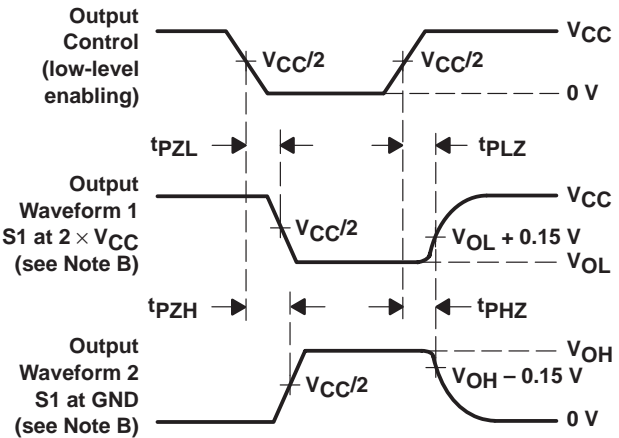

**VOLTAGE WAVEFORMS
 ENABLE AND DISABLE TIMES**

- NOTES: A. C_L includes probe and jig capacitance.
 B. Waveform 1 is for an output with internal conditions such that the output is low except when disabled by the output control. Waveform 2 is for an output with internal conditions such that the output is high except when disabled by the output control.
 C. All input pulses are supplied by generators having the following characteristics: PRR $\leq 10\text{ MHz}$, $Z_O = 50\ \Omega$, $t_r \leq 2\text{ ns}$, $t_f \leq 2\text{ ns}$.
 D. The outputs are measured one at a time with one transition per measurement.

Figure 1. Load Circuit and Voltage Waveforms

PARAMETER MEASUREMENT INFORMATION

$V_{CC} = 3.3\text{ V} \pm 0.3\text{ V}$

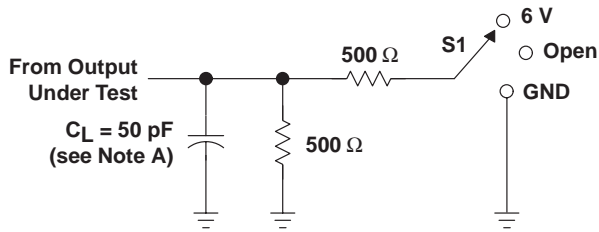

LOAD CIRCUIT

TEST	S1
t_{PLH}/t_{PHL}	Open
t_{PLZ}/t_{PZL}	6 V
t_{PHZ}/t_{PZH}	GND

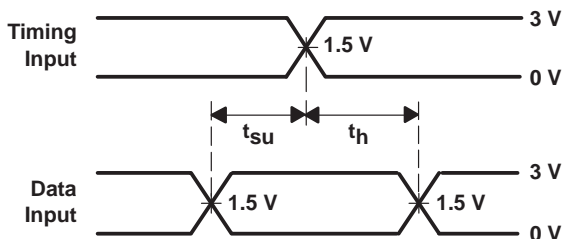

VOLTAGE WAVEFORMS
 SETUP AND HOLD TIMES

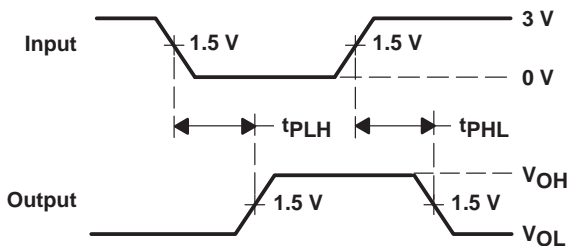

VOLTAGE WAVEFORMS
 PROPAGATION DELAY TIMES
 INVERTING AND NONINVERTING OUTPUTS

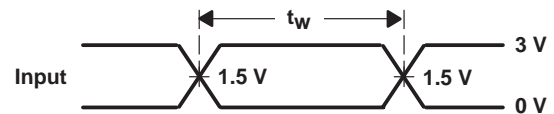

VOLTAGE WAVEFORMS
 PULSE DURATION

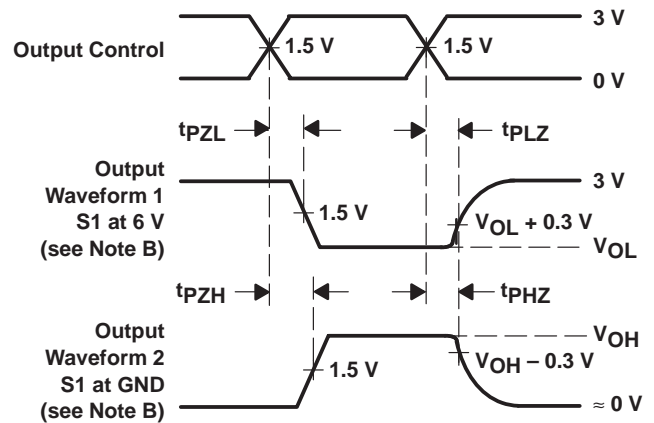

VOLTAGE WAVEFORMS
 ENABLE AND DISABLE TIMES
 LOW- AND HIGH-LEVEL ENABLING

- NOTES: A. C_L includes probe and jig capacitance.
 B. Waveform 1 is for an output with internal conditions such that the output is low except when disabled by the output control. Waveform 2 is for an output with internal conditions such that the output is high except when disabled by the output control.
 C. All input pulses are supplied by generators having the following characteristics: $PRR \leq 10\text{ MHz}$, $Z_O = 50\ \Omega$, $t_r \leq 2.5\text{ ns}$, $t_f \leq 2.5\text{ ns}$.
 D. The outputs are measured one at a time with one transition per measurement.

Figure 2. Load Circuit and Voltage Waveforms

PACKAGING INFORMATION

Orderable Device	Status ⁽¹⁾	Package Type	Package Drawing	Pins	Package Qty	Eco Plan ⁽²⁾	Lead/Ball Finish	MSL Peak Temp ⁽³⁾
74ALVTH162827DLG4	ACTIVE	SSOP	DL	56	20	Green (RoHS & no Sb/Br)	CU NIPDAU	Level-1-260C-UNLIM
74ALVTH162827GRE4	ACTIVE	TSSOP	DGG	56	2000	Green (RoHS & no Sb/Br)	CU NIPDAU	Level-1-260C-UNLIM
74ALVTH162827LRG4	ACTIVE	SSOP	DL	56	1000	Green (RoHS & no Sb/Br)	CU NIPDAU	Level-1-260C-UNLIM
74ALVTH162827VRE4	ACTIVE	TVSOP	DGV	56	2000	Green (RoHS & no Sb/Br)	CU NIPDAU	Level-1-260C-UNLIM
SN74ALVTH162827DL	ACTIVE	SSOP	DL	56	20	Green (RoHS & no Sb/Br)	CU NIPDAU	Level-1-260C-UNLIM
SN74ALVTH162827GR	ACTIVE	TSSOP	DGG	56	2000	Green (RoHS & no Sb/Br)	CU NIPDAU	Level-1-260C-UNLIM
SN74ALVTH162827LR	ACTIVE	SSOP	DL	56	1000	Green (RoHS & no Sb/Br)	CU NIPDAU	Level-1-260C-UNLIM
SN74ALVTH162827VR	ACTIVE	TVSOP	DGV	56	2000	Green (RoHS & no Sb/Br)	CU NIPDAU	Level-1-260C-UNLIM

⁽¹⁾ The marketing status values are defined as follows:

ACTIVE: Product device recommended for new designs.

LIFEBUY: TI has announced that the device will be discontinued, and a lifetime-buy period is in effect.

NRND: Not recommended for new designs. Device is in production to support existing customers, but TI does not recommend using this part in a new design.

PREVIEW: Device has been announced but is not in production. Samples may or may not be available.

OBSOLETE: TI has discontinued the production of the device.

⁽²⁾ Eco Plan - The planned eco-friendly classification: Pb-Free (RoHS), Pb-Free (RoHS Exempt), or Green (RoHS & no Sb/Br) - please check <http://www.ti.com/productcontent> for the latest availability information and additional product content details.

TBD: The Pb-Free/Green conversion plan has not been defined.

Pb-Free (RoHS): TI's terms "Lead-Free" or "Pb-Free" mean semiconductor products that are compatible with the current RoHS requirements for all 6 substances, including the requirement that lead not exceed 0.1% by weight in homogeneous materials. Where designed to be soldered at high temperatures, TI Pb-Free products are suitable for use in specified lead-free processes.

Pb-Free (RoHS Exempt): This component has a RoHS exemption for either 1) lead-based flip-chip solder bumps used between the die and package, or 2) lead-based die adhesive used between the die and leadframe. The component is otherwise considered Pb-Free (RoHS compatible) as defined above.

Green (RoHS & no Sb/Br): TI defines "Green" to mean Pb-Free (RoHS compatible), and free of Bromine (Br) and Antimony (Sb) based flame retardants (Br or Sb do not exceed 0.1% by weight in homogeneous material)

⁽³⁾ MSL, Peak Temp. -- The Moisture Sensitivity Level rating according to the JEDEC industry standard classifications, and peak solder temperature.

Important Information and Disclaimer:The information provided on this page represents TI's knowledge and belief as of the date that it is provided. TI bases its knowledge and belief on information provided by third parties, and makes no representation or warranty as to the accuracy of such information. Efforts are underway to better integrate information from third parties. TI has taken and continues to take reasonable steps to provide representative and accurate information but may not have conducted destructive testing or chemical analysis on incoming materials and chemicals. TI and TI suppliers consider certain information to be proprietary, and thus CAS numbers and other limited information may not be available for release.

In no event shall TI's liability arising out of such information exceed the total purchase price of the TI part(s) at issue in this document sold by TI to Customer on an annual basis.

DGV (R-PDSO-G**)

PLASTIC SMALL-OUTLINE

24 PINS SHOWN



- NOTES: A. All linear dimensions are in millimeters.
 B. This drawing is subject to change without notice.
 C. Body dimensions do not include mold flash or protrusion, not to exceed 0,15 per side.
 D. Falls within JEDEC: 24/48 Pins – MO-153
 14/16/20/56 Pins – MO-194

DL (R-PDSO-G**)

PLASTIC SMALL-OUTLINE PACKAGE

48 PINS SHOWN

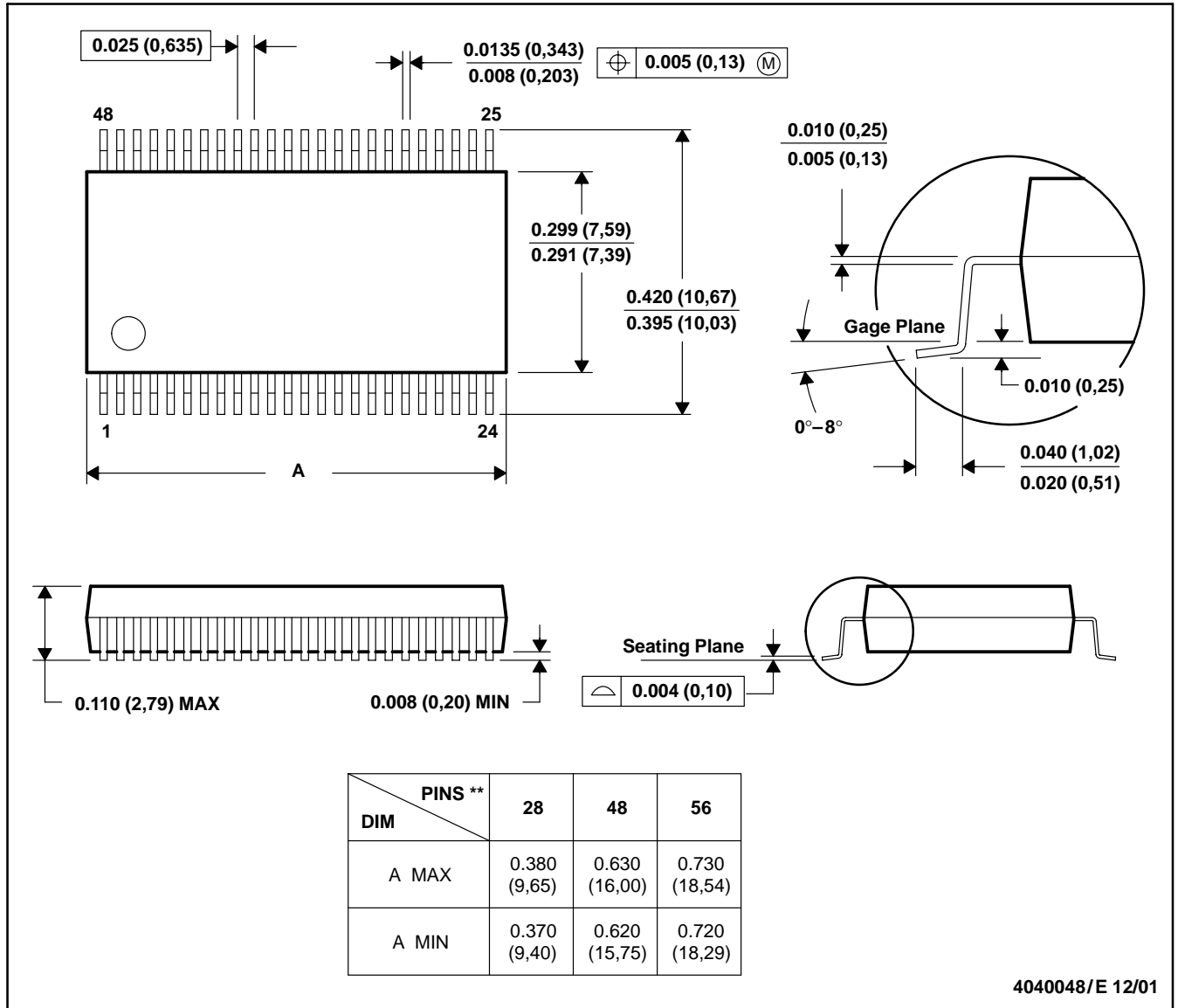

- NOTES: A. All linear dimensions are in inches (millimeters).
 B. This drawing is subject to change without notice.
 C. Body dimensions do not include mold flash or protrusion not to exceed 0.006 (0,15).
 D. Falls within JEDEC MO-118

DGG (R-PDSO-G**)

PLASTIC SMALL-OUTLINE PACKAGE

48 PINS SHOWN



- NOTES: A. All linear dimensions are in millimeters.
 B. This drawing is subject to change without notice.
 C. Body dimensions do not include mold protrusion not to exceed 0,15.
 D. Falls within JEDEC MO-153

IMPORTANT NOTICE

Texas Instruments Incorporated and its subsidiaries (TI) reserve the right to make corrections, modifications, enhancements, improvements, and other changes to its products and services at any time and to discontinue any product or service without notice. Customers should obtain the latest relevant information before placing orders and should verify that such information is current and complete. All products are sold subject to TI's terms and conditions of sale supplied at the time of order acknowledgment.

TI warrants performance of its hardware products to the specifications applicable at the time of sale in accordance with TI's standard warranty. Testing and other quality control techniques are used to the extent TI deems necessary to support this warranty. Except where mandated by government requirements, testing of all parameters of each product is not necessarily performed.

TI assumes no liability for applications assistance or customer product design. Customers are responsible for their products and applications using TI components. To minimize the risks associated with customer products and applications, customers should provide adequate design and operating safeguards.

TI does not warrant or represent that any license, either express or implied, is granted under any TI patent right, copyright, mask work right, or other TI intellectual property right relating to any combination, machine, or process in which TI products or services are used. Information published by TI regarding third-party products or services does not constitute a license from TI to use such products or services or a warranty or endorsement thereof. Use of such information may require a license from a third party under the patents or other intellectual property of the third party, or a license from TI under the patents or other intellectual property of TI.

Reproduction of information in TI data books or data sheets is permissible only if reproduction is without alteration and is accompanied by all associated warranties, conditions, limitations, and notices. Reproduction of this information with alteration is an unfair and deceptive business practice. TI is not responsible or liable for such altered documentation.

Resale of TI products or services with statements different from or beyond the parameters stated by TI for that product or service voids all express and any implied warranties for the associated TI product or service and is an unfair and deceptive business practice. TI is not responsible or liable for any such statements.

Following are URLs where you can obtain information on other Texas Instruments products and application solutions:

Products		Applications	
Amplifiers	amplifier.ti.com	Audio	www.ti.com/audio
Data Converters	dataconverter.ti.com	Automotive	www.ti.com/automotive
DSP	dsp.ti.com	Broadband	www.ti.com/broadband
Interface	interface.ti.com	Digital Control	www.ti.com/digitalcontrol
Logic	logic.ti.com	Military	www.ti.com/military
Power Mgmt	power.ti.com	Optical Networking	www.ti.com/opticalnetwork
Microcontrollers	microcontroller.ti.com	Security	www.ti.com/security
Low Power Wireless	www.ti.com/lpw	Telephony	www.ti.com/telephony
		Video & Imaging	www.ti.com/video
		Wireless	www.ti.com/wireless

Mailing Address: Texas Instruments
Post Office Box 655303 Dallas, Texas 75265