

SN54ALVTH16245, SN74ALVTH16245 2.5-V/3.3-V 16-BIT BUS TRANSCEIVERS WITH 3-STATE OUTPUTS

SCES066G – JUNE 1996 – REVISED APRIL 2002

- **State-of-the-Art Advanced BiCMOS Technology (ABT) Widebus™ Design for 2.5-V and 3.3-V Operation and Low Static-Power Dissipation**
- **Support Mixed-Mode Signal Operation (5-V Input and Output Voltages With 2.3-V to 3.6-V V_{CC})**
- **Typical V_{OLP} (Output Ground Bounce) <0.8 V at $V_{CC} = 3.3$ V, $T_A = 25^\circ\text{C}$**
- **High Drive ($-32/64$ mA at 3.3-V V_{CC})**
- **I_{off} and Power-Up 3-State Support Hot Insertion**
- **Use Bus Hold on Data Inputs in Place of External Pullup/Pulldown Resistors to Prevent the Bus From Floating**
- **Flow-Through Architecture Facilitates Printed Circuit Board Layout**
- **Distributed V_{CC} and GND Pins Minimize High-Speed Switching Noise**
- **Latch-Up Performance Exceeds 100 mA Per JESD 78, Class II**

description

The 'ALVTH16245 devices are 16-bit (dual-octal) noninverting 3-state transceivers designed for 2.5-V or 3.3-V V_{CC} operation, but with the capability to provide a TTL interface to a 5-V system environment.

These devices can be used as two 8-bit transceivers or one 16-bit transceiver. They allow data transmission from the A bus to the B bus or from the B bus to the A bus, depending on the logic level at the direction-control (DIR) input. The output-enable (\overline{OE}) input can be used to disable the device so that the buses are effectively isolated.

These devices are fully specified for hot-insertion applications using I_{off} and power-up 3-state. The I_{off} circuitry disables the outputs, preventing damaging current backflow through the device when it is powered down. The power-up 3-state circuitry places the outputs in the high-impedance state during power up and power down, which prevents driver conflict.

Active bus-hold circuitry is provided to hold unused or floating data inputs at a valid logic level. Use of pullup or pulldown resistors with the bus-hold circuitry is not recommended.

When V_{CC} is between 0 and 1.2 V, the devices are in the high-impedance state during power up or power down. However, to ensure the high-impedance state above 1.2 V, \overline{OE} should be tied to V_{CC} through a pullup resistor; the minimum value of the resistor is determined by the current-sinking capability of the driver.

SN54ALVTH16245 . . . WD PACKAGE
SN74ALVTH16245 . . . DGG, DGV, OR DL PACKAGE
(TOP VIEW)

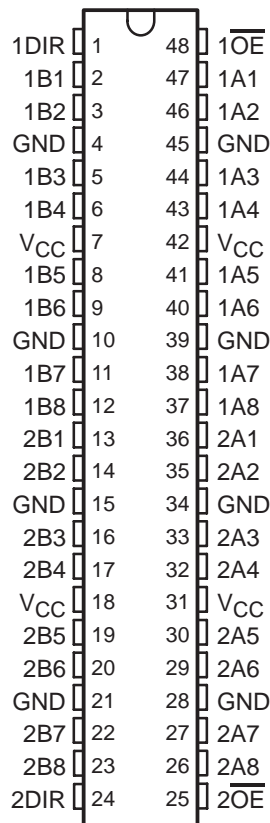

Please be aware that an important notice concerning availability, standard warranty, and use in critical applications of Texas Instruments semiconductor products and disclaimers thereto appears at the end of this data sheet.

Widebus is a trademark of Texas Instruments.

UNLESS OTHERWISE NOTED this document contains PRODUCTION DATA information current as of publication date. Products conform to specifications per the terms of Texas Instruments standard warranty. Production processing does not necessarily include testing of all parameters.

 **TEXAS
INSTRUMENTS**

POST OFFICE BOX 655303 • DALLAS, TEXAS 75265

Copyright © 2002, Texas Instruments Incorporated

SN54ALVTH16245, SN74ALVTH16245 2.5-V/3.3-V 16-BIT BUS TRANSCEIVERS WITH 3-STATE OUTPUTS

SCES066G – JUNE 1996 – REVISED APRIL 2002

logic diagram (positive logic)

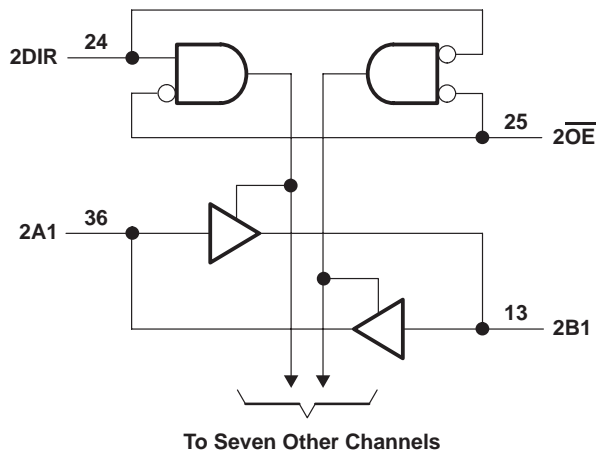
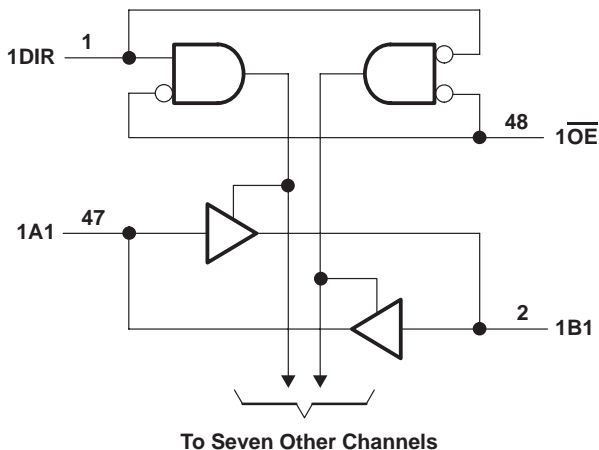

Pin numbers shown are for the DGG, DGV, DL, and WD packages.

absolute maximum ratings over operating free-air temperature range (unless otherwise noted)†

Supply voltage range, V_{CC}	-0.5 V to 4.6 V
Input voltage range, V_I (see Note 1)	-0.5 V to 7 V
Voltage range applied to any output in the high or power-off state, V_O (see Note 1)	-0.5 V to 7 V
Output current in the low state, I_O : SN54ALVTH16245	96 mA
SN74ALVTH16245	128 mA
Output current in the high state, I_O : SN54ALVTH16245	-48 mA
SN74ALVTH16245	-64 mA
Input clamp current, I_{IK} ($V_I < 0$)	-50 mA
Output clamp current, I_{OK} ($V_O < 0$)	-50 mA
Package thermal impedance, θ_{JA} (see Note 2): DGG package	70°C/W
DGV package	58°C/W
DL package	63°C/W
GQL package	42°C/W
Storage temperature range, T_{Stg}	-65°C to 150°C

† Stresses beyond those listed under "absolute maximum ratings" may cause permanent damage to the device. These are stress ratings only, and functional operation of the device at these or any other conditions beyond those indicated under "recommended operating conditions" is not implied. Exposure to absolute-maximum-rated conditions for extended periods may affect device reliability.

- NOTES: 1. The input and output negative-voltage ratings may be exceeded if the input and output clamp-current ratings are observed.
2. The package thermal impedance is calculated in accordance with JESD 51-7.

SN54ALVTH16245, SN74ALVTH16245 2.5-V/3.3-V 16-BIT BUS TRANSCEIVERS WITH 3-STATE OUTPUTS

SCES066G – JUNE 1996 – REVISED APRIL 2002

recommended operating conditions, $V_{CC} = 2.5\text{ V} \pm 0.2\text{ V}$ (see Note 3)

		SN54ALVTH16245			SN74ALVTH16245			UNIT
		MIN	TYP	MAX	MIN	TYP	MAX	
V_{CC}	Supply voltage	2.3		2.7	2.3		2.7	V
V_{IH}	High-level input voltage	1.7			1.7			V
V_{IL}	Low-level input voltage			0.7			0.7	V
V_I	Input voltage	0	V_{CC}	5.5	0	V_{CC}	5.5	V
I_{OH}	High-level output current			-6			-8	mA
I_{OL}	Low-level output current			6			8	mA
	Low-level output current; current duty cycle $\leq 50\%$; $f \geq 1\text{ kHz}$			18			24	
$\Delta t/\Delta v$	Input transition rise or fall rate	Outputs enabled		10			10	ns/V
$\Delta t/\Delta V_{CC}$	Power-up ramp rate	200			200			$\mu\text{s/V}$
T_A	Operating free-air temperature	-55		125	-40		85	$^{\circ}\text{C}$

NOTE 3: All unused control inputs of the device must be held at V_{CC} or GND to ensure proper device operation. Refer to the TI application report, *Implications of Slow or Floating CMOS Inputs*, literature number SCBA004.

recommended operating conditions, $V_{CC} = 3.3\text{ V} \pm 0.3\text{ V}$ (see Note 3)

		SN54ALVTH16245			SN74ALVTH16245			UNIT
		MIN	TYP	MAX	MIN	TYP	MAX	
V_{CC}	Supply voltage	3		3.6	3		3.6	V
V_{IH}	High-level input voltage	2			2			V
V_{IL}	Low-level input voltage			0.8			0.8	V
V_I	Input voltage	0	V_{CC}	5.5	0	V_{CC}	5.5	V
I_{OH}	High-level output current			-24			-32	mA
I_{OL}	Low-level output current			24			32	mA
	Low-level output current; current duty cycle $\leq 50\%$; $f \geq 1\text{ kHz}$			48			64	
$\Delta t/\Delta v$	Input transition rise or fall rate	Outputs enabled		10			10	ns/V
$\Delta t/\Delta V_{CC}$	Power-up ramp rate	200			200			$\mu\text{s/V}$
T_A	Operating free-air temperature	-55		125	-40		85	$^{\circ}\text{C}$

NOTE 3: All unused control inputs of the device must be held at V_{CC} or GND to ensure proper device operation. Refer to the TI application report, *Implications of Slow or Floating CMOS Inputs*, literature number SCBA004.

SN54ALVTH16245, SN74ALVTH16245 2.5-V/3.3-V 16-BIT BUS TRANSCEIVERS WITH 3-STATE OUTPUTS

SCES066G – JUNE 1996 – REVISED APRIL 2002

**electrical characteristics over recommended operating free-air temperature range,
V_{CC} = 2.5 V ± 0.2 V (unless otherwise noted)**

PARAMETER		TEST CONDITIONS		SN54ALVTH16245		SN74ALVTH16245		UNIT		
				MIN	TYP†	MAX	MIN		TYP†	MAX
V _{IK}		V _{CC} = 2.3 V, I _I = -18 mA		-1.2		-1.2		V		
V _{OH}		V _{CC} = 2.3 V to 2.7 V, I _{OH} = -100 μA		V _{CC} -0.2		V _{CC} -0.2		V		
		V _{CC} = 2.3 V		1.8		1.8				
V _{OL}		V _{CC} = 2.3 V to 2.7 V, I _{OL} = 100 μA		0.2		0.2		V		
		V _{CC} = 2.3 V		I _{OL} = 6 mA		0.4				
				I _{OL} = 8 mA		0.4				
				I _{OL} = 18 mA		0.5				
				I _{OL} = 24 mA		0.5				
I _I		V _{CC} = 2.7 V, V _I = V _{CC} or GND		±1		±1		μA		
		Control inputs		V _{CC} = 0 or 2.7 V, V _I = 5.5 V		10			10	
		A or B ports		V _{CC} = 2.7 V, V _I = 5.5 V		20			20	
				V _{CC} = 2.7 V, V _I = V _{CC}		1			1	
		V _{CC} = 2.7 V, V _I = 0		-5		-5				
I _{off}		V _{CC} = 0, V _I or V _O = 0 to 4.5 V				±100		μA		
I _{BHL} ‡		V _{CC} = 2.3 V, V _I = 0.7 V		115		115		μA		
I _{BHH} §		V _{CC} = 2.3 V, V _I = 1.7 V		-10		-10		μA		
I _{BHLO} ¶		V _{CC} = 2.7 V, V _I = 0 to V _{CC}		300		300		μA		
I _{BHHO} #		V _{CC} = 2.7 V, V _I = 0 to V _{CC}		-300		-300		μA		
I _{EX}		V _{CC} = 2.3 V, V _O = 5.5 V		125		125		μA		
I _{OZ(PU/PD)} *		V _{CC} ≤ 1.2 V, V _O = 0.5 V to V _{CC} , V _I = GND or V _{CC} , OE = don't care		±100		±100		μA		
I _{CC}		V _{CC} = 2.7 V, I _O = 0, V _I = V _{CC} or GND		Outputs high		0.04 0.1		mA		
				Outputs low		2.3 4.5				
				Outputs disabled		0.04 0.1				
C _i		V _{CC} = 2.5 V, V _I = 2.5 V or 0		3.5		3.5		pF		
C _{io}		V _{CC} = 2.5 V, V _O = 2.5 V or 0		8		8		pF		

† All typical values are at V_{CC} = 2.5 V, T_A = 25°C.

‡ The bus-hold circuit can sink at least the minimum low sustaining current at V_{IL} max. I_{BHL} should be measured after lowering V_{IN} to GND and then raising it to V_{IL} max.

§ The bus-hold circuit can source at least the minimum high sustaining current at V_{IH} min. I_{BHH} should be measured after raising V_{IN} to V_{CC} and then lowering it to V_{IH} min.

¶ An external driver must source at least I_{BHLO} to switch this node from low to high.

An external driver must sink at least I_{BHHO} to switch this node from high to low.

|| Current into an output in the high state when V_O > V_{CC}

* High-impedance state during power up or power down

PRODUCT PREVIEW information concerns products in the formative or design phase of development. Characteristic data and other specifications are design goals. Texas Instruments reserves the right to change or discontinue these products without notice.



POST OFFICE BOX 655303 • DALLAS, TEXAS 75265

SN54ALVTH16245, SN74ALVTH16245 2.5-V/3.3-V 16-BIT BUS TRANSCEIVERS WITH 3-STATE OUTPUTS

SCES066G – JUNE 1996 – REVISED APRIL 2002

electrical characteristics over recommended operating free-air temperature range,
V_{CC} = 3.3 V ± 0.3 V (unless otherwise noted)

PARAMETER		TEST CONDITIONS		SN54ALVTH16245		SN74ALVTH16245		UNIT
				MIN	TYP†	MAX	MIN	
V _{IK}		V _{CC} = 3 V, I _I = -18 mA		-1.2		-1.2		V
V _{OH}		V _{CC} = 3 V to 3.6 V, I _{OH} = -100 μA		V _{CC} -0.2		V _{CC} -0.2		V
		V _{CC} = 3 V		2		2		
V _{OL}		V _{CC} = 3 V to 3.6 V, I _{OL} = 100 μA		0.2		0.2		V
		V _{CC} = 3 V		I _{OL} = 16 mA		0.4		
				I _{OL} = 24 mA		0.5		
				I _{OL} = 32 mA		0.5		
				I _{OL} = 48 mA		0.55		
I _{OL} = 64 mA		0.55						
I _I		V _{CC} = 3.6 V, V _I = V _{CC} or GND		±1		±1		μA
		Control inputs		V _{CC} = 0 or 3.6 V, V _I = 5.5 V		10		
		A or B ports		V _{CC} = 3.6 V, V _I = 5.5 V		20		
				V _{CC} = 3.6 V, V _I = V _{CC}		1		
		V _{CC} = 3.6 V, V _I = 0		-5		-5		
I _{off}		V _{CC} = 0, V _I or V _O = 0 to 4.5 V				±100		μA
I _{BHL} ‡		V _{CC} = 3 V, V _I = 0.8 V		75		75		μA
I _{BHH} §		V _{CC} = 3 V, V _I = 2 V		-75		-75		μA
I _{BHLO} ¶		V _{CC} = 3.6 V, V _I = 0 to V _{CC}		500		500		μA
I _{BHHO} #		V _{CC} = 3.6 V, V _I = 0 to V _{CC}		-500		-500		μA
I _{EX}		V _{CC} = 3 V, V _O = 5.5 V		125		125		μA
I _{OZ} (PU/PD)*		V _{CC} ≤ 1.2 V, V _O = 0.5 V to V _{CC} , V _I = GND or V _{CC} , OE = don't care		±100		±100		μA
I _{CC}		V _{CC} = 3.6 V, I _O = 0, V _I = V _{CC} or GND		Outputs high		0.07 0.1		mA
				Outputs low		3.2 5		
				Outputs disabled		0.07 0.1		
ΔI _{CC} □		V _{CC} = 3 V to 3.6 V, One input at V _{CC} - 0.6 V, Other inputs at V _{CC} or GND		0.2		0.2		mA
C _i		V _{CC} = 3.3 V, V _I = 3.3 V or 0		3.5		3.5		pF
C _{io}		V _{CC} = 3.3 V, V _O = 3.3 V or 0		8		8		pF

† All typical values are at V_{CC} = 3.3 V, T_A = 25°C.

‡ The bus-hold circuit can sink at least the minimum low sustaining current at V_{IL} max. I_{BHL} should be measured after lowering V_{IN} to GND and then raising it to V_{IL} max.

§ The bus-hold circuit can source at least the minimum high sustaining current at V_{IH} min. I_{BHH} should be measured after raising V_{IN} to V_{CC} and then lowering it to V_{IH} min.

¶ An external driver must source at least I_{BHLO} to switch this node from low to high.

An external driver must sink at least I_{BHHO} to switch this node from high to low.

|| Current into an output in the high state when V_O > V_{CC}

* High-impedance state during power up or power down

□ This is the increase in supply current for each input that is at the specified TTL voltage level rather than V_{CC} or GND.

PRODUCT PREVIEW information concerns products in the formative or design phase of development. Characteristic data and other specifications are design goals. Texas Instruments reserves the right to change or discontinue these products without notice.



POST OFFICE BOX 655303 • DALLAS, TEXAS 75265

SN54ALVTH16245, SN74ALVTH16245 2.5-V/3.3-V 16-BIT BUS TRANSCEIVERS WITH 3-STATE OUTPUTS

SCES066G – JUNE 1996 – REVISED APRIL 2002

switching characteristics over recommended operating free-air temperature range, $C_L = 30$ pF, $V_{CC} = 2.5$ V \pm 0.2 V (unless otherwise noted) (see Figure 1)

PARAMETER	FROM (INPUT)	TO (OUTPUT)	SN54ALVTH16245		SN74ALVTH16245		UNIT
			MIN	MAX	MIN	MAX	
t_{PLH}	A or B	B or A	0.5	3.6	0.5	3.6	ns
t_{PHL}			0.5	3.4	0.5	3.4	
t_{PZH}	\overline{OE}	A or B	1.5	4.9	1.5	4.9	ns
t_{PZL}			1	4	1	4	
t_{PHZ}	\overline{OE}	A or B	1.5	4.9	1.5	4.9	ns
t_{PLZ}			1	4.2	1	4.2	

switching characteristics over recommended operating free-air temperature range, $C_L = 50$ pF, $V_{CC} = 3.3$ V \pm 0.3 V (unless otherwise noted) (see Figure 1)

PARAMETER	FROM (INPUT)	TO (OUTPUT)	SN54ALVTH16245		SN74ALVTH16245		UNIT
			MIN	MAX	MIN	MAX	
t_{PLH}	A or B	B or A	0.5	3.1	0.5	3.1	ns
t_{PHL}			0.5	2.9	0.5	2.9	
t_{PZH}	\overline{OE}	A or B	1	4.2	1	4.2	ns
t_{PZL}			1	3.5	1	3.5	
t_{PHZ}	\overline{OE}	A or B	1.5	5.3	1.5	5.3	ns
t_{PLZ}			1.5	5	1.5	5	

skew

t_{ps} (pin or transition skew), $t_{ps} = |t_{PHL} - t_{PLH}|$

	$V_{CC} = 2.5$ V	$V_{CC} = 3.3$ V	UNIT
	TYP	TYP	
t_{psmax}	438	118	ps

$t_{OST} = |t_{p\Phi m} - t_{p\Phi n}|$, where Φ is any edge transition (high to low or low to high) measured between any two outputs (m or n) within any given device (see Note 4)

		$V_{CC} = 2.5$ V	$V_{CC} = 3.3$ V	UNIT
		TYP	TYP	
t_{OST}	A-B	227	248	ps
	B-A	223	243	

NOTE 4: One output switching, $T_A = 25^\circ\text{C}$

t_{OSHL}/t_{OSLH} (common edge skew), $t_{OSHL} = |t_{PHLmax} - t_{PHLmin}|$ (output skew for low-to-high transitions), and $t_{OSLH} = |t_{PLHmax} - t_{PLHmin}|$ (output skew for high-to-low transitions) (see Note 4)

		$V_{CC} = 2.5$ V	$V_{CC} = 3.3$ V	UNIT
		TYP	TYP	
t_{OSLH}	A-B	210	145	ps
t_{OSHL}		243	351	
t_{OSLH}	B-A	207	136	ps
t_{OSHL}		238	350	

NOTE 4: One output switching, $T_A = 25^\circ\text{C}$

PRODUCT PREVIEW information concerns products in the formative or design phase of development. Characteristic data and other specifications are design goals. Texas Instruments reserves the right to change or discontinue these products without notice.



SN54ALVTH16245, SN74ALVTH16245 2.5-V/3.3-V 16-BIT BUS TRANSCEIVERS WITH 3-STATE OUTPUTS

SCES066G – JUNE 1996 – REVISED APRIL 2002

PARAMETER MEASUREMENT INFORMATION

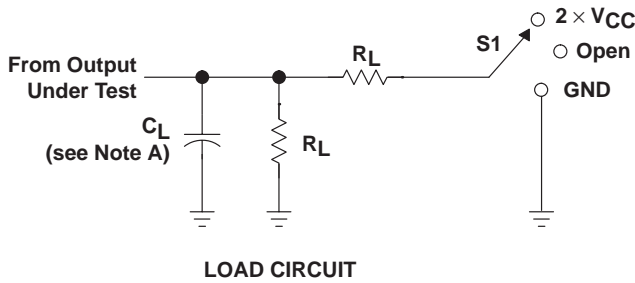

TEST	S1
t_{PLH}/t_{PHL}	Open
t_{PLZ}/t_{PZL}	$2 \times V_{CC}$
t_{PHZ}/t_{PZH}	GND

V_{CC}	C_L	R_L	V_{Δ}
$2.5 \text{ V} \pm 0.2 \text{ V}$	30 pF	500 Ω	0.15 V
$3.3 \text{ V} \pm 0.3 \text{ V}$	50 pF	500 Ω	0.3 V

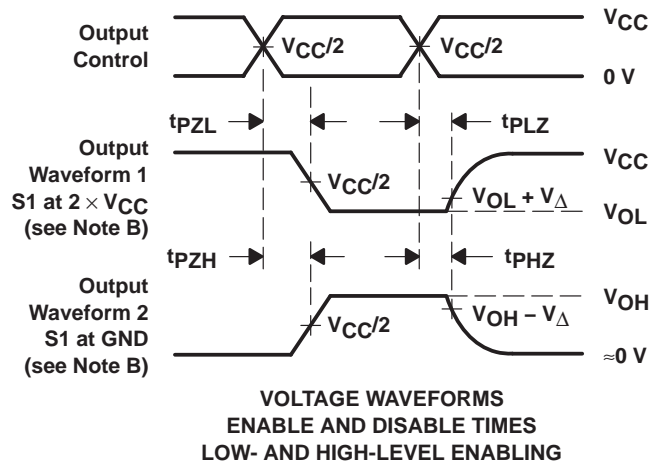
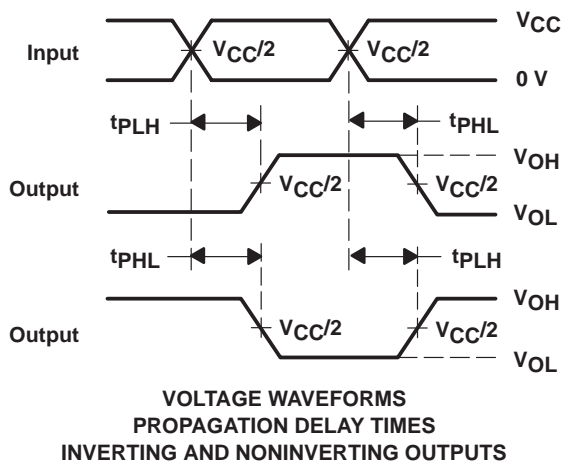
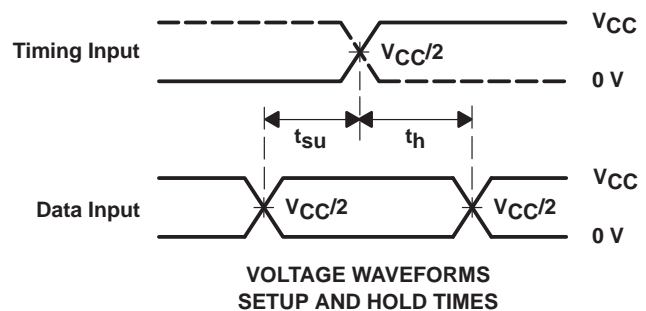
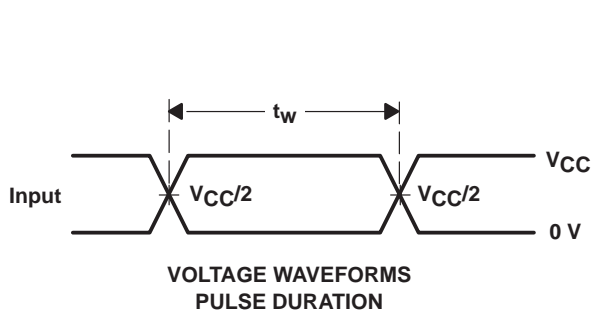

- NOTES:
- C_L includes probe and jig capacitance.
 - Waveform 1 is for an output with internal conditions such that the output is low except when disabled by the output control. Waveform 2 is for an output with internal conditions such that the output is high except when disabled by the output control.
 - All input pulses are supplied by generators having the following characteristics: $PRR \leq 10 \text{ MHz}$, $Z_O = 50 \Omega$, $t_r \leq 2 \text{ ns}$, $t_f \leq 2 \text{ ns}$.
 - The outputs are measured one at a time with one transition per measurement.
 - t_{PLZ} and t_{PHZ} are the same as t_{dis} .
 - t_{PZL} and t_{PZH} are the same as t_{en} .
 - t_{PLH} and t_{PHL} are the same as t_{pd} .
 - All parameters and waveforms are not applicable to all devices.

Figure 1. Load Circuit and Voltage Waveforms

PACKAGING INFORMATION

Orderable Device	Status ⁽¹⁾	Package Type	Package Drawing	Pins	Package Qty	Eco Plan ⁽²⁾	Lead/ Ball Finish	MSL Peak Temp ⁽³⁾	Samples (Requires Login)
74ALVTH16245DLG4	ACTIVE	SSOP	DL	48	25	Green (RoHS & no Sb/Br)	CU NIPDAU	Level-1-260C-UNLIM	
74ALVTH16245DLRG4	ACTIVE	SSOP	DL	48	1000	Green (RoHS & no Sb/Br)	CU NIPDAU	Level-1-260C-UNLIM	
74ALVTH16245GRE4	ACTIVE	TSSOP	DGG	48	2000	Green (RoHS & no Sb/Br)	CU NIPDAU	Level-1-260C-UNLIM	
74ALVTH16245GRG4	ACTIVE	TSSOP	DGG	48	2000	Green (RoHS & no Sb/Br)	CU NIPDAU	Level-1-260C-UNLIM	
74ALVTH16245VRE4	ACTIVE	TVSOP	DGV	48	2000	Green (RoHS & no Sb/Br)	CU NIPDAU	Level-1-260C-UNLIM	
74ALVTH16245VRG4	ACTIVE	TVSOP	DGV	48	2000	Green (RoHS & no Sb/Br)	CU NIPDAU	Level-1-260C-UNLIM	
74ALVTH16245ZQLR	ACTIVE	BGA MICROSTAR JUNIOR	ZQL	56	1000	Green (RoHS & no Sb/Br)	SNAGCU	Level-1-260C-UNLIM	
SN74ALVTH16245DL	ACTIVE	SSOP	DL	48	25	Green (RoHS & no Sb/Br)	CU NIPDAU	Level-1-260C-UNLIM	
SN74ALVTH16245DLR	ACTIVE	SSOP	DL	48	1000	Green (RoHS & no Sb/Br)	CU NIPDAU	Level-1-260C-UNLIM	
SN74ALVTH16245GR	ACTIVE	TSSOP	DGG	48	2000	Green (RoHS & no Sb/Br)	CU NIPDAU	Level-1-260C-UNLIM	
SN74ALVTH16245KR	LIFEBUY	BGA MICROSTAR JUNIOR	GQL	56	1000	TBD	SNPB	Level-1-240C-UNLIM	
SN74ALVTH16245VR	ACTIVE	TVSOP	DGV	48	2000	Green (RoHS & no Sb/Br)	CU NIPDAU	Level-1-260C-UNLIM	

⁽¹⁾ The marketing status values are defined as follows:

ACTIVE: Product device recommended for new designs.

LIFEBUY: TI has announced that the device will be discontinued, and a lifetime-buy period is in effect.

NRND: Not recommended for new designs. Device is in production to support existing customers, but TI does not recommend using this part in a new design.

PREVIEW: Device has been announced but is not in production. Samples may or may not be available.

OBSOLETE: TI has discontinued the production of the device.

⁽²⁾ Eco Plan - The planned eco-friendly classification: Pb-Free (RoHS), Pb-Free (RoHS Exempt), or Green (RoHS & no Sb/Br) - please check <http://www.ti.com/productcontent> for the latest availability information and additional product content details.

TBD: The Pb-Free/Green conversion plan has not been defined.

Pb-Free (RoHS): TI's terms "Lead-Free" or "Pb-Free" mean semiconductor products that are compatible with the current RoHS requirements for all 6 substances, including the requirement that lead not exceed 0.1% by weight in homogeneous materials. Where designed to be soldered at high temperatures, TI Pb-Free products are suitable for use in specified lead-free processes.

Pb-Free (RoHS Exempt): This component has a RoHS exemption for either 1) lead-based flip-chip solder bumps used between the die and package, or 2) lead-based die adhesive used between the die and leadframe. The component is otherwise considered Pb-Free (RoHS compatible) as defined above.

Green (RoHS & no Sb/Br): TI defines "Green" to mean Pb-Free (RoHS compatible), and free of Bromine (Br) and Antimony (Sb) based flame retardants (Br or Sb do not exceed 0.1% by weight in homogeneous material)

⁽³⁾ MSL, Peak Temp. -- The Moisture Sensitivity Level rating according to the JEDEC industry standard classifications, and peak solder temperature.

Important Information and Disclaimer: The information provided on this page represents TI's knowledge and belief as of the date that it is provided. TI bases its knowledge and belief on information provided by third parties, and makes no representation or warranty as to the accuracy of such information. Efforts are underway to better integrate information from third parties. TI has taken and continues to take reasonable steps to provide representative and accurate information but may not have conducted destructive testing or chemical analysis on incoming materials and chemicals. TI and TI suppliers consider certain information to be proprietary, and thus CAS numbers and other limited information may not be available for release.

In no event shall TI's liability arising out of such information exceed the total purchase price of the TI part(s) at issue in this document sold by TI to Customer on an annual basis.

TAPE AND REEL INFORMATION
REEL DIMENSIONS

TAPE DIMENSIONS

A0	Dimension designed to accommodate the component width
B0	Dimension designed to accommodate the component length
K0	Dimension designed to accommodate the component thickness
W	Overall width of the carrier tape
P1	Pitch between successive cavity centers

TAPE AND REEL INFORMATION

*All dimensions are nominal

Device	Package Type	Package Drawing	Pins	SPQ	Reel Diameter (mm)	Reel Width W1 (mm)	A0 (mm)	B0 (mm)	K0 (mm)	P1 (mm)	W (mm)	Pin1 Quadrant
74ALVTH16245ZQLR	BGA MICROSTAR JUNIOR	ZQL	56	1000	330.0	16.4	4.8	7.3	1.5	8.0	16.0	Q1
SN74ALVTH16245DLR	SSOP	DL	48	1000	330.0	32.4	11.35	16.2	3.1	16.0	32.0	Q1
SN74ALVTH16245GR	TSSOP	DGG	48	2000	330.0	24.4	8.6	15.8	1.8	12.0	24.0	Q1
SN74ALVTH16245KR	BGA MICROSTAR JUNIOR	GQL	56	1000	330.0	16.4	4.8	7.3	1.45	8.0	16.0	Q1
SN74ALVTH16245VR	TVSOP	DGV	48	2000	330.0	16.4	7.1	10.2	1.6	12.0	16.0	Q1

TAPE AND REEL BOX DIMENSIONS

*All dimensions are nominal

Device	Package Type	Package Drawing	Pins	SPQ	Length (mm)	Width (mm)	Height (mm)
74ALVTH16245ZQLR	BGA MICROSTAR JUNIOR	ZQL	56	1000	333.2	345.9	28.6
SN74ALVTH16245DLR	SSOP	DL	48	1000	367.0	367.0	55.0
SN74ALVTH16245GR	TSSOP	DGG	48	2000	367.0	367.0	45.0
SN74ALVTH16245KR	BGA MICROSTAR JUNIOR	GQL	56	1000	333.2	345.9	28.6
SN74ALVTH16245VR	TVSOP	DGV	48	2000	367.0	367.0	38.0

ZQL (R-PBGA-N56)

PLASTIC BALL GRID ARRAY

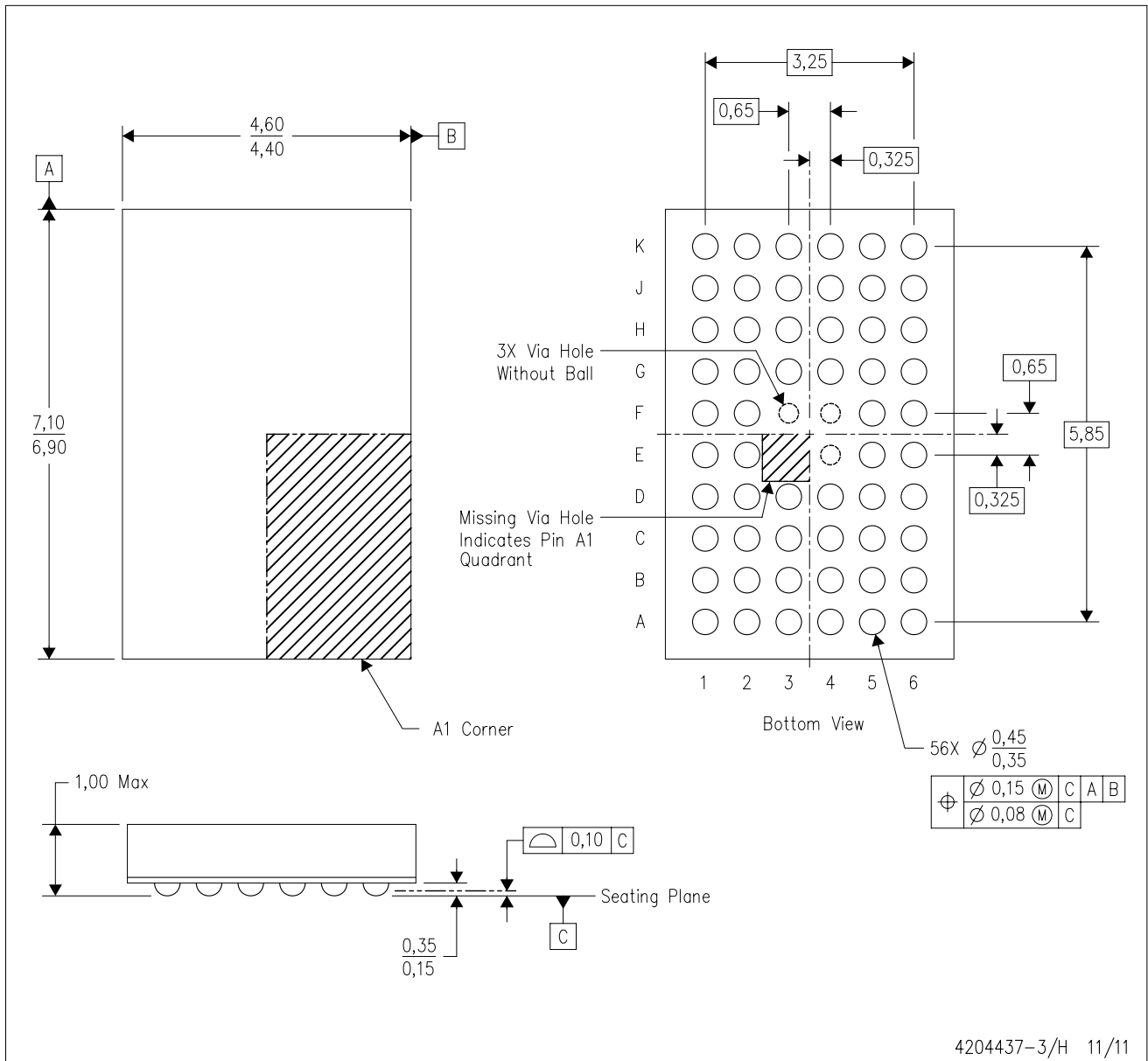

- NOTES:
- A. All linear dimensions are in millimeters. Dimensioning and tolerancing per ASME Y14.5M-1994.
 - B. This drawing is subject to change without notice.
 - C. Falls within JEDEC MO-285 variation BA-2.
 - D. This package is Pb-free. Refer to the 56 GQL package (drawing 4200583) for tin-lead (SnPb).

DGV (R-PDSO-G**)

PLASTIC SMALL-OUTLINE

24 PINS SHOWN



4073251/E 08/00

- NOTES: A. All linear dimensions are in millimeters.
 B. This drawing is subject to change without notice.
 C. Body dimensions do not include mold flash or protrusion, not to exceed 0,15 per side.
 D. Falls within JEDEC: 24/48 Pins – MO-153
 14/16/20/56 Pins – MO-194

GQL (R-PBGA-N56)

PLASTIC BALL GRID ARRAY

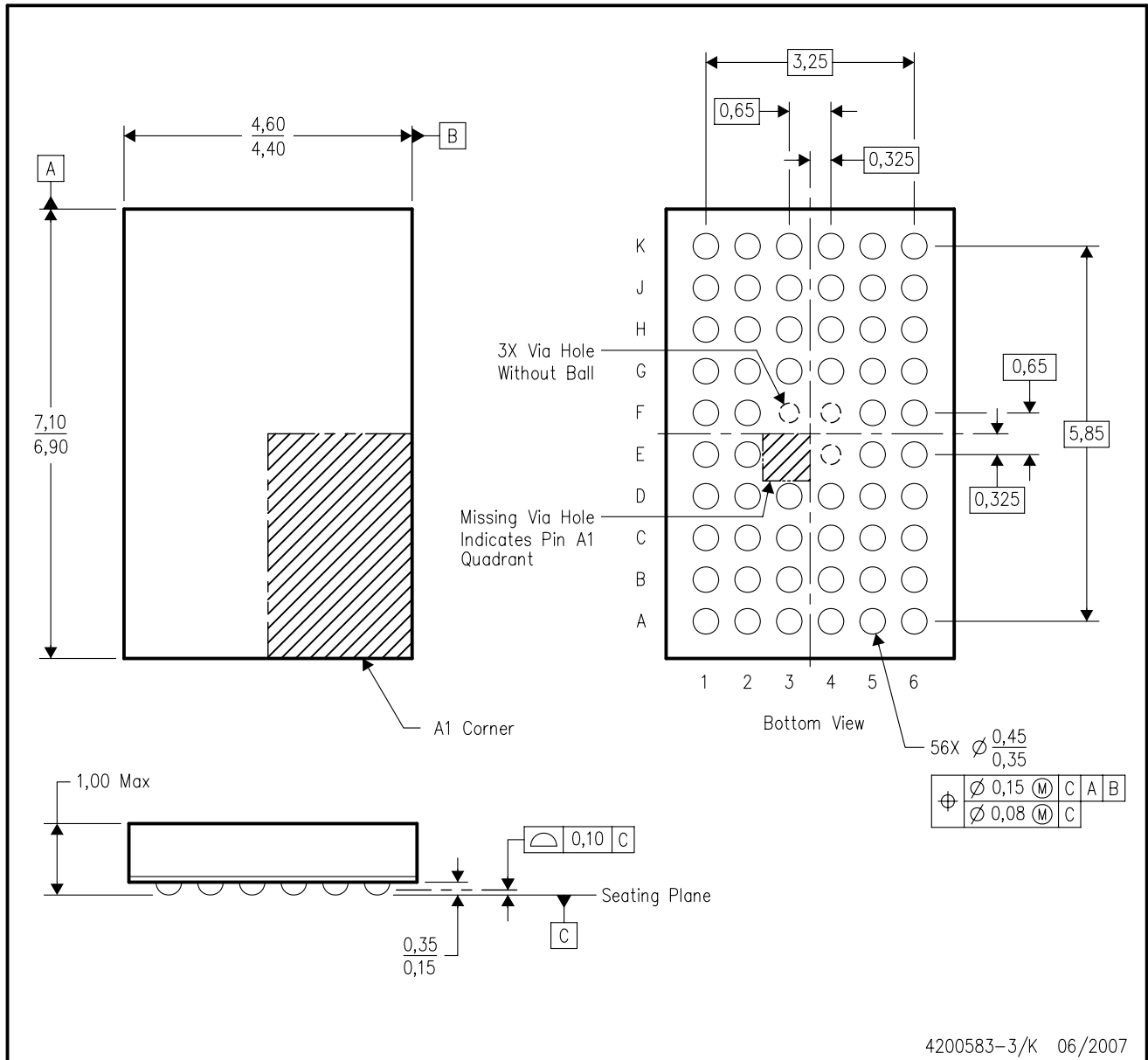

- NOTES:
- A. All linear dimensions are in millimeters. Dimensioning and tolerancing per ASME Y14.5M-1994.
 - B. This drawing is subject to change without notice.
 - C. Falls within JEDEC MO-285 variation BA-2.
 - D. This package is tin-lead (SnPb). Refer to the 56 ZQL package (drawing 4204437) for lead-free.

DL (R-PDSO-G**)

PLASTIC SMALL-OUTLINE PACKAGE

48 PINS SHOWN

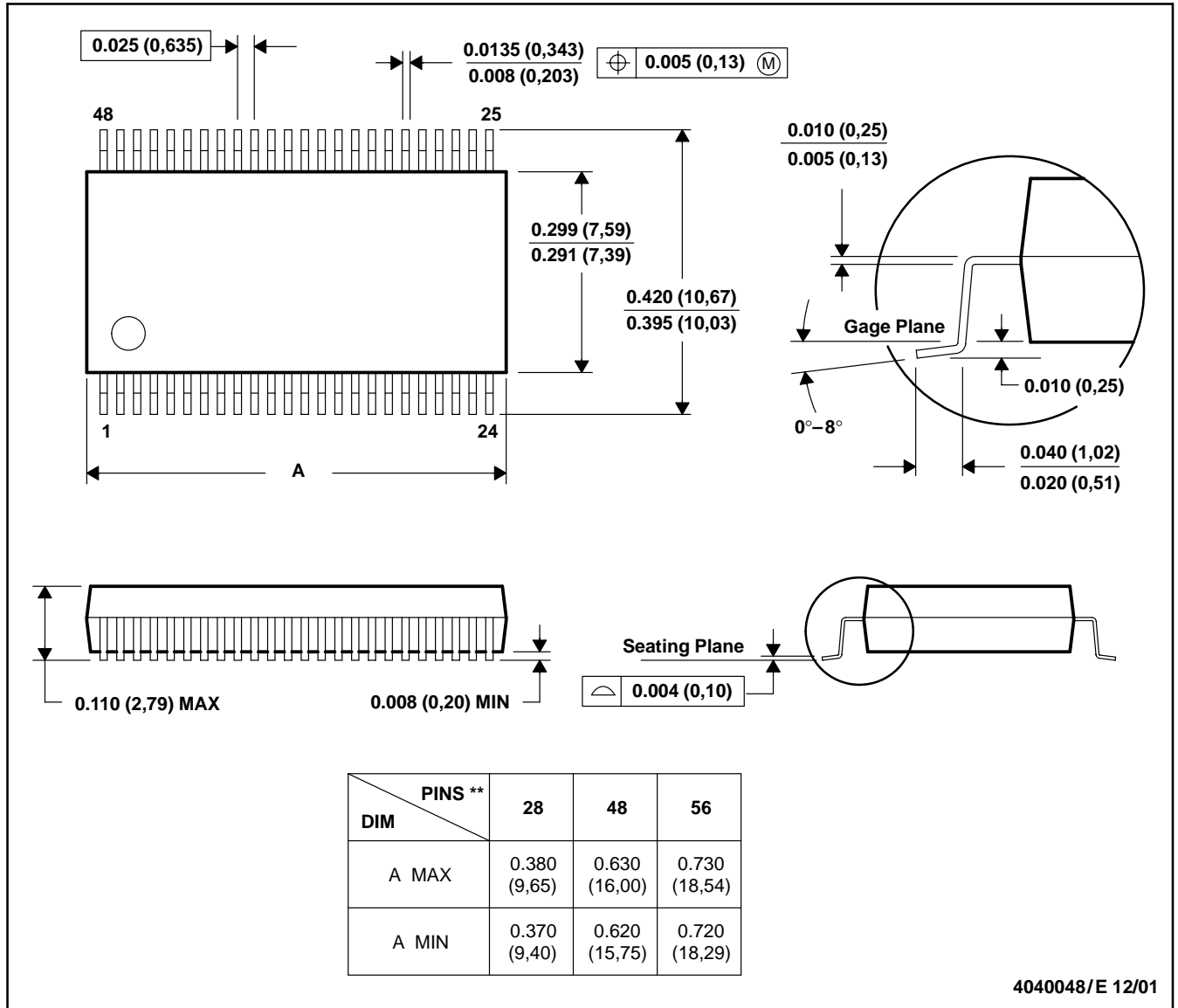

- NOTES: A. All linear dimensions are in inches (millimeters).
 B. This drawing is subject to change without notice.
 C. Body dimensions do not include mold flash or protrusion not to exceed 0.006 (0,15).
 D. Falls within JEDEC MO-118

DGG (R-PDSO-G**)

PLASTIC SMALL-OUTLINE PACKAGE

48 PINS SHOWN



- NOTES: A. All linear dimensions are in millimeters.
 B. This drawing is subject to change without notice.
 C. Body dimensions do not include mold protrusion not to exceed 0,15.
 D. Falls within JEDEC MO-153

IMPORTANT NOTICE

Texas Instruments Incorporated and its subsidiaries (TI) reserve the right to make corrections, enhancements, improvements and other changes to its semiconductor products and services per JESD46C and to discontinue any product or service per JESD48B. Buyers should obtain the latest relevant information before placing orders and should verify that such information is current and complete. All semiconductor products (also referred to herein as "components") are sold subject to TI's terms and conditions of sale supplied at the time of order acknowledgment.

TI warrants performance of its components to the specifications applicable at the time of sale, in accordance with the warranty in TI's terms and conditions of sale of semiconductor products. Testing and other quality control techniques are used to the extent TI deems necessary to support this warranty. Except where mandated by applicable law, testing of all parameters of each component is not necessarily performed.

TI assumes no liability for applications assistance or the design of Buyers' products. Buyers are responsible for their products and applications using TI components. To minimize the risks associated with Buyers' products and applications, Buyers should provide adequate design and operating safeguards.

TI does not warrant or represent that any license, either express or implied, is granted under any patent right, copyright, mask work right, or other intellectual property right relating to any combination, machine, or process in which TI components or services are used. Information published by TI regarding third-party products or services does not constitute a license to use such products or services or a warranty or endorsement thereof. Use of such information may require a license from a third party under the patents or other intellectual property of the third party, or a license from TI under the patents or other intellectual property of TI.

Reproduction of significant portions of TI information in TI data books or data sheets is permissible only if reproduction is without alteration and is accompanied by all associated warranties, conditions, limitations, and notices. TI is not responsible or liable for such altered documentation. Information of third parties may be subject to additional restrictions.

Resale of TI components or services with statements different from or beyond the parameters stated by TI for that component or service voids all express and any implied warranties for the associated TI component or service and is an unfair and deceptive business practice. TI is not responsible or liable for any such statements.

Buyer acknowledges and agrees that it is solely responsible for compliance with all legal, regulatory and safety-related requirements concerning its products, and any use of TI components in its applications, notwithstanding any applications-related information or support that may be provided by TI. Buyer represents and agrees that it has all the necessary expertise to create and implement safeguards which anticipate dangerous consequences of failures, monitor failures and their consequences, lessen the likelihood of failures that might cause harm and take appropriate remedial actions. Buyer will fully indemnify TI and its representatives against any damages arising out of the use of any TI components in safety-critical applications.

In some cases, TI components may be promoted specifically to facilitate safety-related applications. With such components, TI's goal is to help enable customers to design and create their own end-product solutions that meet applicable functional safety standards and requirements. Nonetheless, such components are subject to these terms.

No TI components are authorized for use in FDA Class III (or similar life-critical medical equipment) unless authorized officers of the parties have executed a special agreement specifically governing such use.

Only those TI components which TI has specifically designated as military grade or "enhanced plastic" are designed and intended for use in military/aerospace applications or environments. Buyer acknowledges and agrees that any military or aerospace use of TI components which have **not** been so designated is solely at the Buyer's risk, and that Buyer is solely responsible for compliance with all legal and regulatory requirements in connection with such use.

TI has specifically designated certain components which meet ISO/TS16949 requirements, mainly for automotive use. Components which have not been so designated are neither designed nor intended for automotive use; and TI will not be responsible for any failure of such components to meet such requirements.

Products

Audio	www.ti.com/audio
Amplifiers	amplifier.ti.com
Data Converters	dataconverter.ti.com
DLP® Products	www.dlp.com
DSP	dsp.ti.com
Clocks and Timers	www.ti.com/clocks
Interface	interface.ti.com
Logic	logic.ti.com
Power Mgmt	power.ti.com
Microcontrollers	microcontroller.ti.com
RFID	www.ti-rfid.com
OMAP Mobile Processors	www.ti.com/omap
Wireless Connectivity	www.ti.com/wirelessconnectivity

Applications

Automotive and Transportation	www.ti.com/automotive
Communications and Telecom	www.ti.com/communications
Computers and Peripherals	www.ti.com/computers
Consumer Electronics	www.ti.com/consumer-apps
Energy and Lighting	www.ti.com/energy
Industrial	www.ti.com/industrial
Medical	www.ti.com/medical
Security	www.ti.com/security
Space, Avionics and Defense	www.ti.com/space-avionics-defense
Video and Imaging	www.ti.com/video

TI E2E Community e2e.ti.com