

SN74ALVCHS162830 1-BIT TO 2-BIT ADDRESS DRIVER WITH 3-STATE OUTPUTS

SCES097G – APRIL 1997 – REVISED FEBRUARY 2002

- Member of the Texas Instruments Widebus™ Family
- Output Ports Have Equivalent 26-Ω Series Resistors, So No External Resistors Are Required
- Diodes on Inputs Clamp Overshoot
- Bus Hold on Data Inputs Eliminates the Need for External Pullup/Pulldown Resistors
- Latch-Up Performance Exceeds 250 mA Per JESD 17
- ESD Protection Exceeds JESD 22
 - 2000-V Human-Body Model (A114-A)
 - 200-V Machine Model (A115-A)

description

This 1-bit to 2-bit address driver is designed for 2.3-V to 3.6-V V_{CC} operation.

Diodes to V_{CC} have been added on the inputs to clamp overshoot.

Active bus-hold circuitry holds unused or undriven inputs at a valid logic state. Use of pullup or pulldown resistors with the bus-hold circuitry is not recommended.

The outputs, which are designed to sink up to 12 mA, include equivalent 26-Ω series resistors to reduce overshoot and undershoot.

To ensure the high-impedance state during power up or power down, the output-enable (\overline{OE}) input should be tied to V_{CC} through a pullup resistor; the minimum value of the resistor is determined by the current-sinking capability of the driver.

DBB PACKAGE
(TOP VIEW)

2Y2	1	80	1Y3
1Y2	2	79	2Y3
GND	3	78	GND
2Y1	4	77	1Y4
1Y1	5	76	2Y4
V_{CC}	6	75	V_{CC}
A1	7	74	1Y5
A2	8	73	2Y5
GND	9	72	GND
A3	10	71	1Y6
A4	11	70	2Y6
GND	12	69	GND
A5	13	68	1Y7
A6	14	67	2Y7
V_{CC}	15	66	V_{CC}
A7	16	65	1Y8
A8	17	64	2Y8
GND	18	63	GND
A9	19	62	1Y9
$\overline{OE1}$	20	61	2Y9
$\overline{OE2}$	21	60	1Y10
A10	22	59	2Y10
GND	23	58	GND
A11	24	57	1Y11
A12	25	56	2Y11
V_{CC}	26	55	V_{CC}
A13	27	54	1Y12
A14	28	53	2Y12
GND	29	52	GND
A15	30	51	1Y13
A16	31	50	2Y13
GND	32	49	GND
A17	33	48	1Y14
A18	34	47	2Y14
V_{CC}	35	46	V_{CC}
2Y18	36	45	1Y15
1Y18	37	44	2Y15
GND	38	43	GND
2Y17	39	42	1Y16
1Y17	40	41	2Y16



Please be aware that an important notice concerning availability, standard warranty, and use in critical applications of Texas Instruments semiconductor products and disclaimers thereto appears at the end of this data sheet.

Widebus is a trademark of Texas Instruments.

PRODUCTION DATA information is current as of publication date. Products conform to specifications per the terms of Texas Instruments standard warranty. Production processing does not necessarily include testing of all parameters.



POST OFFICE BOX 655303 • DALLAS, TEXAS 75265

Copyright © 2002, Texas Instruments Incorporated

SN74ALVCHS162830
1-BIT TO 2-BIT ADDRESS DRIVER
WITH 3-STATE OUTPUTS

SCES097G – APRIL 1997 – REVISED FEBRUARY 2002

FUNCTION TABLE

INPUTS			OUTPUTS	
OE1	OE2	A	1Yn	2Yn
L	H	H	H	Z
L	H	L	L	Z
H	L	H	Z	H
H	L	L	Z	L
L	L	H	H	H
L	L	L	L	L
H	H	X	Z	Z

logic diagram (positive logic)

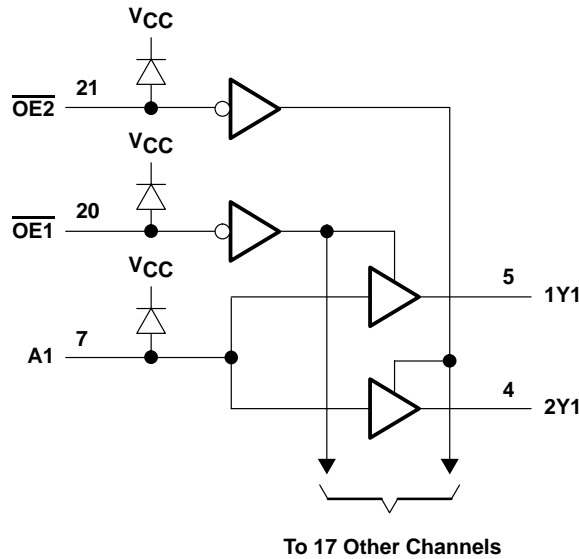

absolute maximum ratings over operating free-air temperature range (unless otherwise noted)†

Supply voltage range, V_{CC}	-0.5 V to 4.6 V
Input voltage range, V_I (see Note 1)	-0.5 V to 4.6 V
Output voltage range, V_O (see Notes 1 and 2)	-0.5 V to $V_{CC} + 0.5$ V
Input clamp current, I_{IK} ($V_I < 0$)	-50 mA
Output clamp current, I_{OK} ($V_O < 0$)	-50 mA
Continuous output current, I_O	± 50 mA
Continuous current through each V_{CC} or GND	± 100 mA
Package thermal impedance, θ_{JA} (see Note 3)	64°C/W
Storage temperature range, T_{stg}	-65°C to 150°C

† Stresses beyond those listed under “absolute maximum ratings” may cause permanent damage to the device. These are stress ratings only, and functional operation of the device at these or any other conditions beyond those indicated under “recommended operating conditions” is not implied. Exposure to absolute-maximum-rated conditions for extended periods may affect device reliability.

- NOTES: 1. The input negative-voltage and output voltage ratings may be exceeded if the input and output current ratings are observed.
 2. This value is limited to 4.6 V maximum.
 3. The package thermal impedance is calculated in accordance with JESD 51-7.



SN74ALVCHS162830
1-BIT TO 2-BIT ADDRESS DRIVER
WITH 3-STATE OUTPUTS

SCES097G – APRIL 1997 – REVISED FEBRUARY 2002

recommended operating conditions (see Note 4)

		MIN	MAX	UNIT
V _{CC}	Supply voltage	2.3	3.6	V
V _{IH}	High-level input voltage	V _{CC} = 2.3 V to 2.7 V	1.7	V
		V _{CC} = 2.7 V to 3.6 V	2	
V _{IL}	Low-level input voltage	V _{CC} = 2.3 V to 2.7 V	0.7	V
		V _{CC} = 2.7 V to 3.6 V	0.8	
V _I	Input voltage	0	V _{CC}	V
V _O	Output voltage	0	V _{CC}	V
I _{OH}	High-level output current	V _{CC} = 2.3 V	-6	mA
		V _{CC} = 2.7 V	-8	
		V _{CC} = 3 V	-12	
I _{OL}	Low-level output current	V _{CC} = 2.3 V	6	mA
		V _{CC} = 2.7 V	8	
		V _{CC} = 3 V	12	
Δt/Δv	Input transition rise or fall rate		10	ns/V
T _A	Operating free-air temperature	-40	85	°C

NOTE 4: All unused control inputs of the device must be held at V_{CC} or GND to ensure proper device operation. Refer to the TI application report, *Implications of Slow or Floating CMOS Inputs*, literature number SCBA004.

SN74ALVCHS162830
1-BIT TO 2-BIT ADDRESS DRIVER
WITH 3-STATE OUTPUTS

SCES097G – APRIL 1997 – REVISED FEBRUARY 2002

electrical characteristics over recommended operating free-air temperature range (unless otherwise noted)

PARAMETER		TEST CONDITIONS	V _{CC}	MIN	TYP†	MAX	UNIT
V _{IK}		I _I = -18 mA	2.3 V			-1.2	V
		I _I = 18 mA	2.3 V			V _{CC} +1.2	
V _{OH}		I _{OH} = -100 μA	2.3 V to 3.6 V			V _{CC} -0.2	V
		I _{OH} = -4 mA, V _{IH} = 1.7 V	2.3 V		1.9		
		I _{OH} = -6 mA	V _{IH} = 1.7 V	2.3 V		1.7	
			V _{IH} = 2 V	3 V		2.4	
		I _{OH} = -8 mA, V _{IH} = 2 V	2.7 V		2		
	I _{OH} = -12 mA, V _{IH} = 2 V	3 V		2			
V _{OL}		I _{OL} = 100 μA	2.3 V to 3.6 V			0.2	V
		I _{OL} = 4 mA, V _{IL} = 0.7 V	2.3 V			0.4	
		I _{OL} = 6 mA	V _{IL} = 0.7 V	2.3 V		0.55	
			V _{IL} = 0.8 V	3 V		0.55	
		I _{OL} = 8 mA, V _{IL} = 0.8 V	2.7 V			0.6	
	I _{OL} = 12 mA, V _{IL} = 0.8 V	3 V			0.8		
I _I		V _I = V _{CC} or GND	3.6 V			±5	μA
I _I (hold)		V _I = 0.7 V	2.3 V		45		μA
		V _I = 1.7 V	2.3 V		-45		
		V _I = 0.8 V	3 V		75		
		V _I = 2 V	3 V		-75		
		V _I = 0 to 3.6 V‡	3.6 V			±500	
I _{OZ}		V _O = V _{CC} or GND	3.6 V			±10	μA
I _{CC}		V _I = V _{CC} or GND, I _O = 0	3.6 V			40	μA
ΔI _{CC}		One input at V _{CC} - 0.6 V, Other inputs at V _{CC} or GND	3 V to 3.6 V			750	μA
C _i	Control inputs	V _I = V _{CC} or GND	3.3 V			5.5	pF
	Data inputs					7	
C _o	Outputs	V _O = V _{CC} or GND	3.3 V			7.5	pF

† All typical values are at V_{CC} = 3.3 V, T_A = 25°C.

‡ This is the bus-hold maximum dynamic current. It is the minimum overdrive current required to switch the input from one state to another.

switching characteristics over recommended operating free-air temperature range (unless otherwise noted) (see Figures 1 and 2)

PARAMETER	FROM (INPUT)	TO (OUTPUT)	V _{CC} = 2.5 V ± 0.2 V		V _{CC} = 2.7 V		V _{CC} = 3.3 V ± 0.3 V		UNIT
			MIN	MAX	MIN	MAX	MIN	MAX	
t _{pd}	A	Y	1.2	3.8		4	1.7	3.5	ns
t _{en}	\overline{OE}	Y	1	5.7		5.7	1	4.8	ns
t _{dis}	\overline{OE}	Y	1	4.9		5.4	1.7	5.2	ns

operating characteristics, T_A = 25°C

PARAMETER		TEST CONDITIONS	V _{CC} = 2.5 V		V _{CC} = 3.3 V		UNIT
			TYP	TYP	TYP	TYP	
C _{pd}	Power dissipation capacitance per bit (two outputs switching)	All outputs enabled	C _L = 0, f = 10 MHz	49	53	pF	
		All outputs disabled		6	7.5		



PARAMETER MEASUREMENT INFORMATION

$V_{CC} = 2.5\text{ V} \pm 0.2\text{ V}$

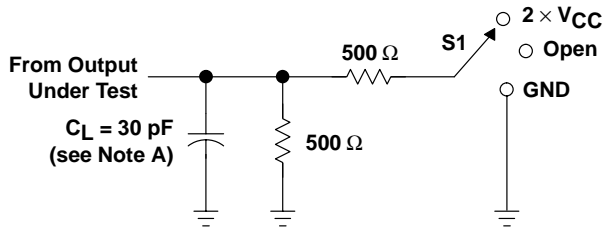

LOAD CIRCUIT

TEST	S1
t_{pd}	Open
t_{PLZ}/t_{PZL}	2 \times V_{CC}
t_{PHZ}/t_{PZH}	GND

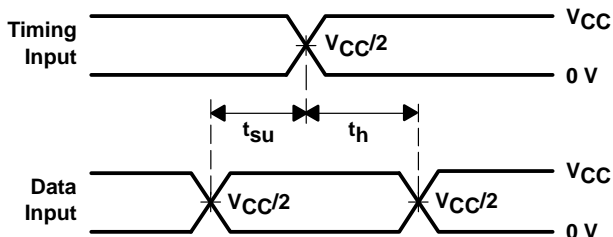

VOLTAGE WAVEFORMS
 SETUP AND HOLD TIMES

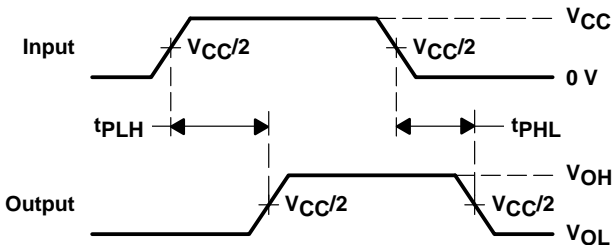

VOLTAGE WAVEFORMS
 PROPAGATION DELAY TIMES

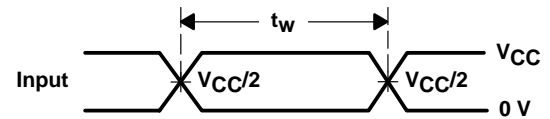

VOLTAGE WAVEFORMS
 PULSE DURATION

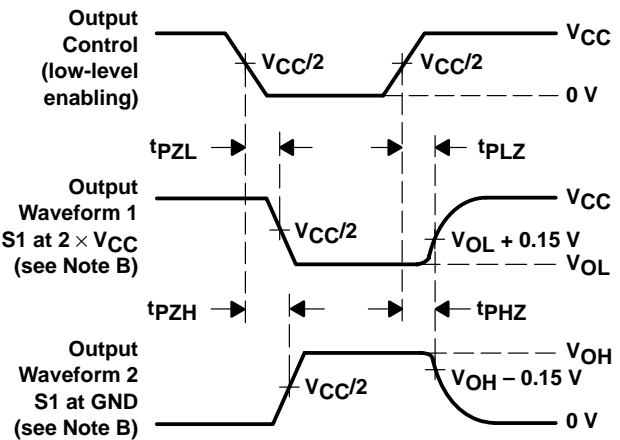

VOLTAGE WAVEFORMS
 ENABLE AND DISABLE TIMES

- NOTES: A. C_L includes probe and jig capacitance.
 B. Waveform 1 is for an output with internal conditions such that the output is low except when disabled by the output control. Waveform 2 is for an output with internal conditions such that the output is high except when disabled by the output control.
 C. All input pulses are supplied by generators having the following characteristics: PRR \leq 10 MHz, $Z_O = 50\ \Omega$, $t_r \leq 2\text{ ns}$, $t_f \leq 2\text{ ns}$.
 D. The outputs are measured one at a time with one transition per measurement.
 E. t_{PLZ} and t_{PHZ} are the same as t_{dis} .
 F. t_{PZL} and t_{PZH} are the same as t_{en} .
 G. t_{PLH} and t_{PHL} are the same as t_{pd} .

Figure 1. Load Circuit and Voltage Waveforms

SN74ALVCHS162830
1-BIT TO 2-BIT ADDRESS DRIVER
WITH 3-STATE OUTPUTS

SCES097G – APRIL 1997 – REVISED FEBRUARY 2002

PARAMETER MEASUREMENT INFORMATION

$V_{CC} = 2.7\text{ V AND } 3.3\text{ V} \pm 0.3\text{ V}$

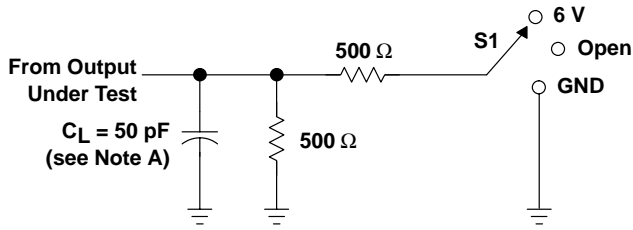

LOAD CIRCUIT

TEST	S1
t_{pd}	Open
t_{PLZ}/t_{PZL}	6 V
t_{PHZ}/t_{PZH}	GND

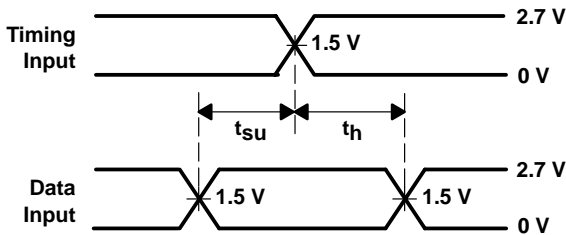

**VOLTAGE WAVEFORMS
 SETUP AND HOLD TIMES**

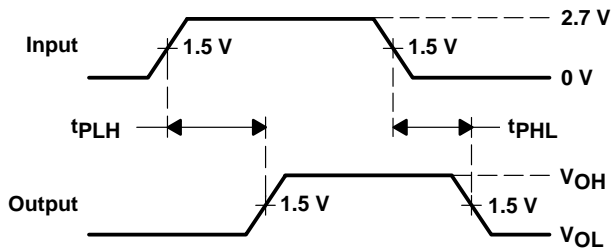

**VOLTAGE WAVEFORMS
 PROPAGATION DELAY TIMES**

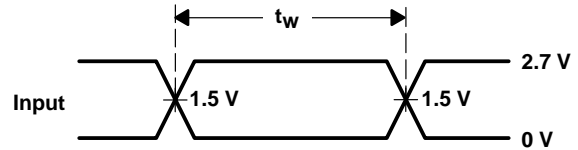

**VOLTAGE WAVEFORMS
 PULSE DURATION**

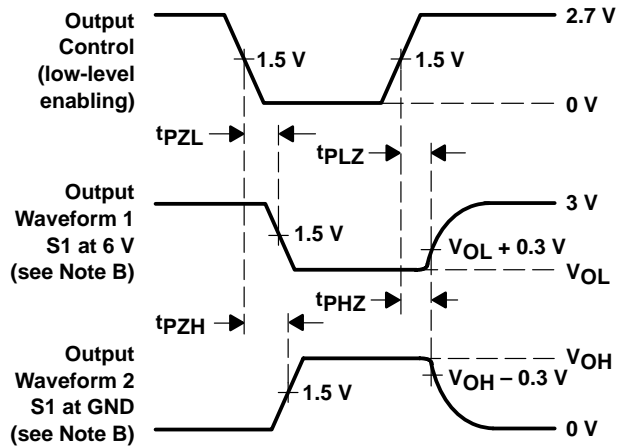

**VOLTAGE WAVEFORMS
 ENABLE AND DISABLE TIMES**

- NOTES: A. C_L includes probe and jig capacitance.
 B. Waveform 1 is for an output with internal conditions such that the output is low except when disabled by the output control. Waveform 2 is for an output with internal conditions such that the output is high except when disabled by the output control.
 C. All input pulses are supplied by generators having the following characteristics: $PRR \leq 10\text{ MHz}$, $Z_O = 50\ \Omega$, $t_r \leq 2.5\text{ ns}$, $t_f \leq 2.5\text{ ns}$.
 D. The outputs are measured one at a time with one transition per measurement.
 E. t_{PLZ} and t_{PHZ} are the same as t_{dis} .
 F. t_{PZL} and t_{PZH} are the same as t_{en} .
 G. t_{PLH} and t_{PHL} are the same as t_{pd} .

Figure 2. Load Circuit and Voltage Waveforms

IMPORTANT NOTICE

Texas Instruments Incorporated and its subsidiaries (TI) reserve the right to make corrections, modifications, enhancements, improvements, and other changes to its products and services at any time and to discontinue any product or service without notice. Customers should obtain the latest relevant information before placing orders and should verify that such information is current and complete. All products are sold subject to TI's terms and conditions of sale supplied at the time of order acknowledgment.

TI warrants performance of its hardware products to the specifications applicable at the time of sale in accordance with TI's standard warranty. Testing and other quality control techniques are used to the extent TI deems necessary to support this warranty. Except where mandated by government requirements, testing of all parameters of each product is not necessarily performed.

TI assumes no liability for applications assistance or customer product design. Customers are responsible for their products and applications using TI components. To minimize the risks associated with customer products and applications, customers should provide adequate design and operating safeguards.

TI does not warrant or represent that any license, either express or implied, is granted under any TI patent right, copyright, mask work right, or other TI intellectual property right relating to any combination, machine, or process in which TI products or services are used. Information published by TI regarding third-party products or services does not constitute a license from TI to use such products or services or a warranty or endorsement thereof. Use of such information may require a license from a third party under the patents or other intellectual property of the third party, or a license from TI under the patents or other intellectual property of TI.

Reproduction of information in TI data books or data sheets is permissible only if reproduction is without alteration and is accompanied by all associated warranties, conditions, limitations, and notices. Reproduction of this information with alteration is an unfair and deceptive business practice. TI is not responsible or liable for such altered documentation.

Resale of TI products or services with statements different from or beyond the parameters stated by TI for that product or service voids all express and any implied warranties for the associated TI product or service and is an unfair and deceptive business practice. TI is not responsible or liable for any such statements.

Mailing Address:

Texas Instruments
Post Office Box 655303
Dallas, Texas 75265