

- Member of the Texas Instruments Widebus™ Family
- Low-Power Advanced CMOS Technology
- Operates From 3-V to 3.6-V  $V_{CC}$
- Load Clock and Unload Clock Can Be Asynchronous or Coincident
- Full, Empty, and Half-Full Flags
- Programmable Almost-Full/Almost-Empty Flag
- Fast Access Times of 18 ns With a 50-pF Load and All Data Outputs Switching Simultaneously
- Data Rates up to 40 MHz
- 3-State Outputs
- Pin-to-Pin Compatible With SN74ACT7804, SN74ACT7806, and SN74ACT7814
- Packaged in Shrink Small-Outline 300-mil Package Using 25-mil Center-to-Center Spacing

## description

A FIFO memory is a storage device that allows data to be written into and read from its array at independent data rates. The SN74ALVC7814 is an 18-bit FIFO with high speed and fast access times. Data is processed at rates up to 40 MHz with access times of 18 ns in a bit-parallel format. These memories are designed for 3-V to 3.6-V  $V_{CC}$  operation.

Data is written into memory on a low-to-high transition of the load clock (LDCK) and is read out on a low-to-high transition of the unload clock (UNCK). The memory is full when the number of words clocked in exceeds the number of words clocked out by 64. When the memory is full, LDCK has no effect on the data residing in memory. When the memory is empty, UNCK has no effect.

Status of the FIFO memory is monitored by the full ( $\overline{FULL}$ ), empty ( $\overline{EMPTY}$ ), half-full (HF), and almost-full/almost-empty (AF/AE) flags. The  $\overline{FULL}$  output is low when the memory is full and high when the memory is not full. The  $\overline{EMPTY}$  output is low when the memory is empty and high when it is not empty. The HF output is high whenever the FIFO contains 32 or more words and low when it contains 31 or fewer words. The AF/AE status flag is a programmable flag. The first one or two low-to-high transitions of LDCK after reset are used to program the almost-empty offset value (X) and the almost-full offset value (Y) if program enable ( $\overline{PEN}$ ) is low. The AF/AE flag is high when the FIFO contains X or fewer words or (64 – Y) or more words. The AF/AE flag is low when the FIFO contains between (X + 1) and (63 – Y) words.

## DL PACKAGE (TOP VIEW)

RESET	1	56	OE
D17	2	55	Q17
D16	3	54	Q16
D15	4	53	Q15
D14	5	52	GND
D13	6	51	Q14
D12	7	50	$V_{CC}$
D11	8	49	Q13
D10	9	48	Q12
$V_{CC}$	10	47	Q11
D9	11	46	Q10
D8	12	45	Q9
GND	13	44	GND
D7	14	43	Q8
D6	15	42	Q7
D5	16	41	Q6
D4	17	40	Q5
D3	18	39	$V_{CC}$
D2	19	38	Q4
D1	20	37	Q3
D0	21	36	Q2
HF	22	35	GND
$\overline{PEN}$	23	34	Q1
AF/AE	24	33	Q0
LDCK	25	32	UNCK
NC	26	31	NC
NC	27	30	NC
$\overline{FULL}$	28	29	$\overline{EMPTY}$

NC – No internal connection



Please be aware that an important notice concerning availability, standard warranty, and use in critical applications of Texas Instruments semiconductor products and disclaimers thereto appears at the end of this data sheet.

Widebus is a trademark of Texas Instruments Incorporated.

PRODUCTION DATA information is current as of publication date. Products conform to specifications per the terms of Texas Instruments standard warranty. Production processing does not necessarily include testing of all parameters.

 **TEXAS  
INSTRUMENTS**

POST OFFICE BOX 655303 • DALLAS, TEXAS 75265

Copyright © 1998, Texas Instruments Incorporated

# SN74ALVC7814

64 × 18

## LOW-POWER FIRST-IN, FIRST-OUT MEMORY

SCAS592A – OCTOBER 1997 – REVISED APRIL 1998

### description (continued)

A low level on the reset ( $\overline{\text{RESET}}$ ) resets the internal stack pointers and sets  $\overline{\text{FULL}}$  high, AF/AE high, HF low, and  $\overline{\text{EMPTY}}$  low. The Q outputs are not reset to any specific logic level. The FIFO must be reset on power up. The first word loaded into empty memory causes  $\overline{\text{EMPTY}}$  to go high and the data to appear on the Q outputs. The data outputs are in the high-impedance state when the output-enable ( $\overline{\text{OE}}$ ) is high.

The SN74ALVC7814 is characterized for operation from 0°C to 70°C.

### logic symbol†

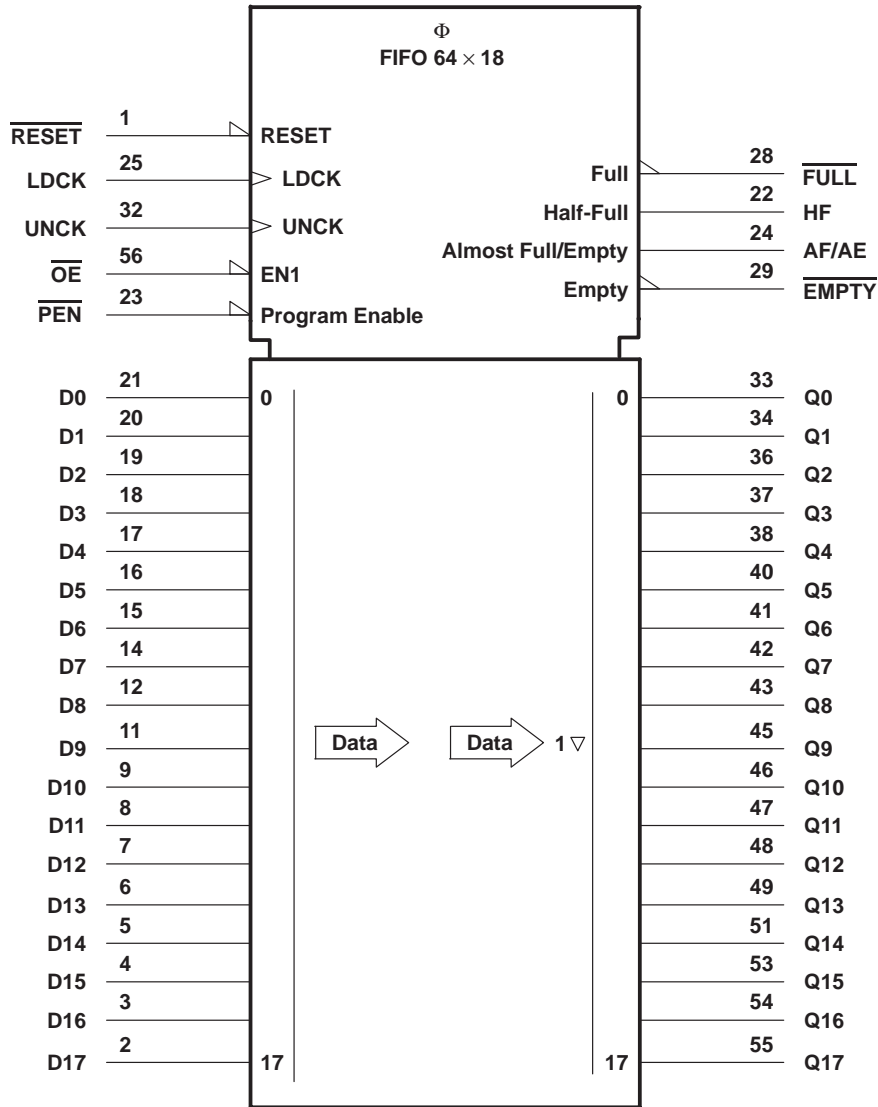

† This symbol is in accordance with ANSI/IEEE Std 91-1984 and IEC Publication 617-12.

## functional block diagram

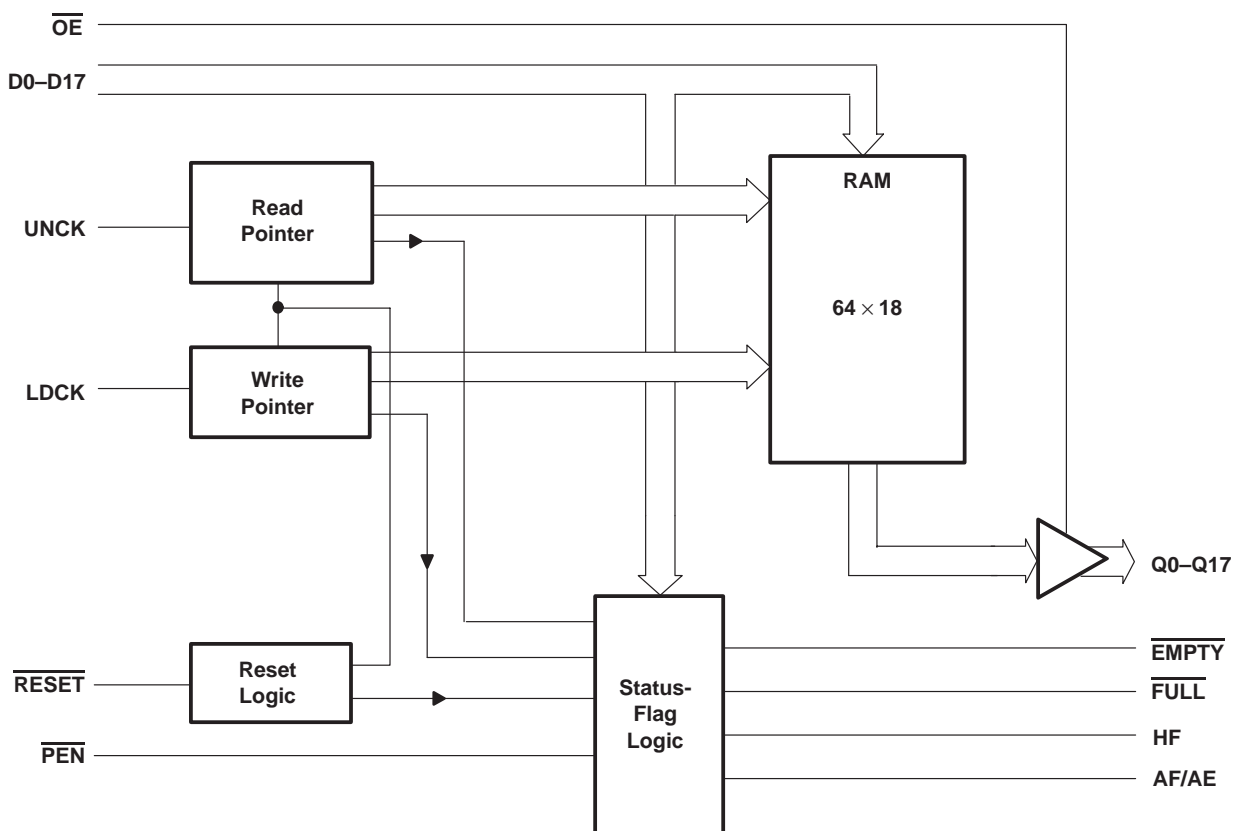

## Terminal Functions

TERMINAL NAME	NO.	I/O	DESCRIPTION
AF/AE	24	O	Almost full/almost empty flag. Depth-offset values can be programmed for this flag or the default value of 64 can be used for both the almost empty offset (X) and the almost full offset (Y). AF/AE is high when memory contains X or fewer words or (64 – Y) or more words. AF/AE is high after reset.
D0–D17	2–9, 11–12, 14–21	I	18-bit data input port
$\overline{\text{EMPTY}}$	29	O	Empty flag. $\overline{\text{EMPTY}}$ is low when the FIFO is empty. A FIFO reset also causes $\overline{\text{EMPTY}}$ to go low.
$\overline{\text{FULL}}$	28	O	Full flag. $\overline{\text{FULL}}$ is low when the FIFO is full. A FIFO reset causes $\overline{\text{FULL}}$ to go high.
HF	22	O	Half-full flag. HF is high when the FIFO memory contains 32 or more words. HF is low after reset.
LDCK	25	I	Load clock. Data is written to the FIFO on the rising edge of LDCK when $\overline{\text{FULL}}$ is high.
$\overline{\text{OE}}$	56	I	Output enable. When $\overline{\text{OE}}$ is high, the data outputs are in the high-impedance state.
$\overline{\text{PEN}}$	23	I	Program enable. After reset and before the first word is written to the FIFO, the binary value on D0–D7 is latched as an AF/AE offset value when $\overline{\text{PEN}}$ is low and WRTCLK is high.
Q0–Q17	33–34, 36–38, 40–43, 45–49, 51, 53–55	O	18-bit data output port
$\overline{\text{RESET}}$	1	I	Reset. A low level on $\overline{\text{RESET}}$ resets the FIFO and drives AF/AE and $\overline{\text{FULL}}$ high and HF and $\overline{\text{EMPTY}}$ low.
UNCK	32	I	Unload clock. Data is read from the FIFO on the rising edge of UNCK when $\overline{\text{EMPTY}}$ is high.

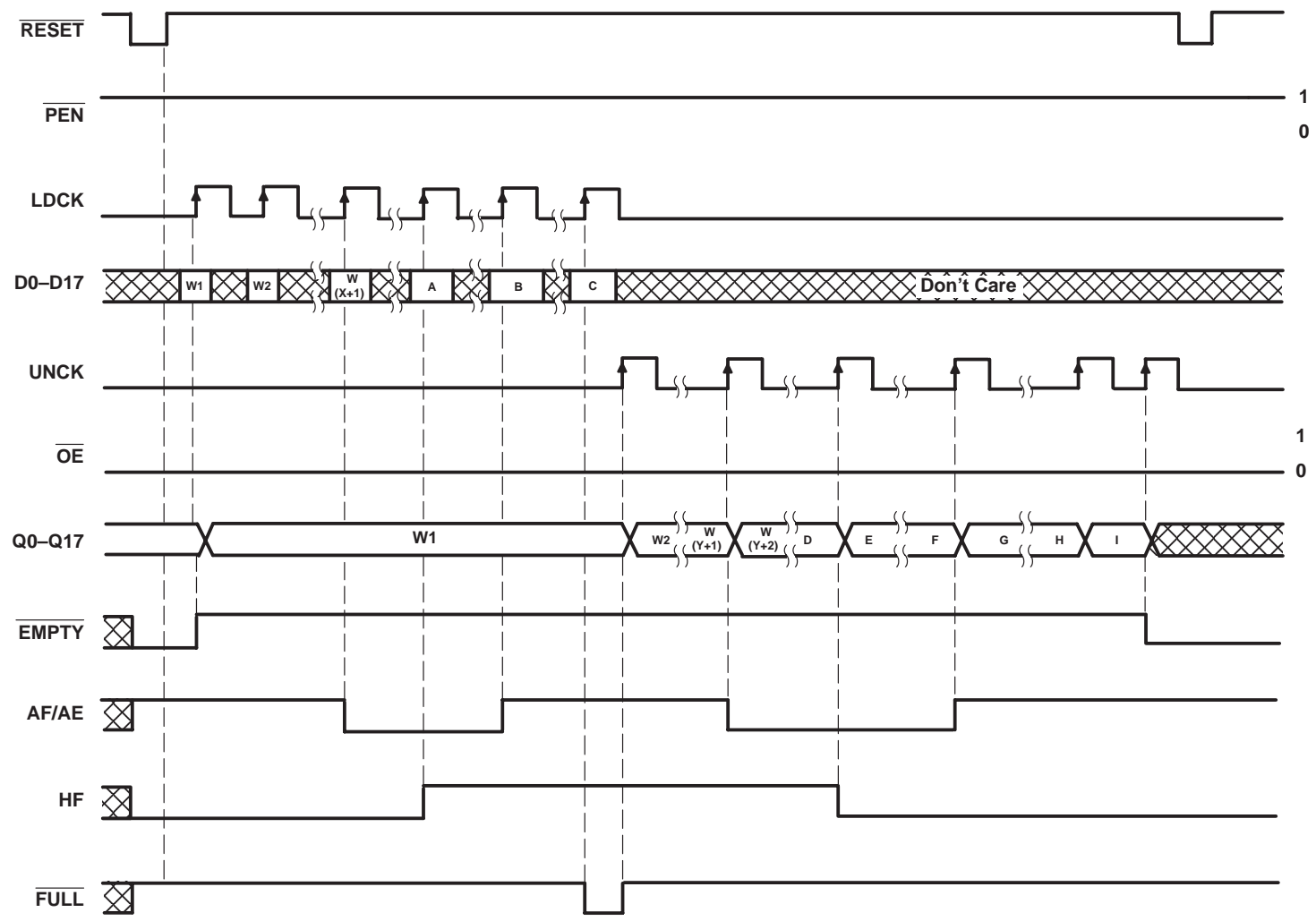

Define the AF/AE Flag Using the Default Value of X and Y

Figure 1. Write, Read, and Flag Timing Reference

DATA-WORD NUMBERS FOR FLAG TRANSITIONS

DEVICE	TRANSITION WORD								
	A	B	C	D	E	F	G	H	I
SN74ALVC7814	W32	W(64 – Y)	W64	W33	W34	W(64 – X)	W(65 – X)	W64	W64

Figure 1. Write, Read, and Flag Timing Reference (Continued)

### offset values for AF/AE

The AF/AE flag has two programmable limits: the almost-empty offset value (X) and the almost-full offset value (Y). They can be programmed after the FIFO is reset and before the first word is written to memory. The AF/AE flag is high when the FIFO contains X or fewer words or (512 – Y) or more words.

To program the offset values,  $\overline{\text{PEN}}$  can be brought low after reset. On the following low-to-high transition of LDCK, the binary value on D0–D7 is stored as the almost-empty offset value (X) and the almost-full offset value (Y). Holding  $\overline{\text{PEN}}$  low for another low-to-high transition of LDCK reprograms Y to the binary value on D0–D7 at the time of the second LDCK low-to-high transition. Writes to the FIFO memory are disabled while the offsets are programmed. A maximum value of 32 can be programmed for either X or Y (see Figure 2). To use the default values of X = Y = 8,  $\overline{\text{PEN}}$  must be held high.

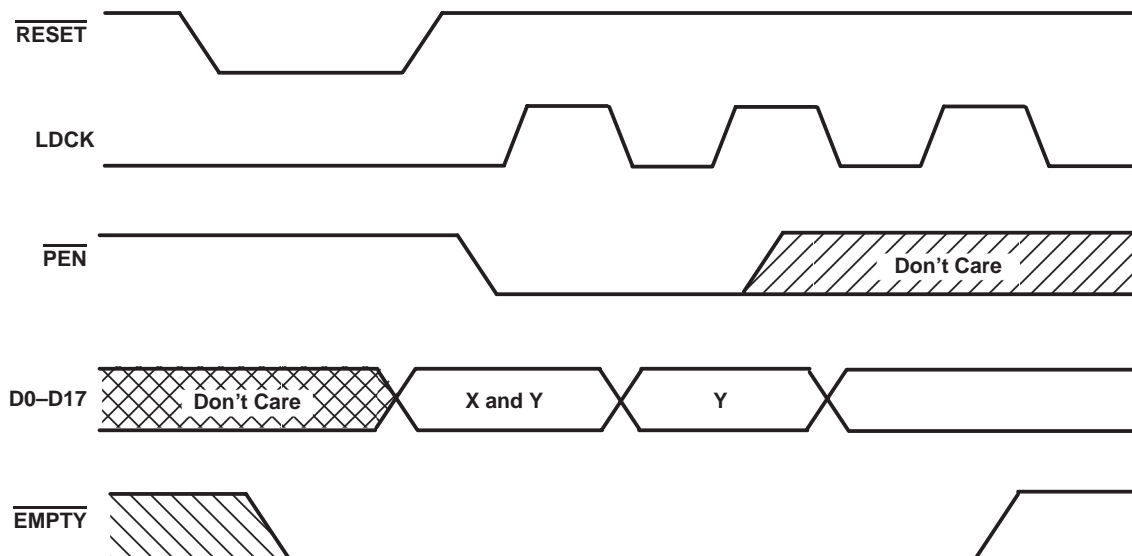

Figure 2. Programming X and Y Separately

**absolute maximum ratings over operating free-air temperature range (unless otherwise noted)†**

Supply voltage range, $V_{CC}$	–0.5 V to 4.6 V
Input voltage range, $V_I$ (see Note 1)	–0.5 V to 4.6 V
Output voltage range, $V_O$ (see Notes 1 and 2)	–0.5 V to $V_{CC} + 0.5$ V
Input clamp current, $I_{IK}$ ( $V_I < 0$ )	–50 mA
Output clamp current, $I_{OK}$ ( $V_O < 0$ or $V_O > V_{CC}$ )	±50 mA
Continuous output current, $I_O$ ( $V_O = 0$ to $V_{CC}$ )	±50 mA
Continuous current through $V_{CC}$ or GND	±100 mA
Voltage applied to a disabled 3-state output	–0.5 V to 3.6 V
Package thermal impedance, $\theta_{JA}$ (see Note 3)	74°C/W
Storage temperature range, $T_{stg}$	–65°C to 150°C

† Stresses beyond those listed under “absolute maximum ratings” may cause permanent damage to the device. These are stress ratings only, and functional operation of the device at these or any other conditions beyond those indicated under “recommended operating conditions” is not implied. Exposure to absolute-maximum-rated conditions for extended periods may affect device reliability.

- NOTES: 1. The input and output voltage ratings can be exceeded if the input and output clamp-current ratings are observed.  
 2. This value is limited to 4.6 V maximum.  
 3. The package thermal impedance is calculated in accordance with JESD 51.

**recommended operating conditions**

		'ALVC7814-25		'ALVC7814-40		UNIT
		MIN	MAX	MIN	MAX	
$V_{CC}$	Supply voltage	3	3.6	3	3.6	V
$V_{IH}$	High-level input voltage	2		2		V
$V_{IL}$	Low-level input voltage		0.8		0.8	V
$V_I$	Input voltage	0	$V_{CC}$	0	$V_{CC}$	V
$V_O$	Output voltage	0	$V_{CC}$	0	$V_{CC}$	V
$I_{OH}$	High-level output current, Q outputs, flags	$V_{CC} = 3$ V		–8	–8	mA
$I_{OL}$	Low-level output current, Q outputs, flags	$V_{CC} = 3$ V		16	16	mA
$T_A$	Operating free-air temperature	0	70	0	70	°C

**electrical characteristics over recommended operating free-air temperature range (unless otherwise noted)**

PARAMETER		TEST CONDITIONS		MIN	TYP‡	MAX	UNIT
$V_{OH}$	Flags, Q outputs	$V_{CC} = 3$ V to 3.6 V,	$I_{OH} = -100$ $\mu$ A	$V_{CC}-0.2$			V
		$V_{CC} = 3$ V,	$I_{OH} = -8$ mA	2.4			
$V_{OL}$	Flags, Q outputs	$V_{CC} = 3$ V to 3.6 V,	$I_{OL} = 100$ $\mu$ A			0.2	V
	Flags	$V_{CC} = 3$ V,	$I_{OL} = 8$ mA			0.4	
	Q outputs	$V_{CC} = 3$ V,	$I_{OL} = 16$ mA			0.55	
$I_I$		$V_{CC} = 3.6$ V,	$V_I = V_{CC}$ or GND			±5	$\mu$ A
$I_{OZ}$		$V_{CC} = 3.6$ V,	$V_O = V_{CC}$ or GND			±10	$\mu$ A
$I_{CC}$		$V_{CC} = 3.6$ V,	$V_I = V_{CC}$ or GND, $I_O = 0$			40	$\mu$ A
$\Delta I_{CC}$ §		$V_{CC} = 3.6$ V, One input at $V_{CC}-0.6$ V, Other inputs at $V_{CC}$ or GND				500	$\mu$ A
$C_i$		$V_{CC} = 3.3$ V,	$V_I = V_{CC}$ or GND			3	pF
$C_o$		$V_{CC} = 3.3$ V,	$V_O = V_{CC}$ or GND			6	pF

‡ All typical values are at  $V_{CC} = 3.3$  V,  $T_A = 25^\circ$ C.

§ This is the supply current for each input that is at one of the specified TTL voltage levels rather than 0 V or  $V_{CC}$ .



## timing requirements over recommended operating conditions (see Figures 1 through 3)

		'ALVC7814-25		'ALVC7814-40		UNIT
		MIN	MAX	MIN	MAX	
$f_{\text{clock}}$	Clock frequency	40		25		MHz
$t_w$	Pulse duration	D0–D17 high or low	8	12	ns	
		LDCK high or low	8	12		
		UNCK high or low	8	12		
		PEN low	8	12		
		RESET low	10	12		
$t_{\text{su}}$	Setup time	D0–D17 before LDCK $\uparrow$	5	5	ns	
		LDCK inactive before $\overline{\text{RESET}}$ high	6	6		
		PEN before LDCK $\uparrow$	8	8		
$t_h$	Hold time	D0–D17 after LDCK $\uparrow$	0	0	ns	
		$\overline{\text{PEN}}$ high after LDCK low	0	0		
		PEN low after LDCK $\uparrow$	3	3		
		LDCK inactive after $\overline{\text{RESET}}$ high	6	6		

switching characteristics over recommended ranges of supply voltage and operating free-air temperature,  $C_L = 50$  pF (unless otherwise noted) (see Figure 3)

PARAMETER	FROM (INPUT)	TO (OUTPUT)	'ALVC7814-25		'ALVC7814-40		UNIT
			MIN	MAX	MIN	MAX	
$f_{\text{max}}$	LDCK or UNCK		40		25		MHz
$t_{\text{pd}}$	LDCK $\uparrow$	Any Q	9	22	9	24	ns
	UNCK $\uparrow$		6	18	6	20	
$t_{\text{PLH}}$	LDCK $\uparrow$	$\overline{\text{EMPTY}}$	6	17	6	19	ns
$t_{\text{PHL}}$	UNCK $\uparrow$	$\overline{\text{EMPTY}}$	6	17	6	19	ns
	$\overline{\text{RESET}}$ low		4	18	4	20	
$t_{\text{PLH}}$	UNCK $\uparrow$	$\overline{\text{FULL}}$	6	17	6	19	ns
	$\overline{\text{RESET}}$ low		4	20	4	22	
$t_{\text{PHL}}$	LDCK $\uparrow$	$\overline{\text{FULL}}$	6	17	6	19	ns
$t_{\text{pd}}$	LDCK $\uparrow$	AF/AE	7	20	7	22	ns
	UNCK $\uparrow$		7	20	7	22	
$t_{\text{PLH}}$	$\overline{\text{RESET}}$ low	AF/AE	2	12	2	14	ns
	LDCK $\uparrow$	HF	5	20	5	22	
$t_{\text{PHL}}$	UNCK $\uparrow$	HF	7	20	7	22	ns
	$\overline{\text{RESET}}$ low		3	14	3	16	
$t_{\text{en}}$	$\overline{\text{OE}}$	Any Q	2	10	2	11	ns
$t_{\text{dis}}$	$\overline{\text{OE}}$	Any Q	2	11	2	12	ns

operating characteristics,  $V_{\text{CC}} = 3.3$  V,  $T_A = 25^\circ\text{C}$ 

PARAMETER		TEST CONDITIONS	TYP	UNIT
$C_{\text{pd}}$	Power dissipation capacitance per FIFO channel	Outputs enabled $C_L = 50$ pF, $f = 5$ MHz	53	pF

PARAMETER MEASUREMENT INFORMATION

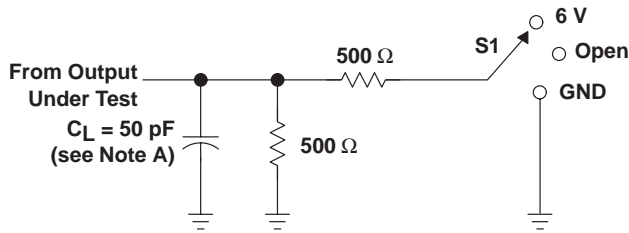

LOAD CIRCUIT FOR OUTPUTS

PARAMETER		S1
$t_{en}$	$t_{PZH}$	GND
	$t_{PZL}$	6 V
$t_{dis}$	$t_{PHZ}$	GND
	$t_{PLZ}$	6 V
$t_{pd}$	$t_{PLH}/t_{PHL}$	Open

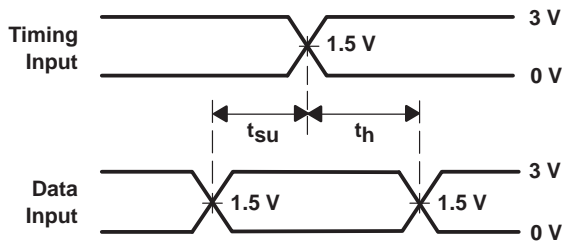

VOLTAGE WAVEFORMS SETUP AND HOLD TIMES

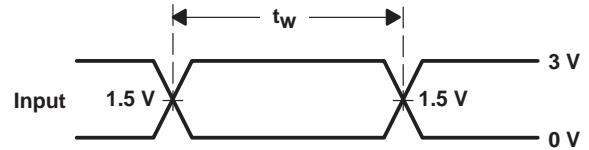

VOLTAGE WAVEFORMS PULSE DURATION

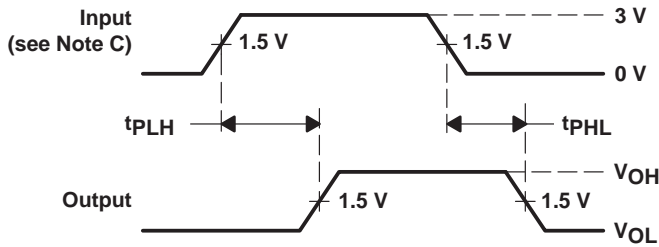

VOLTAGE WAVEFORMS PROPAGATION DELAY TIMES

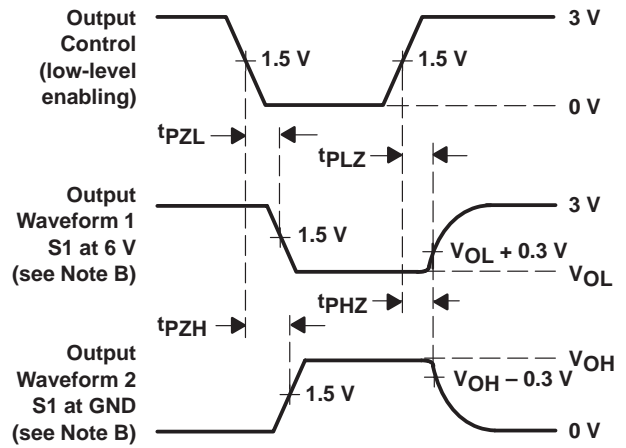

VOLTAGE WAVEFORMS ENABLE AND DISABLE TIMES

- NOTES: A.  $C_L$  includes probe and jig capacitance.  
 B. Waveform 1 is for an output with internal conditions such that the output is low except when disabled by the output control. Waveform 2 is for an output with internal conditions such that the output is high except when disabled by the output control.  
 C. All input pulses are supplied by generators having the following characteristics:  $PRR \leq 10$  MHz,  $Z_O = 50 \Omega$ ,  $t_r \leq 2.5$  ns,  $t_f \leq 2.5$  ns.

Figure 3. Standard CMOS Outputs (FULL, EMPTY, HF, AF/AE)

## TYPICAL CHARACTERISTICS

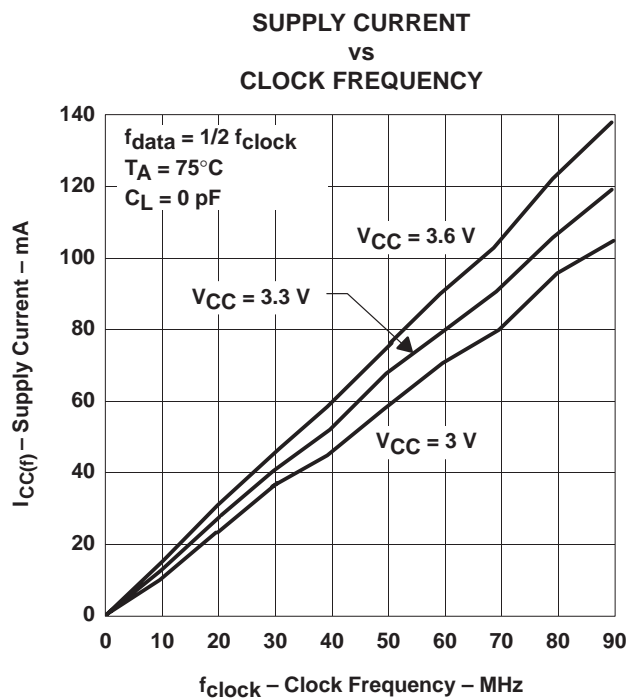

Figure 4

APPLICATION INFORMATION

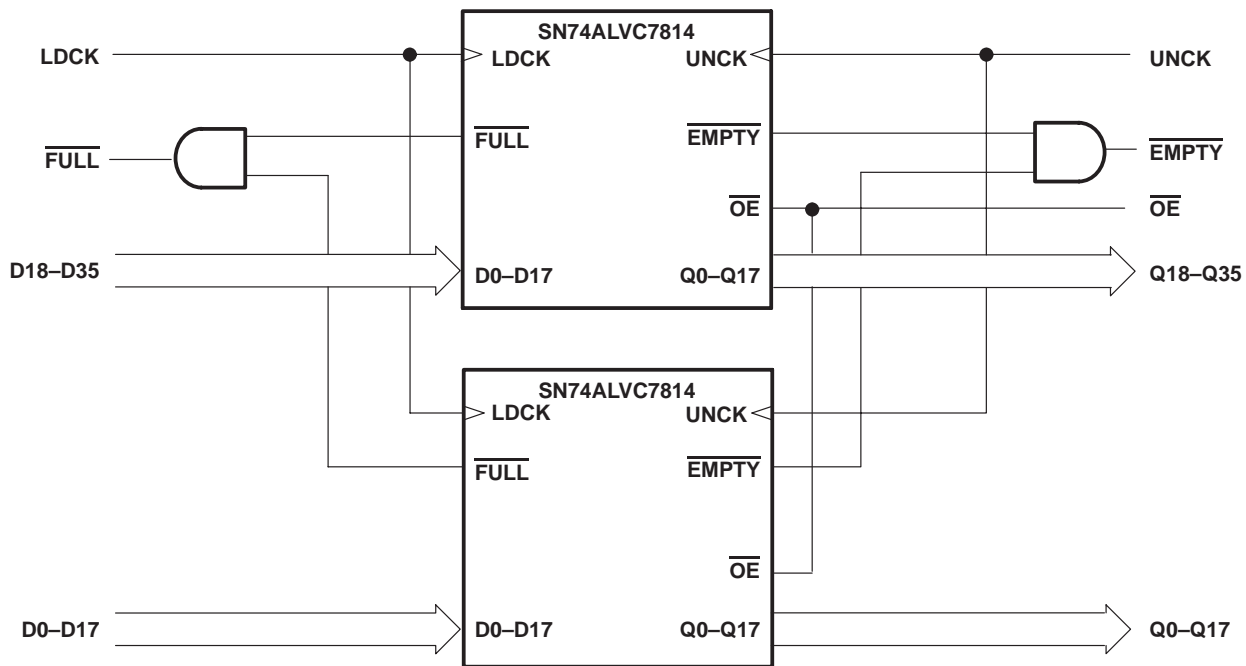

Figure 5. Word-Width Expansion: 64 × 36 Bits

## IMPORTANT NOTICE

Texas Instruments and its subsidiaries (TI) reserve the right to make changes to their products or to discontinue any product or service without notice, and advise customers to obtain the latest version of relevant information to verify, before placing orders, that information being relied on is current and complete. All products are sold subject to the terms and conditions of sale supplied at the time of order acknowledgement, including those pertaining to warranty, patent infringement, and limitation of liability.

TI warrants performance of its semiconductor products to the specifications applicable at the time of sale in accordance with TI's standard warranty. Testing and other quality control techniques are utilized to the extent TI deems necessary to support this warranty. Specific testing of all parameters of each device is not necessarily performed, except those mandated by government requirements.

CERTAIN APPLICATIONS USING SEMICONDUCTOR PRODUCTS MAY INVOLVE POTENTIAL RISKS OF DEATH, PERSONAL INJURY, OR SEVERE PROPERTY OR ENVIRONMENTAL DAMAGE ("CRITICAL APPLICATIONS"). TI SEMICONDUCTOR PRODUCTS ARE NOT DESIGNED, AUTHORIZED, OR WARRANTED TO BE SUITABLE FOR USE IN LIFE-SUPPORT DEVICES OR SYSTEMS OR OTHER CRITICAL APPLICATIONS. INCLUSION OF TI PRODUCTS IN SUCH APPLICATIONS IS UNDERSTOOD TO BE FULLY AT THE CUSTOMER'S RISK.

In order to minimize risks associated with the customer's applications, adequate design and operating safeguards must be provided by the customer to minimize inherent or procedural hazards.

TI assumes no liability for applications assistance or customer product design. TI does not warrant or represent that any license, either express or implied, is granted under any patent right, copyright, mask work right, or other intellectual property right of TI covering or relating to any combination, machine, or process in which such semiconductor products or services might be or are used. TI's publication of information regarding any third party's products or services does not constitute TI's approval, warranty or endorsement thereof.