

# SN54AS867, SN54AS869 SN74ALS867A, SN74ALS869, SN74AS867, SN74AS869 SYNCHRONOUS 8-BIT UP/DOWN COUNTERS

SDAS115C – DECEMBER 1982 – REVISED JANUARY 1995

- Fully Programmable With Synchronous Counting and Loading
- SN74ALS867A and 'AS867 Have Asynchronous Clear; SN74ALS869 and 'AS869 Have Synchronous Clear
- Fully Independent Clock Circuit Simplifies Use
- Ripple-Carry Output for n-Bit Cascading
- Package Options Include Plastic Small-Outline (DW) Packages, Ceramic Chip Carriers (FK), and Standard Plastic (NT) and Ceramic (JT) 300-mil DIPs

## description

These synchronous, presettable, 8-bit up/down counters feature internal-carry look-ahead circuitry for cascading in high-speed counting applications. Synchronous operation is provided by having all flip-flops clocked simultaneously so that the outputs change coincidentally with each other when so instructed by the count-enable ( $\overline{\text{ENP}}$ ,  $\overline{\text{ENT}}$ ) inputs and internal gating. This mode of operation eliminates the output counting spikes normally associated with asynchronous (ripple-clock) counters. A buffered clock (CLK) input triggers the eight flip-flops on the rising (positive-going) edge of the clock waveform.

These counters are fully programmable; they may be preset to any number between 0 and 255. The load-input circuitry allows parallel loading of the cascaded counters. Because loading is synchronous, selecting the load mode disables the counter and causes the outputs to agree with the data inputs after the next clock pulse.

The carry look-ahead circuitry provides for cascading counters for n-bit synchronous applications without additional gating. Two count-enable ( $\overline{\text{ENP}}$  and  $\overline{\text{ENT}}$ ) inputs and a ripple-carry ( $\overline{\text{RCO}}$ ) output are instrumental in accomplishing this function. Both  $\overline{\text{ENP}}$  and  $\overline{\text{ENT}}$  must be low to count. The direction of the count is determined by the levels of the select (S0, S1) inputs as shown in the function table.  $\overline{\text{ENT}}$  is fed forward to enable  $\overline{\text{RCO}}$ .  $\overline{\text{RCO}}$  thus enabled produces a low-level pulse while the count is zero (all outputs low) counting down or 255 counting up (all outputs high). This low-level overflow-carry pulse can be used to enable successive cascaded stages. Transitions at  $\overline{\text{ENP}}$  and  $\overline{\text{ENT}}$  are allowed regardless of the level of CLK. All inputs are diode clamped to minimize transmission-line effects, thereby simplifying system design.

These counters feature a fully independent clock circuit. With the exception of the asynchronous clear on the SN74ALS867A and 'AS867, changes at S0 and S1 that modify the operating mode have no effect on the Q outputs until clocking occurs. For the 'AS867 and 'AS869, any time  $\overline{\text{ENP}}$  and/or  $\overline{\text{ENT}}$  is taken high,  $\overline{\text{RCO}}$  either goes or remains high. For the SN74ALS867A and SN74ALS869, any time  $\overline{\text{ENT}}$  is taken high,  $\overline{\text{RCO}}$  either goes or remains high. The function of the counter (whether enabled, disabled, loading, or counting) is dictated solely by the conditions meeting the stable setup and hold times.

SN54AS867, SN54AS869 . . . JT PACKAGE  
SN74ALS867A, SN74ALS869, SN74AS867,  
SN74AS869 . . . DW OR NT PACKAGE  
(TOP VIEW)

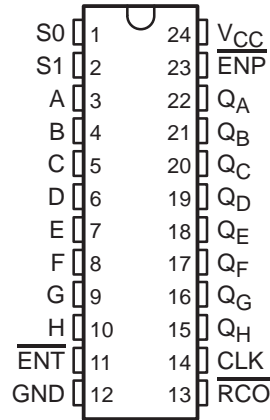

SN54AS867, SN54AS869 . . . FK PACKAGE  
(TOP VIEW)

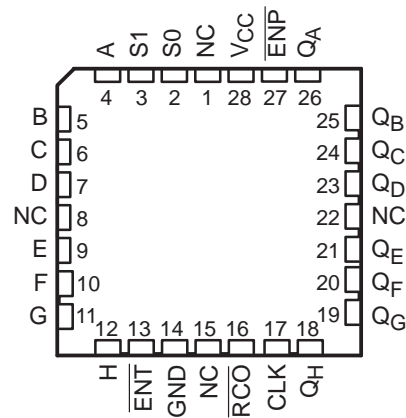

NC – No internal connection

**PACKAGING INFORMATION**

Orderable Device	Status <sup>(1)</sup>	Package Type	Package Drawing	Pins	Package Qty	Eco Plan <sup>(2)</sup>	Lead/Ball Finish	MSL Peak Temp <sup>(3)</sup>
5962-89526013A	ACTIVE	LCCC	FK	28	1	TBD	Call TI	Level-NC-NC-NC
5962-8952601KA	ACTIVE	CFP	W	24	1	TBD	Call TI	Level-NC-NC-NC
5962-8952601LA	ACTIVE	CDIP	JT	24	1	TBD	Call TI	Level-NC-NC-NC
5962-89668013A	ACTIVE	LCCC	FK	28	1	TBD	Call TI	Level-NC-NC-NC
5962-8966801KA	ACTIVE	CFP	W	24	1	TBD	Call TI	Level-NC-NC-NC
5962-8966801LA	ACTIVE	CDIP	JT	24	1	TBD	Call TI	Level-NC-NC-NC
SN54AS867JT	ACTIVE	CDIP	JT	24	1	TBD	Call TI	Level-NC-NC-NC
SN54AS869JT	ACTIVE	CDIP	JT	24	1	TBD	Call TI	Level-NC-NC-NC
SN74ALS867ADW	ACTIVE	SOIC	DW	24	25	Green (RoHS & no Sb/Br)	CU NIPDAU	Level-1-260C-UNLIM
SN74ALS867ADWE4	ACTIVE	SOIC	DW	24	25	Green (RoHS & no Sb/Br)	CU NIPDAU	Level-1-260C-UNLIM
SN74ALS867ADWR	ACTIVE	SOIC	DW	24	2000	Green (RoHS & no Sb/Br)	CU NIPDAU	Level-1-260C-UNLIM
SN74ALS867ADWRE4	ACTIVE	SOIC	DW	24	2000	Green (RoHS & no Sb/Br)	CU NIPDAU	Level-1-260C-UNLIM
SN74ALS867ANT	ACTIVE	PDIP	NT	24	15	Pb-Free (RoHS)	CU NIPDAU	Level-NC-NC-NC
SN74ALS867ANTE4	ACTIVE	PDIP	NT	24	15	Pb-Free (RoHS)	CU NIPDAU	Level-NC-NC-NC
SN74ALS869DW	ACTIVE	SOIC	DW	24	25	Green (RoHS & no Sb/Br)	CU NIPDAU	Level-1-260C-UNLIM
SN74ALS869DWE4	ACTIVE	SOIC	DW	24	25	Green (RoHS & no Sb/Br)	CU NIPDAU	Level-1-260C-UNLIM
SN74ALS869DWR	ACTIVE	SOIC	DW	24	2000	Green (RoHS & no Sb/Br)	CU NIPDAU	Level-1-260C-UNLIM
SN74ALS869DWRE4	ACTIVE	SOIC	DW	24	2000	Green (RoHS & no Sb/Br)	CU NIPDAU	Level-1-260C-UNLIM
SN74ALS869NT	ACTIVE	PDIP	NT	24	15	Pb-Free (RoHS)	CU NIPDAU	Level-NC-NC-NC
SN74ALS869NTE4	ACTIVE	PDIP	NT	24	15	Pb-Free (RoHS)	CU NIPDAU	Level-NC-NC-NC
SN74AS867DW	ACTIVE	SOIC	DW	24	25	Green (RoHS & no Sb/Br)	CU NIPDAU	Level-1-260C-UNLIM
SN74AS867DWE4	ACTIVE	SOIC	DW	24	25	Green (RoHS & no Sb/Br)	CU NIPDAU	Level-1-260C-UNLIM
SN74AS867DWR	ACTIVE	SOIC	DW	24	2000	Green (RoHS & no Sb/Br)	CU NIPDAU	Level-1-260C-UNLIM
SN74AS867DWRE4	ACTIVE	SOIC	DW	24	2000	Green (RoHS & no Sb/Br)	CU NIPDAU	Level-1-260C-UNLIM
SN74AS867NT	ACTIVE	PDIP	NT	24	15	Pb-Free (RoHS)	CU NIPDAU	Level-NC-NC-NC
SN74AS867NT3	OBSOLETE	PDIP	NT	24		TBD	Call TI	Call TI
SN74AS867NTE4	ACTIVE	PDIP	NT	24	15	Pb-Free (RoHS)	CU NIPDAU	Level-NC-NC-NC
SN74AS869DW	ACTIVE	SOIC	DW	24	25	Green (RoHS & no Sb/Br)	CU NIPDAU	Level-1-260C-UNLIM
SN74AS869DWE4	ACTIVE	SOIC	DW	24	25	Green (RoHS & no Sb/Br)	CU NIPDAU	Level-1-260C-UNLIM

Orderable Device	Status <sup>(1)</sup>	Package Type	Package Drawing	Pins	Package Qty	Eco Plan <sup>(2)</sup>	Lead/Ball Finish	MSL Peak Temp <sup>(3)</sup>
						no Sb/Br)		
SN74AS869DWR	ACTIVE	SOIC	DW	24	2000	Green (RoHS & no Sb/Br)	CU NIPDAU	Level-1-260C-UNLIM
SN74AS869DWRE4	ACTIVE	SOIC	DW	24	2000	Green (RoHS & no Sb/Br)	CU NIPDAU	Level-1-260C-UNLIM
SN74AS869NT	ACTIVE	PDIP	NT	24	15	Pb-Free (RoHS)	CU NIPDAU	Level-NC-NC-NC
SN74AS869NT3	OBSOLETE	PDIP	NT	24		TBD	Call TI	Call TI
SN74AS869NTE4	ACTIVE	PDIP	NT	24	15	Pb-Free (RoHS)	CU NIPDAU	Level-NC-NC-NC
SNJ54AS867FK	ACTIVE	LCCC	FK	28	1	TBD	Call TI	Level-NC-NC-NC
SNJ54AS867JT	ACTIVE	CDIP	JT	24	1	TBD	Call TI	Level-NC-NC-NC
SNJ54AS867W	ACTIVE	CFP	W	24	1	TBD	Call TI	Level-NC-NC-NC
SNJ54AS869FK	ACTIVE	LCCC	FK	28	1	TBD	Call TI	Level-NC-NC-NC
SNJ54AS869JT	ACTIVE	CDIP	JT	24	1	TBD	Call TI	Level-NC-NC-NC
SNJ54AS869W	ACTIVE	CFP	W	24	1	TBD	Call TI	Level-NC-NC-NC

<sup>(1)</sup> The marketing status values are defined as follows:

**ACTIVE:** Product device recommended for new designs.

**LIFEBUY:** TI has announced that the device will be discontinued, and a lifetime-buy period is in effect.

**NRND:** Not recommended for new designs. Device is in production to support existing customers, but TI does not recommend using this part in a new design.

**PREVIEW:** Device has been announced but is not in production. Samples may or may not be available.

**OBSOLETE:** TI has discontinued the production of the device.

<sup>(2)</sup> Eco Plan - The planned eco-friendly classification: Pb-Free (RoHS) or Green (RoHS & no Sb/Br) - please check <http://www.ti.com/productcontent> for the latest availability information and additional product content details.

**TBD:** The Pb-Free/Green conversion plan has not been defined.

**Pb-Free (RoHS):** TI's terms "Lead-Free" or "Pb-Free" mean semiconductor products that are compatible with the current RoHS requirements for all 6 substances, including the requirement that lead not exceed 0.1% by weight in homogeneous materials. Where designed to be soldered at high temperatures, TI Pb-Free products are suitable for use in specified lead-free processes.

**Green (RoHS & no Sb/Br):** TI defines "Green" to mean Pb-Free (RoHS compatible), and free of Bromine (Br) and Antimony (Sb) based flame retardants (Br or Sb do not exceed 0.1% by weight in homogeneous material)

<sup>(3)</sup> MSL, Peak Temp. -- The Moisture Sensitivity Level rating according to the JEDEC industry standard classifications, and peak solder temperature.

**Important Information and Disclaimer:**The information provided on this page represents TI's knowledge and belief as of the date that it is provided. TI bases its knowledge and belief on information provided by third parties, and makes no representation or warranty as to the accuracy of such information. Efforts are underway to better integrate information from third parties. TI has taken and continues to take reasonable steps to provide representative and accurate information but may not have conducted destructive testing or chemical analysis on incoming materials and chemicals. TI and TI suppliers consider certain information to be proprietary, and thus CAS numbers and other limited information may not be available for release.

In no event shall TI's liability arising out of such information exceed the total purchase price of the TI part(s) at issue in this document sold by TI to Customer on an annual basis.