

# SN74ALS679 12-BIT ADDRESS COMPARATOR

SDAS003C – JUNE 1982 – REVISED JANUARY 1995

- 12-Bit Address Comparator With Enable
- Package Options Include Plastic Small-Outline (DW) Packages and Standard Plastic (N) 300-mil DIPs

DW OR N PACKAGE  
(TOP VIEW)

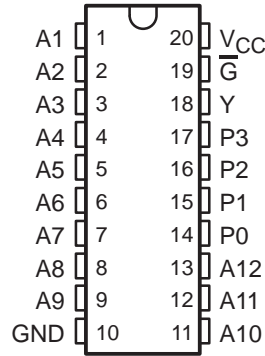

## description

This 12-bit address comparator simplifies addressing of memory boards and/or other peripheral devices. The four P inputs are normally hardwired with a preprogrammed address. An internal decoder determines what input information applied to the A inputs must be low or high to cause a low state at the Y output. For example, a positive-logic bit combination of 0111 (decimal 7) at the P input determines that inputs A1 through A7 must be low and that inputs A8 through A12 must be high to cause the output to go low. Equality of the address applied at the A inputs to the preprogrammed address is indicated by the output being low.

This device features an enable ( $\overline{G}$ ) input. When  $\overline{G}$  is low, the device is enabled. When  $\overline{G}$  is high, the device is disabled and the output is high, regardless of the A and P inputs.

The SN74ALS679 is characterized for operation from 0°C to 70°C.

FUNCTION TABLE

INPUTS																OUTPUT Y	
$\overline{G}$	P3	P2	P1	P0	A1	A2	A3	A4	A5	A6	A7	A8	A9	A10	A11		A12
L	L	L	L	L	H	H	H	H	H	H	H	H	H	H	H	H	L
L	L	L	L	H	L	H	H	H	H	H	H	H	H	H	H	H	L
L	L	L	H	L	L	L	H	H	H	H	H	H	H	H	H	H	L
L	L	L	H	H	L	L	L	H	H	H	H	H	H	H	H	H	L
L	L	H	L	L	L	L	L	H	H	H	H	H	H	H	H	H	L
L	L	H	L	H	L	L	L	L	H	H	H	H	H	H	H	H	L
L	L	H	H	L	L	L	L	L	L	L	L	L	H	H	H	L	L†
L	L	H	H	H	L	L	L	L	L	L	L	L	L	H	H	L	L†
L	L	H	H	H	L	L	L	L	L	L	L	L	L	L	H	L	L†
L	H	H	H	H	L	L	L	L	L	L	L	L	L	L	L	L	L
L	All other combinations															H	
H	Any combination															H	

† The three shaded rows of the function table show combinations that would normally not be used in address comparator applications. The logic symbols above are not valid for these combinations in which P = 12, 13, and 14. If symbols valid for all combinations are required, starting with the fourth exclusive-OR from the bottom, change P ≥ 9 to P = 9 . . . 11/13 . . . 15, P ≥ 10 to P = 10/11/14/15, and P ≥ 11 to P = 11/15.

# SN74ALS679 12-BIT ADDRESS COMPARATOR

SDAS003C – JUNE 1982 – REVISED JANUARY 1995

logic symbol†

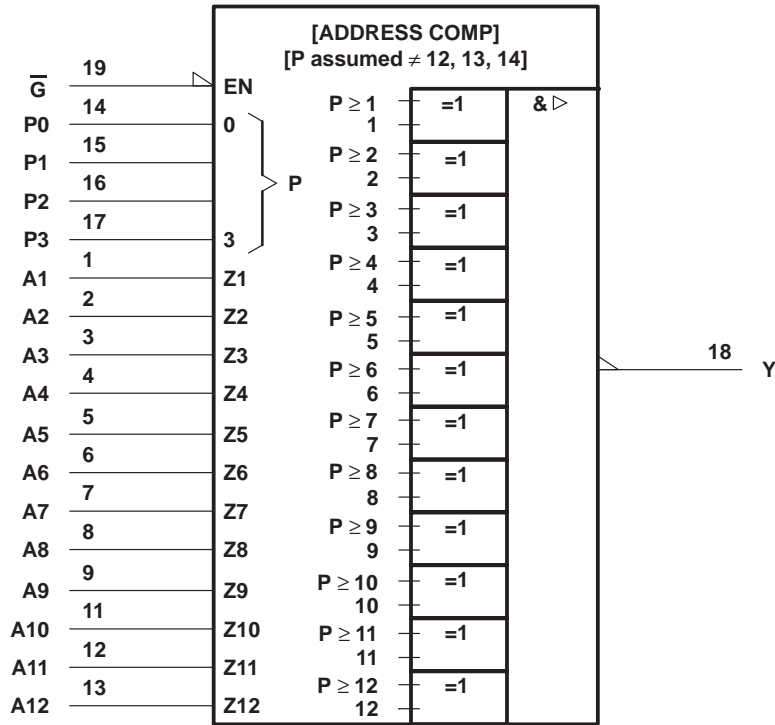

† This symbol is in accordance with ANSI/IEEE Std 91-1984 and IEC Publication 617-12.

logic diagram (positive logic)

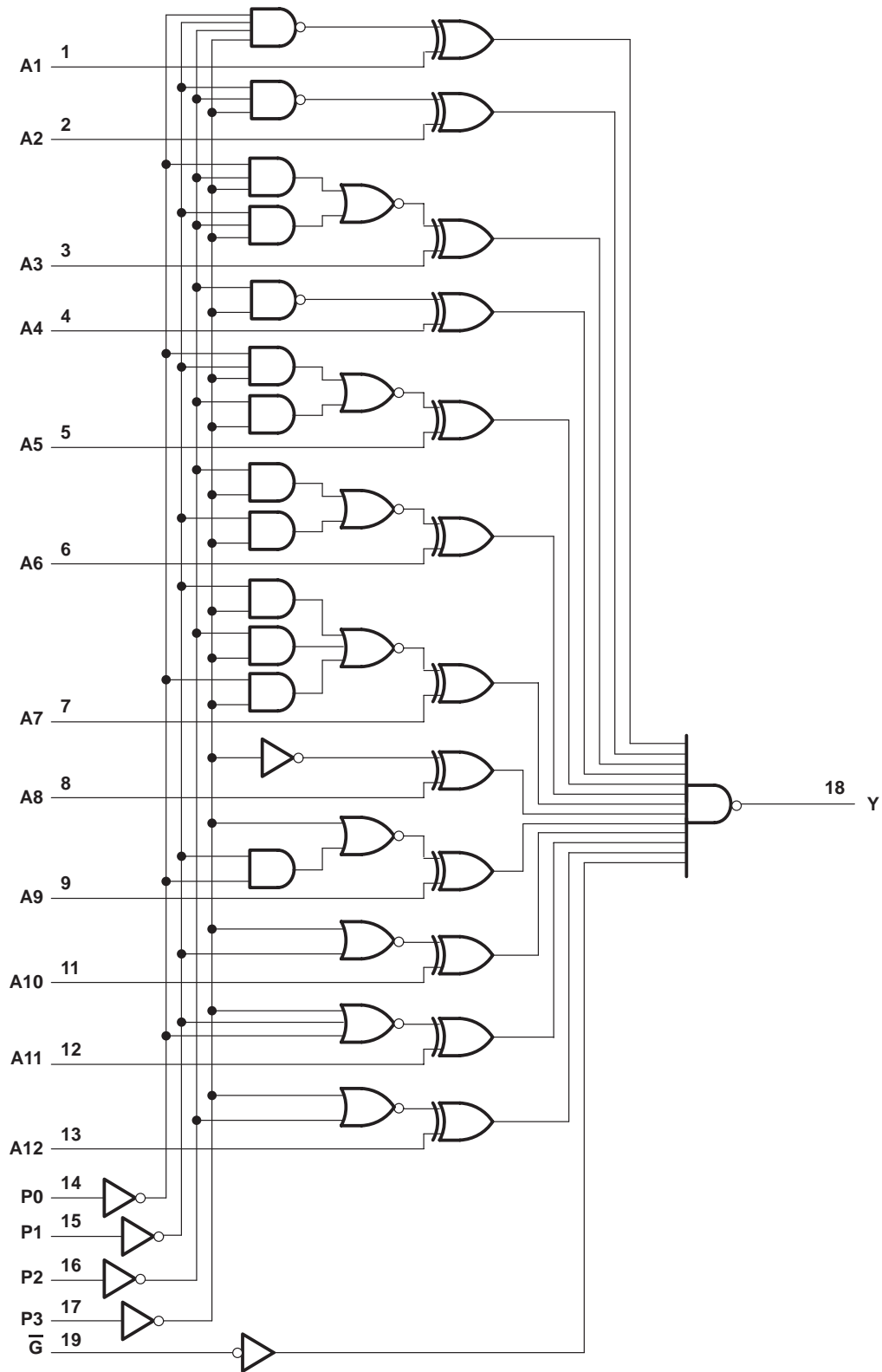

# SN74ALS679

## 12-BIT ADDRESS COMPARATOR

SDAS003C – JUNE 1982 – REVISED JANUARY 1995

### absolute maximum ratings over operating free-air temperature range (unless otherwise noted)†

Supply voltage, $V_{CC}$	7 V
Input voltage, $V_I$	7 V
Operating free-air temperature range, $T_A$	0°C to 70°C
Storage temperature range	-65°C to 150°C

† Stresses beyond those listed under “absolute maximum ratings” may cause permanent damage to the device. These are stress ratings only, and functional operation of the device at these or any other conditions beyond those indicated under “recommended operating conditions” is not implied. Exposure to absolute-maximum-rated conditions for extended periods may affect device reliability.

### recommended operating conditions

	MIN	NOM	MAX	UNIT
$V_{CC}$ Supply voltage	4.5	5	5.5	V
$V_{IH}$ High-level input voltage	2			V
$V_{IL}$ Low-level input voltage			0.8	V
$I_{OH}$ High-level output current			-2.6	mA
$I_{OL}$ Low-level output current			24	mA
$T_A$ Operating free-air temperature	0		70	°C

### electrical characteristics over recommended operating free-air temperature range (unless otherwise noted)

PARAMETER	TEST CONDITIONS	MIN	TYP‡	MAX	UNIT
$V_{IK}$	$V_{CC} = 4.5 V$ , $I_I = -18 mA$			-1.5	V
$V_{OH}$	$V_{CC} = 4.5 V$ to 5.5 V, $I_{OH} = -0.4 mA$	$V_{CC} - 2$			V
	$V_{CC} = 4.5 V$ , $I_{OH} = -2.6 mA$	2.4	3.2		
$V_{OL}$	$V_{CC} = 4.5 V$		0.25	0.4	V
		$I_{OL} = 12 mA$			
			0.35	0.5	
$I_I$	$V_{CC} = 5.5 V$ , $V_I = 7 V$			0.1	mA
$I_{IH}$	$V_{CC} = 5.5 V$ , $V_I = 2.7 V$			20	μA
$I_{IL}$	$V_{CC} = 5.5 V$ , $V_I = 0.4 V$			-0.1	mA
$I_{O§}$	$V_{CC} = 5.5 V$ , $V_O = 2.25 V$	-30		-112	mA
$I_{CC}$	$V_{CC} = 5.5 V$		17	28	mA

‡ All typical values are at  $V_{CC} = 5 V$ ,  $T_A = 25°C$ .

§ The output conditions have been chosen to produce a current that closely approximates one half of the true short-circuit output current,  $I_{OS}$ .

### switching characteristics (see Figure 2)

PARAMETER	FROM (INPUT)	TO (OUTPUT)	$V_{CC} = 4.5 V$ to 5.5 V, $C_L = 50 pF$ , $R_L = 500 \Omega$ , $T_A = MIN$ to $MAX$ ¶		UNIT
			MIN	MAX	
$t_{PLH}$	Any P	Y	4	25	ns
$t_{PHL}$			8	35	
$t_{PLH}$	Any A	Y	5	22	ns
$t_{PHL}$			5	30	
$t_{PLH}$	$\bar{G}$	Y	3	13	ns
$t_{PHL}$			5	25	

¶ For conditions shown as MIN or MAX, use the appropriate value specified under recommended operating conditions.



APPLICATION INFORMATION

The SN74ALS679 can be wired to recognize any one of  $2^{12}$  addresses. The number of lows in the address determines the input pattern for the P inputs. The system address lines that are low in the address to be recognized are connected to the lowest-numbered A inputs of the address comparator. The system address lines that are high are connected to the highest-numbered A inputs.

For example, assume the comparator is to enable a device when the 12-bit system address is:

A11	A10	A9	A8	A7	A6	A5	A4	A3	A2	A1	A0
H	H	L	L	H	H	L	L	H	H	H	H

Because the address contains four lows and eight highs, the following connections are made:

- P3 to 0 V, P2 to  $V_{CC}$ , P1 to 0 V, and P0 to 0 V
- System address lines A9, A8, A5, and A4 to comparator inputs A1 through A4 in any convenient order
- The remaining eight system address lines to comparator inputs A5 through A12 in any convenient order

The output provides an active-low enabling signal.

Figure 1 is a register-bank decoder that examines the 14 most significant bits (A0 through A13) of a 20-bit address to select banks corresponding to the hex addresses 10000, 10040, 10080, and 100C0.

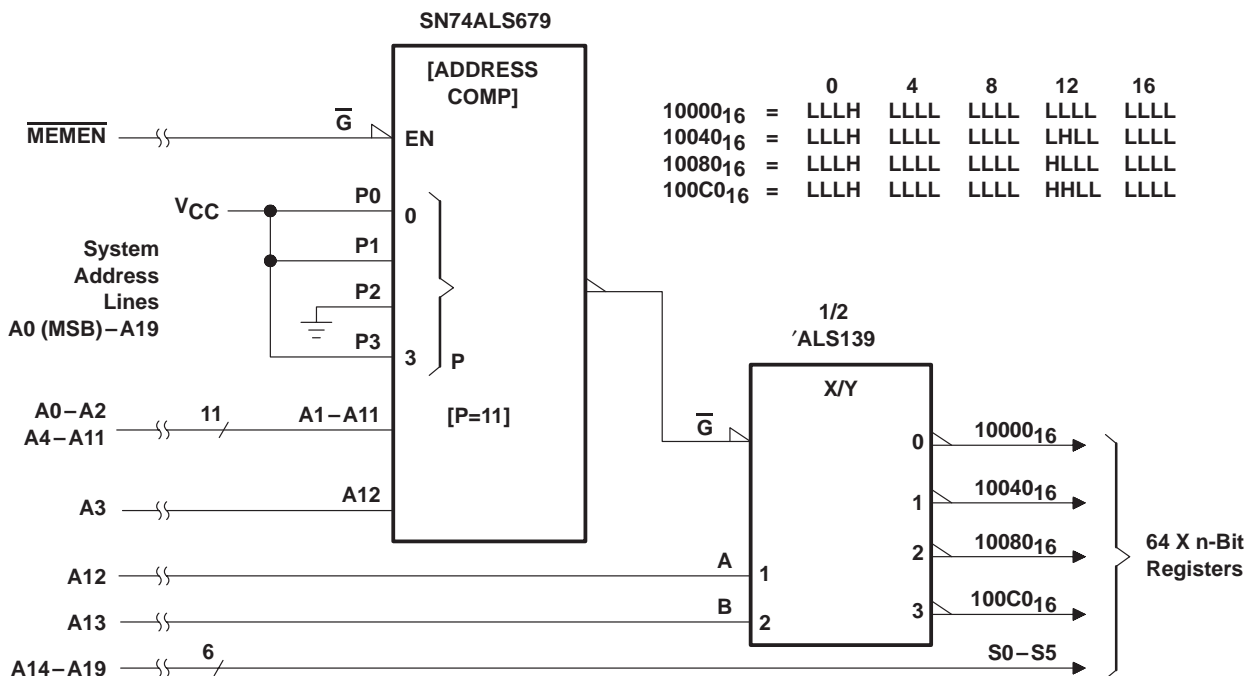
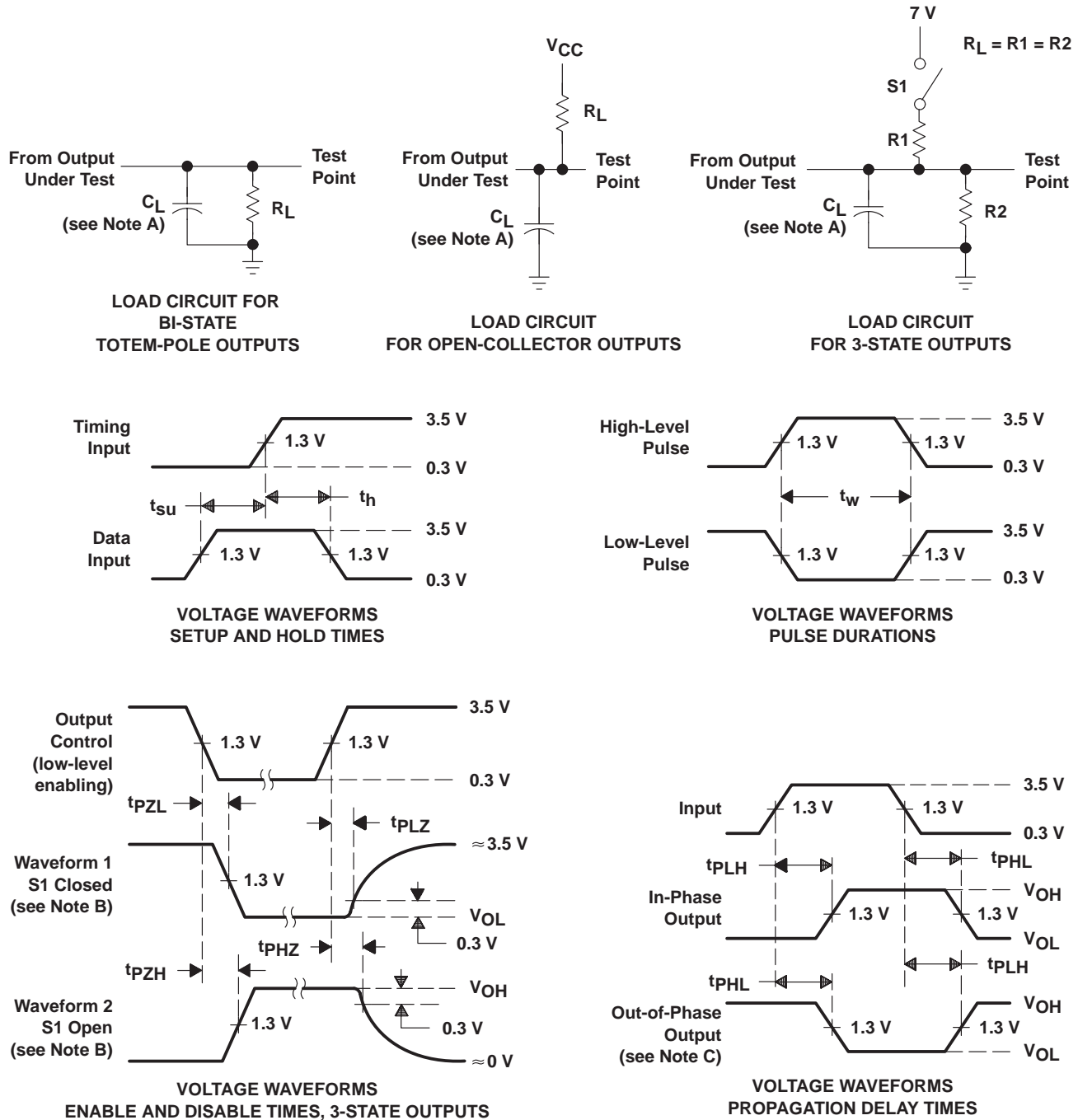

Figure 1. Register-Bank Decoder

# SN74ALS679 12-BIT ADDRESS COMPARATOR

SDAS003C – JUNE 1982 – REVISED JANUARY 1995

## PARAMETER MEASUREMENT INFORMATION SERIES 54ALS/74ALS AND 54AS/74AS DEVICES



- NOTES: A.  $C_L$  includes probe and jig capacitance.  
 B. Waveform 1 is for an output with internal conditions such that the output is low except when disabled by the output control. Waveform 2 is for an output with internal conditions such that the output is high except when disabled by the output control.  
 C. When measuring propagation delay items of 3-state outputs, switch S1 is open.  
 D. All input pulses have the following characteristics:  $PRR \leq 1$  MHz,  $t_r = t_f = 2$  ns, duty cycle = 50%.  
 E. The outputs are measured one at a time with one transition per measurement.

Figure 2. Load Circuits and Voltage Waveforms

## IMPORTANT NOTICE

Texas Instruments and its subsidiaries (TI) reserve the right to make changes to their products or to discontinue any product or service without notice, and advise customers to obtain the latest version of relevant information to verify, before placing orders, that information being relied on is current and complete. All products are sold subject to the terms and conditions of sale supplied at the time of order acknowledgement, including those pertaining to warranty, patent infringement, and limitation of liability.

TI warrants performance of its semiconductor products to the specifications applicable at the time of sale in accordance with TI's standard warranty. Testing and other quality control techniques are utilized to the extent TI deems necessary to support this warranty. Specific testing of all parameters of each device is not necessarily performed, except those mandated by government requirements.

CERTAIN APPLICATIONS USING SEMICONDUCTOR PRODUCTS MAY INVOLVE POTENTIAL RISKS OF DEATH, PERSONAL INJURY, OR SEVERE PROPERTY OR ENVIRONMENTAL DAMAGE ("CRITICAL APPLICATIONS"). TI SEMICONDUCTOR PRODUCTS ARE NOT DESIGNED, AUTHORIZED, OR WARRANTED TO BE SUITABLE FOR USE IN LIFE-SUPPORT DEVICES OR SYSTEMS OR OTHER CRITICAL APPLICATIONS. INCLUSION OF TI PRODUCTS IN SUCH APPLICATIONS IS UNDERSTOOD TO BE FULLY AT THE CUSTOMER'S RISK.

In order to minimize risks associated with the customer's applications, adequate design and operating safeguards must be provided by the customer to minimize inherent or procedural hazards.

TI assumes no liability for applications assistance or customer product design. TI does not warrant or represent that any license, either express or implied, is granted under any patent right, copyright, mask work right, or other intellectual property right of TI covering or relating to any combination, machine, or process in which such semiconductor products or services might be or are used. TI's publication of information regarding any third party's products or services does not constitute TI's approval, warranty or endorsement thereof.