

Distributed by:

JAMECO[®]
ELECTRONICS

www.Jameco.com ♦ 1-800-831-4242

The content and copyrights of the attached
material are the property of its owner.

Jameco Part Number 1500883

SN74ALS666, SN74ALS667 8-BIT D-TYPE TRANSPARENT READ-BACK LATCHES WITH 3-STATE OUTPUTS

SDAS227A – JUNE 1984 – REVISED JANUARY 1995

- 3-State I/O-Type Read-Back Inputs
- Bus-Structured Pinout
- Choice of True or Inverting Logic
 - SN74ALS666 . . . True Outputs
 - SN74ALS667 . . . Inverted Outputs
- Preset and Clear Inputs
- Package Options Include Plastic Small-Outline (DW) Packages and Standard Plastic (NT) 300-mil DIPs

description

These 8-bit D-type transparent latches are designed specifically for storing the contents of the input data bus, plus reading back the stored data onto the input data bus. In addition, they provide a 3-state buffer-type output and are easily utilized in bus-structured applications.

While the latch enable (LE) is high, the Q outputs of the SN74ALS666 follow the data (D) inputs. The \overline{Q} outputs of the SN74ALS667 provide the inverse of the data applied to its D inputs. The Q or \overline{Q} output of both devices is in the high-impedance state if either output-enable ($\overline{OE1}$ or $\overline{OE2}$) input is at a high logic level.

Read back is provided through the read-back control (\overline{OERB}) input. When \overline{OERB} is taken low, the data present at the output of the data latches passes back onto the input data bus. When \overline{OERB} is taken high, the output of the data latches is isolated from the D inputs. \overline{OERB} does not affect the internal operation of the latches; however, caution should be exercised to avoid a bus conflict.

The SN74ALS666 and SN74ALS667 are characterized for operation from 0°C to 70°C.

SN74ALS666 . . . DW OR NT PACKAGE
(TOP VIEW)

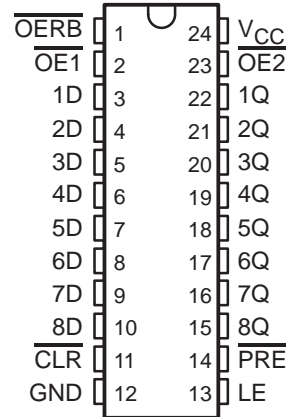

SN74ALS667 . . . DW OR NT PACKAGE
(TOP VIEW)

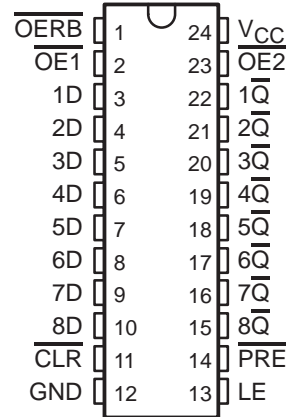

SN74ALS666, SN74ALS667 8-BIT D-TYPE TRANSPARENT READ-BACK LATCHES WITH 3-STATE OUTPUTS

SDAS227A – JUNE 1984 – REVISED JANUARY 1995

logic symbols†

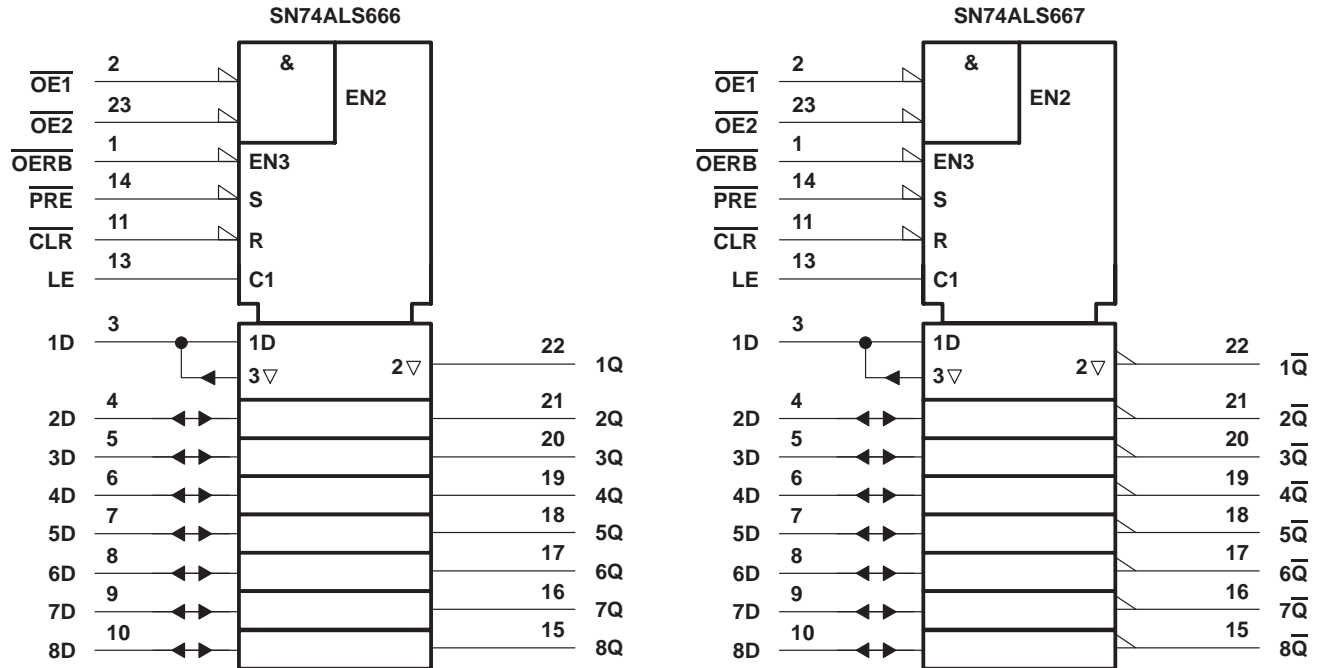

† These symbols are in accordance with ANSI/IEEE Std 91-1984 and IEC Publication 617-12.

SN74ALS666, SN74ALS667 8-BIT D-TYPE TRANSPARENT READ-BACK LATCHES WITH 3-STATE OUTPUTS

SDAS227A – JUNE 1984 – REVISED JANUARY 1995

logic diagrams (positive logic)

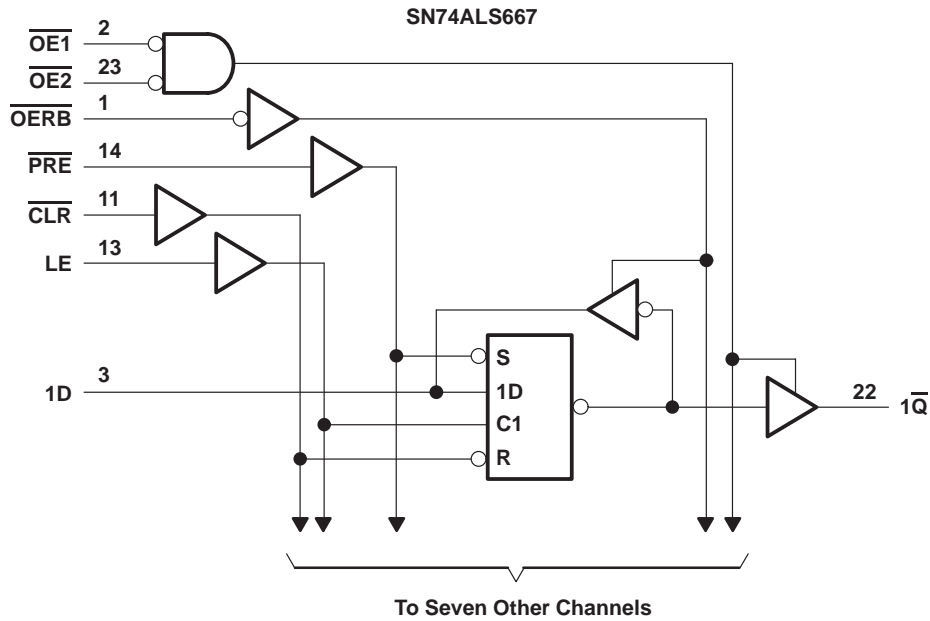
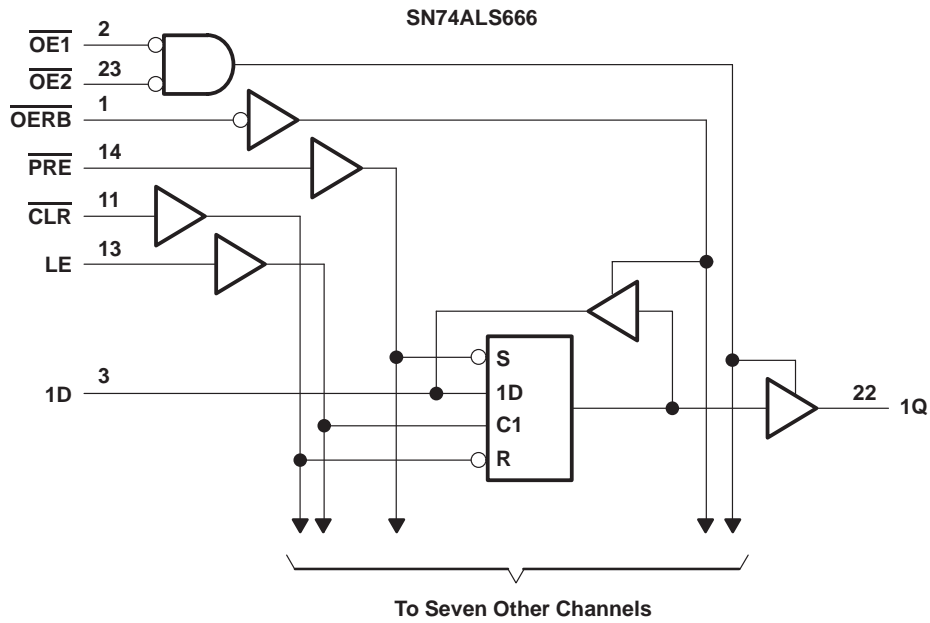

SN74ALS666, SN74ALS667

8-BIT D-TYPE TRANSPARENT READ-BACK LATCHES WITH 3-STATE OUTPUTS

SDAS227A – JUNE 1984 – REVISED JANUARY 1995

timing diagram

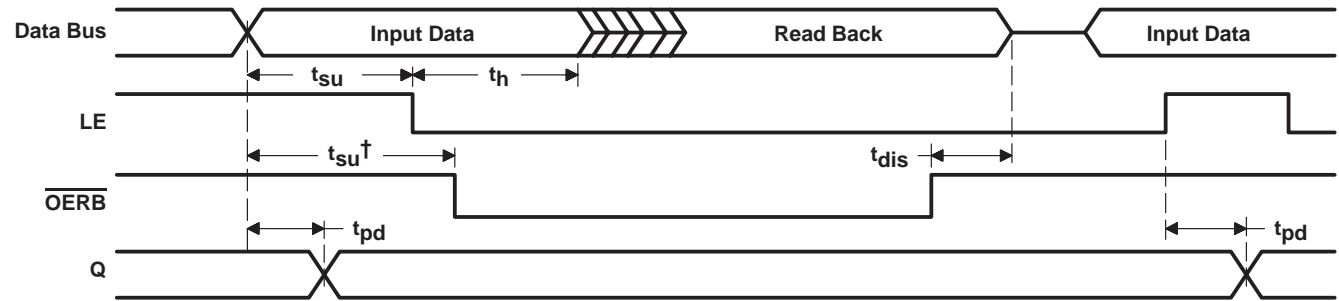

$\overline{\text{CLR}} = \text{H}$, $\overline{\text{PRE}} = \text{H}$, $\overline{\text{OE1}} = \text{L}$, $\overline{\text{OE2}} = \text{L}$.

† This setup time ensures the read-back circuit does not create a conflict on the input data bus.

absolute maximum ratings over operating free-air temperature range (unless otherwise noted)‡

Supply voltage, V_{CC}	7 V
Input voltage, V_I (all inputs except D inputs)	7 V
Voltage applied to D inputs and to disabled 3-state outputs	5.5 V
Operating free-air temperature range, T_A : SN74ALS666, SN74ALS667	0°C to 70°C
Storage temperature range	-65°C to 150°C

‡ Stresses beyond those listed under “absolute maximum ratings” may cause permanent damage to the device. These are stress ratings only, and functional operation of the device at these or any other conditions beyond those indicated under “recommended operating conditions” is not implied. Exposure to absolute-maximum-rated conditions for extended periods may affect device reliability.

recommended operating conditions

		SN74ALS666 SN74ALS667			UNIT	
		MIN	NOM	MAX		
V_{CC}	Supply voltage	4.5	5	5.5	V	
V_{IH}	High-level input voltage	2			V	
V_{IL}	Low-level input voltage			0.8	V	
I_{OH}	High-level output current			-2.6	mA	
				-0.4		
I_{OL}	Low-level output current			24	mA	
				8		
t_w	Pulse duration	LE high		10	ns	
		$\overline{\text{CLR}}$ low		10		
		$\overline{\text{PRE}}$ low		10		
t_{su}	Setup time	Data before LE↓		10	ns	
		Data before OERB↓		10		
t_h	Hold time, data after LE↓			5	ns	
T_A	Operating free-air temperature			0	70	°C



SN74ALS666, SN74ALS667 8-BIT D-TYPE TRANSPARENT READ-BACK LATCHES WITH 3-STATE OUTPUTS

SDAS227A – JUNE 1984 – REVISED JANUARY 1995

electrical characteristics over recommended operating free-air temperature range (unless otherwise noted)

PARAMETER		TEST CONDITIONS		SN74ALS666 SN74ALS667			UNIT
				MIN	TYP†	MAX	
V _{IK}		V _{CC} = 4.5 V,	I _I = -18 mA			-1.2	V
V _{OH}	All outputs	V _{CC} = 4.5 V to 5.5 V,	I _{OH} = -0.4 mA	V _{CC} - 2			V
	Q or \bar{Q}	V _{CC} = 4.5 V,	I _{OH} = -2.6 mA	2.4	3.2		
V _{OL}	D inputs	V _{CC} = 4.5 V	I _{OL} = 4 mA	0.25	0.4	V	
			I _{OL} = 8 mA	0.35	0.5		
	Q or \bar{Q}	V _{CC} = 4.5 V	I _{OL} = 12 mA	0.25	0.4		
			I _{OL} = 24 mA	0.35	0.5		
I _{OZH}	Q or \bar{Q}	V _{CC} = 5.5 V,	V _O = 2.7 V			20	μA
I _{OZL}	Q or \bar{Q}	V _{CC} = 5.5 V,	V _O = 0.4 V			-20	μA
I _I	D inputs	V _{CC} = 5.5 V	V _I = 5.5 V			0.1	mA
	All others		V _I = 7 V			0.1	
I _{IH}	D inputs‡	V _{CC} = 5.5 V,	V _I = 2.7 V			20	μA
	All others					20	
I _{IL}	D inputs‡	V _{CC} = 5.5 V,	V _I = 0.4 V			-0.1	mA
	All others					-0.1	
I _{O§}		V _{CC} = 5.5 V,	V _O = 2.25 V	-30	-112		mA
I _{CC}	SN74ALS666	V _{CC} = 5.5 V, OERB high	Q outputs high	25	50	mA	
			Q outputs low	40	73		
			Q outputs disabled	30	55		
	SN74ALS667	V _{CC} = 5.5 V, OERB high	\bar{Q} outputs high	25	50		
			\bar{Q} outputs low	45	79		
			\bar{Q} outputs disabled	30	60		

† All typical values are at V_{CC} = 5 V, T_A = 25°C.

‡ For I/O ports (Q_A through Q_H), the parameters I_{IH} and I_{IL} include the off-state output current.

§ The output conditions have been chosen to produce a current that closely approximates one half of the true short-circuit output current, I_{OS}.

SN74ALS666, SN74ALS667

8-BIT D-TYPE TRANSPARENT READ-BACK LATCHES WITH 3-STATE OUTPUTS

SDAS227A – JUNE 1984 – REVISED JANUARY 1995

switching characteristics (see Figure 1)

PARAMETER	FROM (INPUT)	TO (OUTPUT)	V _{CC} = 4.5 V to 5.5 V, C _L = 50 pF, T _A = MIN to MAX†		UNIT
			SN74ALS666		
			MIN	MAX	
t _{PLH}	D	Q	3	14	ns
t _{PHL}			4	18	
t _{PLH}	LE	Q	6	21	ns
t _{PHL}			8	27	
t _{PHL}	$\overline{\text{CLR}}$	Q	9	29	ns
		D	11	32	
t _{PLH}	$\overline{\text{PRE}}$	Q	7	22	ns
		D	9	28	
t _{en} ‡	$\overline{\text{OERB}}$	D	4	21	ns
	$\overline{\text{OE1}}, \overline{\text{OE2}}$	Q	4	21	
t _{dis} §	$\overline{\text{OERB}}$	D	1	14	ns
	$\overline{\text{OE1}}, \overline{\text{OE2}}$	Q	1	14	

† For conditions shown as MIN or MAX, use the appropriate value specified under recommended operating conditions.

‡ t_{en} = t_{PZH} or t_{PZL}

§ t_{dis} = t_{PHZ} or t_{PLZ}

switching characteristics (see Figure 1)

PARAMETER	FROM (INPUT)	TO (OUTPUT)	V _{CC} = 4.5 V to 5.5 V, C _L = 50 pF, T _A = MIN to MAX†		UNIT
			SN74ALS667		
			MIN	MAX	
t _{PLH}	D	$\overline{\text{Q}}$	6	20	ns
t _{PHL}			4	15	
t _{PLH}	LE	$\overline{\text{Q}}$	9	28	ns
t _{PHL}			7	22	
t _{PHL}	$\overline{\text{CLR}}$	$\overline{\text{Q}}$	7	24	ns
		D	8	26	
t _{PLH}	$\overline{\text{PRE}}$	$\overline{\text{Q}}$	8	25	ns
		D	9	28	
t _{en} ‡	$\overline{\text{OERB}}$	D	4	21	ns
	$\overline{\text{OE1}}, \overline{\text{OE2}}$	$\overline{\text{Q}}$	4	21	
t _{dis} §	$\overline{\text{OERB}}$	D	1	14	ns
	$\overline{\text{OE1}}, \overline{\text{OE2}}$	$\overline{\text{Q}}$	1	14	

† For conditions shown as MIN or MAX, use the appropriate value specified under recommended operating conditions.

‡ t_{en} = t_{PZH} or t_{PZL}

§ t_{dis} = t_{PHZ} or t_{PLZ}

SN74ALS666, SN74ALS667 8-BIT D-TYPE TRANSPARENT READ-BACK LATCHES WITH 3-STATE OUTPUTS

SDAS227A – JUNE 1984 – REVISED JANUARY 1995

PARAMETER MEASUREMENT INFORMATION

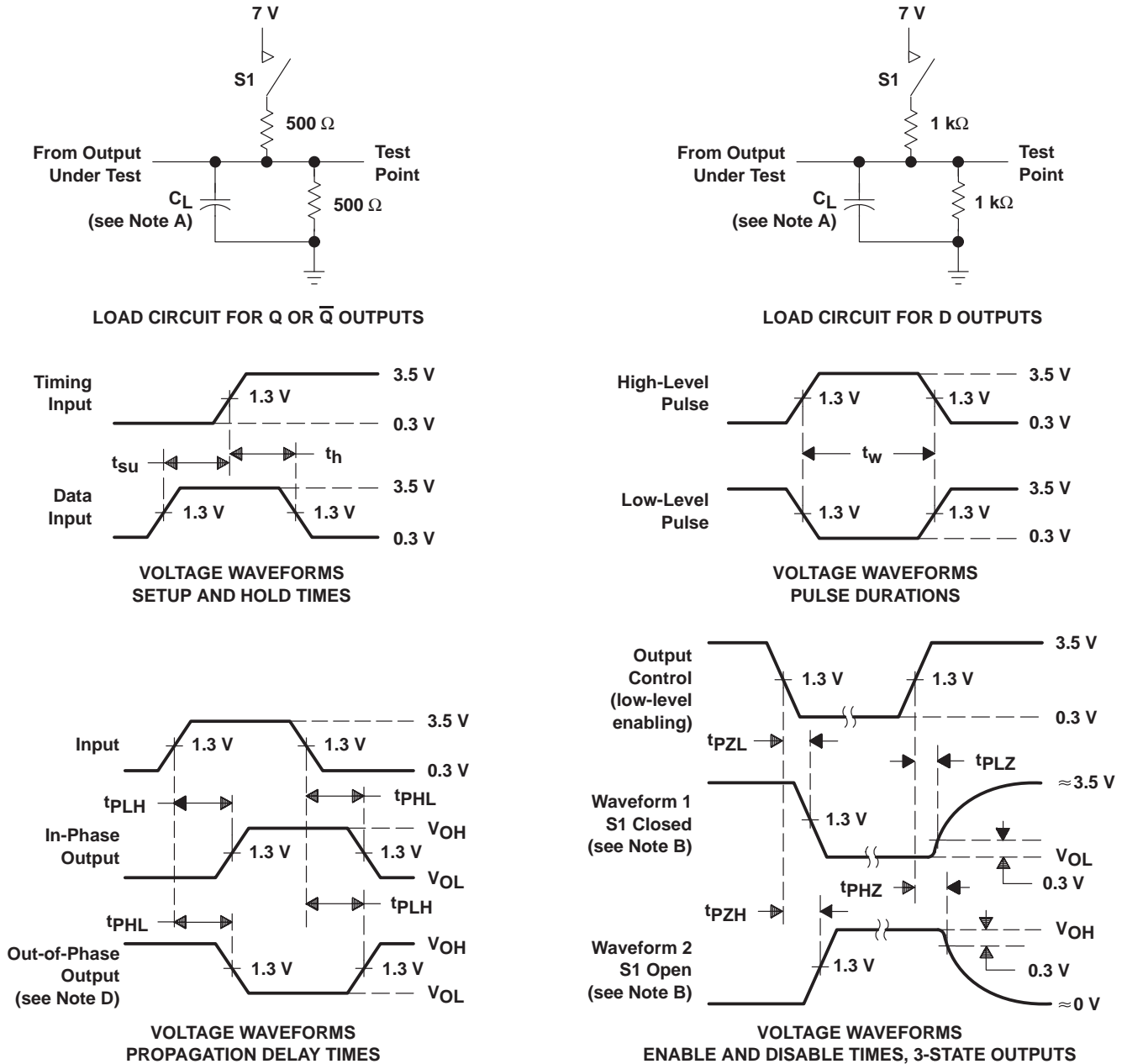

- NOTES:
- A. C_L includes probe and jig capacitance.
 - B. Waveform 1 is for an output with internal conditions such that the output is low except when disabled by the output control. Waveform 2 is for an output with internal conditions such that the output is high except when disabled by the output control.
 - C. All input pulses have the following characteristics: $PRR \leq 1$ MHz, $t_r = t_f = 2$ ns, duty cycle = 50%.
 - D. When measuring propagation delay times of 3-state outputs, switch S1 is open.

Figure 1. Load Circuits and Voltage Waveforms

PACKAGING INFORMATION

Orderable Device	Status ⁽¹⁾	Package Type	Package Drawing	Pins	Package Qty	Eco Plan ⁽²⁾	Lead/Ball Finish	MSL Peak Temp ⁽³⁾
SN74ALS666DW	ACTIVE	SOIC	DW	24	25	Green (RoHS & no Sb/Br)	CU NIPDAU	Level-1-260C-UNLIM
SN74ALS666DWE4	ACTIVE	SOIC	DW	24	25	Green (RoHS & no Sb/Br)	CU NIPDAU	Level-1-260C-UNLIM
SN74ALS666DWG4	ACTIVE	SOIC	DW	24	25	Green (RoHS & no Sb/Br)	CU NIPDAU	Level-1-260C-UNLIM
SN74ALS666DWR	ACTIVE	SOIC	DW	24	2000	Green (RoHS & no Sb/Br)	CU NIPDAU	Level-1-260C-UNLIM
SN74ALS666DWRE4	ACTIVE	SOIC	DW	24	2000	Green (RoHS & no Sb/Br)	CU NIPDAU	Level-1-260C-UNLIM
SN74ALS666DWRG4	ACTIVE	SOIC	DW	24	2000	Green (RoHS & no Sb/Br)	CU NIPDAU	Level-1-260C-UNLIM
SN74ALS666NSR	ACTIVE	SO	NS	24	2000	Green (RoHS & no Sb/Br)	CU NIPDAU	Level-1-260C-UNLIM
SN74ALS666NSRE4	ACTIVE	SO	NS	24	2000	Green (RoHS & no Sb/Br)	CU NIPDAU	Level-1-260C-UNLIM
SN74ALS666NSRG4	ACTIVE	SO	NS	24	2000	Green (RoHS & no Sb/Br)	CU NIPDAU	Level-1-260C-UNLIM
SN74ALS666NT	ACTIVE	PDIP	NT	24	15	Pb-Free (RoHS)	CU NIPDAU	N / A for Pkg Type
SN74ALS666NTE4	ACTIVE	PDIP	NT	24	15	Pb-Free (RoHS)	CU NIPDAU	N / A for Pkg Type
SN74ALS667DW	ACTIVE	SOIC	DW	24	25	Green (RoHS & no Sb/Br)	CU NIPDAU	Level-1-260C-UNLIM
SN74ALS667DWE4	ACTIVE	SOIC	DW	24	25	Green (RoHS & no Sb/Br)	CU NIPDAU	Level-1-260C-UNLIM
SN74ALS667DWG4	ACTIVE	SOIC	DW	24	25	Green (RoHS & no Sb/Br)	CU NIPDAU	Level-1-260C-UNLIM
SN74ALS667DWR	ACTIVE	SOIC	DW	24	2000	Green (RoHS & no Sb/Br)	CU NIPDAU	Level-1-260C-UNLIM
SN74ALS667DWRE4	ACTIVE	SOIC	DW	24	2000	Green (RoHS & no Sb/Br)	CU NIPDAU	Level-1-260C-UNLIM
SN74ALS667DWRG4	ACTIVE	SOIC	DW	24	2000	Green (RoHS & no Sb/Br)	CU NIPDAU	Level-1-260C-UNLIM
SN74ALS667NSR	ACTIVE	SO	NS	24	2000	Green (RoHS & no Sb/Br)	CU NIPDAU	Level-1-260C-UNLIM
SN74ALS667NSRE4	ACTIVE	SO	NS	24	2000	Green (RoHS & no Sb/Br)	CU NIPDAU	Level-1-260C-UNLIM
SN74ALS667NSRG4	ACTIVE	SO	NS	24	2000	Green (RoHS & no Sb/Br)	CU NIPDAU	Level-1-260C-UNLIM
SN74ALS667NT	ACTIVE	PDIP	NT	24	15	Pb-Free (RoHS)	CU NIPDAU	N / A for Pkg Type
SN74ALS667NT3	OBSOLETE	PDIP	NT	24		TBD	Call TI	Call TI
SN74ALS667NTE4	ACTIVE	PDIP	NT	24	15	Pb-Free (RoHS)	CU NIPDAU	N / A for Pkg Type

⁽¹⁾ The marketing status values are defined as follows:

ACTIVE: Product device recommended for new designs.

LIFEBUY: TI has announced that the device will be discontinued, and a lifetime-buy period is in effect.

NRND: Not recommended for new designs. Device is in production to support existing customers, but TI does not recommend using this part in

a new design.

PREVIEW: Device has been announced but is not in production. Samples may or may not be available.

OBSOLETE: TI has discontinued the production of the device.

⁽²⁾ Eco Plan - The planned eco-friendly classification: Pb-Free (RoHS), Pb-Free (RoHS Exempt), or Green (RoHS & no Sb/Br) - please check <http://www.ti.com/productcontent> for the latest availability information and additional product content details.

TBD: The Pb-Free/Green conversion plan has not been defined.

Pb-Free (RoHS): TI's terms "Lead-Free" or "Pb-Free" mean semiconductor products that are compatible with the current RoHS requirements for all 6 substances, including the requirement that lead not exceed 0.1% by weight in homogeneous materials. Where designed to be soldered at high temperatures, TI Pb-Free products are suitable for use in specified lead-free processes.

Pb-Free (RoHS Exempt): This component has a RoHS exemption for either 1) lead-based flip-chip solder bumps used between the die and package, or 2) lead-based die adhesive used between the die and leadframe. The component is otherwise considered Pb-Free (RoHS compatible) as defined above.

Green (RoHS & no Sb/Br): TI defines "Green" to mean Pb-Free (RoHS compatible), and free of Bromine (Br) and Antimony (Sb) based flame retardants (Br or Sb do not exceed 0.1% by weight in homogeneous material)

⁽³⁾ MSL, Peak Temp. -- The Moisture Sensitivity Level rating according to the JEDEC industry standard classifications, and peak solder temperature.

Important Information and Disclaimer:The information provided on this page represents TI's knowledge and belief as of the date that it is provided. TI bases its knowledge and belief on information provided by third parties, and makes no representation or warranty as to the accuracy of such information. Efforts are underway to better integrate information from third parties. TI has taken and continues to take reasonable steps to provide representative and accurate information but may not have conducted destructive testing or chemical analysis on incoming materials and chemicals. TI and TI suppliers consider certain information to be proprietary, and thus CAS numbers and other limited information may not be available for release.

In no event shall TI's liability arising out of such information exceed the total purchase price of the TI part(s) at issue in this document sold by TI to Customer on an annual basis.

TAPE AND REEL INFORMATION



QUADRANT ASSIGNMENTS FOR PIN 1 ORIENTATION IN TAPE



*All dimensions are nominal

Device	Package Type	Package Drawing	Pins	SPQ	Reel Diameter (mm)	Reel Width W1 (mm)	A0 (mm)	B0 (mm)	K0 (mm)	P1 (mm)	W (mm)	Pin1 Quadrant
SN74ALS666DWR	SOIC	DW	24	2000	330.0	24.4	10.75	15.7	2.7	12.0	24.0	Q1
SN74ALS666NSR	SO	NS	24	2000	330.0	24.4	8.2	15.4	2.5	12.0	24.0	Q1
SN74ALS667DWR	SOIC	DW	24	2000	330.0	24.4	10.75	15.7	2.7	12.0	24.0	Q1
SN74ALS667NSR	SO	NS	24	2000	330.0	24.4	8.2	15.4	2.5	12.0	24.0	Q1

TAPE AND REEL BOX DIMENSIONS



*All dimensions are nominal

Device	Package Type	Package Drawing	Pins	SPQ	Length (mm)	Width (mm)	Height (mm)
SN74ALS666DWR	SOIC	DW	24	2000	346.0	346.0	41.0
SN74ALS666NSR	SO	NS	24	2000	346.0	346.0	41.0
SN74ALS667DWR	SOIC	DW	24	2000	346.0	346.0	41.0
SN74ALS667NSR	SO	NS	24	2000	346.0	346.0	41.0

MECHANICAL DATA

NS (R-PDSO-G**)

PLASTIC SMALL-OUTLINE PACKAGE

14-PINS SHOWN



- NOTES:
- A. All linear dimensions are in millimeters.
 - B. This drawing is subject to change without notice.
 - C. Body dimensions do not include mold flash or protrusion, not to exceed 0,15.

NT (R-PDIP-T**)

PLASTIC DUAL-IN-LINE PACKAGE

24 PINS SHOWN

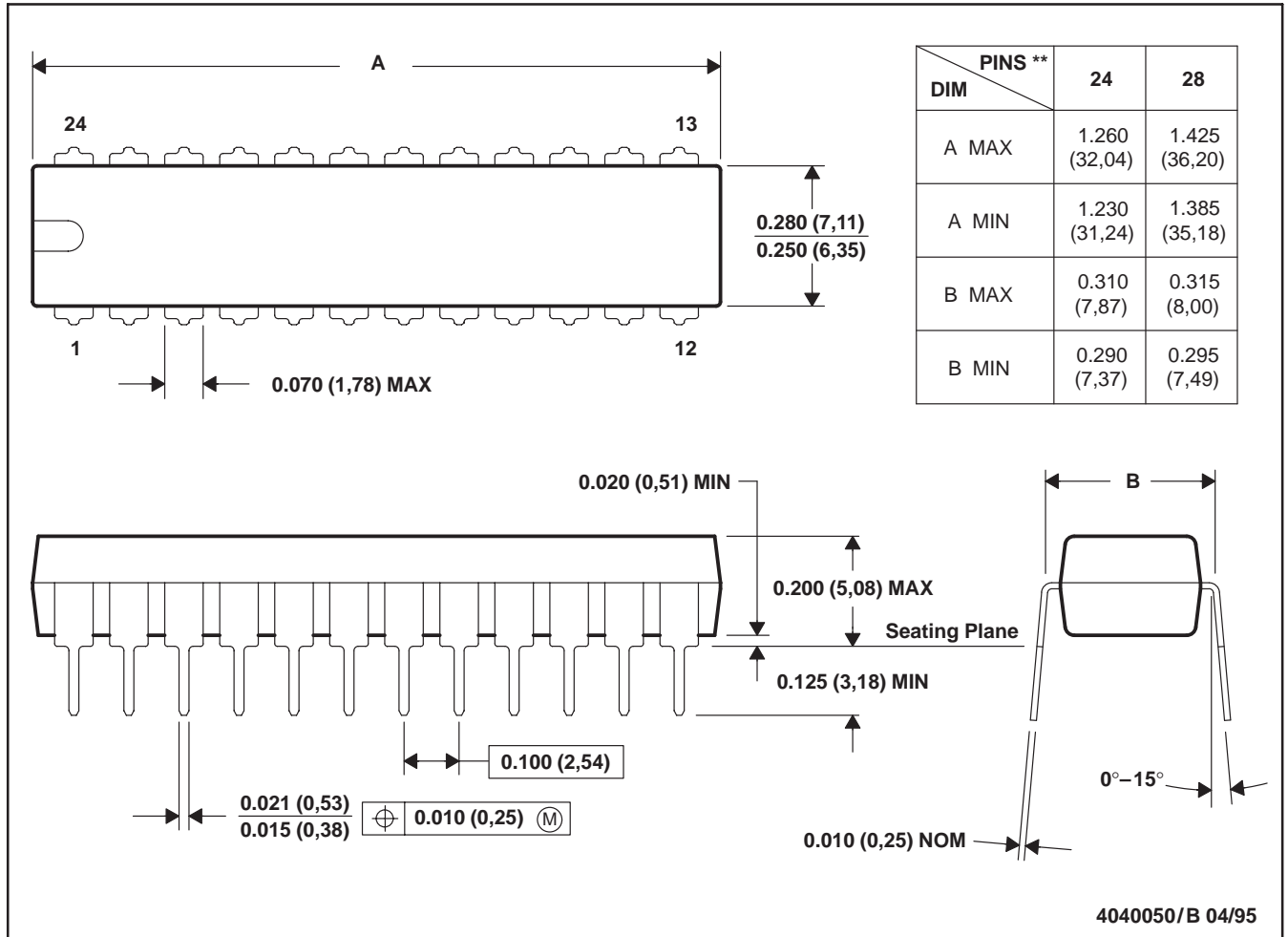

- NOTES: A. All linear dimensions are in inches (millimeters).
 B. This drawing is subject to change without notice.

IMPORTANT NOTICE

Texas Instruments Incorporated and its subsidiaries (TI) reserve the right to make corrections, modifications, enhancements, improvements, and other changes to its products and services at any time and to discontinue any product or service without notice. Customers should obtain the latest relevant information before placing orders and should verify that such information is current and complete. All products are sold subject to TI's terms and conditions of sale supplied at the time of order acknowledgment.

TI warrants performance of its hardware products to the specifications applicable at the time of sale in accordance with TI's standard warranty. Testing and other quality control techniques are used to the extent TI deems necessary to support this warranty. Except where mandated by government requirements, testing of all parameters of each product is not necessarily performed.

TI assumes no liability for applications assistance or customer product design. Customers are responsible for their products and applications using TI components. To minimize the risks associated with customer products and applications, customers should provide adequate design and operating safeguards.

TI does not warrant or represent that any license, either express or implied, is granted under any TI patent right, copyright, mask work right, or other TI intellectual property right relating to any combination, machine, or process in which TI products or services are used. Information published by TI regarding third-party products or services does not constitute a license from TI to use such products or services or a warranty or endorsement thereof. Use of such information may require a license from a third party under the patents or other intellectual property of the third party, or a license from TI under the patents or other intellectual property of TI.

Reproduction of TI information in TI data books or data sheets is permissible only if reproduction is without alteration and is accompanied by all associated warranties, conditions, limitations, and notices. Reproduction of this information with alteration is an unfair and deceptive business practice. TI is not responsible or liable for such altered documentation. Information of third parties may be subject to additional restrictions.

Resale of TI products or services with statements different from or beyond the parameters stated by TI for that product or service voids all express and any implied warranties for the associated TI product or service and is an unfair and deceptive business practice. TI is not responsible or liable for any such statements.

TI products are not authorized for use in safety-critical applications (such as life support) where a failure of the TI product would reasonably be expected to cause severe personal injury or death, unless officers of the parties have executed an agreement specifically governing such use. Buyers represent that they have all necessary expertise in the safety and regulatory ramifications of their applications, and acknowledge and agree that they are solely responsible for all legal, regulatory and safety-related requirements concerning their products and any use of TI products in such safety-critical applications, notwithstanding any applications-related information or support that may be provided by TI. Further, Buyers must fully indemnify TI and its representatives against any damages arising out of the use of TI products in such safety-critical applications.

TI products are neither designed nor intended for use in military/aerospace applications or environments unless the TI products are specifically designated by TI as military-grade or "enhanced plastic." Only products designated by TI as military-grade meet military specifications. Buyers acknowledge and agree that any such use of TI products which TI has not designated as military-grade is solely at the Buyer's risk, and that they are solely responsible for compliance with all legal and regulatory requirements in connection with such use.

TI products are neither designed nor intended for use in automotive applications or environments unless the specific TI products are designated by TI as compliant with ISO/TS 16949 requirements. Buyers acknowledge and agree that, if they use any non-designated products in automotive applications, TI will not be responsible for any failure to meet such requirements.

Following are URLs where you can obtain information on other Texas Instruments products and application solutions:

Products

Amplifiers	amplifier.ti.com
Data Converters	dataconverter.ti.com
DSP	dsp.ti.com
Clocks and Timers	www.ti.com/clocks
Interface	interface.ti.com
Logic	logic.ti.com
Power Mgmt	power.ti.com
Microcontrollers	microcontroller.ti.com
RFID	www.ti-rfid.com
RF/IF and ZigBee® Solutions	www.ti.com/lprf

Applications

Audio	www.ti.com/audio
Automotive	www.ti.com/automotive
Broadband	www.ti.com/broadband
Digital Control	www.ti.com/digitalcontrol
Medical	www.ti.com/medical
Military	www.ti.com/military
Optical Networking	www.ti.com/opticalnetwork
Security	www.ti.com/security
Telephony	www.ti.com/telephony
Video & Imaging	www.ti.com/video
Wireless	www.ti.com/wireless

Mailing Address: Texas Instruments, Post Office Box 655303, Dallas, Texas 75265
Copyright © 2008, Texas Instruments Incorporated