

# SN54ALS645A, SN54AS645, SN74ALS645A, SN74AS645 OCTAL BUS TRANSCEIVERS WITH 3-STATE OUTPUTS

SDAS278 – JANUARY 1995

- Bidirectional Bus Transceivers in High-Density 20-Pin Packages
- True Logic
- 3-State Outputs
- Package Options Include Plastic Small-Outline (DW) Packages, Ceramic Chip Carriers (FK), and Standard Plastic (N) and Ceramic (J) 300-mil DIPs

## description

These octal bus transceivers are designed for asynchronous two-way communication between data buses. These devices transmit data from the A bus to the B bus or from the B bus to the A bus, depending on the level at the direction-control (DIR) input. The output-enable ( $\overline{OE}$ ) input can be used to disable the device so that the buses are effectively isolated.

The -1 version of the SN74ALS645A is identical to the standard version, except that the recommended maximum  $I_{OL}$  is increased to 48 mA. There is no -1 version of the SN54ALS645A.

The SN54ALS645A and SN54AS645 are characterized for operation over the full military temperature range of  $-55^{\circ}\text{C}$  to  $125^{\circ}\text{C}$ . The SN74ALS645A and SN74AS645 are characterized for operation from  $0^{\circ}\text{C}$  to  $70^{\circ}\text{C}$ .

SN54ALS645A, SN54AS645 . . . J PACKAGE  
SN74ALS645A, SN74AS645 . . . DW OR N PACKAGE  
(TOP VIEW)

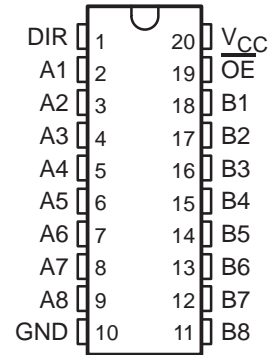

SN54ALS645A, SN54AS645 . . . FK PACKAGE  
(TOP VIEW)

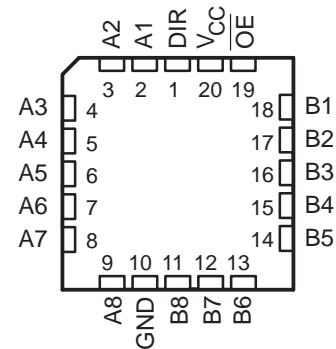

FUNCTION TABLE

INPUTS		OPERATION
$\overline{OE}$	DIR	
L	L	B data to A bus
L	H	A data to B bus
H	X	Isolation

# SN54ALS645A, SN54AS645, SN74ALS645A, SN74AS645 OCTAL BUS TRANSCEIVERS WITH 3-STATE OUTPUTS

SDAS278 – JANUARY 1995

## logic symbol†

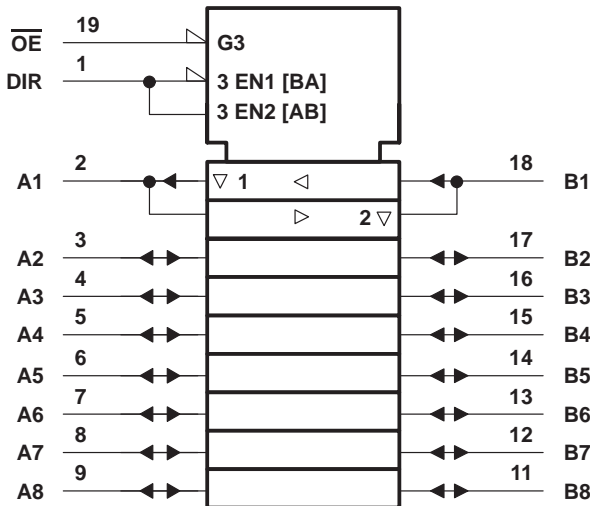

## logic diagram (positive logic)

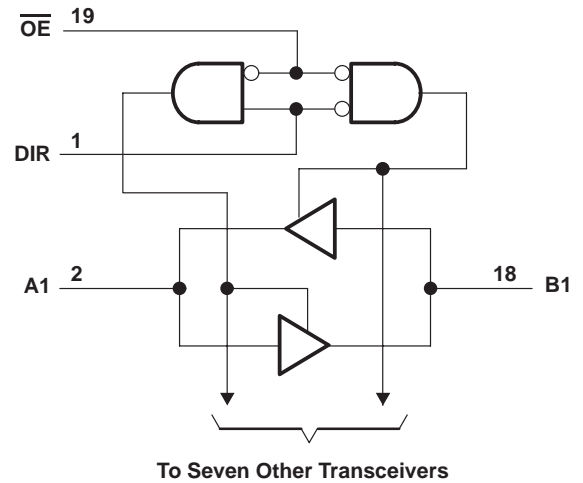

† This symbol is in accordance with ANSI/IEEE Std 91-1984 and IEC Publication 617-12.

## absolute maximum ratings over operating free-air temperature range (unless otherwise noted)‡

Supply voltage, $V_{CC}$	7 V
Input voltage, $V_I$ : All inputs	7 V
I/O ports	5.5 V
Operating free-air temperature range, $T_A$ : SN54ALS645A	-55°C to 125°C
SN74ALS645A	0°C to 70°C
Storage temperature range	-65°C to 150°C

‡ Stresses beyond those listed under "absolute maximum ratings" may cause permanent damage to the device. These are stress ratings only, and functional operation of the device at these or any other conditions beyond those indicated under "recommended operating conditions" is not implied. Exposure to absolute-maximum-rated conditions for extended periods may affect device reliability.

## recommended operating conditions

	SN54ALS645A			SN74ALS645A			UNIT
	MIN	NOM	MAX	MIN	NOM	MAX	
$V_{CC}$ Supply voltage	4.5	5	5.5	4.5	5	5.5	V
$V_{IH}$ High-level input voltage	2			2			V
$V_{IL}$ Low-level input voltage			0.7			0.8	V
$I_{OH}$ High-level output current			-12			-15	mA
$I_{OL}$ Low-level output current			12			24	mA
						48§	
$T_A$ Operating free-air temperature	-55		125	0		70	°C

§ Applies only to the -1 version and only if  $V_{CC}$  is between 4.75 V and 5.25 V

**SN54ALS645A, SN54AS645, SN74ALS645A, SN74AS645**  
**OCTAL BUS TRANSCEIVERS**  
**WITH 3-STATE OUTPUTS**

SDAS278 – JANUARY 1995

**electrical characteristics over recommended operating free-air temperature range (unless otherwise noted)**

PARAMETER	TEST CONDITIONS	SN54ALS645A		SN74ALS645A		UNIT	
		MIN	TYP†	MAX	MIN		TYP†
$V_{IK}$	$V_{CC} = 4.5\text{ V}$ , $I_I = -18\text{ mA}$			-1.5		-1.5	V
$V_{OH}$	$V_{CC} = 4.5\text{ V to }5.5\text{ V}$ , $I_{OH} = -0.4\text{ mA}$	$V_{CC} - 2$		$V_{CC} - 2$		V	
	$V_{CC} = 4.5\text{ V}$	$I_{OH} = -3\text{ mA}$	2.4	3.2	2.4		3.2
		$I_{OH} = -12\text{ mA}$	2				
$V_{OL}$	$V_{CC} = 4.5\text{ V}$	$I_{OL} = 12\text{ mA}$	0.25	0.4	0.25	0.4	V
		$I_{OL} = 24\text{ mA}$			0.35	0.5	
		$I_{OL} = 48\text{ mA}^\ddagger$			0.35	0.5	
$I_I$	Control inputs	$V_{CC} = 5.5\text{ V}$	$V_I = 7\text{ V}$	0.1		0.1	mA
	A or B ports		$V_I = 5.5\text{ V}$	0.1		0.1	
$I_{IH}$	Control inputs	$V_{CC} = 5.5\text{ V}$ , $V_I = 2.7\text{ V}$	20		20		$\mu\text{A}$
	A or B ports§		20		20		
$I_{IL}$	Control inputs	$V_{CC} = 5.5\text{ V}$ , $V_I = 0.4\text{ V}$	-0.1		-0.1		mA
	A or B ports§		-0.1		-0.1		
$I_{O}^\parallel$	$V_{CC} = 5.5\text{ V}$ , $V_O = 2.25\text{ V}$	-20	-112	-30	-112	mA	
$I_{CC}$	$V_{CC} = 5.5\text{ V}$	Outputs high	30	48	30	45	mA
		Outputs low	36	60	36	55	
		Outputs disabled	38	63	38	58	

† All typical values are at  $V_{CC} = 5\text{ V}$ ,  $T_A = 25^\circ\text{C}$ .

‡ Applies only to the -1 version and only if  $V_{CC}$  is between 4.75 V and 5.25 V

§ For I/O ports, the parameters  $I_{IH}$  and  $I_{IL}$  include the off-state output current.

¶ The output conditions have been chosen to produce a current that closely approximates one half of the true short-circuit output current,  $I_{OS}$ .

**switching characteristics (see Figure 1)**

PARAMETER	FROM (INPUT)	TO (OUTPUT)	$V_{CC} = 4.5\text{ V to }5.5\text{ V}$ , $C_L = 50\text{ pF}$ , $R_1 = 500\ \Omega$ , $R_2 = 500\ \Omega$ , $T_A = \text{MIN to MAX}^\#$				UNIT
			SN54ALS645A		SN74ALS645A		
			MIN	MAX	MIN	MAX	
$t_{PLH}$	A or B	B or A	1	19	3	10	ns
$t_{PHL}$			1	14	3	10	
$t_{PZH}$	$\overline{OE}$	A or B	2	30	5	20	ns
$t_{PZL}$			2	29	5	20	
$t_{PHZ}$	$\overline{OE}$	A or B	2	14	2	10	ns
$t_{PLZ}$			2	30	4	15	

# For conditions shown as MIN or MAX, use the appropriate value specified under recommended operating conditions.

# SN54ALS645A, SN54AS645, SN74ALS645A, SN74AS645

## OCTAL BUS TRANSCEIVERS

### WITH 3-STATE OUTPUTS

SDAS278 – JANUARY 1995

#### absolute maximum ratings over operating free-air temperature range (unless otherwise noted)†

Supply voltage, $V_{CC}$	7 V
Input voltage, $V_I$ : All inputs	7 V
I/O ports	5.5 V
Operating free-air temperature range, $T_A$ : SN54AS645	-55°C to 125°C
SN74AS645	0°C to 70°C
Storage temperature range	-65°C to 150°C

† Stresses beyond those listed under “absolute maximum ratings” may cause permanent damage to the device. These are stress ratings only, and functional operation of the device at these or any other conditions beyond those indicated under “recommended operating conditions” is not implied. Exposure to absolute-maximum-rated conditions for extended periods may affect device reliability.

#### recommended operating conditions

		SN54AS645			SN74AS645			UNIT
		MIN	NOM	MAX	MIN	NOM	MAX	
$V_{CC}$	Supply voltage	4.5	5	5.5	4.5	5	5.5	V
$V_{IH}$	High-level input voltage	2			2			V
$V_{IL}$	Low-level input voltage			0.8			0.8	V
$I_{OH}$	High-level output current			-12			-15	mA
$I_{OL}$	Low-level output current			48			64	mA
$T_A$	Operating free-air temperature	-55		125	0		70	°C

#### electrical characteristics over recommended operating free-air temperature range (unless otherwise noted)

PARAMETER	TEST CONDITIONS	SN54AS645			SN74AS645			UNIT
		MIN	TYP‡	MAX	MIN	TYP‡	MAX	
$V_{IK}$	$V_{CC} = 4.5\text{ V}$ , $I_I = -18\text{ mA}$			-1.2			-1.2	V
$V_{OH}$	$V_{CC} = 4.5\text{ V to }5.5\text{ V}$ , $I_{OH} = -2\text{ mA}$	$V_{CC} - 2$		$V_{CC} - 2$				V
	$V_{CC} = 4.5\text{ V}$ , $I_{OH} = -3\text{ mA}$	2.4	3.2	2.4	3.2			
	$V_{CC} = 4.5\text{ V}$ , $I_{OH} = -12\text{ mA}$	2.4						
	$V_{CC} = 4.5\text{ V}$ , $I_{OH} = -15\text{ mA}$				2.4			
$V_{OL}$	$V_{CC} = 4.5\text{ V}$ , $I_{OL} = 48\text{ mA}$		0.3	0.55				V
	$V_{CC} = 4.5\text{ V}$ , $I_{OL} = 64\text{ mA}$				0.35	0.55		
$I_I$	Control inputs A or B ports	$V_{CC} = 5.5\text{ V}$		$V_I = 7\text{ V}$		$V_I = 5.5\text{ V}$		mA
				0.1		0.1		
$I_{IH}$	Control inputs A or B ports§	$V_{CC} = 5.5\text{ V}$ , $V_I = 2.7\text{ V}$		20		20		$\mu\text{A}$
				70		70		
$I_{IL}$	Control inputs A or B ports§	$V_{CC} = 5.5\text{ V}$ , $V_I = 0.4\text{ V}$		-0.5		-0.5		mA
				-0.75		-0.75		
$I_{O}^{\parallel}$	$V_{CC} = 5.5\text{ V}$ , $V_O = 2.25\text{ V}$	-50		-150	-50		-150	mA
$I_{CC}$	$V_{CC} = 5.5\text{ V}$ , Outputs high		62	97		62	97	mA
	$V_{CC} = 5.5\text{ V}$ , Outputs low		95	149		95	149	
	$V_{CC} = 5.5\text{ V}$ , Outputs disabled		79	123		79	123	

‡ All typical values are at  $V_{CC} = 5\text{ V}$ ,  $T_A = 25^\circ\text{C}$ .

§ For I/O ports, the parameters  $I_{IH}$  and  $I_{IL}$  include the off-state output current.

¶ The output conditions have been chosen to produce a current that closely approximates one half of the true short-circuit output current,  $I_{OS}$ .



SN54ALS645A, SN54AS645, SN74ALS645A, SN74AS645  
**OCTAL BUS TRANSCEIVERS  
 WITH 3-STATE OUTPUTS**

SDAS278 – JANUARY 1995

**switching characteristics (see Figure 1)**

PARAMETER	FROM (INPUT)	TO (OUTPUT)	V <sub>CC</sub> = 4.5 V to 5.5 V, C <sub>L</sub> = 50 pF, R <sub>1</sub> = 500 Ω, R <sub>2</sub> = 500 Ω, T <sub>A</sub> = MIN to MAX†				UNIT
			SN54AS645		SN74AS645		
			MIN	MAX	MIN	MAX	
t <sub>PLH</sub>	A or B	B or A	2	11	2	9.5	ns
t <sub>PHL</sub>			2	10.5	2	9	
t <sub>PZH</sub>	$\overline{\text{OE}}$	A or B	2	12	2	11	ns
t <sub>PZL</sub>			2	12	2	10	
t <sub>PHZ</sub>	$\overline{\text{OE}}$	A or B	2	8	2	7	ns
t <sub>PLZ</sub>			2	13	2	12	

† For conditions shown as MIN or MAX, use the appropriate value specified under recommended operating conditions.

# SN54ALS645A, SN54AS645, SN74ALS645A, SN74AS645 OCTAL BUS TRANSCEIVERS WITH 3-STATE OUTPUTS

SDAS278 – JANUARY 1995

## PARAMETER MEASUREMENT INFORMATION SERIES 54ALS/74ALS AND 54AS/74AS DEVICES



- NOTES: A.  $C_L$  includes probe and jig capacitance.  
 B. Waveform 1 is for an output with internal conditions such that the output is low except when disabled by the output control. Waveform 2 is for an output with internal conditions such that the output is high except when disabled by the output control.  
 C. When measuring propagation delay items of 3-state outputs, switch S1 is open.  
 D. All input pulses have the following characteristics:  $PRR \leq 1$  MHz,  $t_r = t_f = 2$  ns, duty cycle = 50%.  
 E. The outputs are measured one at a time with one transition per measurement.

Figure 1. Load Circuits and Voltage Waveforms

**PACKAGING INFORMATION**

Orderable Device	Status <sup>(1)</sup>	Package Type	Package Drawing	Pins	Package Qty	Eco Plan <sup>(2)</sup>	Lead/Ball Finish	MSL Peak Temp <sup>(3)</sup>
84033012A	ACTIVE	LCCC	FK	20	1	TBD	Call TI	Level-NC-NC-NC
8403301RA	ACTIVE	CDIP	J	20	1	TBD	Call TI	Level-NC-NC-NC
8403301SA	ACTIVE	CFP	W	20	1	TBD	Call TI	Level-NC-NC-NC
SN54ALS645AJ	ACTIVE	CDIP	J	20	1	TBD	Call TI	Level-NC-NC-NC
SN54AS645J	ACTIVE	CDIP	J	20	1	TBD	Call TI	Level-NC-NC-NC
SN74ALS645A-1DW	ACTIVE	SOIC	DW	20	25	Pb-Free (RoHS)	CU NIPDAU	Level-2-250C-1 YEAR/ Level-1-235C-UNLIM
SN74ALS645A-1DWR	ACTIVE	SOIC	DW	20	2000	Pb-Free (RoHS)	CU NIPDAU	Level-2-250C-1 YEAR/ Level-1-235C-UNLIM
SN74ALS645A-1N	ACTIVE	PDIP	N	20	20	Pb-Free (RoHS)	CU NIPDAU	Level-NC-NC-NC
SN74ALS645A-1N3	OBSOLETE	PDIP	N	20		TBD	Call TI	Call TI
SN74ALS645A-1NSR	ACTIVE	SO	NS	20	2000	Pb-Free (RoHS)	CU NIPDAU	Level-2-260C-1 YEAR/ Level-1-235C-UNLIM
SN74ALS645ADW	ACTIVE	SOIC	DW	20	25	Pb-Free (RoHS)	CU NIPDAU	Level-2-250C-1 YEAR/ Level-1-235C-UNLIM
SN74ALS645ADWR	ACTIVE	SOIC	DW	20	2000	Pb-Free (RoHS)	CU NIPDAU	Level-2-250C-1 YEAR/ Level-1-235C-UNLIM
SN74ALS645AN	ACTIVE	PDIP	N	20	20	Pb-Free (RoHS)	CU NIPDAU	Level-NC-NC-NC
SN74ALS645AN3	OBSOLETE	PDIP	N	20		TBD	Call TI	Call TI
SN74ALS645ANSR	ACTIVE	SO	NS	20	2000	Pb-Free (RoHS)	CU NIPDAU	Level-2-260C-1 YEAR/ Level-1-235C-UNLIM
SN74AS645DW	ACTIVE	SOIC	DW	20	25	Pb-Free (RoHS)	CU NIPDAU	Level-2-250C-1 YEAR/ Level-1-235C-UNLIM
SN74AS645DWR	ACTIVE	SOIC	DW	20	2000	Pb-Free (RoHS)	CU NIPDAU	Level-2-250C-1 YEAR/ Level-1-235C-UNLIM
SN74AS645N	ACTIVE	PDIP	N	20	20	Pb-Free (RoHS)	CU NIPDAU	Level-NC-NC-NC
SNJ54ALS645AFK	ACTIVE	LCCC	FK	20	1	TBD	Call TI	Level-NC-NC-NC
SNJ54ALS645AJ	ACTIVE	CDIP	J	20	1	TBD	Call TI	Level-NC-NC-NC
SNJ54ALS645AW	ACTIVE	CFP	W	20	1	TBD	Call TI	Level-NC-NC-NC
SNJ54AS645FK	OBSOLETE	LCCC	FK	20		TBD	Call TI	Call TI
SNJ54AS645J	ACTIVE	CDIP	J	20	1	TBD	Call TI	Level-NC-NC-NC
SNJ54AS645W	ACTIVE	CFP	W	20	1	TBD	Call TI	Level-NC-NC-NC

<sup>(1)</sup> The marketing status values are defined as follows:

**ACTIVE:** Product device recommended for new designs.

**LIFEBUY:** TI has announced that the device will be discontinued, and a lifetime-buy period is in effect.

**NRND:** Not recommended for new designs. Device is in production to support existing customers, but TI does not recommend using this part in a new design.

**PREVIEW:** Device has been announced but is not in production. Samples may or may not be available.

**OBSOLETE:** TI has discontinued the production of the device.

<sup>(2)</sup> Eco Plan - The planned eco-friendly classification: Pb-Free (RoHS) or Green (RoHS & no Sb/Br) - please check <http://www.ti.com/productcontent> for the latest availability information and additional product content details.

**TBD:** The Pb-Free/Green conversion plan has not been defined.

**Pb-Free (RoHS):** TI's terms "Lead-Free" or "Pb-Free" mean semiconductor products that are compatible with the current RoHS requirements for all 6 substances, including the requirement that lead not exceed 0.1% by weight in homogeneous materials. Where designed to be soldered