

SN54ALS561A, SN74ALS561A SYNCHRONOUS 4-BIT COUNTERS WITH 3-STATE OUTPUTS

SDAS225A – DECEMBER 1982 – REVISED JANUARY 1995

- Carry Output for n-Bit Cascading
- Buffer-Type Outputs Drive Bus Lines Directly
- Choice of Asynchronous or Synchronous Clearing and Loading
- Internal Look-Ahead Circuitry for Fast Cascading
- Package Options Include Plastic Small-Outline (DW) Packages, Ceramic Chip Carriers (FK), and Standard Plastic (N) and Ceramic (J) 300-mil DIPs

description

These binary counters are programmable and offer synchronous and asynchronous clearing as well as synchronous and asynchronous loading. All synchronous functions are executed on the positive-going edge of the clock.

The clear function is initiated by applying a low level to either asynchronous clear ($\overline{\text{ACLR}}$) or synchronous clear (SCLR). $\overline{\text{ACLR}}$ (direct clear) overrides all other functions of the device, while SCLR overrides only the other synchronous functions. Data is loaded from the A, B, C, and D inputs by applying a low level to asynchronous load ($\overline{\text{ALOAD}}$) or by the combination of a low level at synchronous load ($\overline{\text{SLOAD}}$) and a positive-going clock transition. The counting function is enabled only when enable P (ENP), enable T (ENT), $\overline{\text{ACLR}}$, $\overline{\text{ALOAD}}$, SCLR , and $\overline{\text{SLOAD}}$ are all high.

A high level at the output-enable ($\overline{\text{OE}}$) input forces the Q outputs into the high-impedance state, and a low level enables those outputs. Counting is independent of $\overline{\text{OE}}$. ENT is fed forward to enable the ripple-carry output (RCO) to produce a high-level pulse while the count is maximum (15). The clocked carry output (CCO) produces a high-level pulse for a duration equal to that of the low level of the clock when RCO is high and the counter is enabled (ENP and ENT are high); otherwise, CCO is low. CCO does not have the glitches commonly associated with a ripple-carry output. Cascading is normally accomplished by connecting RCO or CCO of the first counter to ENT of the next counter. However, for very high-speed counting, RCO should be used for cascading because CCO does not become active until the clock returns to the low level.

The SN54ALS561A is characterized for operation over the full military temperature range of -55°C to 125°C . The SN74ALS561A is characterized for operation from 0°C to 70°C .

SN54ALS561A . . . J PACKAGE
SN74ALS561A . . . DW OR N PACKAGE
(TOP VIEW)

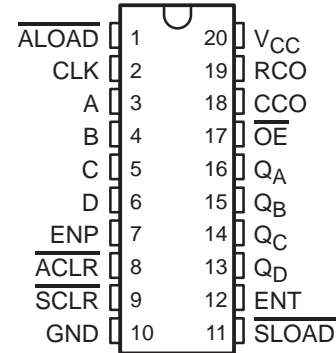

SN54ALS561A . . . FK PACKAGE
(TOP VIEW)

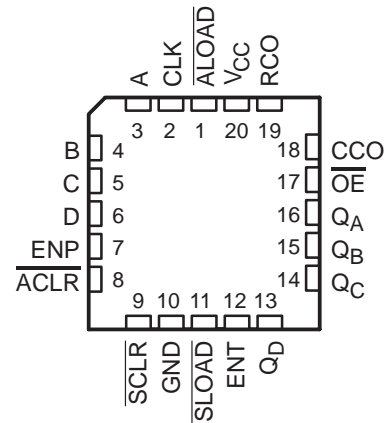

SN54ALS561A, SN74ALS561A SYNCHRONOUS 4-BIT COUNTERS WITH 3-STATE OUTPUTS

SDAS225A – DECEMBER 1982 – REVISED JANUARY 1995

FUNCTION TABLE

INPUTS								OPERATION
\overline{OE}	\overline{ACLR}	\overline{ALOAD}	\overline{SCLR}	\overline{SLOAD}	ENT	ENP	CLK	
H	X	X	X	X	X	X	X	Q outputs disabled
L	L	X	X	X	X	X	X	Asynchronous clear
L	H	L	X	X	X	X	X	Asynchronous load
L	H	H	L	X	X	X	↑	Synchronous clear
L	H	H	H	L	X	X	↑	Synchronous load
L	H	H	H	H	H	H	↑	Count
L	H	H	H	H	L	X	X	Inhibit counting
L	H	H	H	H	X	L	X	Inhibit counting

logic symbol†

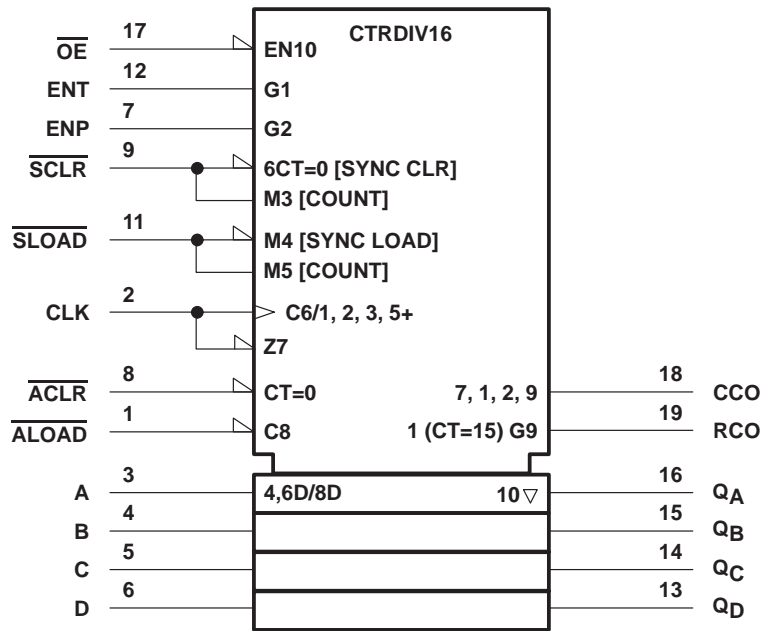

† This symbol is in accordance with ANSI/IEEE Std 91-1984 and IEC Publication 617-12.

SN54ALS561A, SN74ALS561A
 SYNCHRONOUS 4-BIT COUNTERS
 WITH 3-STATE OUTPUTS

SDAS225A – DECEMBER 1982 – REVISED JANUARY 1995

logic diagram (positive logic)

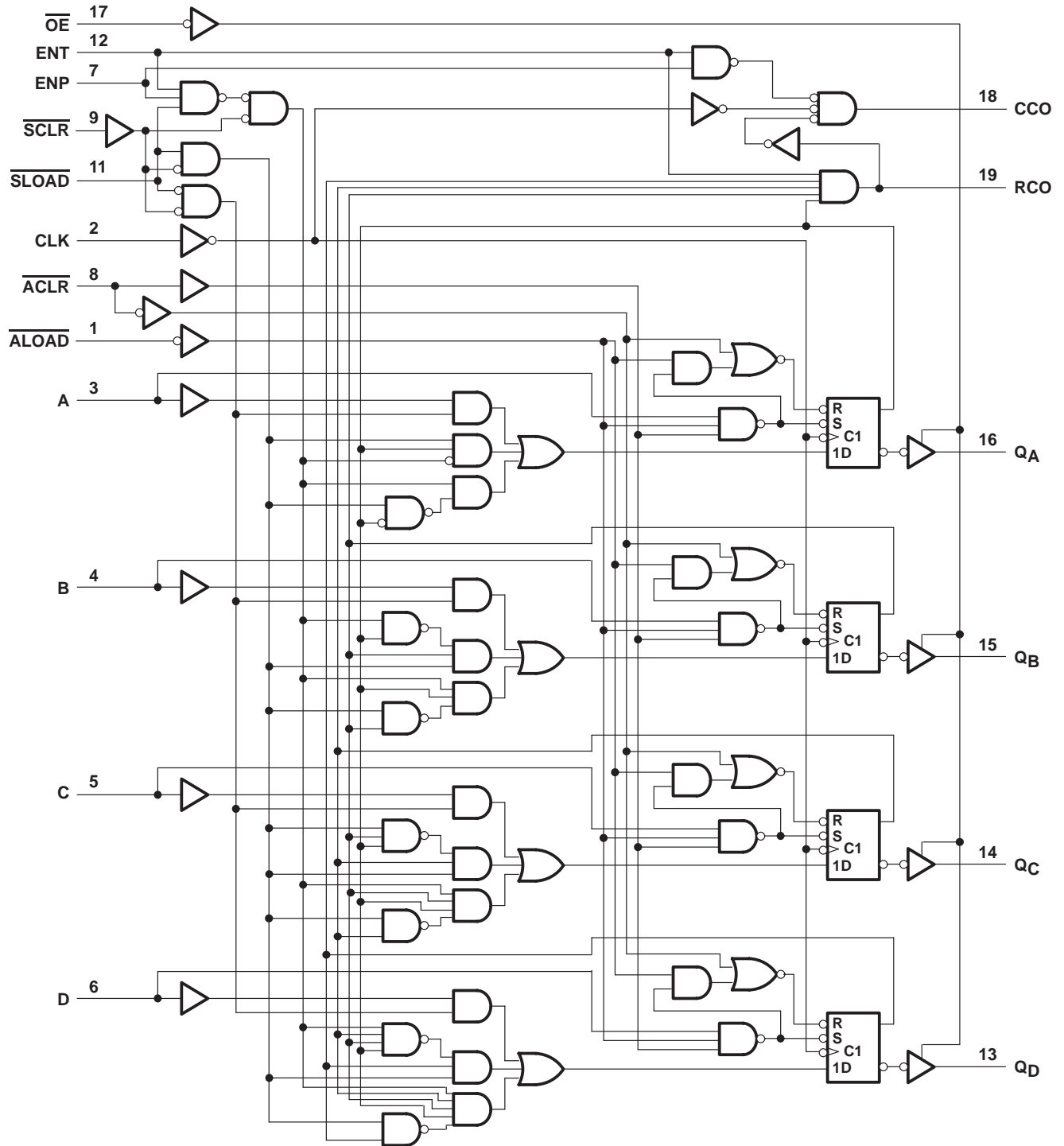

SN54ALS561A, SN74ALS561A SYNCHRONOUS 4-BIT COUNTERS WITH 3-STATE OUTPUTS

SDAS225A – DECEMBER 1982 – REVISED JANUARY 1995

typical load, count, and inhibit sequences

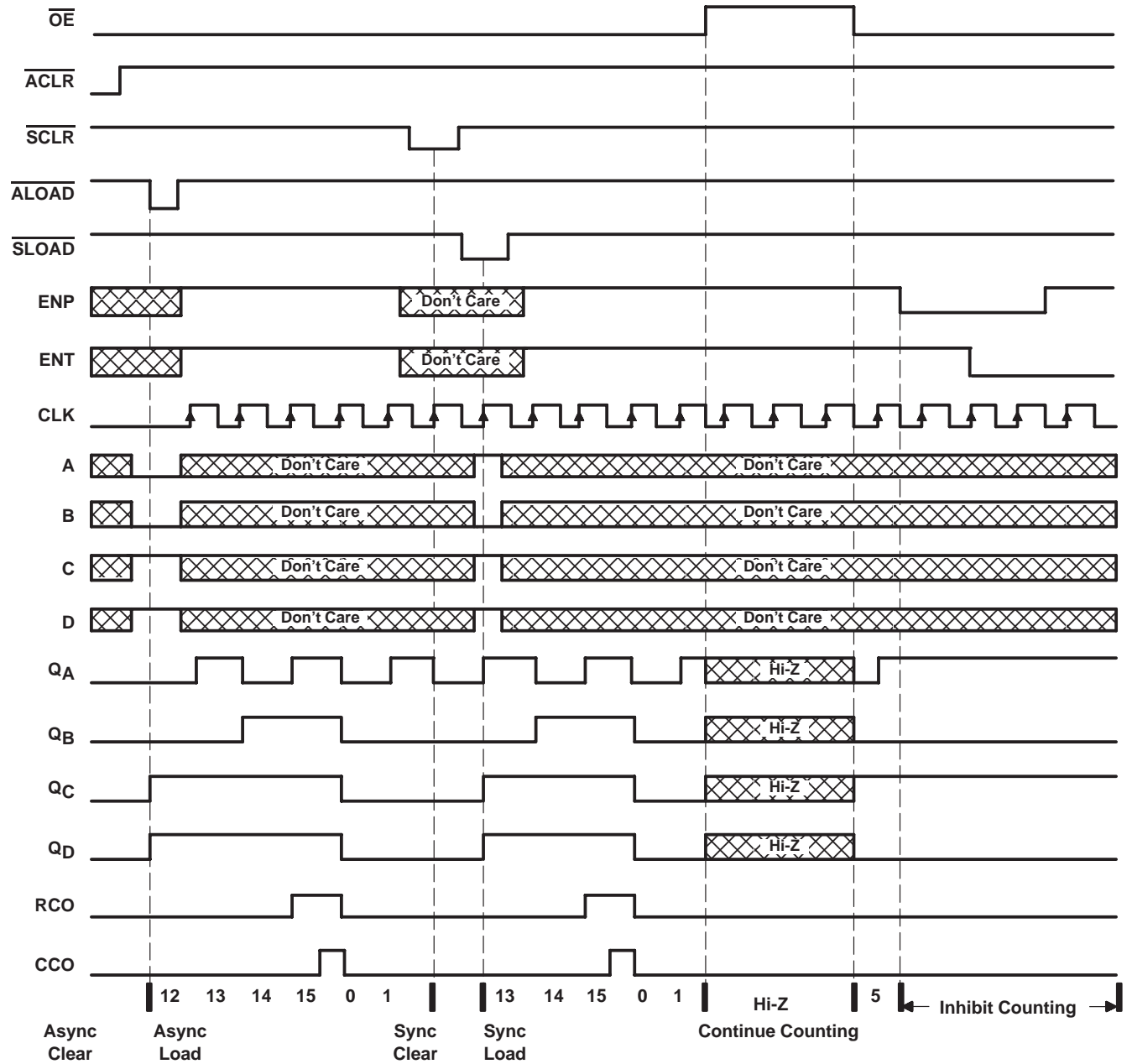

SN54ALS561A, SN74ALS561A SYNCHRONOUS 4-BIT COUNTERS WITH 3-STATE OUTPUTS

SDAS225A – DECEMBER 1982 – REVISED JANUARY 1995

absolute maximum ratings over operating free-air temperature range (unless otherwise noted)†

Supply voltage, V_{CC}	7 V
Input voltage, V_I	7 V
Operating free-air temperature range, T_A : SN54ALS561A	–55°C to 125°C
SN74ALS561A	0°C to 70°C
Storage temperature range	–65°C to 150°C

† Stresses beyond those listed under “absolute maximum ratings” may cause permanent damage to the device. These are stress ratings only, and functional operation of the device at these or any other conditions beyond those indicated under “recommended operating conditions” is not implied. Exposure to absolute-maximum-rated conditions for extended periods may affect device reliability.

recommended operating conditions

		SN54ALS561A			SN74ALS561A			UNIT
		MIN	NOM	MAX	MIN	NOM	MAX	
V_{CC}	Supply voltage	4.5	5	5.5	4.5	5	5.5	V
V_{IH}	High-level input voltage	2			2			V
V_{IL}	Low-level input voltage			0.7			0.8	V
I_{OH}	High-level output current	Q outputs		–1	–2.6		mA	
		CCO and RCO		–0.4	–0.4			
I_{OL}	Low-level output current	Q outputs		12	24		mA	
		CCO and RCO		4	8			
f_{clock}	Clock frequency	0		20	0		30	MHz
t_w	Pulse duration	$\overline{ACL R}$ or $\overline{AL O A D}$ low		20	15		ns	
		CLK high		20	16.5			
		CLK low		25	16.5			
t_{su}	Setup time before $CLK\uparrow$	ENP, ENT	High	25	20		ns	
			Low	25	20			
		Data at A, B, C, D		25	20			
		$\overline{SCL R}$	Low	21	15			
			High (inactive)	35	30			
		$\overline{SLO A D}$	Low	20	15			
			High (inactive)	35	30			
$\overline{ACL R}$ or $\overline{AL O A D}$ inactive		12	10					
t_h	Hold time after $CLK\uparrow$ for data, ENP, ENT, $\overline{SCL R}$, or $\overline{SLO A D}$	0			0			ns
T_A	Operating free-air temperature	–55		125	0		70	°C



SN54ALS561A, SN74ALS561A
SYNCHRONOUS 4-BIT COUNTERS
WITH 3-STATE OUTPUTS

SDAS225A – DECEMBER 1982 – REVISED JANUARY 1995

electrical characteristics over recommended operating free-air temperature range (unless otherwise noted)

PARAMETER		TEST CONDITIONS		SN54ALS561A		SN74ALS561A		UNIT
				MIN	TYP†	MAX	MIN	
V_{IK}		$V_{CC} = 4.5\text{ V}$,	$I_I = -18\text{ mA}$	-1.5		-1.5		V
V_{OH}	All outputs	$V_{CC} = 4.5\text{ V to } 5.5\text{ V}$,	$I_{OH} = -0.4\text{ mA}$	$V_{CC} - 2$		$V_{CC} - 2$		V
	Q outputs	$V_{CC} = 4.5\text{ V}$	$I_{OH} = -1\text{ mA}$	2.4	3.3			
V_{OL}	Q outputs	$V_{CC} = 4.5\text{ V}$	$I_{OL} = 12\text{ mA}$	0.25	0.4	0.25	0.4	V
			$I_{OL} = 24\text{ mA}$			0.35	0.5	
	CCO and RCO	$V_{CC} = 4.5\text{ V}$	$I_{OL} = 4\text{ mA}$	0.25	0.4	0.25	0.4	
			$I_{OL} = 8\text{ mA}$			0.35	0.5	
I_{OZH}		$V_{CC} = 5.5\text{ V}$,	$V_O = 2.7\text{ V}$	20		20		μA
I_{OZL}		$V_{CC} = 5.5\text{ V}$,	$V_O = 0.4\text{ V}$	-20		-20		μA
I_I	ENP and ENT	$V_{CC} = 5.5\text{ V}$,	$V_I = 7\text{ V}$	0.2		0.2		mA
	Other inputs			0.1		0.1		
I_{IH}	ENP and ENT	$V_{CC} = 5.5\text{ V}$,	$V_I = 2.7\text{ V}$	40		40		μA
	Other inputs			20		20		
I_{IL}		$V_{CC} = 5.5\text{ V}$,	$V_I = 0.4\text{ V}$	-0.2		-0.2		mA
$I_{O\ddagger}$	CCO and RCO	$V_{CC} = 5.5\text{ V}$,	$V_O = 2.25\text{ V}$	-15	-70	-15	-70	mA
	Q			-20	-112	-30	-112	
I_{CC}	$V_{CC} = 5.5\text{ V}$		Outputs high	17	27	17	27	mA
			Outputs low	21	33	21	33	
			Outputs disabled	22	36	22	36	

† All typical values are at $V_{CC} = 5\text{ V}$, $T_A = 25^\circ\text{C}$.

‡ The output conditions have been chosen to produce a current that closely approximates one half of the true short-circuit output current, I_{OS} .

SN54ALS561A, SN74ALS561A SYNCHRONOUS 4-BIT COUNTERS WITH 3-STATE OUTPUTS

SDAS225A – DECEMBER 1982 – REVISED JANUARY 1995

switching characteristics (see Figure 1)

PARAMETER	FROM (INPUT)	TO (OUTPUT)	V _{CC} = 4.5 V to 5.5 V, C _L = 50 pF, R ₁ = 500 Ω, R ₂ = 500 Ω, T _A = MIN to MAX†				UNIT
			SN54ALS561A		SN74ALS561A		
			MIN	MAX	MIN	MAX	
f _{max}			20		30		MHz
t _{PLH}	CLK	Any Q	4	15	4	12	ns
t _{PHL}			5	21	5	18	
t _{PLH}	CLK	RCO	9	35	9	29	ns
t _{PHL}			8	29	8	24	
t _{PLH}	CLK	CCO	8	35	8	26	ns
t _{PHL}			5	20	5	16	
t _{PLH}	$\overline{\text{ALOAD}}$	Any Q	10	38	10	35	ns
t _{PHL}			7	27	7	23	
t _{PLH}	$\overline{\text{ALOAD}}$	RCO	15	50	15	40	ns
t _{PHL}			12	35	12	30	
t _{PLH}	$\overline{\text{ALOAD}}$	CCO	25	65	25	55	ns
t _{PHL}			12	42	12	33	
t _{PLH}	A, B, C, or D	Any Q	8	35	8	30	ns
t _{PHL}			7	27	7	22	
t _{PLH}	ENT	RCO	5	20	5	16	ns
t _{PHL}			4	18	4	14	
t _{PLH}	ENT	CCO	12	35	12	32	ns
t _{PHL}			4	15	4	12	
t _{PLH}	ENP	CCO	5	22	5	18	ns
t _{PHL}			4	14	4	12	
t _{PHL}	$\overline{\text{ACLR}}$	Any Q	7	28	7	22	ns
t _{PZH}	$\overline{\text{OE}}$	Any Q	5	24	5	19	ns
t _{PZL}			8	28	8	23	
t _{PHZ}	$\overline{\text{OE}}$	Any Q	2	12	2	10	ns
t _{PLZ}			2	20	4	15	

† For conditions shown as MIN or MAX, use the appropriate value specified under recommended operating conditions.

SN54ALS561A, SN74ALS561A SYNCHRONOUS 4-BIT COUNTERS WITH 3-STATE OUTPUTS

SDAS225A – DECEMBER 1982 – REVISED JANUARY 1995

PARAMETER MEASUREMENT INFORMATION SERIES 54ALS/74ALS AND 54AS/74AS DEVICES

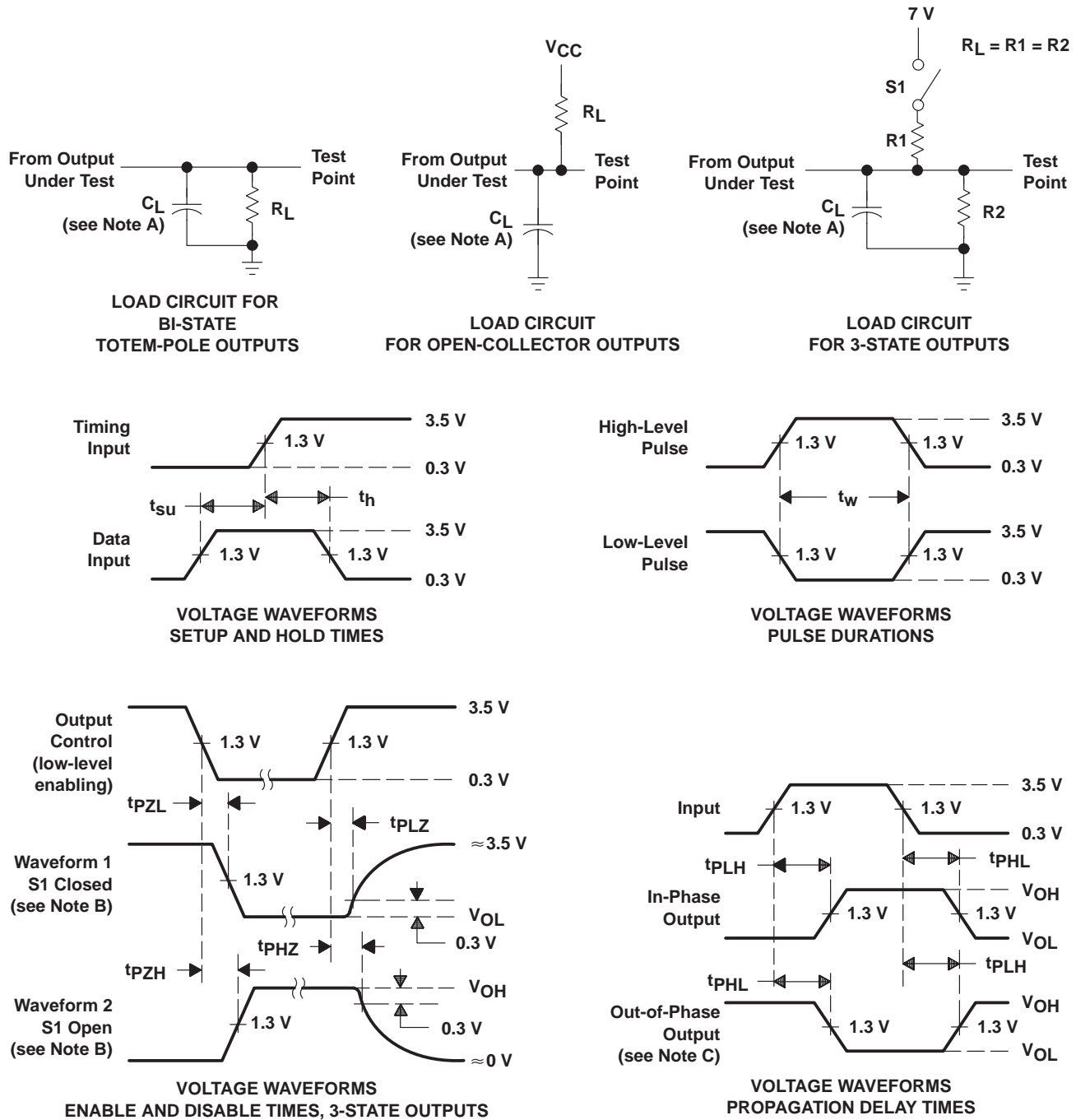

- NOTES: A. C_L includes probe and jig capacitance.
 B. Waveform 1 is for an output with internal conditions such that the output is low except when disabled by the output control. Waveform 2 is for an output with internal conditions such that the output is high except when disabled by the output control.
 C. When measuring propagation delay items of 3-state outputs, switch S1 is open.
 D. All input pulses have the following characteristics: $PRR \leq 1$ MHz, $t_r = t_f = 2$ ns, duty cycle = 50%.
 E. The outputs are measured one at a time with one transition per measurement.

Figure 1. Load Circuits and Voltage Waveforms

PACKAGING INFORMATION

Orderable Device	Status (1)	Package Type	Package Drawing	Pins	Package Qty	Eco Plan (2)	Lead finish/ Ball material (6)	MSL Peak Temp (3)	Op Temp (°C)	Device Marking (4/5)	Samples
SN74ALS561AN	ACTIVE	PDIP	N	20	20	RoHS & Non-Green	NIPDAU	N / A for Pkg Type	0 to 70	SN74ALS561AN	Samples
SN74ALS561ANE4	ACTIVE	PDIP	N	20	20	TBD	Call TI	Call TI	0 to 70		Samples

(1) The marketing status values are defined as follows:

ACTIVE: Product device recommended for new designs.

LIFEBUY: TI has announced that the device will be discontinued, and a lifetime-buy period is in effect.

NRND: Not recommended for new designs. Device is in production to support existing customers, but TI does not recommend using this part in a new design.

PREVIEW: Device has been announced but is not in production. Samples may or may not be available.

OBSELETE: TI has discontinued the production of the device.

(2) **RoHS:** TI defines "RoHS" to mean semiconductor products that are compliant with the current EU RoHS requirements for all 10 RoHS substances, including the requirement that RoHS substance do not exceed 0.1% by weight in homogeneous materials. Where designed to be soldered at high temperatures, "RoHS" products are suitable for use in specified lead-free processes. TI may reference these types of products as "Pb-Free".

RoHS Exempt: TI defines "RoHS Exempt" to mean products that contain lead but are compliant with EU RoHS pursuant to a specific EU RoHS exemption.

Green: TI defines "Green" to mean the content of Chlorine (Cl) and Bromine (Br) based flame retardants meet JS709B low halogen requirements of <=1000ppm threshold. Antimony trioxide based flame retardants must also meet the <=1000ppm threshold requirement.

(3) MSL, Peak Temp. - The Moisture Sensitivity Level rating according to the JEDEC industry standard classifications, and peak solder temperature.

(4) There may be additional marking, which relates to the logo, the lot trace code information, or the environmental category on the device.

(5) Multiple Device Markings will be inside parentheses. Only one Device Marking contained in parentheses and separated by a "-" will appear on a device. If a line is indented then it is a continuation of the previous line and the two combined represent the entire Device Marking for that device.

(6) Lead finish/Ball material - Orderable Devices may have multiple material finish options. Finish options are separated by a vertical ruled line. Lead finish/Ball material values may wrap to two lines if the finish value exceeds the maximum column width.

Important Information and Disclaimer:The information provided on this page represents TI's knowledge and belief as of the date that it is provided. TI bases its knowledge and belief on information provided by third parties, and makes no representation or warranty as to the accuracy of such information. Efforts are underway to better integrate information from third parties. TI has taken and continues to take reasonable steps to provide representative and accurate information but may not have conducted destructive testing or chemical analysis on incoming materials and chemicals. TI and TI suppliers consider certain information to be proprietary, and thus CAS numbers and other limited information may not be available for release.

In no event shall TI's liability arising out of such information exceed the total purchase price of the TI part(s) at issue in this document sold by TI to Customer on an annual basis.

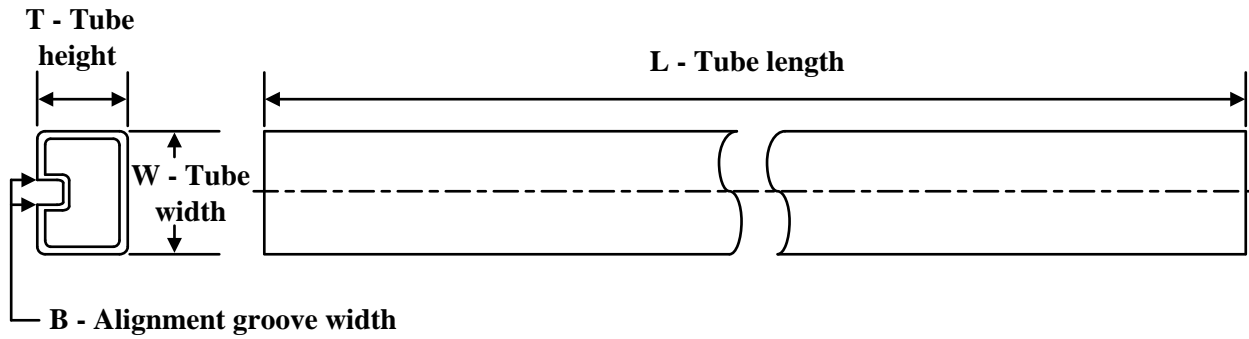
TUBE

*All dimensions are nominal

Device	Package Name	Package Type	Pins	SPQ	L (mm)	W (mm)	T (μm)	B (mm)
SN74ALS561AN	N	PDIP	20	20	506	13.97	11230	4.32

N (R-PDIP-T**)

PLASTIC DUAL-IN-LINE PACKAGE

16 PINS SHOWN



- NOTES:
- A. All linear dimensions are in inches (millimeters).
 - B. This drawing is subject to change without notice.
 - Falls within JEDEC MS-001, except 18 and 20 pin minimum body length (Dim A).
 - The 20 pin end lead shoulder width is a vendor option, either half or full width.

IMPORTANT NOTICE AND DISCLAIMER

TI PROVIDES TECHNICAL AND RELIABILITY DATA (INCLUDING DATA SHEETS), DESIGN RESOURCES (INCLUDING REFERENCE DESIGNS), APPLICATION OR OTHER DESIGN ADVICE, WEB TOOLS, SAFETY INFORMATION, AND OTHER RESOURCES "AS IS" AND WITH ALL FAULTS, AND DISCLAIMS ALL WARRANTIES, EXPRESS AND IMPLIED, INCLUDING WITHOUT LIMITATION ANY IMPLIED WARRANTIES OF MERCHANTABILITY, FITNESS FOR A PARTICULAR PURPOSE OR NON-INFRINGEMENT OF THIRD PARTY INTELLECTUAL PROPERTY RIGHTS.

These resources are intended for skilled developers designing with TI products. You are solely responsible for (1) selecting the appropriate TI products for your application, (2) designing, validating and testing your application, and (3) ensuring your application meets applicable standards, and any other safety, security, regulatory or other requirements.

These resources are subject to change without notice. TI grants you permission to use these resources only for development of an application that uses the TI products described in the resource. Other reproduction and display of these resources is prohibited. No license is granted to any other TI intellectual property right or to any third party intellectual property right. TI disclaims responsibility for, and you will fully indemnify TI and its representatives against, any claims, damages, costs, losses, and liabilities arising out of your use of these resources.

TI's products are provided subject to [TI's Terms of Sale](#) or other applicable terms available either on ti.com or provided in conjunction with such TI products. TI's provision of these resources does not expand or otherwise alter TI's applicable warranties or warranty disclaimers for TI products.

TI objects to and rejects any additional or different terms you may have proposed.

Mailing Address: Texas Instruments, Post Office Box 655303, Dallas, Texas 75265
Copyright © 2022, Texas Instruments Incorporated