

SN54ALS561A, SN74ALS561A SYNCHRONOUS 4-BIT COUNTERS WITH 3-STATE OUTPUTS

SDAS225A – DECEMBER 1982 – REVISED JANUARY 1995

- Carry Output for n-Bit Cascading
- Buffer-Type Outputs Drive Bus Lines Directly
- Choice of Asynchronous or Synchronous Clearing and Loading
- Internal Look-Ahead Circuitry for Fast Cascading
- Package Options Include Plastic Small-Outline (DW) Packages, Ceramic Chip Carriers (FK), and Standard Plastic (N) and Ceramic (J) 300-mil DIPs

description

These binary counters are programmable and offer synchronous and asynchronous clearing as well as synchronous and asynchronous loading. All synchronous functions are executed on the positive-going edge of the clock.

The clear function is initiated by applying a low level to either asynchronous clear ($\overline{\text{ACLR}}$) or synchronous clear (SCLR). $\overline{\text{ACLR}}$ (direct clear) overrides all other functions of the device, while SCLR overrides only the other synchronous functions. Data is loaded from the A, B, C, and D inputs by applying a low level to asynchronous load ($\overline{\text{ALOAD}}$) or by the combination of a low level at synchronous load ($\overline{\text{SLOAD}}$) and a positive-going clock transition. The counting function is enabled only when enable P (ENP), enable T (ENT), $\overline{\text{ACLR}}$, $\overline{\text{ALOAD}}$, SCLR , and $\overline{\text{SLOAD}}$ are all high.

A high level at the output-enable ($\overline{\text{OE}}$) input forces the Q outputs into the high-impedance state, and a low level enables those outputs. Counting is independent of $\overline{\text{OE}}$. ENT is fed forward to enable the ripple-carry output (RCO) to produce a high-level pulse while the count is maximum (15). The clocked carry output (CCO) produces a high-level pulse for a duration equal to that of the low level of the clock when RCO is high and the counter is enabled (ENP and ENT are high); otherwise, CCO is low. CCO does not have the glitches commonly associated with a ripple-carry output. Cascading is normally accomplished by connecting RCO or CCO of the first counter to ENT of the next counter. However, for very high-speed counting, RCO should be used for cascading because CCO does not become active until the clock returns to the low level.

The SN54ALS561A is characterized for operation over the full military temperature range of -55°C to 125°C . The SN74ALS561A is characterized for operation from 0°C to 70°C .

SN54ALS561A . . . J PACKAGE
SN74ALS561A . . . DW OR N PACKAGE
(TOP VIEW)

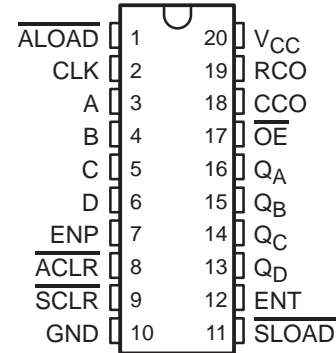

SN54ALS561A . . . FK PACKAGE
(TOP VIEW)

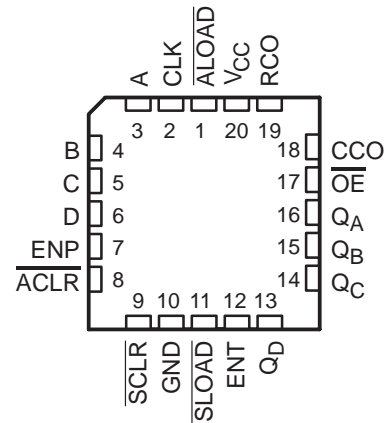

SN54ALS561A, SN74ALS561A SYNCHRONOUS 4-BIT COUNTERS WITH 3-STATE OUTPUTS

SDAS225A – DECEMBER 1982 – REVISED JANUARY 1995

FUNCTION TABLE

INPUTS								OPERATION
\overline{OE}	\overline{ACLR}	\overline{ALOAD}	\overline{SCLR}	\overline{SLOAD}	ENT	ENP	CLK	
H	X	X	X	X	X	X	X	Q outputs disabled
L	L	X	X	X	X	X	X	Asynchronous clear
L	H	L	X	X	X	X	X	Asynchronous load
L	H	H	L	X	X	X	↑	Synchronous clear
L	H	H	H	L	X	X	↑	Synchronous load
L	H	H	H	H	H	H	↑	Count
L	H	H	H	H	L	X	X	Inhibit counting
L	H	H	H	H	X	L	X	Inhibit counting

logic symbol†

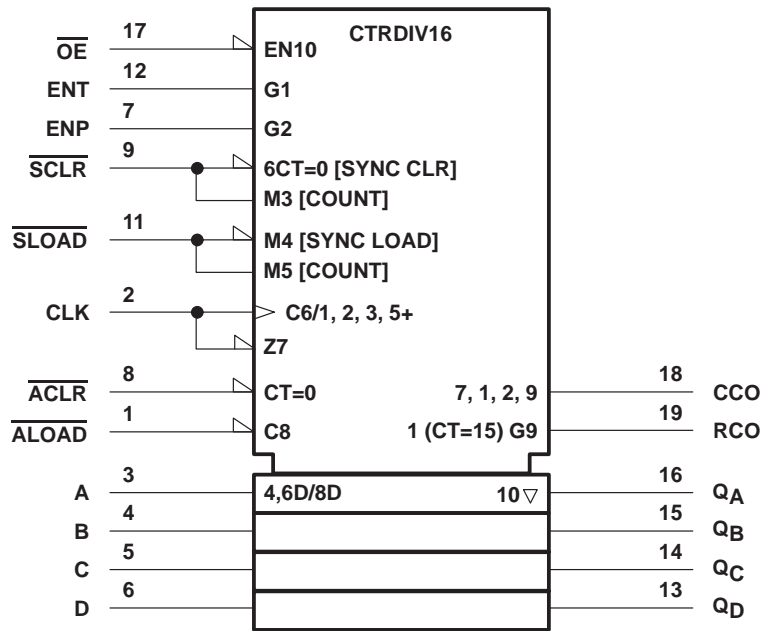

† This symbol is in accordance with ANSI/IEEE Std 91-1984 and IEC Publication 617-12.

SN54ALS561A, SN74ALS561A
 SYNCHRONOUS 4-BIT COUNTERS
 WITH 3-STATE OUTPUTS

SDAS225A – DECEMBER 1982 – REVISED JANUARY 1995

logic diagram (positive logic)

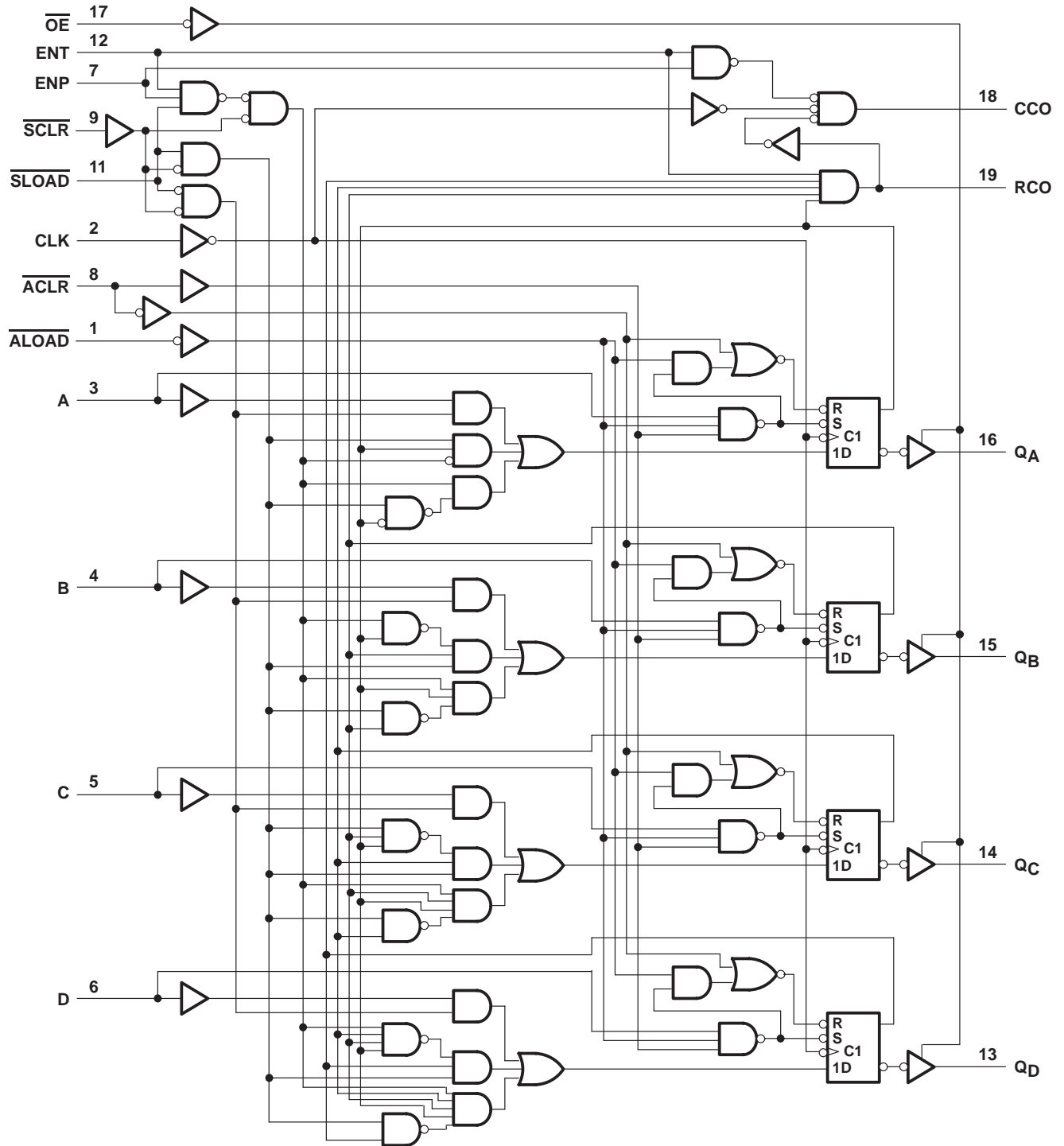

SN54ALS561A, SN74ALS561A SYNCHRONOUS 4-BIT COUNTERS WITH 3-STATE OUTPUTS

SDAS225A – DECEMBER 1982 – REVISED JANUARY 1995

typical load, count, and inhibit sequences

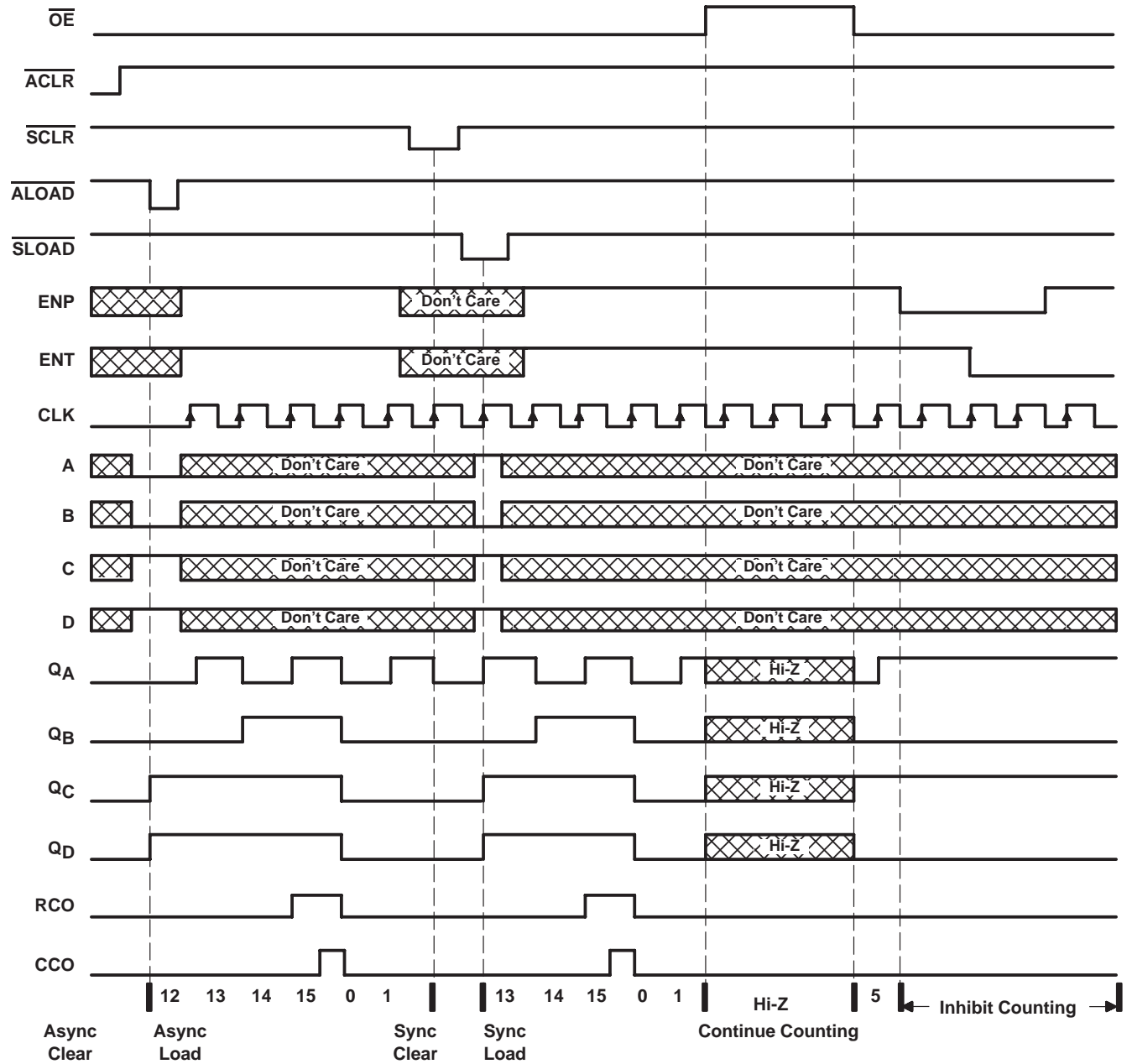

SN54ALS561A, SN74ALS561A SYNCHRONOUS 4-BIT COUNTERS WITH 3-STATE OUTPUTS

SDAS225A – DECEMBER 1982 – REVISED JANUARY 1995

absolute maximum ratings over operating free-air temperature range (unless otherwise noted)†

Supply voltage, V_{CC}	7 V
Input voltage, V_I	7 V
Operating free-air temperature range, T_A : SN54ALS561A	–55°C to 125°C
SN74ALS561A	0°C to 70°C
Storage temperature range	–65°C to 150°C

† Stresses beyond those listed under “absolute maximum ratings” may cause permanent damage to the device. These are stress ratings only, and functional operation of the device at these or any other conditions beyond those indicated under “recommended operating conditions” is not implied. Exposure to absolute-maximum-rated conditions for extended periods may affect device reliability.

recommended operating conditions

		SN54ALS561A			SN74ALS561A			UNIT
		MIN	NOM	MAX	MIN	NOM	MAX	
V_{CC}	Supply voltage	4.5	5	5.5	4.5	5	5.5	V
V_{IH}	High-level input voltage	2			2			V
V_{IL}	Low-level input voltage			0.7			0.8	V
I_{OH}	High-level output current	Q outputs		–1	–2.6		mA	
		CCO and RCO		–0.4	–0.4			
I_{OL}	Low-level output current	Q outputs		12	24		mA	
		CCO and RCO		4	8			
f_{clock}	Clock frequency	0		20	0		30	MHz
t_w	Pulse duration	$\overline{ACL R}$ or $\overline{AL O A D}$ low		20	15		ns	
		CLK high		20	16.5			
		CLK low		25	16.5			
t_{su}	Setup time before $CLK\uparrow$	ENP, ENT	High	25	20		ns	
			Low	25	20			
		Data at A, B, C, D		25	20			
		$\overline{SCL R}$	Low	21	15			
			High (inactive)	35	30			
		$\overline{SLO A D}$	Low	20	15			
			High (inactive)	35	30			
$\overline{ACL R}$ or $\overline{AL O A D}$ inactive		12	10					
t_h	Hold time after $CLK\uparrow$ for data, ENP, ENT, $\overline{SCL R}$, or $\overline{SLO A D}$	0			0			ns
T_A	Operating free-air temperature	–55		125	0		70	°C



SN54ALS561A, SN74ALS561A
SYNCHRONOUS 4-BIT COUNTERS
WITH 3-STATE OUTPUTS

SDAS225A – DECEMBER 1982 – REVISED JANUARY 1995

electrical characteristics over recommended operating free-air temperature range (unless otherwise noted)

PARAMETER		TEST CONDITIONS		SN54ALS561A		SN74ALS561A		UNIT	
				MIN	TYP†	MAX	MIN		TYP†
V_{IK}		$V_{CC} = 4.5\text{ V}$, $I_I = -18\text{ mA}$		-1.5		-1.5		V	
V_{OH}	All outputs	$V_{CC} = 4.5\text{ V to } 5.5\text{ V}$, $I_{OH} = -0.4\text{ mA}$		$V_{CC} - 2$		$V_{CC} - 2$		V	
	Q outputs	$V_{CC} = 4.5\text{ V}$		2.4	3.3	2.4	3.2		
V_{OL}	Q outputs	$V_{CC} = 4.5\text{ V}$		$I_{OL} = 12\text{ mA}$		0.25	0.4	0.25	0.4
				$I_{OL} = 24\text{ mA}$		0.35		0.5	
	CCO and RCO	$V_{CC} = 4.5\text{ V}$		$I_{OL} = 4\text{ mA}$		0.25	0.4	0.25	0.4
				$I_{OL} = 8\text{ mA}$		0.35		0.5	
I_{OZH}		$V_{CC} = 5.5\text{ V}$, $V_O = 2.7\text{ V}$		20		20		μA	
I_{OZL}		$V_{CC} = 5.5\text{ V}$, $V_O = 0.4\text{ V}$		-20		-20		μA	
I_I	ENP and ENT	$V_{CC} = 5.5\text{ V}$, $V_I = 7\text{ V}$		0.2		0.2		mA	
	Other inputs			0.1		0.1			
I_{IH}	ENP and ENT	$V_{CC} = 5.5\text{ V}$, $V_I = 2.7\text{ V}$		40		40		μA	
	Other inputs			20		20			
I_{IL}		$V_{CC} = 5.5\text{ V}$, $V_I = 0.4\text{ V}$		-0.2		-0.2		mA	
$I_{O\ddagger}$	CCO and RCO	$V_{CC} = 5.5\text{ V}$, $V_O = 2.25\text{ V}$		-15	-70	-15	-70	mA	
	Q			-20	-112	-30	-112		
I_{CC}	$V_{CC} = 5.5\text{ V}$		Outputs high		17	27	17	27	mA
			Outputs low		21	33	21	33	
			Outputs disabled		22	36	22	36	

† All typical values are at $V_{CC} = 5\text{ V}$, $T_A = 25^\circ\text{C}$.

‡ The output conditions have been chosen to produce a current that closely approximates one half of the true short-circuit output current, I_{OS} .



SN54ALS561A, SN74ALS561A SYNCHRONOUS 4-BIT COUNTERS WITH 3-STATE OUTPUTS

SDAS225A – DECEMBER 1982 – REVISED JANUARY 1995

switching characteristics (see Figure 1)

PARAMETER	FROM (INPUT)	TO (OUTPUT)	V _{CC} = 4.5 V to 5.5 V, C _L = 50 pF, R ₁ = 500 Ω, R ₂ = 500 Ω, T _A = MIN to MAX†				UNIT
			SN54ALS561A		SN74ALS561A		
			MIN	MAX	MIN	MAX	
f _{max}			20		30		MHz
t _{PLH}	CLK	Any Q	4	15	4	12	ns
t _{PHL}			5	21	5	18	
t _{PLH}	CLK	RCO	9	35	9	29	ns
t _{PHL}			8	29	8	24	
t _{PLH}	CLK	CCO	8	35	8	26	ns
t _{PHL}			5	20	5	16	
t _{PLH}	$\overline{\text{ALOAD}}$	Any Q	10	38	10	35	ns
t _{PHL}			7	27	7	23	
t _{PLH}	$\overline{\text{ALOAD}}$	RCO	15	50	15	40	ns
t _{PHL}			12	35	12	30	
t _{PLH}	$\overline{\text{ALOAD}}$	CCO	25	65	25	55	ns
t _{PHL}			12	42	12	33	
t _{PLH}	A, B, C, or D	Any Q	8	35	8	30	ns
t _{PHL}			7	27	7	22	
t _{PLH}	ENT	RCO	5	20	5	16	ns
t _{PHL}			4	18	4	14	
t _{PLH}	ENT	CCO	12	35	12	32	ns
t _{PHL}			4	15	4	12	
t _{PLH}	ENP	CCO	5	22	5	18	ns
t _{PHL}			4	14	4	12	
t _{PHL}	$\overline{\text{ACLR}}$	Any Q	7	28	7	22	ns
t _{PZH}	$\overline{\text{OE}}$	Any Q	5	24	5	19	ns
t _{PZL}			8	28	8	23	
t _{PHZ}	$\overline{\text{OE}}$	Any Q	2	12	2	10	ns
t _{PLZ}			2	20	4	15	

† For conditions shown as MIN or MAX, use the appropriate value specified under recommended operating conditions.

SN54ALS561A, SN74ALS561A SYNCHRONOUS 4-BIT COUNTERS WITH 3-STATE OUTPUTS

SDAS225A – DECEMBER 1982 – REVISED JANUARY 1995

PARAMETER MEASUREMENT INFORMATION SERIES 54ALS/74ALS AND 54AS/74AS DEVICES

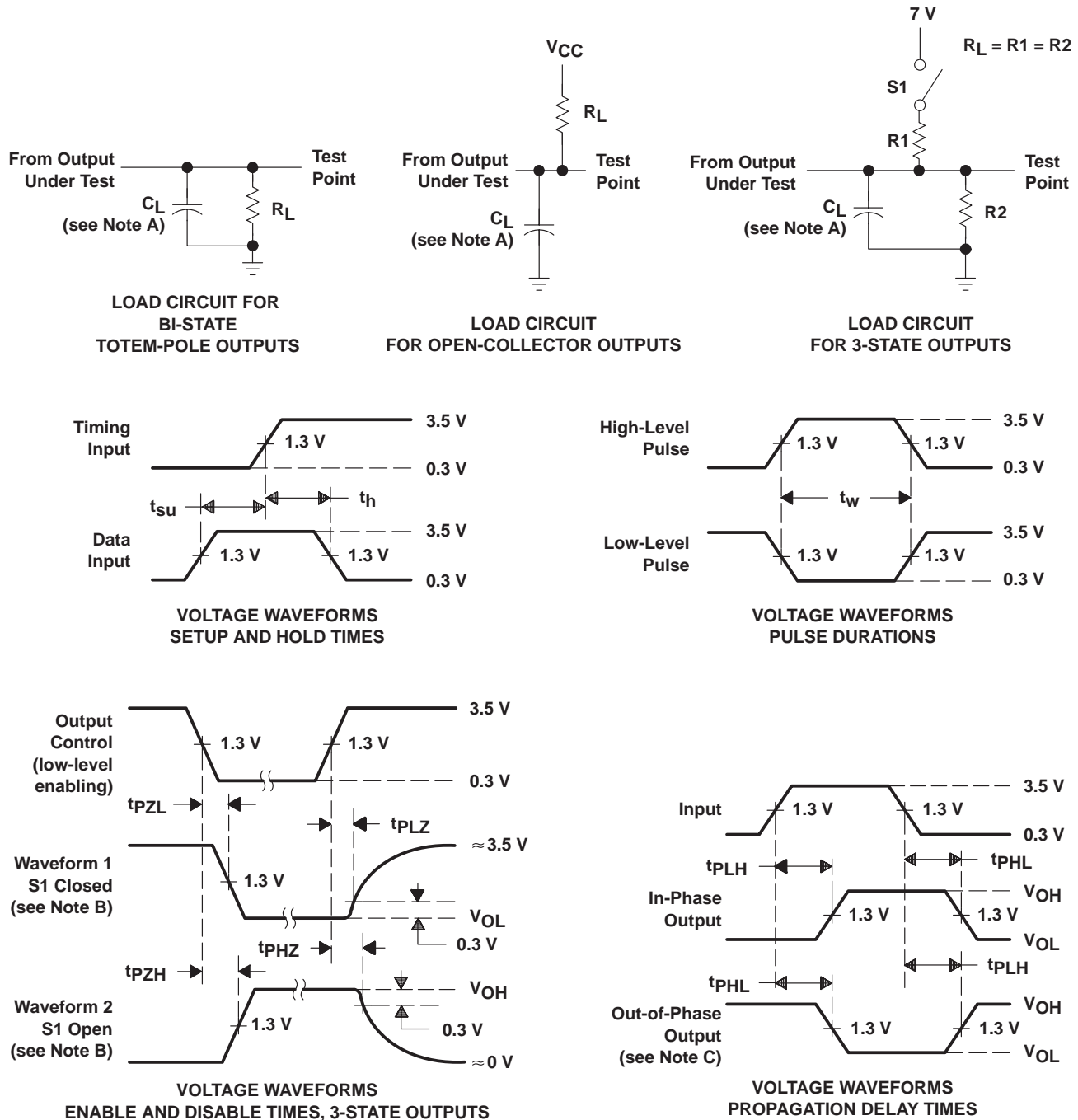

- NOTES: A. C_L includes probe and jig capacitance.
 B. Waveform 1 is for an output with internal conditions such that the output is low except when disabled by the output control. Waveform 2 is for an output with internal conditions such that the output is high except when disabled by the output control.
 C. When measuring propagation delay items of 3-state outputs, switch S1 is open.
 D. All input pulses have the following characteristics: $PRR \leq 1$ MHz, $t_r = t_f = 2$ ns, duty cycle = 50%.
 E. The outputs are measured one at a time with one transition per measurement.

Figure 1. Load Circuits and Voltage Waveforms

IMPORTANT NOTICE

Texas Instruments and its subsidiaries (TI) reserve the right to make changes to their products or to discontinue any product or service without notice, and advise customers to obtain the latest version of relevant information to verify, before placing orders, that information being relied on is current and complete. All products are sold subject to the terms and conditions of sale supplied at the time of order acknowledgement, including those pertaining to warranty, patent infringement, and limitation of liability.

TI warrants performance of its semiconductor products to the specifications applicable at the time of sale in accordance with TI's standard warranty. Testing and other quality control techniques are utilized to the extent TI deems necessary to support this warranty. Specific testing of all parameters of each device is not necessarily performed, except those mandated by government requirements.

CERTAIN APPLICATIONS USING SEMICONDUCTOR PRODUCTS MAY INVOLVE POTENTIAL RISKS OF DEATH, PERSONAL INJURY, OR SEVERE PROPERTY OR ENVIRONMENTAL DAMAGE ("CRITICAL APPLICATIONS"). TI SEMICONDUCTOR PRODUCTS ARE NOT DESIGNED, AUTHORIZED, OR WARRANTED TO BE SUITABLE FOR USE IN LIFE-SUPPORT DEVICES OR SYSTEMS OR OTHER CRITICAL APPLICATIONS. INCLUSION OF TI PRODUCTS IN SUCH APPLICATIONS IS UNDERSTOOD TO BE FULLY AT THE CUSTOMER'S RISK.

In order to minimize risks associated with the customer's applications, adequate design and operating safeguards must be provided by the customer to minimize inherent or procedural hazards.

TI assumes no liability for applications assistance or customer product design. TI does not warrant or represent that any license, either express or implied, is granted under any patent right, copyright, mask work right, or other intellectual property right of TI covering or relating to any combination, machine, or process in which such semiconductor products or services might be or are used. TI's publication of information regarding any third party's products or services does not constitute TI's approval, warranty or endorsement thereof.