

SN54ALS29821, SN74ALS29821 10-BIT BUS-INTERFACE FLIP-FLOPS WITH 3-STATE OUTPUTS

SDAS145B – JANUARY 1986 – REVISED JANUARY 1995

- Functionally Equivalent to AMD's AM29821
- Provide Extra Data Width Necessary for Wider Address/Data Paths or Buses With Parity
- Outputs Have Undershoot-Protection Circuitry
- Power-Up High-Impedance State
- Buffered Control Inputs Reduce dc Loading Effects
- Package Options Include Plastic Small-Outline (DW) Packages and Standard Plastic (NT) and Ceramic (JT) 300-mil DIPs

SN54ALS29821 . . . JT PACKAGE
SN74ALS29821 . . . DW OR NT PACKAGE
(TOP VIEW)

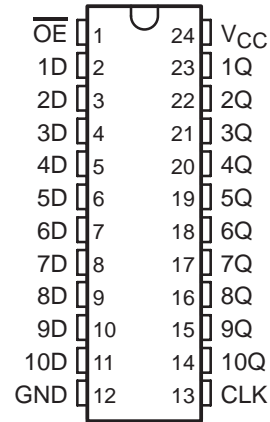

description

These 10-bit edge-triggered D-type flip-flops feature 3-state outputs designed specifically for driving highly capacitive or relatively low-impedance loads. These devices are particularly suitable for implementing wider buffer registers, I/O ports, bidirectional bus drivers with parity, and working registers.

On the positive transition of the clock (CLK) input, the Q outputs are true to the data (D) input.

A buffered output-enable (\overline{OE}) input can place the ten outputs in either a normal logic state (high or low logic levels) or a high-impedance state. The outputs also are in the high-impedance state during power-up and power-down conditions. The outputs remain in the high-impedance state while the device is powered down. In the high-impedance state, the outputs neither load nor drive the bus lines significantly. The high-impedance state and increased drive provide the capability to drive bus lines without interface or pullup components.

\overline{OE} does not affect the internal operation of the flip-flops. Old data can be retained or new data can be entered while the outputs are in the high-impedance state.

The SN54ALS29821 is characterized for operation over the full military temperature range of -55°C to 125°C . The SN74ALS29821 is characterized for operation from 0°C to 70°C .

FUNCTION TABLE
(each flip-flop)

| INPUTS | | | OUTPUT |
|-----------------|------------|---|--------|
| \overline{OE} | CLK | D | Q |
| L | \uparrow | H | H |
| L | \uparrow | L | L |
| L | L | X | Q_0 |
| H | X | X | Z |

SN54ALS29821, SN74ALS29821 10-BIT BUS-INTERFACE FLIP-FLOPS WITH 3-STATE OUTPUTS

SDAS145B – JANUARY 1986 – REVISED JANUARY 1995

logic symbol†

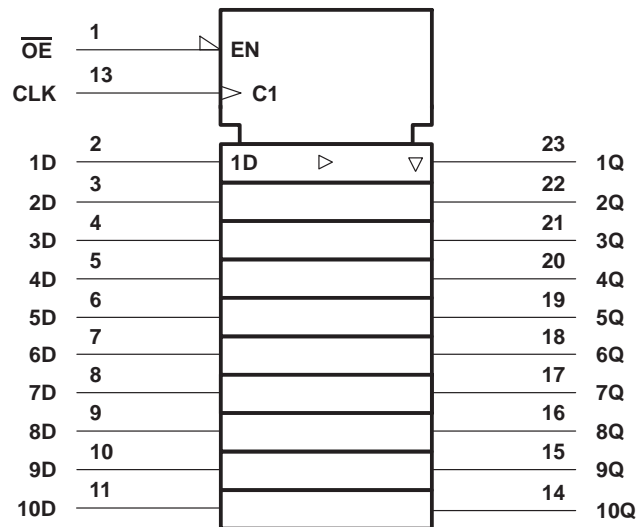

† This symbol is in accordance with ANSI/IEEE Std 91-1984 and IEC Publication 617-12.

logic diagram (positive logic)

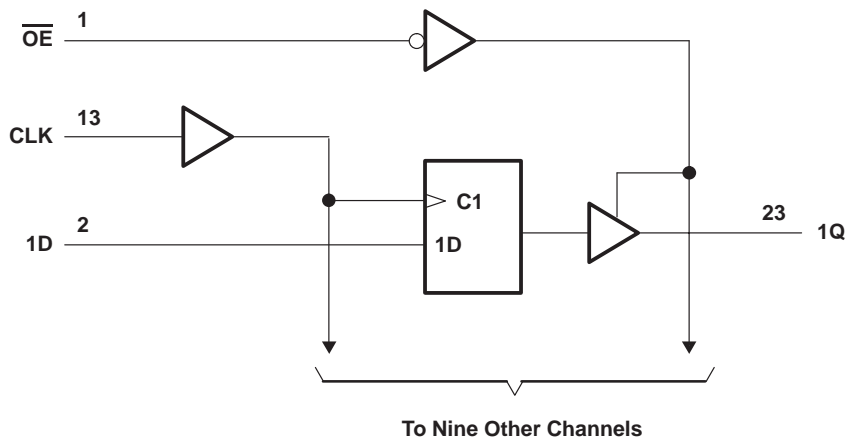

absolute maximum ratings over operating free-air temperature range (unless otherwise noted)‡

| | |
|--|----------------|
| Supply voltage, V_{CC} | 7 V |
| Input voltage, V_I | 5.5 V |
| Voltage applied to a disabled 3-state output | 5.5 V |
| Operating free-air temperature range, T_A : SN54ALS29821 | -55°C to 125°C |
| SN74ALS29821 | 0°C to 70°C |
| Storage temperature range | -65°C to 150°C |

‡ Stresses beyond those listed under "absolute maximum ratings" may cause permanent damage to the device. These are stress ratings only, and functional operation of the device at these or any other conditions beyond those indicated under "recommended operating conditions" is not implied. Exposure to absolute-maximum-rated conditions for extended periods may affect device reliability.



SN54ALS29821, SN74ALS29821 10-BIT BUS-INTERFACE FLIP-FLOPS WITH 3-STATE OUTPUTS

SDAS145B – JANUARY 1986 – REVISED JANUARY 1995

recommended operating conditions

| | | SN54ALS29821 | | | SN74ALS29821 | | | UNIT |
|----------|--|--------------|-----|-----|--------------|-----|------|------|
| | | MIN | NOM | MAX | MIN | NOM | MAX | |
| V_{CC} | Supply voltage | 4.5 | 5 | 5.5 | 4.75 | 5 | 5.25 | V |
| V_{IH} | High-level input voltage | 2 | | | 2 | | | V |
| V_{IL} | Low-level input voltage | | | 0.8 | | | 0.8 | V |
| I_{OH} | High-level output current | | | -24 | | | -24 | mA |
| I_{OL} | Low-level output current | | | 48 | | | 48 | mA |
| t_w | Pulse duration, CLK high or low | 7 | | | 7 | | | ns |
| t_{su} | Setup time, data before CLK \uparrow | 4 | | | 4 | | | ns |
| t_h | Hold time, data after CLK \uparrow | 2 | | | 2 | | | ns |
| T_A | Operating free-air temperature | -55 | | 125 | 0 | | 70 | °C |

electrical characteristics over recommended operating free-air temperature range (unless otherwise noted)

| PARAMETER | TEST CONDITIONS | | SN54ALS29821 | | | SN74ALS29821 | | | UNIT | |
|-------------------|----------------------------|--------------------------|--------------|---------------|------|--------------|---------------|------|------|---------------|
| | | | MIN | TYP \dagger | MAX | MIN | TYP \dagger | MAX | | |
| V_{IK} | $V_{CC} = 4.75\text{ V}$, | $I_I = -18\text{ mA}$ | | | -1.2 | | | -1.2 | V | |
| V_{OH} | $V_{CC} = 4.75\text{ V}$ | $I_{OH} = -15\text{ mA}$ | 2.4 | 3.3 | | 2.4 | 3.3 | | V | |
| | | $I_{OH} = -24\text{ mA}$ | 2 | 3.1 | | 2 | 3.1 | | | |
| V_{OL} | $V_{CC} = 4.75\text{ V}$, | $I_{OL} = 48\text{ mA}$ | | | 0.35 | | | 0.35 | 0.5 | V |
| I_{OZH} | $V_{CC} = 5.25\text{ V}$, | $V_O = 2.4\text{ V}$ | | | 50 | | | 20 | | μA |
| I_{OZL} | $V_{CC} = 5.25\text{ V}$, | $V_O = 0.4\text{ V}$ | | | -50 | | | -20 | | μA |
| I_I | $V_{CC} = 5.25\text{ V}$, | $V_I = 5.5\text{ V}$ | | | 0.1 | | | 0.1 | | mA |
| I_{IH} | $V_{CC} = 5.25\text{ V}$, | $V_I = 2.7\text{ V}$ | | | 20 | | | 20 | | μA |
| I_{IL} | $V_{CC} = 5.25\text{ V}$, | $V_I = 0.4\text{ V}$ | | | -0.5 | | | -0.2 | | mA |
| I_{OS}^\ddagger | $V_{CC} = 5.25\text{ V}$, | $V_O = 0$ | | | -75 | | | -250 | | mA |
| I_{CC} | $V_{CC} = 5.25\text{ V}$, | Outputs open | | | 80 | | | 115 | | mA |

\dagger All typical values are at $V_{CC} = 5\text{ V}$, $T_A = 25^\circ\text{C}$.

\ddagger Not more than one output should be shorted at a time, and the duration of the short circuit should not exceed one second.



SN54ALS29821, SN74ALS29821 10-BIT BUS-INTERFACE FLIP-FLOPS WITH 3-STATE OUTPUTS

SDAS145B – JANUARY 1986 – REVISED JANUARY 1995

switching characteristics (see Figure 1)

| PARAMETER | FROM (INPUT) | TO (OUTPUT) | TEST CONDITIONS | V _{CC} = MIN to MAX†, T _A = MIN to MAX† | | | | UNIT |
|------------------|-----------------|----------------|-------------------------|---|------|--------------|-----|------|
| | | | | SN54ALS29821 | | SN74ALS29821 | | |
| | | | | MIN | MAX | MIN | MAX | |
| t _{PLH} | CLK | Any Q | C _L = 50 pF | 2 | 11.5 | 2 | 10 | ns |
| t _{PHL} | | | | 2 | 11.5 | 2 | 10 | |
| t _{PLH} | CLK | Any Q | C _L = 300 pF | 2 | 21 | 16 | | ns |
| t _{PHL} | | | | 2 | 21 | 16 | | |
| t _{PZH} | \overline{OE} | Any Q | C _L = 50 pF | 1 | 17 | 14 | | ns |
| t _{PZL} | | | | 1 | 17 | 14 | | |
| t _{PZH} | \overline{OE} | Any Q | C _L = 300 pF | 1 | 25 | 20 | | ns |
| t _{PZL} | | | | 1 | 29.5 | 23 | | |
| t _{PHZ} | \overline{OE} | Any Q | C _L = 50 pF | 1 | 16 | 14 | | ns |
| t _{PLZ} | | | | 1 | 14 | 12 | | |
| t _{PHZ} | \overline{OE} | Any Q | C _L = 5 pF | 1 | 12 | 9 | | ns |
| t _{PLZ} | | | | 1 | 11 | 9 | | |

† For conditions shown as MIN or MAX, use the appropriate value specified under recommended operating conditions.



PARAMETER MEASUREMENT INFORMATION

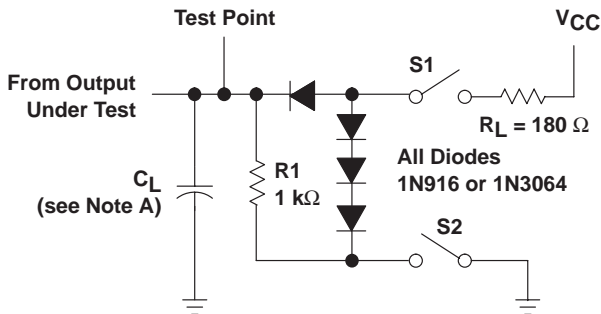

LOAD CIRCUIT

SWITCH POSITION TABLE

| TEST | S1 | S2 |
|------------------|--------|--------|
| t _{PLH} | Closed | Closed |
| t _{PHL} | Closed | Closed |
| t _{PZH} | Open | Closed |
| t _{PZL} | Closed | Open |
| t _{PHZ} | Closed | Closed |
| t _{PLZ} | Closed | Closed |

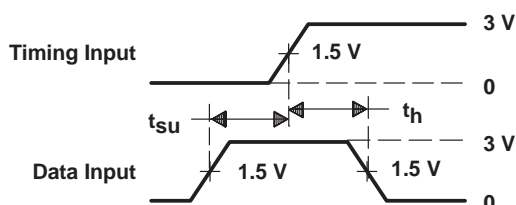

VOLTAGE WAVEFORMS
SETUP AND HOLD TIMES

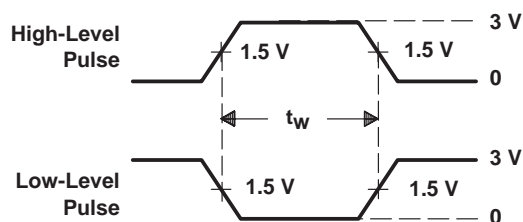

VOLTAGE WAVEFORMS
PULSE DURATIONS

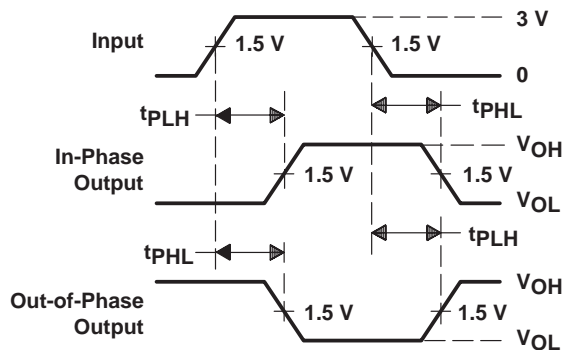

VOLTAGE WAVEFORMS
PROPAGATION DELAY TIMES

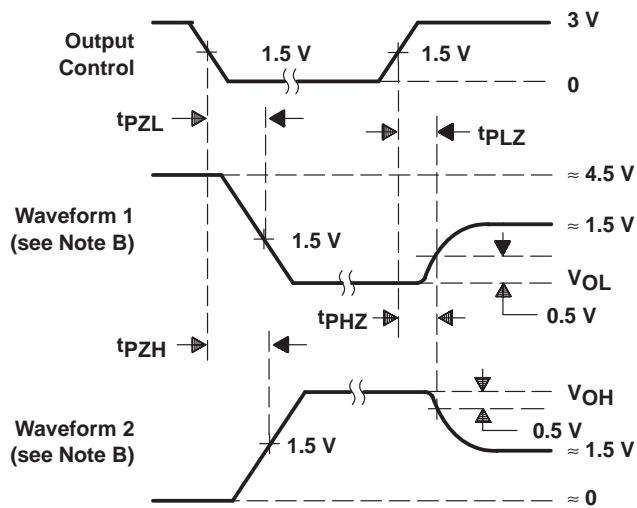

VOLTAGE WAVEFORMS
ENABLE AND DISABLE TIMES, 3-STATE OUTPUTS

- NOTES: A. C_L includes probe and jig capacitance.
 B. Waveform 1 is for an output with internal conditions such that the output is low except when disabled by the output control. Waveform 2 is for an output with internal conditions such that the output is high except when disabled by the output control.
 C. All input pulses are supplied by generators having the following characteristics: PRR \leq 10 MHz, $Z_O = 50 \Omega$, $t_r \leq 2.5$ ns, $t_f \leq 2.5$ ns.

Figure 1. Load Circuit and Voltage Waveforms

PACKAGING INFORMATION

| Orderable Device | Status ⁽¹⁾ | Package Type | Package Drawing | Pins | Package Qty | Eco Plan ⁽²⁾ | Lead/Ball Finish | MSL Peak Temp ⁽³⁾ |
|-------------------|-----------------------|--------------|-----------------|------|-------------|-------------------------|------------------|------------------------------|
| 5962-9061601LA | ACTIVE | CDIP | JT | 24 | 1 | TBD | A42 SNPB | N / A for Pkg Type |
| SN74ALS29821DW | ACTIVE | SOIC | DW | 24 | 25 | Green (RoHS & no Sb/Br) | CU NIPDAU | Level-1-260C-UNLIM |
| SN74ALS29821DWG4 | ACTIVE | SOIC | DW | 24 | 25 | Green (RoHS & no Sb/Br) | CU NIPDAU | Level-1-260C-UNLIM |
| SN74ALS29821DWR | ACTIVE | SOIC | DW | 24 | 2000 | Green (RoHS & no Sb/Br) | CU NIPDAU | Level-1-260C-UNLIM |
| SN74ALS29821DWRE4 | ACTIVE | SOIC | DW | 24 | 2000 | Green (RoHS & no Sb/Br) | CU NIPDAU | Level-1-260C-UNLIM |
| SN74ALS29821DWRG4 | ACTIVE | SOIC | DW | 24 | 2000 | Green (RoHS & no Sb/Br) | CU NIPDAU | Level-1-260C-UNLIM |
| SN74ALS29821NT | ACTIVE | PDIP | NT | 24 | 15 | Pb-Free (RoHS) | CU NIPDAU | N / A for Pkg Type |
| SN74ALS29821NTE4 | ACTIVE | PDIP | NT | 24 | 15 | Pb-Free (RoHS) | CU NIPDAU | N / A for Pkg Type |
| SNJ54ALS29821JT | ACTIVE | CDIP | JT | 24 | 1 | TBD | A42 SNPB | N / A for Pkg Type |

⁽¹⁾ The marketing status values are defined as follows:

ACTIVE: Product device recommended for new designs.

LIFEBUY: TI has announced that the device will be discontinued, and a lifetime-buy period is in effect.

NRND: Not recommended for new designs. Device is in production to support existing customers, but TI does not recommend using this part in a new design.

PREVIEW: Device has been announced but is not in production. Samples may or may not be available.

OBSOLETE: TI has discontinued the production of the device.

⁽²⁾ Eco Plan - The planned eco-friendly classification: Pb-Free (RoHS), Pb-Free (RoHS Exempt), or Green (RoHS & no Sb/Br) - please check <http://www.ti.com/productcontent> for the latest availability information and additional product content details.

TBD: The Pb-Free/Green conversion plan has not been defined.

Pb-Free (RoHS): TI's terms "Lead-Free" or "Pb-Free" mean semiconductor products that are compatible with the current RoHS requirements for all 6 substances, including the requirement that lead not exceed 0.1% by weight in homogeneous materials. Where designed to be soldered at high temperatures, TI Pb-Free products are suitable for use in specified lead-free processes.

Pb-Free (RoHS Exempt): This component has a RoHS exemption for either 1) lead-based flip-chip solder bumps used between the die and package, or 2) lead-based die adhesive used between the die and leadframe. The component is otherwise considered Pb-Free (RoHS compatible) as defined above.

Green (RoHS & no Sb/Br): TI defines "Green" to mean Pb-Free (RoHS compatible), and free of Bromine (Br) and Antimony (Sb) based flame retardants (Br or Sb do not exceed 0.1% by weight in homogeneous material)

⁽³⁾ MSL, Peak Temp. -- The Moisture Sensitivity Level rating according to the JEDEC industry standard classifications, and peak solder temperature.

Important Information and Disclaimer:The information provided on this page represents TI's knowledge and belief as of the date that it is provided. TI bases its knowledge and belief on information provided by third parties, and makes no representation or warranty as to the accuracy of such information. Efforts are underway to better integrate information from third parties. TI has taken and continues to take reasonable steps to provide representative and accurate information but may not have conducted destructive testing or chemical analysis on incoming materials and chemicals. TI and TI suppliers consider certain information to be proprietary, and thus CAS numbers and other limited information may not be available for release.

In no event shall TI's liability arising out of such information exceed the total purchase price of the TI part(s) at issue in this document sold by TI to Customer on an annual basis.

TAPE AND REEL INFORMATION



QUADRANT ASSIGNMENTS FOR PIN 1 ORIENTATION IN TAPE



*All dimensions are nominal

| Device | Package Type | Package Drawing | Pins | SPQ | Reel Diameter (mm) | Reel Width W1 (mm) | A0 (mm) | B0 (mm) | K0 (mm) | P1 (mm) | W (mm) | Pin1 Quadrant |
|-----------------|--------------|-----------------|------|------|--------------------|--------------------|---------|---------|---------|---------|--------|---------------|
| SN74ALS29821DWR | SOIC | DW | 24 | 2000 | 330.0 | 24.4 | 10.75 | 15.7 | 2.7 | 12.0 | 24.0 | Q1 |

TAPE AND REEL BOX DIMENSIONS

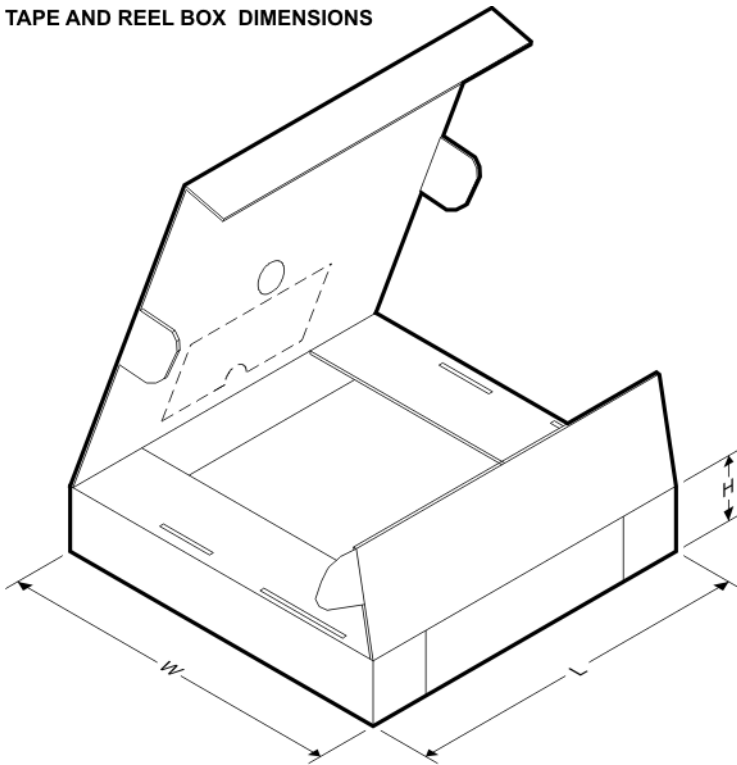

*All dimensions are nominal

| Device | Package Type | Package Drawing | Pins | SPQ | Length (mm) | Width (mm) | Height (mm) |
|-----------------|--------------|-----------------|------|------|-------------|------------|-------------|
| SN74ALS29821DWR | SOIC | DW | 24 | 2000 | 346.0 | 346.0 | 41.0 |

MECHANICAL DATA

NT (R-PDIP-T**) 24 PINS SHOWN

PLASTIC DUAL-IN-LINE PACKAGE

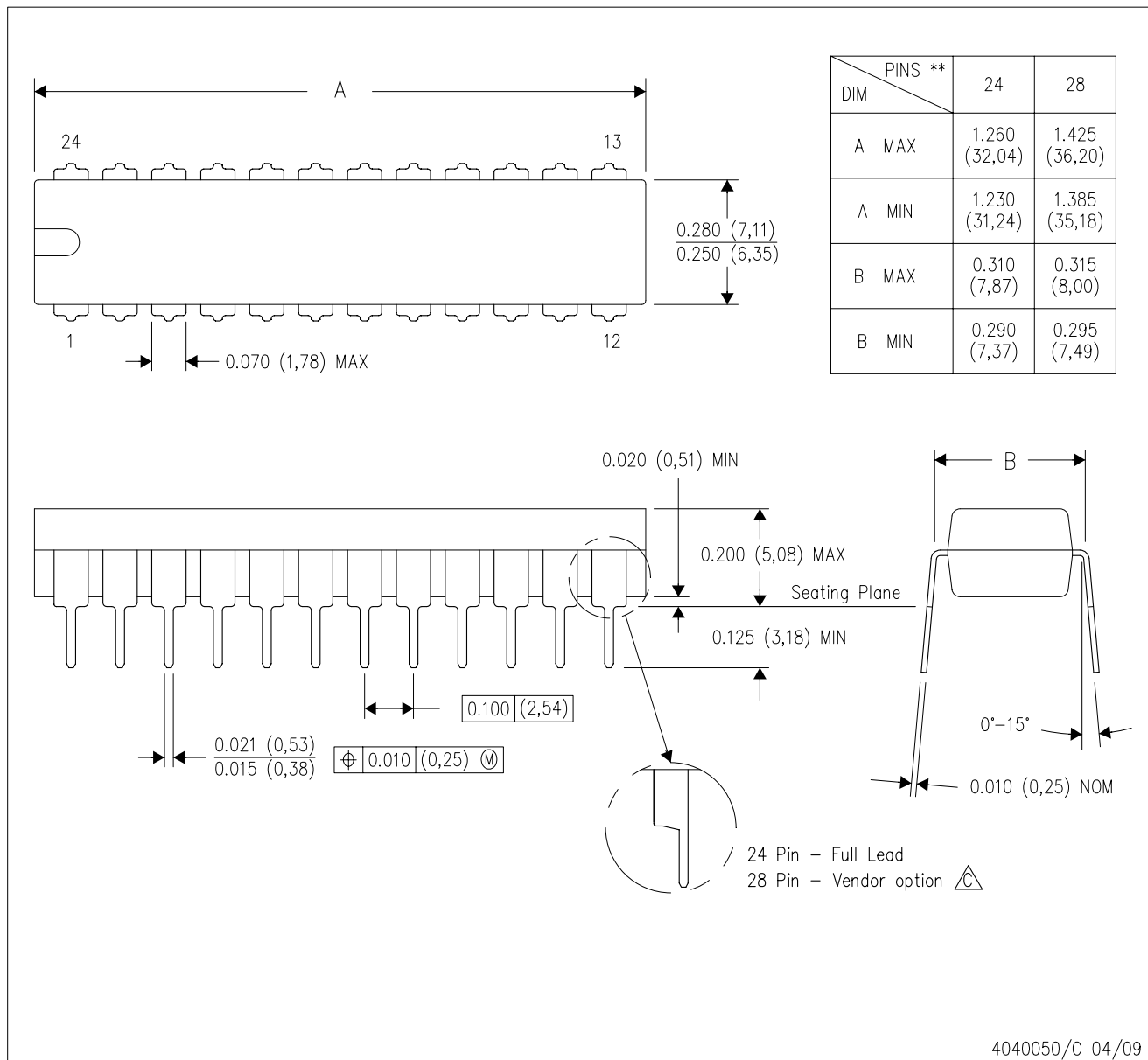

- NOTES:
- A. All linear dimensions are in millimeters. Dimensioning and tolerancing per ASME Y14.5M-1994.
 - B. This drawing is subject to change without notice.
 -  The 28 pin end lead shoulder width is a vendor option, either half or full width.

JT (R-GDIP-T**)

CERAMIC DUAL-IN-LINE

24 LEADS SHOWN

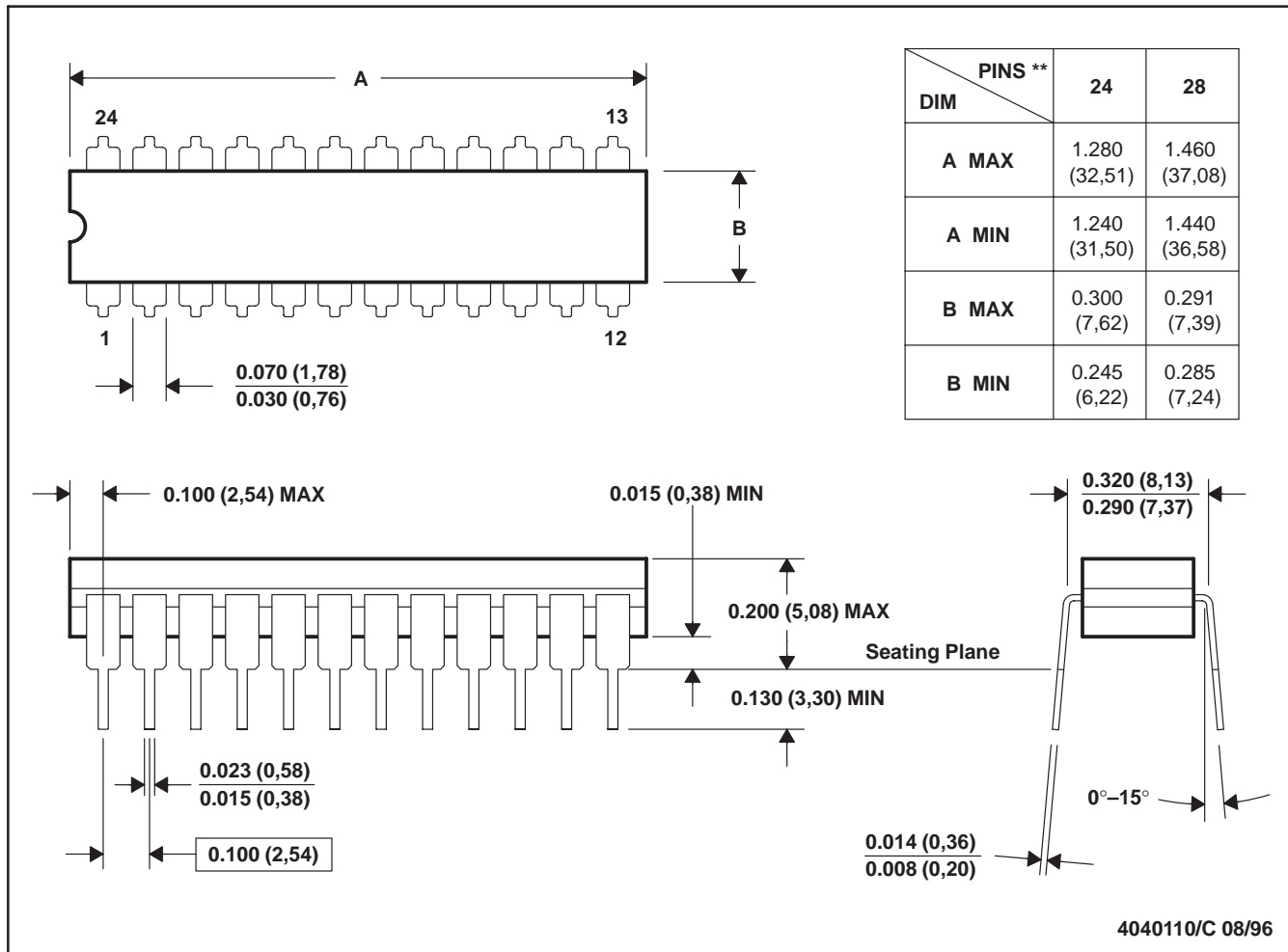

- NOTES: A. All linear dimensions are in inches (millimeters).
 B. This drawing is subject to change without notice.
 C. This package can be hermetically sealed with a ceramic lid using glass frit.
 D. Index point is provided on cap for terminal identification.
 E. Falls within MIL STD 1835 GDIP3-T24, GDIP4-T28, and JEDEC MO-058 AA, MO-058 AB

IMPORTANT NOTICE

Texas Instruments Incorporated and its subsidiaries (TI) reserve the right to make corrections, modifications, enhancements, improvements, and other changes to its products and services at any time and to discontinue any product or service without notice. Customers should obtain the latest relevant information before placing orders and should verify that such information is current and complete. All products are sold subject to TI's terms and conditions of sale supplied at the time of order acknowledgment.

TI warrants performance of its hardware products to the specifications applicable at the time of sale in accordance with TI's standard warranty. Testing and other quality control techniques are used to the extent TI deems necessary to support this warranty. Except where mandated by government requirements, testing of all parameters of each product is not necessarily performed.

TI assumes no liability for applications assistance or customer product design. Customers are responsible for their products and applications using TI components. To minimize the risks associated with customer products and applications, customers should provide adequate design and operating safeguards.

TI does not warrant or represent that any license, either express or implied, is granted under any TI patent right, copyright, mask work right, or other TI intellectual property right relating to any combination, machine, or process in which TI products or services are used. Information published by TI regarding third-party products or services does not constitute a license from TI to use such products or services or a warranty or endorsement thereof. Use of such information may require a license from a third party under the patents or other intellectual property of the third party, or a license from TI under the patents or other intellectual property of TI.

Reproduction of TI information in TI data books or data sheets is permissible only if reproduction is without alteration and is accompanied by all associated warranties, conditions, limitations, and notices. Reproduction of this information with alteration is an unfair and deceptive business practice. TI is not responsible or liable for such altered documentation. Information of third parties may be subject to additional restrictions.

Resale of TI products or services with statements different from or beyond the parameters stated by TI for that product or service voids all express and any implied warranties for the associated TI product or service and is an unfair and deceptive business practice. TI is not responsible or liable for any such statements.

TI products are not authorized for use in safety-critical applications (such as life support) where a failure of the TI product would reasonably be expected to cause severe personal injury or death, unless officers of the parties have executed an agreement specifically governing such use. Buyers represent that they have all necessary expertise in the safety and regulatory ramifications of their applications, and acknowledge and agree that they are solely responsible for all legal, regulatory and safety-related requirements concerning their products and any use of TI products in such safety-critical applications, notwithstanding any applications-related information or support that may be provided by TI. Further, Buyers must fully indemnify TI and its representatives against any damages arising out of the use of TI products in such safety-critical applications.

TI products are neither designed nor intended for use in military/aerospace applications or environments unless the TI products are specifically designated by TI as military-grade or "enhanced plastic." Only products designated by TI as military-grade meet military specifications. Buyers acknowledge and agree that any such use of TI products which TI has not designated as military-grade is solely at the Buyer's risk, and that they are solely responsible for compliance with all legal and regulatory requirements in connection with such use.

TI products are neither designed nor intended for use in automotive applications or environments unless the specific TI products are designated by TI as compliant with ISO/TS 16949 requirements. Buyers acknowledge and agree that, if they use any non-designated products in automotive applications, TI will not be responsible for any failure to meet such requirements.

Following are URLs where you can obtain information on other Texas Instruments products and application solutions:

Products

| | |
|-----------------------------|--|
| Amplifiers | amplifier.ti.com |
| Data Converters | dataconverter.ti.com |
| DLP® Products | www.dlp.com |
| DSP | dsp.ti.com |
| Clocks and Timers | www.ti.com/clocks |
| Interface | interface.ti.com |
| Logic | logic.ti.com |
| Power Mgmt | power.ti.com |
| Microcontrollers | microcontroller.ti.com |
| RFID | www.ti-rfid.com |
| RF/IF and ZigBee® Solutions | www.ti.com/lprf |

Applications

| | |
|--------------------|--|
| Audio | www.ti.com/audio |
| Automotive | www.ti.com/automotive |
| Broadband | www.ti.com/broadband |
| Digital Control | www.ti.com/digitalcontrol |
| Medical | www.ti.com/medical |
| Military | www.ti.com/military |
| Optical Networking | www.ti.com/opticalnetwork |
| Security | www.ti.com/security |
| Telephony | www.ti.com/telephony |
| Video & Imaging | www.ti.com/video |
| Wireless | www.ti.com/wireless |

Mailing Address: Texas Instruments, Post Office Box 655303, Dallas, Texas 75265
Copyright © 2009, Texas Instruments Incorporated