

SN54ALS257A, SN54ALS258A, SN74ALS257A, SN74ALS258A, SN74AS257, SN74AS258 QUADRUPLE 2-LINE TO 1-LINE DATA SELECTORS/MULTIPLEXERS WITH 3-STATE OUTPUTS

SDAS124C – APRIL 1982 – REVISED AUGUST 1996

- 3-State Outputs Interface Directly With System Bus
- Provide Bus Interface From Multiple Sources in High-Performance Systems
- Package Options Include Plastic Small-Outline (D) Packages, Ceramic Chip Carriers (FK), and Standard Plastic (N) and Ceramic (J) 300-mil DIPs

description

These data selectors/multiplexers are designed to multiplex signals from 4-bit data sources to 4-output data lines in bus-organized systems. The 3-state outputs do not load the data lines when the output-enable (\overline{OE}) input is at a high logic level.

The SN54ALS257A and SN54ALS258A are characterized for operation over the full military temperature range of -55°C to 125°C . The SN74ALS257A, SN74ALS258A, SN74AS257, and SN74AS258 are characterized for operation from 0°C to 70°C .

SN54ALS257A, SN54ALS258A . . . J PACKAGE
SN74ALS257A, SN74ALS258A, SN74AS257,
SN74AS258 . . . D OR N PACKAGE
(TOP VIEW)

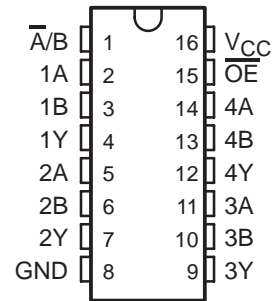

SN54ALS257A, SN54ALS258A . . . FK PACKAGE
(TOP VIEW)

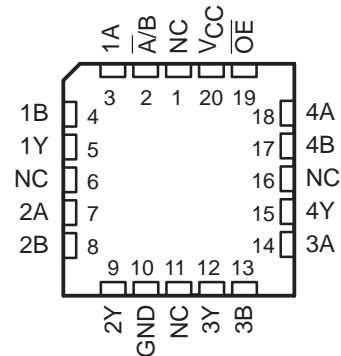

NC – No internal connection

FUNCTION TABLE

INPUTS			OUTPUT Y		
\overline{OE}	$\overline{A/B}$	DATA		SN54ALS257A SN74ALS257A SN74AS257	SN54ALS258A SN74ALS258A SN74AS258
		A	B		
H	X	X	X	Z	Z
L	L	L	X	L	H
L	L	H	X	H	L
L	H	X	L	L	H
L	H	X	H	H	L



Please be aware that an important notice concerning availability, standard warranty, and use in critical applications of Texas Instruments semiconductor products and disclaimers thereto appears at the end of this data sheet.

PRODUCTION DATA information is current as of publication date. Products conform to specifications per the terms of Texas Instruments standard warranty. Production processing does not necessarily include testing of all parameters.

 **TEXAS
INSTRUMENTS**

POST OFFICE BOX 655303 • DALLAS, TEXAS 75265
POST OFFICE BOX 1443 • HOUSTON, TEXAS 77251-1443

Copyright © 1996, Texas Instruments Incorporated

SN54ALS257A, SN54ALS258A, SN74ALS257A, SN74ALS258A, SN74AS257, SN74AS258 QUADRUPLE 2-LINE TO 1-LINE DATA SELECTORS/MULTIPLEXERS WITH 3-STATE OUTPUTS

SDAS124C – APRIL 1982 – REVISED AUGUST 1996

logic symbols†

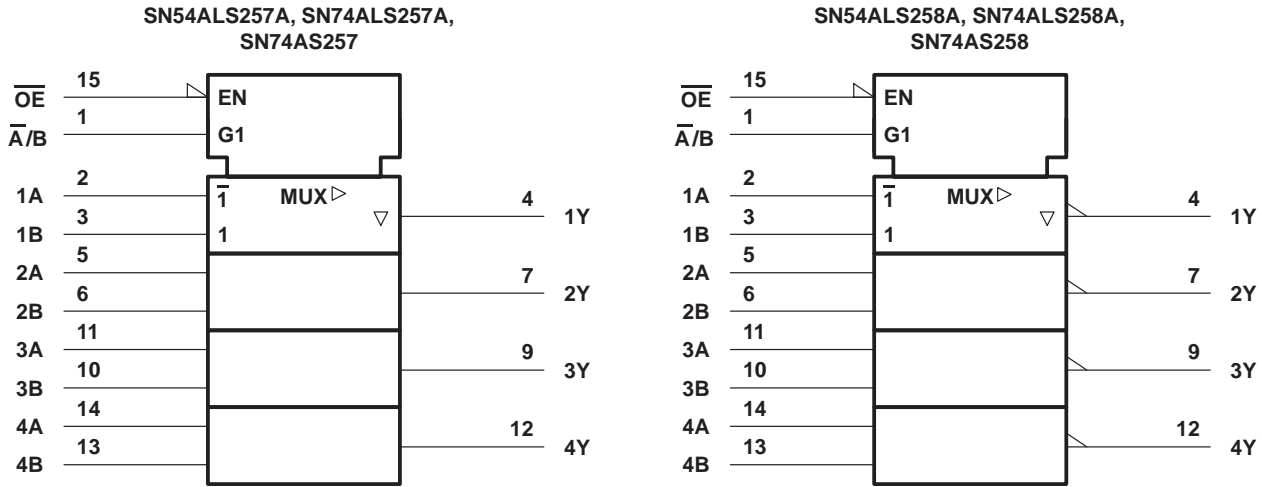

† These symbols are in accordance with ANSI/IEEE Std 91-1984 and IEC Publication 617-12. Pin numbers shown are for the D, J, and N packages.

logic diagrams (positive logic)

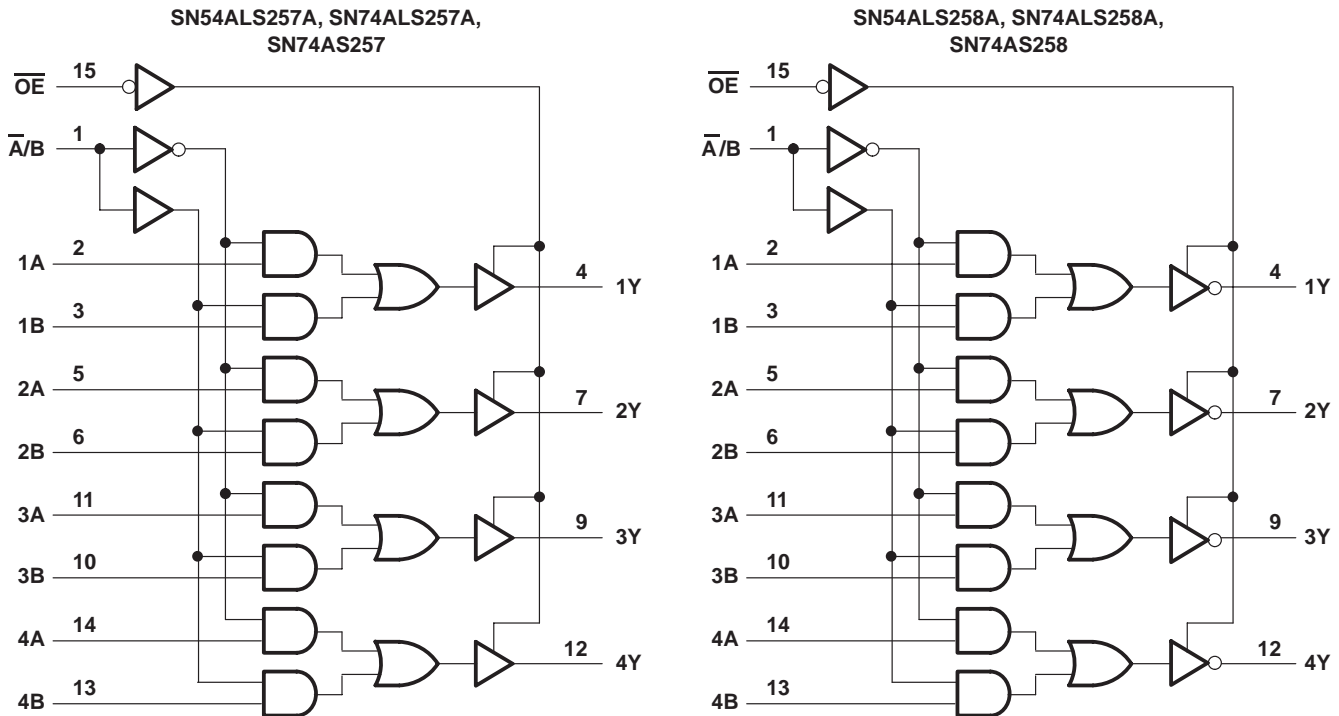

Pin numbers shown are for the D, J, and N packages.

SN54ALS257A, SN54ALS258A, SN74ALS257A, SN74ALS258A, SN74AS257, SN74AS258 QUADRUPLE 2-LINE TO 1-LINE DATA SELECTORS/MULTIPLEXERS WITH 3-STATE OUTPUTS

SDAS124C – APRIL 1982 – REVISED AUGUST 1996

absolute maximum ratings over operating free-air temperature range (unless otherwise noted)†

Supply voltage, V_{CC}	7 V
Input voltage, V_I	7 V
Voltage applied to a disabled 3-state output	5.5 V
Maximum power dissipation at $T_A = 55^\circ\text{C}$ (in still air) (see Note 1):	
D package	1.3 W
N package	1.1 W
Operating free-air temperature range, T_A : SN54ALS257A, SN54ALS258A	–55°C to 125°C
SN74ALS257A, SN74ALS258A	0°C to 70°C
Storage temperature range, T_{stg}	–65°C to 150°C

† Stresses beyond those listed under “absolute maximum ratings” may cause permanent damage to the device. These are stress ratings only, and functional operation of the device at these or any other conditions beyond those indicated under “recommended operating conditions” is not implied. Exposure to absolute-maximum-rated conditions for extended periods may affect device reliability.

NOTE 1: The maximum package power dissipation is calculated using a junction temperature of 150°C and a board trace length of 750 mils, except for the N package, which has a trace length of zero.

recommended operating conditions

	SN54ALS257A SN54ALS258A			SN74ALS257A SN74ALS258A			UNIT
	MIN	NOM	MAX	MIN	NOM	MAX	
V_{CC} Supply voltage	4.5	5	5.5	4.5	5	5.5	V
V_{IH} High-level input voltage	2			2			V
V_{IL} Low-level input voltage			0.7			0.8	V
I_{OH} High-level output current			–1			–2.6	mA
I_{OL} Low-level output current			12			24	mA
T_A Operating free-air temperature	–55		125	0		70	°C



SN54ALS257A, SN54ALS258A, SN74ALS257A, SN74ALS258A, SN74AS257, SN74AS258 QUADRUPLE 2-LINE TO 1-LINE DATA SELECTORS/MULTIPLEXERS WITH 3-STATE OUTPUTS

SDAS124C – APRIL 1982 – REVISED AUGUST 1996

electrical characteristics over recommended operating free-air temperature range (unless otherwise noted)

PARAMETER	TEST CONDITIONS		SN54ALS257A SN54ALS258A			SN74ALS257A SN74ALS258A			UNIT
			MIN	TYP†	MAX	MIN	TYP†	MAX	
V _{IK}	V _{CC} = 4.5 V, I _I = -18 mA		-1.5			-1.5			V
V _{OH}	V _{CC} = 4.5 V to 5.5 V, I _{OH} = -0.4 mA		V _{CC} -2			V _{CC} -2			V
	V _{CC} = 4.5 V	I _{OH} = -1 mA	2.4	3.3					
V _{OH}		V _{CC} = 4.5 V	I _{OH} = -2.6 mA			2.4	3.2		V
	I _{OL} = 12 mA		0.25	0.4	0.25	0.4			
V _{OH}	V _{CC} = 4.5 V	I _{OL} = 24 mA			0.35	0.5		V	
		I _{OZH}	V _{CC} = 5.5 V, V _O = 2.7 V		20		20		μA
I _{OZL}	V _{CC} = 5.5 V, V _O = 0.4 V		-20			-20			μA
I _I	V _{CC} = 5.5 V, V _I = 7 V		0.1			0.1			mA
I _{IH}	V _{CC} = 5.5 V, V _I = 2.7 V		20			20			μA
I _{IL}	V _{CC} = 5.5 V, V _I = 0.4 V		-0.1			-0.1			mA
I _{O‡}	V _{CC} = 5.5 V, V _O = 2.25 V		-20	-112	-30	-112	mA		
I _{CC}	SN54ALS257A, SN74ALS257A	V _{CC} = 5.5 V	Outputs high	3	8	3	6	mA	
			Outputs low	8	12	8	12		
			Outputs disabled	9	14	9	14		
	SN54ALS258A, SN74ALS258A	V _{CC} = 5.5 V	Outputs high	2.5	5	2.5	4		
			Outputs low	7	11	7	11		
			Outputs disabled	8	13	8	13		

† All typical values are at V_{CC} = 5 V, T_A = 25°C.

‡ The output conditions have been chosen to produce a current that closely approximates one half of the true short-circuit output current, I_{OS}.

switching characteristics (see Figure 1)

PARAMETER	FROM (INPUT)	TO (OUTPUT)	V _{CC} = 4.5 V to 5.5 V, C _L = 50 pF, R ₁ = 500 Ω, R ₂ = 500 Ω, T _A = MIN to MAX§				UNIT
			SN54ALS257A		SN74ALS257A		
			MIN	MAX	MIN	MAX	
t _{PLH}	A or B	Any Y	2	12	2	10	ns
t _{PHL}			2	14	2	12	
t _{PLH}	A̅/B	Any Y	4	21	6	18	ns
t _{PHL}			6	25	6	22	
t _{PZH}	OE̅	Any Y	3	20	4	16	ns
t _{PZL}			4	22	5	18	
t _{PHZ}	OE̅	Any Y	2	12	2	10	ns
t _{PLZ}			2	35	4	15	

§ For conditions shown MIN or MAX, use the appropriate value specified under recommended operating conditions.



SN54ALS257A, SN54ALS258A, SN74ALS257A, SN74ALS258A, SN74AS257, SN74AS258 QUADRUPLE 2-LINE TO 1-LINE DATA SELECTORS/MULTIPLEXERS WITH 3-STATE OUTPUTS

SDAS124C – APRIL 1982 – REVISED AUGUST 1996

switching characteristics (see Figure 1)

PARAMETER	FROM (INPUT)	TO (OUTPUT)	V _{CC} = 4.5 V to 5.5 V, C _L = 50 pF, R ₁ = 500 Ω, R ₂ = 500 Ω, T _A = MIN to MAX†				UNIT
			SN54ALS258A		SN74ALS258A		
			MIN	MAX	MIN	MAX	
t _{PLH}	A or B	Any Y	1	12	2	8	ns
t _{PHL}			2	9	2	7	
t _{PLH}	\bar{A}/B	Any Y	4	28	5	25	ns
t _{PHL}			5	25	6	20	
t _{PZH}	\overline{OE}	Any Y	3	20	4	18	ns
t _{PZL}			5	21	5	18	
t _{PHZ}	\overline{OE}	Any Y	2	12	2	10	ns
t _{PLZ}			3	37	4	18	

† For conditions shown MIN or MAX, use the appropriate value specified under recommended operating conditions.

absolute maximum ratings over operating free-air temperature range (unless otherwise noted)‡

Supply voltage, V _{CC}	7 V
Input voltage, V _I	7 V
Voltage applied to a disabled 3-state output	5.5 V
Maximum power dissipation at T _A = 55°C (in still air) (see Note 1):	
D package	1.3 W
N package	1.1 W
Operating free-air temperature range, T _A : SN74AS257, SN74AS258	0°C to 70°C
Storage temperature range, T _{stg}	-65°C to 150°C

‡ Stresses beyond those listed under “absolute maximum ratings” may cause permanent damage to the device. These are stress ratings only, and functional operation of the device at these or any other conditions beyond those indicated under “recommended operating conditions” is not implied. Exposure to absolute-maximum-rated conditions for extended periods may affect device reliability.

NOTE 1: The maximum package power dissipation is calculated using a junction temperature of 150°C and a board trace length of 750 mils, except for the N package, which has a trace length of zero.

recommended operating conditions

		SN74AS257 SN74AS258			UNIT
		MIN	NOM	MAX	
V _{CC}	Supply voltage	4.5	5	5.5	V
V _{IH}	High-level input voltage	2			V
V _{IL}	Low-level input voltage			0.8	V
I _{OH}	High-level output current			-15	mA
I _{OL}	Low-level output current			48	mA
T _A	Operating free-air temperature	0		70	°C



SN54ALS257A, SN54ALS258A, SN74ALS257A, SN74ALS258A, SN74AS257, SN74AS258 QUADRUPLE 2-LINE TO 1-LINE DATA SELECTORS/MULTIPLEXERS WITH 3-STATE OUTPUTS

SDAS124C – APRIL 1982 – REVISED AUGUST 1996

electrical characteristics over recommended operating free-air temperature range (unless otherwise noted)

PARAMETER	TEST CONDITIONS	SN74AS257 SN74AS258		UNIT		
		MIN	TYP†		MAX	
V_{IK}	$V_{CC} = 4.5\text{ V}$, $I_I = -18\text{ mA}$	-1.2		V		
V_{OH}	$V_{CC} = 4.5\text{ V to } 5.5\text{ V}$, $I_{OH} = -2\text{ mA}$	$V_{CC}-2$		V		
	$V_{CC} = 4.5\text{ V}$, $I_{OH} = -15\text{ mA}$	2.4	3.2			
V_{OL}	$V_{CC} = 4.5\text{ V}$, $I_{OL} = 48\text{ mA}$	0.35	0.5	V		
I_{OZH}	$V_{CC} = 5.5\text{ V}$, $V_O = 2.7\text{ V}$	50		μA		
I_{OZL}	$V_{CC} = 5.5\text{ V}$, $V_O = 0.4\text{ V}$	-50		μA		
I_I	A, B, or \overline{OE}	$V_{CC} = 5.5\text{ V}$, $V_I = 7\text{ V}$		mA		
	$\overline{A/B}$				0.1	0.2
I_{IH}	A, B, or \overline{OE}	$V_{CC} = 5.5\text{ V}$, $V_I = 2.7\text{ V}$		μA		
	$\overline{A/B}$				20	40
I_{IL}	A, B, or \overline{OE}	$V_{CC} = 5.5\text{ V}$, $V_I = 0.4\text{ V}$		mA		
	$\overline{A/B}$				-0.5	-1
$I_{O\ddagger}$	$V_{CC} = 5.5\text{ V}$, $V_O = 2.25\text{ V}$	-30	-112	mA		
I_{CC}	SN74AS257	$V_{CC} = 5.5\text{ V}$	Outputs high	12.1	19.7	mA
			Outputs low	19	30.6	
			Outputs disabled	19.7	31.9	
	SN74AS258	$V_{CC} = 5.5\text{ V}$	Outputs high	8.4	13.5	
			Outputs low	15.2	24.6	
			Outputs disabled	15.5	25.2	

† All typical values are at $V_{CC} = 5\text{ V}$, $T_A = 25^\circ\text{C}$.

‡ The output conditions have been chosen to produce a current that closely approximates one half of the true short-circuit output current, I_{OS} .



SN54ALS257A, SN54ALS258A, SN74ALS257A, SN74ALS258A, SN74AS257, SN74AS258 QUADRUPLE 2-LINE TO 1-LINE DATA SELECTORS/MULTIPLEXERS WITH 3-STATE OUTPUTS

SDAS124C – APRIL 1982 – REVISED AUGUST 1996

switching characteristics (see Figure 1)

PARAMETER	FROM (INPUT)	TO (OUTPUT)	V _{CC} = 4.5 V to 5.5 V, C _L = 50 pF, R ₁ = 500 Ω, R ₂ = 500 Ω, T _A = MIN to MAX†		UNIT
			SN74AS257		
			MIN	MAX	
t _{PLH}	A or B	Any Y	1	5.5	ns
t _{PHL}			1	6	
t _{PLH}	\bar{A}/B	Any Y	2	11	ns
t _{PHL}			2	10	
t _{PZH}	\overline{OE}	Any Y	2	7.5	ns
t _{PZL}			2	9.5	
t _{PHZ}	\overline{OE}	Any Y	1.5	6.5	ns
t _{PLZ}			2	7	

switching characteristics (see Figure 1)

PARAMETER	FROM (INPUT)	TO (OUTPUT)	V _{CC} = 4.5 V to 5.5 V, C _L = 50 pF, R ₁ = 500 Ω, R ₂ = 500 Ω, T _A = MIN to MAX†		UNIT
			SN74AS258		
			MIN	MAX	
t _{PLH}	A or B	Any Y	1	5	ns
t _{PHL}			1	4	
t _{PLH}	\bar{A}/B	Any Y	2	9.5	ns
t _{PHL}			2	10	
t _{PZH}	\overline{OE}	Any Y	2	8	ns
t _{PZL}			2	10	
t _{PHZ}	\overline{OE}	Any Y	1.5	6	ns
t _{PLZ}			2	6.5	

† For conditions shown MIN or MAX, use the appropriate value specified under recommended operating conditions.



SN54ALS257A, SN54ALS258A, SN74ALS257A, SN74ALS258A, SN74AS257, SN74AS258 QUADRUPLE 2-LINE TO 1-LINE DATA SELECTORS/MULTIPLEXERS WITH 3-STATE OUTPUTS

SDAS124C – APRIL 1982 – REVISED AUGUST 1996

PARAMETER MEASUREMENT INFORMATION SERIES 54ALS/74ALS AND 54AS/74AS DEVICES

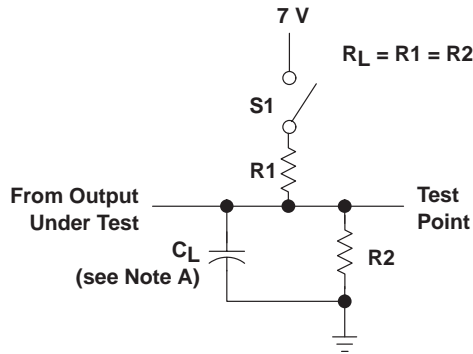

LOAD CIRCUIT
FOR 3-STATE OUTPUTS

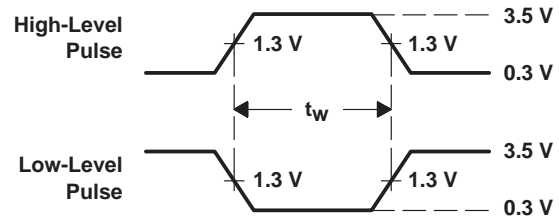

VOLTAGE WAVEFORMS
PULSE DURATIONS

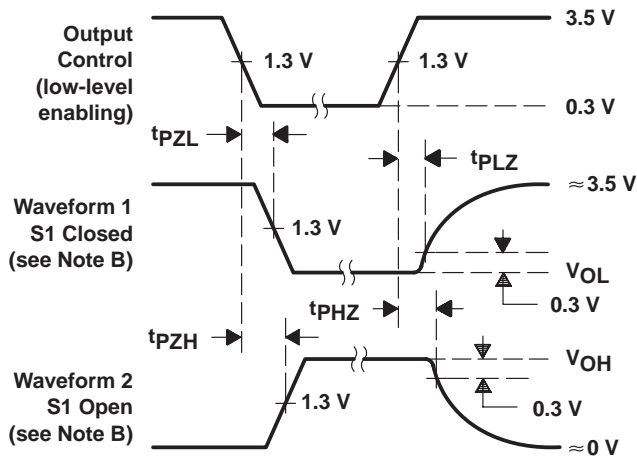

VOLTAGE WAVEFORMS
ENABLE AND DISABLE TIMES, 3-STATE OUTPUTS

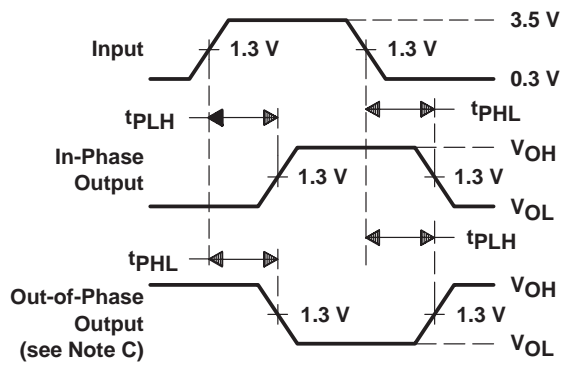

VOLTAGE WAVEFORMS
PROPAGATION DELAY TIMES

- NOTES: A. C_L includes probe and jig capacitance.
 B. Waveform 1 is for an output with internal conditions such that the output is low except when disabled by the output control. Waveform 2 is for an output with internal conditions such that the output is high except when disabled by the output control.
 C. When measuring propagation delay items of 3-state outputs, switch S1 is open.
 D. All input pulses have the following characteristics: $PRR \leq 1$ MHz, $t_r = t_f = 2$ ns, duty cycle = 50%.
 E. The outputs are measured one at a time with one transition per measurement.

Figure 1. Load Circuits and Voltage Waveforms



PACKAGING INFORMATION

Orderable Device	Status (1)	Package Type	Package Drawing	Pins	Package Qty	Eco Plan (2)	Lead finish/ Ball material (6)	MSL Peak Temp (3)	Op Temp (°C)	Device Marking (4/5)	Samples
5962-8862601EA	ACTIVE	CDIP	J	16	1	Non-RoHS & Green	SNPB	N / A for Pkg Type	-55 to 125	5962-8862601EA SNJ54ALS258AJ	Samples
85097012A	ACTIVE	LCCC	FK	20	1	Non-RoHS & Green	SNPB	N / A for Pkg Type	-55 to 125	85097012A SNJ54ALS 257AFK	Samples
8509701EA	ACTIVE	CDIP	J	16	1	Non-RoHS & Green	SNPB	N / A for Pkg Type	-55 to 125	8509701EA SNJ54ALS257AJ	Samples
SN74ALS257AD	ACTIVE	SOIC	D	16	40	RoHS & Green	NIPDAU	Level-1-260C-UNLIM	0 to 70	ALS257A	Samples
SN74ALS257ADG4	ACTIVE	SOIC	D	16	40	RoHS & Green	NIPDAU	Level-1-260C-UNLIM	0 to 70	ALS257A	Samples
SN74ALS257ADR	ACTIVE	SOIC	D	16	2500	RoHS & Green	NIPDAU	Level-1-260C-UNLIM	0 to 70	ALS257A	Samples
SN74ALS257AN	ACTIVE	PDIP	N	16	25	RoHS & Green	NIPDAU	N / A for Pkg Type	0 to 70	SN74ALS257AN	Samples
SN74ALS257ANE4	ACTIVE	PDIP	N	16	25	RoHS & Green	NIPDAU	N / A for Pkg Type	0 to 70	SN74ALS257AN	Samples
SN74ALS257ANSR	ACTIVE	SO	NS	16	2000	RoHS & Green	NIPDAU	Level-1-260C-UNLIM	0 to 70	ALS257A	Samples
SN74ALS258AN	ACTIVE	PDIP	N	16	25	RoHS & Green	NIPDAU	N / A for Pkg Type	0 to 70	SN74ALS258AN	Samples
SN74ALS258ANE4	ACTIVE	PDIP	N	16	25	RoHS & Green	NIPDAU	N / A for Pkg Type	0 to 70	SN74ALS258AN	Samples
SN74AS257D	ACTIVE	SOIC	D	16	40	RoHS & Green	NIPDAU	Level-1-260C-UNLIM	0 to 70	AS257	Samples
SN74AS257N	ACTIVE	PDIP	N	16	25	RoHS & Green	NIPDAU	N / A for Pkg Type	0 to 70	SN74AS257N	Samples
SN74AS257NSR	ACTIVE	SO	NS	16	2000	RoHS & Green	NIPDAU	Level-1-260C-UNLIM	0 to 70	74AS257	Samples
SN74AS258N	ACTIVE	PDIP	N	16	25	RoHS & Green	NIPDAU	N / A for Pkg Type	0 to 70	SN74AS258N	Samples
SNJ54ALS257AFK	ACTIVE	LCCC	FK	20	1	Non-RoHS & Green	SNPB	N / A for Pkg Type	-55 to 125	85097012A SNJ54ALS 257AFK	Samples
SNJ54ALS257AJ	ACTIVE	CDIP	J	16	1	Non-RoHS & Green	SNPB	N / A for Pkg Type	-55 to 125	8509701EA SNJ54ALS257AJ	Samples
SNJ54ALS258AJ	ACTIVE	CDIP	J	16	1	Non-RoHS & Green	SNPB	N / A for Pkg Type	-55 to 125	5962-8862601EA SNJ54ALS258AJ	Samples

(1) The marketing status values are defined as follows:

ACTIVE: Product device recommended for new designs.

LIFEBUY: TI has announced that the device will be discontinued, and a lifetime-buy period is in effect.

NRND: Not recommended for new designs. Device is in production to support existing customers, but TI does not recommend using this part in a new design.

PREVIEW: Device has been announced but is not in production. Samples may or may not be available.

OBSOLETE: TI has discontinued the production of the device.

(2) **RoHS:** TI defines "RoHS" to mean semiconductor products that are compliant with the current EU RoHS requirements for all 10 RoHS substances, including the requirement that RoHS substance do not exceed 0.1% by weight in homogeneous materials. Where designed to be soldered at high temperatures, "RoHS" products are suitable for use in specified lead-free processes. TI may reference these types of products as "Pb-Free".

RoHS Exempt: TI defines "RoHS Exempt" to mean products that contain lead but are compliant with EU RoHS pursuant to a specific EU RoHS exemption.

Green: TI defines "Green" to mean the content of Chlorine (Cl) and Bromine (Br) based flame retardants meet JS709B low halogen requirements of ≤ 1000 ppm threshold. Antimony trioxide based flame retardants must also meet the ≤ 1000 ppm threshold requirement.

(3) MSL, Peak Temp. - The Moisture Sensitivity Level rating according to the JEDEC industry standard classifications, and peak solder temperature.

(4) There may be additional marking, which relates to the logo, the lot trace code information, or the environmental category on the device.

(5) Multiple Device Markings will be inside parentheses. Only one Device Marking contained in parentheses and separated by a "~" will appear on a device. If a line is indented then it is a continuation of the previous line and the two combined represent the entire Device Marking for that device.

(6) Lead finish/Ball material - Orderable Devices may have multiple material finish options. Finish options are separated by a vertical ruled line. Lead finish/Ball material values may wrap to two lines if the finish value exceeds the maximum column width.

Important Information and Disclaimer:The information provided on this page represents TI's knowledge and belief as of the date that it is provided. TI bases its knowledge and belief on information provided by third parties, and makes no representation or warranty as to the accuracy of such information. Efforts are underway to better integrate information from third parties. TI has taken and continues to take reasonable steps to provide representative and accurate information but may not have conducted destructive testing or chemical analysis on incoming materials and chemicals. TI and TI suppliers consider certain information to be proprietary, and thus CAS numbers and other limited information may not be available for release.

In no event shall TI's liability arising out of such information exceed the total purchase price of the TI part(s) at issue in this document sold by TI to Customer on an annual basis.

OTHER QUALIFIED VERSIONS OF SN54ALS257A, SN54ALS258A, SN74ALS257A, SN74ALS258A :

● Catalog : [SN74ALS257A](#), [SN74ALS258A](#)

● Military : [SN54ALS257A](#), [SN54ALS258A](#)

NOTE: Qualified Version Definitions:

- Catalog - TI's standard catalog product
- Military - QML certified for Military and Defense Applications

TAPE AND REEL INFORMATION

QUADRANT ASSIGNMENTS FOR PIN 1 ORIENTATION IN TAPE

*All dimensions are nominal

Device	Package Type	Package Drawing	Pins	SPQ	Reel Diameter (mm)	Reel Width W1 (mm)	A0 (mm)	B0 (mm)	K0 (mm)	P1 (mm)	W (mm)	Pin1 Quadrant
SN74ALS257ADR	SOIC	D	16	2500	330.0	16.4	6.5	10.3	2.1	8.0	16.0	Q1
SN74ALS257ANSR	SO	NS	16	2000	330.0	16.4	8.2	10.5	2.5	12.0	16.0	Q1
SN74AS257NSR	SO	NS	16	2000	330.0	16.4	8.2	10.5	2.5	12.0	16.0	Q1

TAPE AND REEL BOX DIMENSIONS

*All dimensions are nominal

Device	Package Type	Package Drawing	Pins	SPQ	Length (mm)	Width (mm)	Height (mm)
SN74ALS257ADR	SOIC	D	16	2500	340.5	336.1	32.0
SN74ALS257ANSR	SO	NS	16	2000	356.0	356.0	35.0
SN74AS257NSR	SO	NS	16	2000	356.0	356.0	35.0

TUBE

*All dimensions are nominal

Device	Package Name	Package Type	Pins	SPQ	L (mm)	W (mm)	T (µm)	B (mm)
85097012A	FK	LCCC	20	1	506.98	12.06	2030	NA
SN74ALS257AD	D	SOIC	16	40	507	8	3940	4.32
SN74ALS257ADG4	D	SOIC	16	40	507	8	3940	4.32
SN74ALS257AN	N	PDIP	16	25	506	13.97	11230	4.32
SN74ALS257AN	N	PDIP	16	25	506	13.97	11230	4.32
SN74ALS257ANE4	N	PDIP	16	25	506	13.97	11230	4.32
SN74ALS257ANE4	N	PDIP	16	25	506	13.97	11230	4.32
SN74ALS258AN	N	PDIP	16	25	506	13.97	11230	4.32
SN74ALS258AN	N	PDIP	16	25	506	13.97	11230	4.32
SN74ALS258ANE4	N	PDIP	16	25	506	13.97	11230	4.32
SN74ALS258ANE4	N	PDIP	16	25	506	13.97	11230	4.32
SN74AS257D	D	SOIC	16	40	507	8	3940	4.32
SN74AS257N	N	PDIP	16	25	506	13.97	11230	4.32
SN74AS257N	N	PDIP	16	25	506	13.97	11230	4.32
SN74AS258N	N	PDIP	16	25	506	13.97	11230	4.32
SN74AS258N	N	PDIP	16	25	506	13.97	11230	4.32
SNJ54ALS257AFK	FK	LCCC	20	1	506.98	12.06	2030	NA

J (R-GDIP-T**)

14 LEADS SHOWN

CERAMIC DUAL IN-LINE PACKAGE



DIM \ PINS **	14	16	18	20
A	0.300 (7,62) BSC	0.300 (7,62) BSC	0.300 (7,62) BSC	0.300 (7,62) BSC
B MAX	0.785 (19,94)	.840 (21,34)	0.960 (24,38)	1.060 (26,92)
B MIN	—	—	—	—
C MAX	0.300 (7,62)	0.300 (7,62)	0.310 (7,87)	0.300 (7,62)
C MIN	0.245 (6,22)	0.245 (6,22)	0.220 (5,59)	0.245 (6,22)



4040083/F 03/03

- NOTES:
- All linear dimensions are in inches (millimeters).
 - This drawing is subject to change without notice.
 - This package is hermetically sealed with a ceramic lid using glass frit.
 - Index point is provided on cap for terminal identification only on press ceramic glass frit seal only.
 - Falls within MIL STD 1835 GDIP1-T14, GDIP1-T16, GDIP1-T18 and GDIP1-T20.

N (R-PDIP-T**)

PLASTIC DUAL-IN-LINE PACKAGE

16 PINS SHOWN



- NOTES:
- A. All linear dimensions are in inches (millimeters).
 - B. This drawing is subject to change without notice.
 - Falls within JEDEC MS-001, except 18 and 20 pin minimum body length (Dim A).
 - The 20 pin end lead shoulder width is a vendor option, either half or full width.



PACKAGE OUTLINE

NS0016A

SOP - 2.00 mm max height

SOP



4220735/A 12/2021

NOTES:

1. All linear dimensions are in millimeters. Dimensions in parenthesis are for reference only. Dimensioning and tolerancing per ASME Y14.5M.
2. This drawing is subject to change without notice.
3. This dimension does not include mold flash, protrusions, or gate burrs. Mold flash, protrusions, or gate burrs shall not exceed 0.15 mm, per side.
4. This dimension does not include interlead flash. Interlead flash shall not exceed 0.25 mm, per side.

EXAMPLE BOARD LAYOUT

NS0016A

SOP - 2.00 mm max height

SOP



SOLDER MASK DETAILS

4220735/A 12/2021

NOTES: (continued)

5. Publication IPC-7351 may have alternate designs.

6. Solder mask tolerances between and around signal pads can vary based on board fabrication site.

EXAMPLE STENCIL DESIGN

NS0016A

SOP - 2.00 mm max height

SOP



SOLDER PASTE EXAMPLE
BASED ON 0.125 mm THICK STENCIL
SCALE:7X

4220735/A 12/2021

NOTES: (continued)

7. Laser cutting apertures with trapezoidal walls and rounded corners may offer better paste release. IPC-7525 may have alternate design recommendations.
8. Board assembly site may have different recommendations for stencil design.

FK (S-CQCC-N**)

LEADLESS CERAMIC CHIP CARRIER

28 TERMINAL SHOWN



NO. OF TERMINALS **	A		B	
	MIN	MAX	MIN	MAX
20	0.342 (8,69)	0.358 (9,09)	0.307 (7,80)	0.358 (9,09)
28	0.442 (11,23)	0.458 (11,63)	0.406 (10,31)	0.458 (11,63)
44	0.640 (16,26)	0.660 (16,76)	0.495 (12,58)	0.560 (14,22)
52	0.740 (18,78)	0.761 (19,32)	0.495 (12,58)	0.560 (14,22)
68	0.938 (23,83)	0.962 (24,43)	0.850 (21,6)	0.858 (21,8)
84	1.141 (28,99)	1.165 (29,59)	1.047 (26,6)	1.063 (27,0)



4040140/D 01/11

- NOTES:
- All linear dimensions are in inches (millimeters).
 - This drawing is subject to change without notice.
 - This package can be hermetically sealed with a metal lid.
 - Falls within JEDEC MS-004

D (R-PDSO-G16)

PLASTIC SMALL OUTLINE



- NOTES:
- A. All linear dimensions are in inches (millimeters).
 - B. This drawing is subject to change without notice.
 - C. Body length does not include mold flash, protrusions, or gate burrs. Mold flash, protrusions, or gate burrs shall not exceed 0.006 (0,15) each side.
 - D. Body width does not include interlead flash. Interlead flash shall not exceed 0.017 (0,43) each side.
 - E. Reference JEDEC MS-012 variation AC.

D (R-PDSO-G16)

PLASTIC SMALL OUTLINE



- NOTES:
- All linear dimensions are in millimeters.
 - This drawing is subject to change without notice.
 - Publication IPC-7351 is recommended for alternate designs.
 - Laser cutting apertures with trapezoidal walls and also rounding corners will offer better paste release. Customers should contact their board assembly site for stencil design recommendations. Refer to IPC-7525 for other stencil recommendations.
 - Customers should contact their board fabrication site for solder mask tolerances between and around signal pads.

MECHANICAL DATA

NS (R-PDSO-G**)

PLASTIC SMALL-OUTLINE PACKAGE

14-PINS SHOWN



- NOTES:
- A. All linear dimensions are in millimeters.
 - B. This drawing is subject to change without notice.
 - C. Body dimensions do not include mold flash or protrusion, not to exceed 0,15.

IMPORTANT NOTICE AND DISCLAIMER

TI PROVIDES TECHNICAL AND RELIABILITY DATA (INCLUDING DATA SHEETS), DESIGN RESOURCES (INCLUDING REFERENCE DESIGNS), APPLICATION OR OTHER DESIGN ADVICE, WEB TOOLS, SAFETY INFORMATION, AND OTHER RESOURCES "AS IS" AND WITH ALL FAULTS, AND DISCLAIMS ALL WARRANTIES, EXPRESS AND IMPLIED, INCLUDING WITHOUT LIMITATION ANY IMPLIED WARRANTIES OF MERCHANTABILITY, FITNESS FOR A PARTICULAR PURPOSE OR NON-INFRINGEMENT OF THIRD PARTY INTELLECTUAL PROPERTY RIGHTS.

These resources are intended for skilled developers designing with TI products. You are solely responsible for (1) selecting the appropriate TI products for your application, (2) designing, validating and testing your application, and (3) ensuring your application meets applicable standards, and any other safety, security, regulatory or other requirements.

These resources are subject to change without notice. TI grants you permission to use these resources only for development of an application that uses the TI products described in the resource. Other reproduction and display of these resources is prohibited. No license is granted to any other TI intellectual property right or to any third party intellectual property right. TI disclaims responsibility for, and you will fully indemnify TI and its representatives against, any claims, damages, costs, losses, and liabilities arising out of your use of these resources.

TI's products are provided subject to [TI's Terms of Sale](#) or other applicable terms available either on ti.com or provided in conjunction with such TI products. TI's provision of these resources does not expand or otherwise alter TI's applicable warranties or warranty disclaimers for TI products.

TI objects to and rejects any additional or different terms you may have proposed.

Mailing Address: Texas Instruments, Post Office Box 655303, Dallas, Texas 75265
Copyright © 2022, Texas Instruments Incorporated