

# SN54ALS160B THRU SN54ALS163B, SN54AS160 THRU SN54AS163 SN74ALS160B THRU SN74ALS163B, SN74AS160 THRU SN74AS163 SYNCHRONOUS 4-BIT DECADE AND BINARY COUNTERS

SDAS024A - D2661, APRIL 1982 - REVISED MAY 1986

- Internal Look-Ahead for Fast Counting
- Carry Output for n-Bit Cascading
- Synchronous Counting
- Synchronously Programmable
- Package Options include Plastic Small Outline Packages, Ceramic Chip Carriers, and Standard Plastic and Ceramic 300-mil DIPs
- Dependable Texas Instruments Quality and Reliability

## description

These synchronous, presettable counters feature an internal carry look-ahead for application in high-speed counting designs. The 'ALS160B, 'ALS162B, 'AS160, and 'AS162 are decade counters, and the 'ALS161B, 'ALS163B, 'AS161, and 'AS163 are 4-bit binary counters. Synchronous operation is provided by having all flip-flops clocked simultaneously so that the outputs change coincident with each other when so instructed by the count-enable inputs and internal gating. This mode of operation eliminates the output counting spikes that are normally associated with asynchronous (ripple clock) counters. A buffered clock input triggers the four flip-flops on the rising (positive-going) edge of the clock input waveform.

These counters are fully programmable; that is, they may be preset to any number between 0 and 9, or 15. As presetting is synchronous, setting up a low level at the load input disables the counter and causes the outputs to agree with the setup data after the next clock pulse regardless of the levels of the enable inputs.

The clear function for the 'ALS160B, 'ALS161B, 'AS160, and 'AS161 is asynchronous and a low level at the clear input sets all four of the flip-flop outputs low regardless of the levels of the clock, load, or enable inputs. This synchronous clear allows the count length to be modified easily by decoding the Q outputs for the maximum count desired. The active-low output of the gate used for decoding is connected to the clear input to synchronously clear the counter to 0000 (LLLL).

The carry look-ahead circuitry provides for cascading counters for n-bit synchronous applications without additional gating. Instrumental in accomplishing this function are two count-enable inputs and a ripple carry output. Both count-enable inputs (ENP and ENT) must be high to count, and ENT is fed forward to enable the ripple carry output. The ripple carry output (RCO) thus enabled will produce a high-level pulse while the count is maximum (9 or 15 with  $Q_A$  high). This high-level overflow ripple carry pulse can be used to enable successive cascaded stages. Transitions at the ENP or ENT are allowed regardless of the level of the clock input.

These counters feature a fully independent clock circuit. Changes at control inputs (ENP, ENT, or  $\overline{LOAD}$ ) that will modify the operating mode have no effect on the contents of the counter until clocking occurs. The function of the counter (whether enabled, disabled, loading, or counting) will be dictated solely by the conditions meeting the stable setup and hold times.

The SN54ALS160B through SN54ALS163B and SN54AS160 through SN54AS163 are characterized for operation over the full military temperature range of  $-55^{\circ}\text{C}$  to  $125^{\circ}\text{C}$ . The SN74ALS160B through SN74ALS163B and SN74AS160 through SN74AS163 are characterized for operation from  $0^{\circ}\text{C}$  to  $70^{\circ}\text{C}$ .

SN54ALS', SN54AS' ... J PACKAGE  
SN74ALS', SN74AS' ... D OR N PACKAGE  
(TOP VIEW)

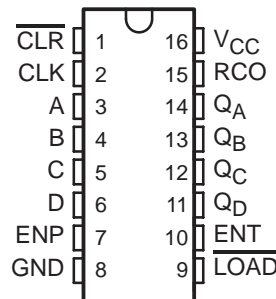

SN54ALS', SN54AS' ... FK PACKAGE  
(TOP VIEW)

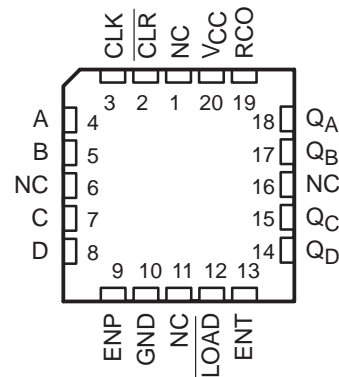

NC—No internal connection

**SN54ALS160B, SN54ALS162B, SN54AS160, SN54AS162  
SN74ALS160B, SN74ALS162B, SN74AS160, SN74AS162  
SYNCHRONOUS 4-BIT BINARY COUNTERS**

SDAS024A – D2661, APRIL 1982 – REVISED MAY 1986

**logic symbols†**

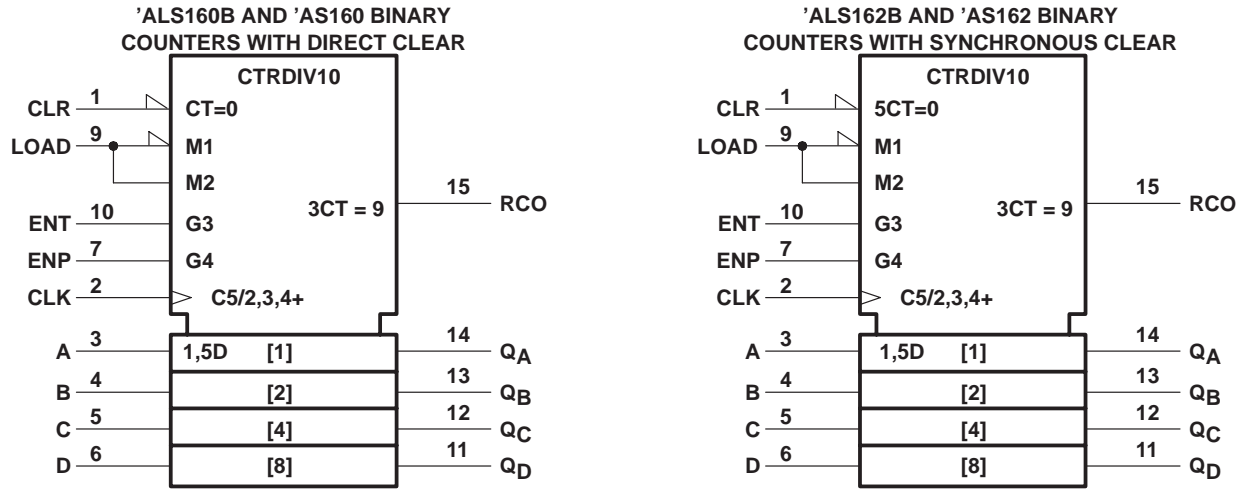

**'ALS160B and 'AS160 logic diagram (positive logic)**

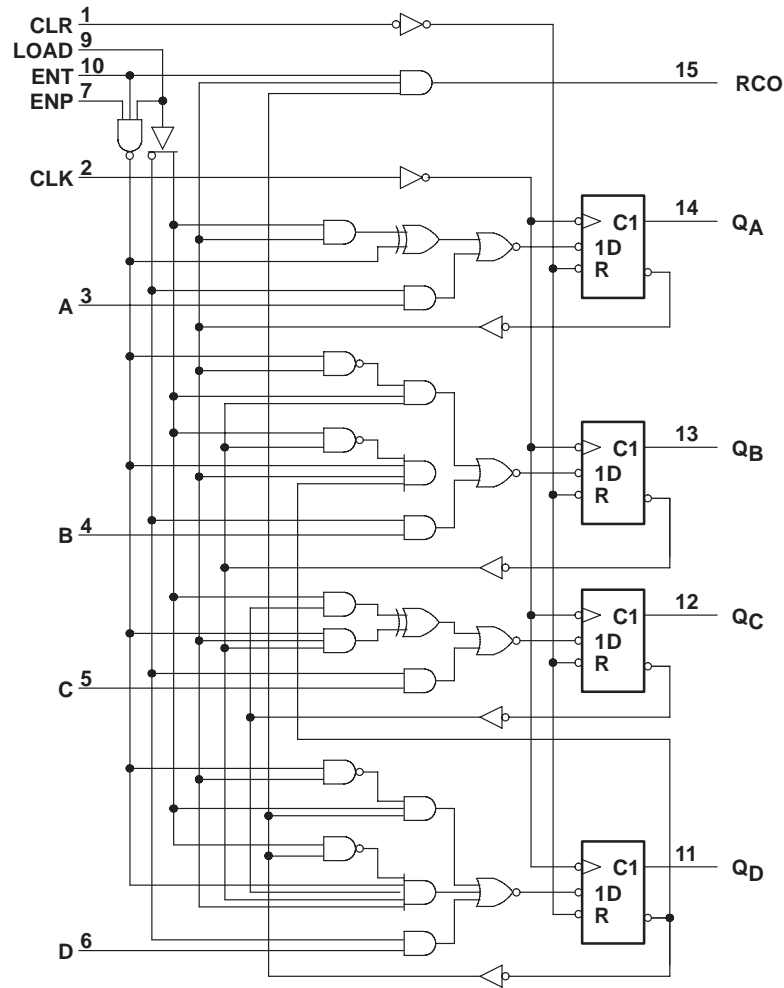

† These symbols are in accordance with ANSI/IEEE Std 91-1984 and IEC Publication 617-12. Pin numbers shown are for D, J, and N packages.

'ALS162B and 'AS162 decade counters are similar; however the clear is synchronous as shown for the 'ALS163B and 'AS163 binary counters.



# SN54ALS161B, SN54ALS163B, SN54AS161, SN54AS163 SN74ALS161B, SN74ALS163B, SN74AS161, SN74AS163 SYNCHRONOUS 4-BIT BINARY COUNTERS

SDAS024A - D2661, APRIL 1982 - REVISED MAY 1986

## logic symbols†

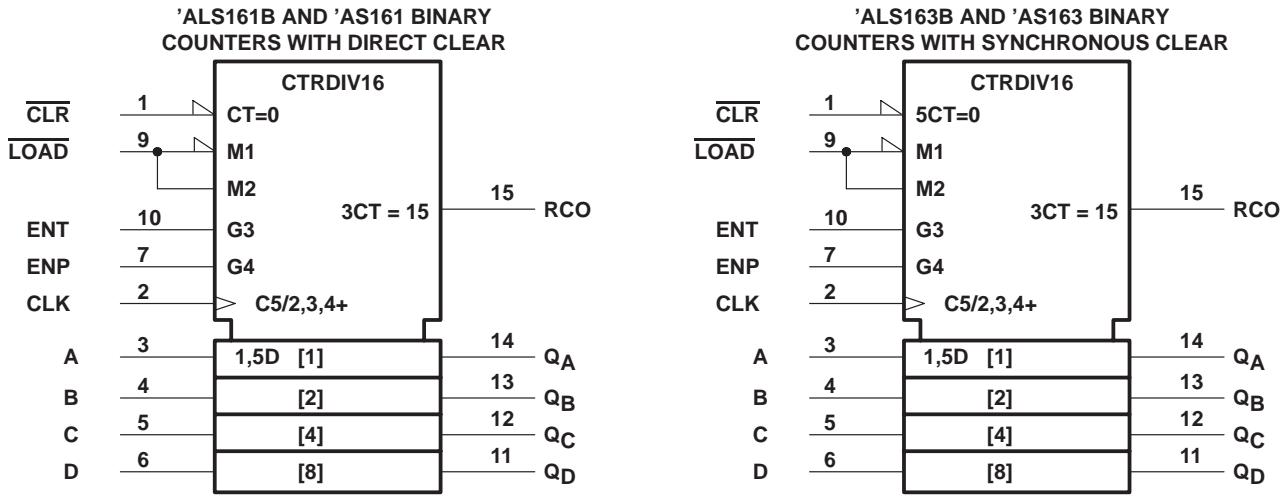

## 'ALS163B and 'AS163 logic diagram (positive logic)

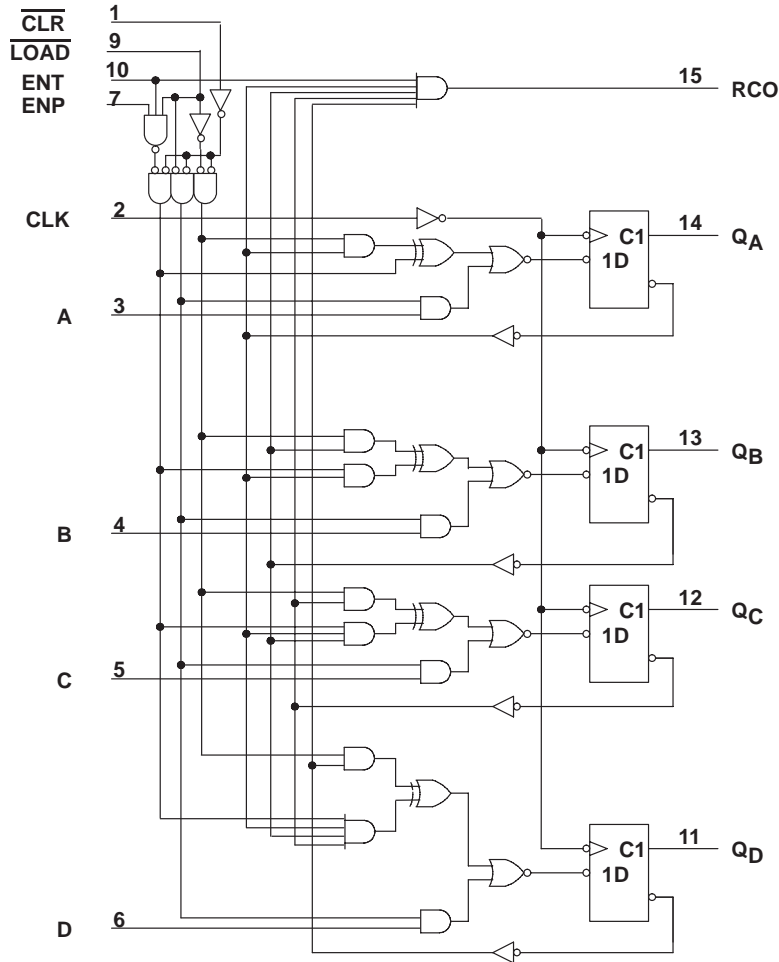

† These symbols are in accordance with ANSI/IEEE Std 91-1984 and IEC Publication 617-12.

Pin numbers shown are for D, J, and N packages.

'ALS161B and 'AS161 synchronous binary counters are similar; however the clear is asynchronous as shown for the 'ALS160B and 'AS160 decade counters.



POST OFFICE BOX 655303 • DALLAS, TEXAS 75265  
POST OFFICE BOX 1443 • HOUSTON, TEXAS 77001

# SN54ALS160B, SN54ALS162B, SN54AS160, SN54AS162 SN74ALS160B, SN74ALS162B, SN74AS160, SN74AS162 SYNCHRONOUS 4-BIT DECADE COUNTERS

SDAS024A – D2661, APRIL 1982 – REVISED MAY 1986

## typical clear, preset, count, and inhibit sequences

'ALS160B, 'AS160, 'ALS162B, 'AS162

Illustrated below is the following sequence:

1. Clear outputs to zero ('ALS160B and 'AS160 are asynchronous; 'ALS162B and 'AS1162 are synchronous)
2. Preset to BCD seven
3. Count to eight, nine, zero, one, two, and three
4. Inhibit

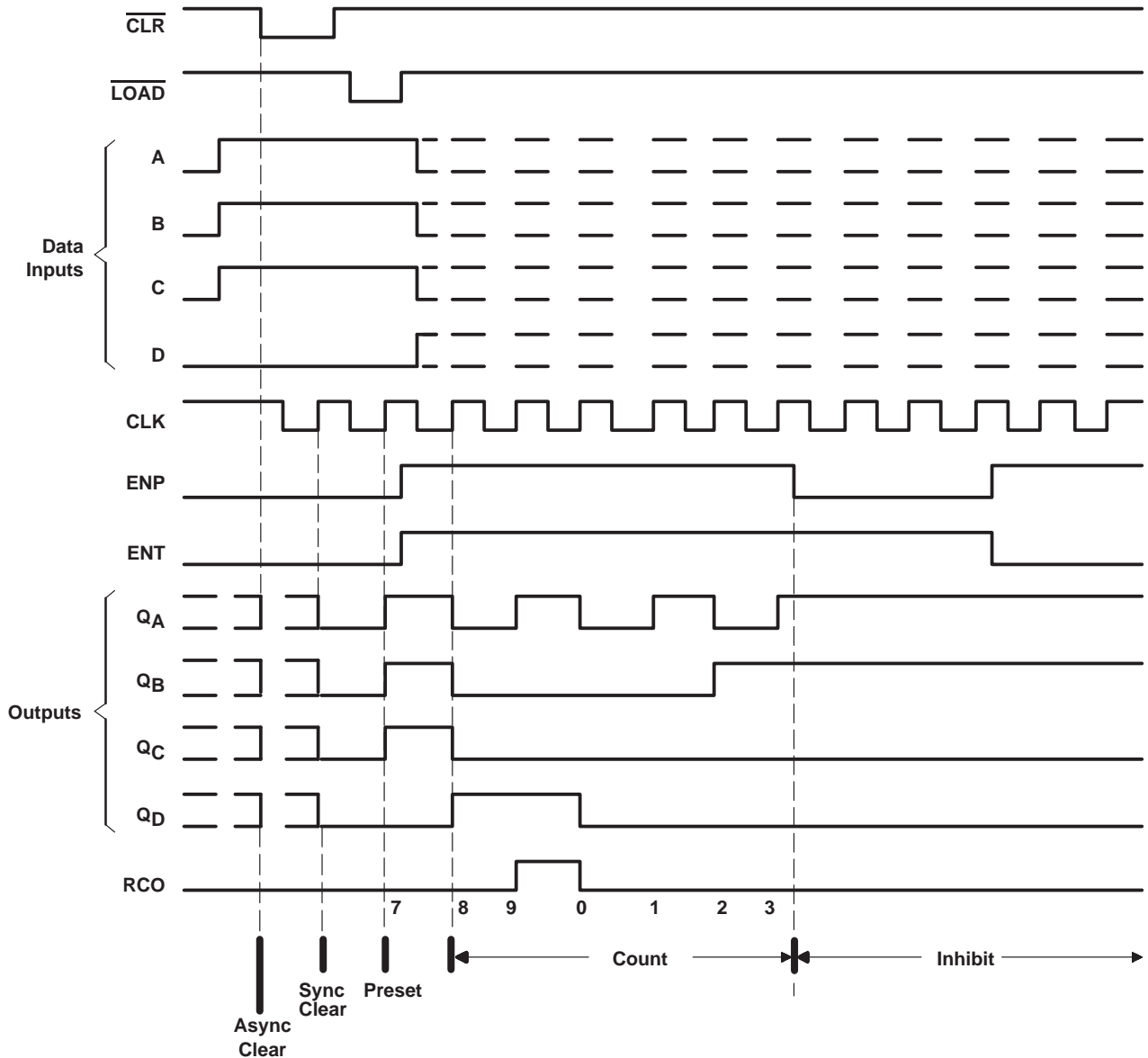

# SN54ALS161B, SN54ALS163B, SN54AS161, SN54AS163 SN74ALS161B, SN74ALS163B, SN74AS161, SN74AS163 SYNCHRONOUS 4-BIT BINARY COUNTERS

SDAS024A - D2661, APRIL 1982 - REVISED MAY 1986

## typical clear, preset, count, and inhibit sequences

'ALS161B, 'AS161, 'ALS163B, 'AS163

Illustrated below is the following sequence:

1. Clear outputs to zero ('ALS161B and 'AS161 are asynchronous; 'ALS163B and 'AS163 are synchronous)
2. Preset to binary twelve
3. Count to thirteen, fourteen, fifteen, zero, one, and two
4. Inhibit

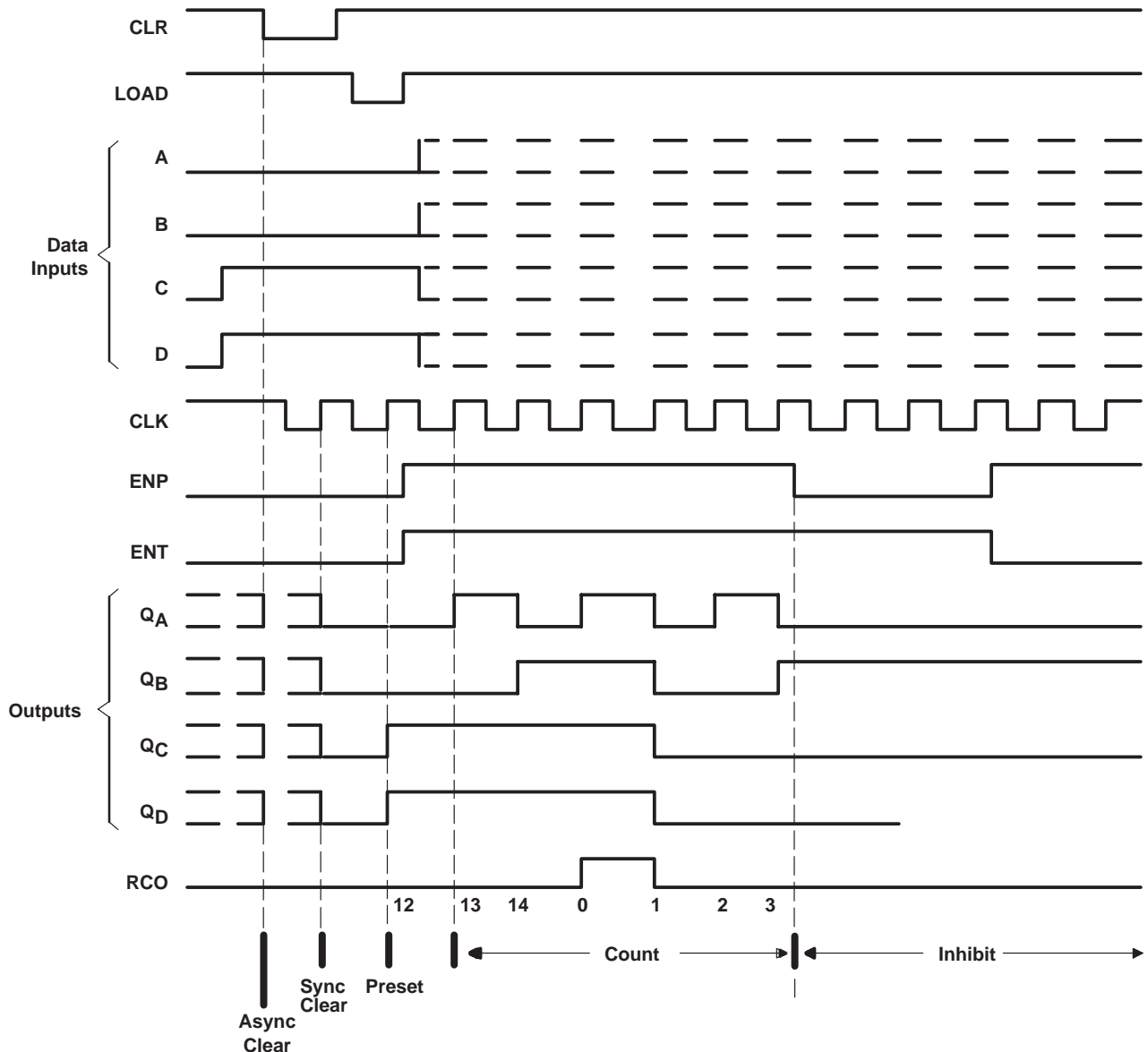

# SN54ALS160B THRU SN54ALS163B SN74ALS160B THRU SN74ALS163B SYNCHRONOUS 4-BIT DECADE COUNTERS

SDAS024A – D2661, APRIL 1982 – REVISED MAY 1986

## absolute maximum ratings over operating free-air temperature range (unless otherwise noted)

Supply voltage, $V_{CC}$	7 V
Input voltage	7 V
Operating free-air temperature range:	
SN54ALS160B thru SN54ALS163B	–55°C to 125°C
SN74ALS160B thru SN74ALS163B	0°C to 70°C
Storage temperature range	–65°C to 150°C

## recommended operating conditions

		SN54ALS160B THRU SN54ALS163B			SN74ALS160B THRU SN74ALS163B			UNIT
		MIN	NOM	MAX	MIN	NOM	MAX	
$V_{CC}$	Supply voltage	4.5	5	5.5	4.5	5	5.5	V
$V_{IH}$	High-level input voltage	2			2			V
$V_{IL}$	Low-level input voltage			0.7			0.8	V
$I_{OH}$	High-level output current			–0.4			–0.4	mA
$I_{OL}$	Low-level output current			4			8	mA
$f_{clock}$	Clock frequency	0		22	0		40	MHz
$t_w$	Pulse duration	CLR high or low		20	12.5		ns	
		'ALS160B, 'ALS161B CLR low		20	15			
$t_{su}$	Setup time before CLK $\uparrow$	A, B, C, D		50	15		ns	
		LOAD		20	15			
		ENP, ENT	'ALS160B, 'ALS161B	25	15			
			'ALS162B, 'ALS163B	20	15			
		'ALS160B, 'ALS161B	CLR inactive	10	10			
		'ALS162B, 'ALS163B	CLR low	20	15			
CLR high (inactive)	10		10					
$t_h$	Hold time, all synchronous inputs after CLK $\uparrow$	0			0		ns	
$T_A$	Operating free-air temperature	–55		125	0		70	°C

## electrical characteristics over recommended operating free-air temperature range (unless otherwise noted)

PARAMETER	TEST CONDITIONS	SN54ALS160B THRU SN54ALS163B			SN74ALS160B THRU SN74ALS163B			UNIT
		MIN	TYP $\dagger$	MAX	MIN	TYP $\dagger$	MAX	
$V_{IK}$	$V_{CC} = 4.5$ V, $I_I = -18$ mA			–1.5			–1.5	V
$V_{OH}$	$V_{CC} = 4.5$ V to 5.5 V, $I_{OH} = -0.4$ mA	$V_{CC}-2$			$V_{CC}-2$			V
$V_{OL}$	$V_{CC} = 4.5$ V, $I_{OL} = 4$ mA	0.25	0.4		0.25	0.4		V
	$V_{CC} = 4.5$ V, $I_{OL} = 8$ mA				0.35	0.5		
$I_I$	$V_{CC} = 5.5$ V, $V_I = 7$ V			0.1			0.1	mA
$I_{IH}$	$V_{CC} = 5.5$ V, $V_I = 2.7$ V			20			20	$\mu$ A
$I_{IL}$	$V_{CC} = 5.5$ V, $V_I = 0.4$ V			–0.2			–0.2	mA
$I_{O\ddagger}$	$V_{CC} = 5.5$ V, $V_O = 2.25$ V	–30		–112	–30		–112	mA
$I_{CC}$	$V_{CC} = 5.5$ V		12	21		12	21	mA

$\dagger$  All typical values are at  $V_{CC} = 5$  V,  $T_A = 25^\circ\text{C}$ .

$\ddagger$  The output conditions have been chosen to produce a current that closely approximates one half of the true short-circuit output current,  $I_{OS}$ .



**SN54ALS160B THRU SN54ALS163B  
SN74ALS160B THRU SN74ALS163B  
SYNCHRONOUS 4-BIT BINARY COUNTERS**

SDAS024A - D2661, APRIL 1982 - REVISED MAY 1986

**'ALS160B, 'ALS161B switching characteristics (see Note 1)**

PARAMETER	FROM (INPUT)	TO (OUTPUT)	V <sub>CC</sub> = 4.5 V to 5.5 V, C <sub>L</sub> = 50 pF, R <sub>L</sub> = 500 Ω, T <sub>A</sub> = MIN to MAX				UNIT
			SN54ALS160B SN54ALS161B		SN74ALS160B SN74ALS161B		
			MIN	MAX	MIN	MAX	
f <sub>max</sub>			22		40	MHz	
t <sub>PLH</sub>	CLK	RCO	5	34	5	20	ns
t <sub>PHL</sub>			5	27	5	20	
t <sub>PLH</sub>	CLK	Any Q	4	19	4	15	ns
t <sub>PHL</sub>			6	25	6	20	
t <sub>PLH</sub>	ENT	RCO	3	18	3	13	ns
t <sub>PHL</sub>			3	17	3	13	
t <sub>PHL</sub>	CLR	Any Q	8	27	8	24	ns
t <sub>PHL</sub>	CLR	RCO	11	32	11	23	ns

**'ALS162B, 'ALS163B switching characteristics (see Note 1)**

PARAMETER	FROM (INPUT)	TO (OUTPUT)	V <sub>CC</sub> = 4.5 V to 5.5 V, C <sub>L</sub> = 50 pF, R <sub>L</sub> = 500 Ω, T <sub>A</sub> = MIN to MAX				UNIT
			SN54ALS162B SN54ALS163B		SN74ALS162B SN74ALS163B		
			MIN	MAX	MIN	MAX	
f <sub>max</sub>			35		40	MHz	
t <sub>PLH</sub>	CLK	RCO	5	25	5	20	ns
t <sub>PHL</sub>			5	25	5	20	
t <sub>PLH</sub>	CLK	Any Q	4	18	4	15	ns
t <sub>PHL</sub>			6	25	6	20	
t <sub>PLH</sub>	ENT	RCO	3	16	3	13	ns
t <sub>PHL</sub>			3	16	3	13	

NOTE 1: Load circuit and voltage waveforms are shown in Section 1.



# SN54AS160 THRU SN54AS163 SN74AS160 THRU SN74AS163 SYNCHRONOUS 4-BIT DECADE COUNTERS

SDAS024A – D2661, APRIL 1982 – REVISED MAY 1986

## absolute maximum ratings over operating free-air temperature range (unless otherwise noted)

Supply voltage, $V_{CC}$	7 V
Input voltage	7 V
Operating free-air temperature range:	SN54AS160 thru SN54AS163 $-55^{\circ}\text{C}$ to $125^{\circ}\text{C}$ SN74AS160 thru SN74AS163 $0^{\circ}\text{C}$ to $70^{\circ}\text{C}$
Storage temperature range	$-65^{\circ}\text{C}$ to $150^{\circ}\text{C}$

## recommended operating conditions

		SN54AS160 THRU SN54AS163			SN74AS160 THRU SN74AS163			UNIT
		MIN	NOM	MAX	MIN	NOM	MAX	
$V_{CC}$	Supply voltage	4.5	5	5.5	4.5	5	5.5	V
$V_{IH}$	High-level input voltage	2			2			V
$V_{IL}$	Low-level input voltage			0.8			0.8	V
$I_{OH}$	High-level output current			-2			-2	mA
$I_{OL}$	Low-level output current			20			20	mA
$f_{\text{clock}}$	Clock frequency	0		65	0		75	MHz
$t_w$	Pulse duration	CLR high or low		7.7		6.7		ns
		'ALS160, 'ALS161 CLR low		10		8		
$t_{su}$	Setup time before CLK $\uparrow$	A, B, C, D		10		8		ns
		LOAD		10		8		
		ENP, ENT		10		8		
		'ALS160, 'ALS161 CLR inactive		10		8		
		'ALS162, 'ALS163		CLR low	14		12	
CLR high (inactive)	10				9			
$t_h$	Hold time, all synchronous inputs after CLK $\uparrow$	2			0			ns
$T_A$	Operating free-air temperature	-55		125	0		70	$^{\circ}\text{C}$

## electrical characteristics over recommended operating free-air temperature range (unless otherwise noted)

PARAMETER		TEST CONDITIONS		SN54AS160 THRU SN54AS163			SN74AS160 THRU SN74AS163			UNIT
				MIN	TYP $\dagger$	MAX	MIN	TYP $\dagger$	MAX	
$V_{IK}$		$V_{CC} = 4.5\text{ V}$ ,	$I_I = -18\text{ mA}$			-1.2			-1.2	V
$V_{OH}$		$V_{CC} = 4.5\text{ V}$ to $5.5\text{ V}$ ,	$I_{OH} = -2\text{ mA}$	$V_{CC} - 2$			$V_{CC} - 2$			V
$V_{OL}$		$V_{CC} = 4.5\text{ V}$ ,	$I_{OL} = 20\text{ mA}$		0.25	0.5		0.25	0.5	V
$I_I$	LOAD	$V_{CC} = 5.5\text{ V}$ ,	$V_I = 7\text{ V}$			0.3			0.3	mA
	ENT					0.2			0.2	
	All other					0.1			0.1	
$I_{IH}$	LOAD	$V_{CC} = 5.5\text{ V}$ ,	$V_I = 2.7\text{ V}$			60			60	$\mu\text{A}$
	ENT					40			40	
	All other					20			20	
$I_{IL}$	LOAD	$V_{CC} = 5.5\text{ V}$ ,	$V_I = 0.4\text{ V}$			-1.5			-1.5	mA
	ENT					-1			-1	
	All other					-0.5			-0.5	
$I_{O}^{\ddagger}$		$V_{CC} = 5.5\text{ V}$ ,	$V_O = 2.25\text{ V}$	-30		-112	-30		-112	mA
$I_{CC}$		$V_{CC} = 5.5\text{ V}$			35	53		35	53	mA

$\dagger$  All typical values are at  $V_{CC} = 5\text{ V}$ ,  $T_A = 25^{\circ}\text{C}$ .

$\ddagger$  The output conditions have been chosen to produce a current that closely approximates one half of the true short-circuit output current,  $I_{OS}$ .



# SN54AS160 THRU SN54AS163 SN74AS160 THRU SN74AS163 SYNCHRONOUS 4-BIT BINARY COUNTERS

SDAS024A - D2661, APRIL 1982 - REVISED MAY 1986

## 'AS160, 'AS161 switching characteristics (see Note 1)

PARAMETER	FROM (INPUT)	TO (OUTPUT)	V <sub>CC</sub> = 4.5 V to 5.5 V, C <sub>L</sub> = 50 pF, C <sub>L</sub> = 50 pF, R <sub>L</sub> = 500 Ω, T <sub>A</sub> = MIN to MAX				UNIT
			SN54AS160 SN54AS161		SN74AS160 SN74AS161		
			MIN	MAX	MIN	MAX	
f <sub>max</sub>			65		75	MHz	
t <sub>PHL</sub>	CLK	RCO	2	14	2	12.5	ns
t <sub>PLH</sub>		RCO (with LOAD high)	1	8.5	1	8	
t <sub>PLH</sub>		RCO (with LOAD low)	3	17.5	3	16.5	
t <sub>PLH</sub>	CLK	Any Q	1	7.5	1	7	ns
t <sub>PHL</sub>			2	14	2	13	
t <sub>PLH</sub>	ENT	RCO	1.5	10	1.5	9	ns
t <sub>PHL</sub>			1	9.5	1	8.5	
t <sub>PHL</sub>	CLR	Any Q	2	14	2	13	ns
t <sub>PHL</sub>	CLR	RCO	2	14	2	12.5	ns

## 'AS162, 'AS163 switching characteristics (see Note 1)

PARAMETER	FROM (INPUT)	TO (OUTPUT)	V <sub>CC</sub> = 4.5 V to 5.5 V, C <sub>L</sub> = 50 pF, R <sub>L</sub> = 500 Ω, T <sub>A</sub> = MIN to MAX				UNIT
			SN54AS162 SN54AS163		SN74AS162 SN74AS163		
			MIN	MAX	MIN	MAX	
f <sub>max</sub>			65		75	MHz	
t <sub>PHL</sub>	CLK	RCO	2	14	2	12.5	ns
t <sub>PLH</sub>		RCO (with LOAD high)	1	8.5	1	8	
t <sub>PLH</sub>		RCO (with LOAD low)	3	17.5	3	16.5	
t <sub>PLH</sub>	CLK	Any Q	1	7.5	1	7	ns
t <sub>PHL</sub>			2	14	2	13	
t <sub>PLH</sub>	ENT	RCO	1.5	10	1.5	9	ns
t <sub>PHL</sub>			1	9.5	1	8.5	

NOTE 1: Load circuit and voltage waveforms are shown in Section 1.



# SN54ALS160B THRU SN54ALS163B, SN54AS160 THRU SN54AS163 SN74ALS160B THRU SN74ALS163B, SN74AS160 THRU SN74AS163 SYNCHRONOUS 4-BIT DECADE COUNTERS

SDAS024A – D2661, APRIL 1982 – REVISED MAY 1986

## APPLICATION INFORMATION

### N-bit synchronous counters

This application demonstrates how the ripple mode carry circuit (Figure 1) and the carry-look-ahead circuit (Figure 2) can be used to implement a high-speed N-bit counter. The 'ALS160B, 'AS160, 'ALS162B, and 'AS162 will count in BCD and the 'ALS161B, 'AS161, 'ALS163B, and 'AS163 will count in binary. When additional stages are added, the  $f_{MAX}$  decreases in Figure 1, but remains unchanged in Figure 2.

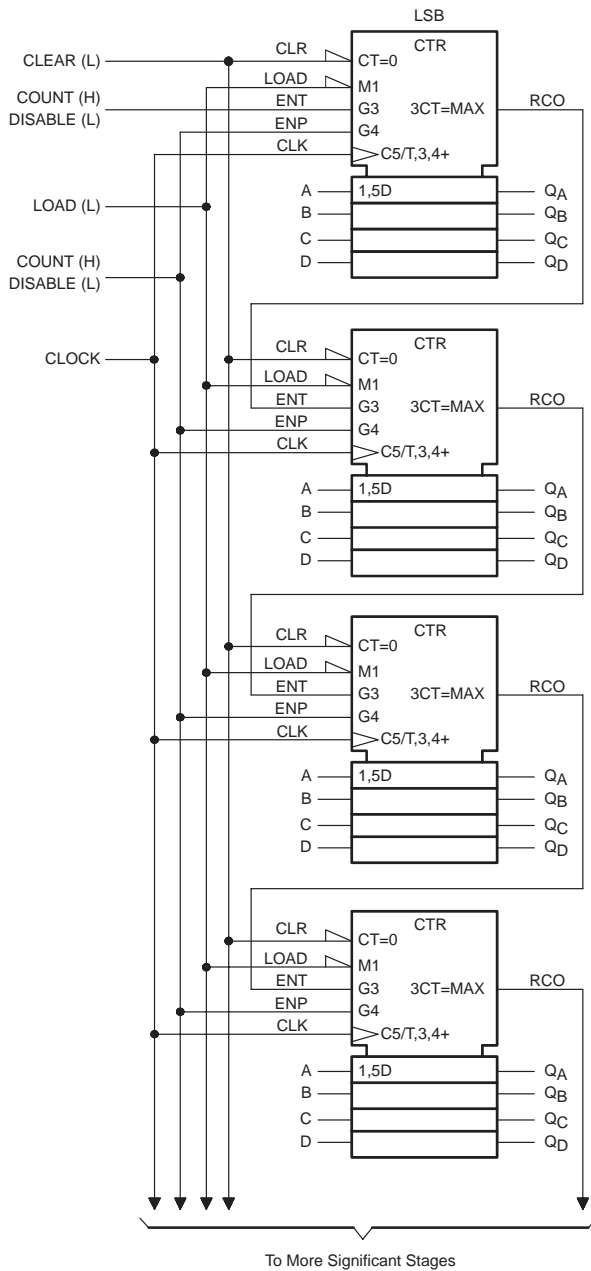

$$f_{MAX} = 1/(\text{CLK to RCO } t_{PLH}) + (\text{ENT to RCO } t_{PLH}) (N-2) + (\text{ENT } t_{su})$$

Figure 1. Ripple Mode Carry Circuit

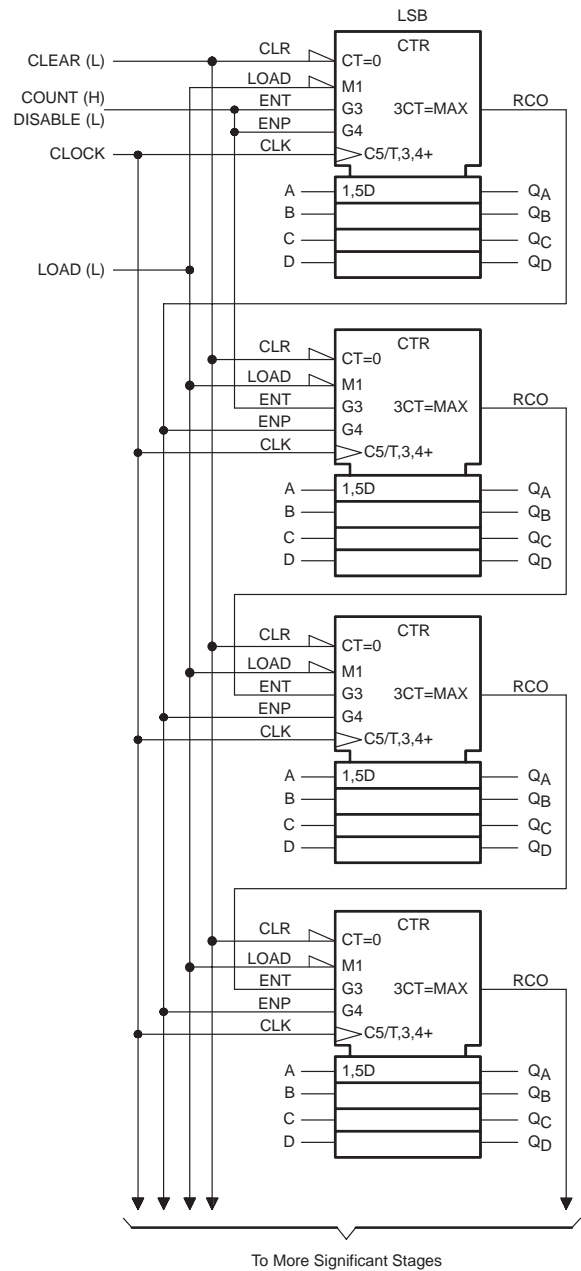

$$f_{MAX} = 1/(\text{CLK to RCO } t_{PLH}) + (\text{ENP } t_{su})$$

Figure 2. Carry-Look-Ahead Circuit

**TAPE AND REEL INFORMATION**

**QUADRANT ASSIGNMENTS FOR PIN 1 ORIENTATION IN TAPE**

\*All dimensions are nominal

Device	Package Type	Package Drawing	Pins	SPQ	Reel Diameter (mm)	Reel Width W1 (mm)	A0 (mm)	B0 (mm)	K0 (mm)	P1 (mm)	W (mm)	Pin1 Quadrant
SN74ALS161BDR	SOIC	D	16	2500	330.0	16.4	6.5	10.3	2.1	8.0	16.0	Q1
SN74ALS161BNSR	SO	NS	16	2000	330.0	16.4	8.2	10.5	2.5	12.0	16.0	Q1
SN74ALS163BDR	SOIC	D	16	2500	330.0	16.4	6.5	10.3	2.1	8.0	16.0	Q1
SN74ALS163BNSR	SO	NS	16	2000	330.0	16.4	8.2	10.5	2.5	12.0	16.0	Q1
SN74AS161NSR	SO	NS	16	2000	330.0	16.4	8.2	10.5	2.5	12.0	16.0	Q1

**TAPE AND REEL BOX DIMENSIONS**

\*All dimensions are nominal

Device	Package Type	Package Drawing	Pins	SPQ	Length (mm)	Width (mm)	Height (mm)
SN74ALS161BDR	SOIC	D	16	2500	333.2	345.9	28.6
SN74ALS161BNSR	SO	NS	16	2000	346.0	346.0	33.0
SN74ALS163BDR	SOIC	D	16	2500	333.2	345.9	28.6
SN74ALS163BNSR	SO	NS	16	2000	346.0	346.0	33.0
SN74AS161NSR	SO	NS	16	2000	346.0	346.0	33.0

## IMPORTANT NOTICE

Texas Instruments Incorporated and its subsidiaries (TI) reserve the right to make corrections, modifications, enhancements, improvements, and other changes to its products and services at any time and to discontinue any product or service without notice. Customers should obtain the latest relevant information before placing orders and should verify that such information is current and complete. All products are sold subject to TI's terms and conditions of sale supplied at the time of order acknowledgment.

TI warrants performance of its hardware products to the specifications applicable at the time of sale in accordance with TI's standard warranty. Testing and other quality control techniques are used to the extent TI deems necessary to support this warranty. Except where mandated by government requirements, testing of all parameters of each product is not necessarily performed.

TI assumes no liability for applications assistance or customer product design. Customers are responsible for their products and applications using TI components. To minimize the risks associated with customer products and applications, customers should provide adequate design and operating safeguards.

TI does not warrant or represent that any license, either express or implied, is granted under any TI patent right, copyright, mask work right, or other TI intellectual property right relating to any combination, machine, or process in which TI products or services are used. Information published by TI regarding third-party products or services does not constitute a license from TI to use such products or services or a warranty or endorsement thereof. Use of such information may require a license from a third party under the patents or other intellectual property of the third party, or a license from TI under the patents or other intellectual property of TI.

Reproduction of TI information in TI data books or data sheets is permissible only if reproduction is without alteration and is accompanied by all associated warranties, conditions, limitations, and notices. Reproduction of this information with alteration is an unfair and deceptive business practice. TI is not responsible or liable for such altered documentation. Information of third parties may be subject to additional restrictions.

Resale of TI products or services with statements different from or beyond the parameters stated by TI for that product or service voids all express and any implied warranties for the associated TI product or service and is an unfair and deceptive business practice. TI is not responsible or liable for any such statements.

TI products are not authorized for use in safety-critical applications (such as life support) where a failure of the TI product would reasonably be expected to cause severe personal injury or death, unless officers of the parties have executed an agreement specifically governing such use. Buyers represent that they have all necessary expertise in the safety and regulatory ramifications of their applications, and acknowledge and agree that they are solely responsible for all legal, regulatory and safety-related requirements concerning their products and any use of TI products in such safety-critical applications, notwithstanding any applications-related information or support that may be provided by TI. Further, Buyers must fully indemnify TI and its representatives against any damages arising out of the use of TI products in such safety-critical applications.

TI products are neither designed nor intended for use in military/aerospace applications or environments unless the TI products are specifically designated by TI as military-grade or "enhanced plastic." Only products designated by TI as military-grade meet military specifications. Buyers acknowledge and agree that any such use of TI products which TI has not designated as military-grade is solely at the Buyer's risk, and that they are solely responsible for compliance with all legal and regulatory requirements in connection with such use.

TI products are neither designed nor intended for use in automotive applications or environments unless the specific TI products are designated by TI as compliant with ISO/TS 16949 requirements. Buyers acknowledge and agree that, if they use any non-designated products in automotive applications, TI will not be responsible for any failure to meet such requirements.

Following are URLs where you can obtain information on other Texas Instruments products and application solutions:

<b>Products</b>		<b>Applications</b>	
Amplifiers	<a href="http://amplifier.ti.com">amplifier.ti.com</a>	Audio	<a href="http://www.ti.com/audio">www.ti.com/audio</a>
Data Converters	<a href="http://dataconverter.ti.com">dataconverter.ti.com</a>	Automotive	<a href="http://www.ti.com/automotive">www.ti.com/automotive</a>
DLP® Products	<a href="http://www.dlp.com">www.dlp.com</a>	Communications and Telecom	<a href="http://www.ti.com/communications">www.ti.com/communications</a>
DSP	<a href="http://dsp.ti.com">dsp.ti.com</a>	Computers and Peripherals	<a href="http://www.ti.com/computers">www.ti.com/computers</a>
Clocks and Timers	<a href="http://www.ti.com/clocks">www.ti.com/clocks</a>	Consumer Electronics	<a href="http://www.ti.com/consumer-apps">www.ti.com/consumer-apps</a>
Interface	<a href="http://interface.ti.com">interface.ti.com</a>	Energy	<a href="http://www.ti.com/energy">www.ti.com/energy</a>
Logic	<a href="http://logic.ti.com">logic.ti.com</a>	Industrial	<a href="http://www.ti.com/industrial">www.ti.com/industrial</a>
Power Mgmt	<a href="http://power.ti.com">power.ti.com</a>	Medical	<a href="http://www.ti.com/medical">www.ti.com/medical</a>
Microcontrollers	<a href="http://microcontroller.ti.com">microcontroller.ti.com</a>	Security	<a href="http://www.ti.com/security">www.ti.com/security</a>
RFID	<a href="http://www.ti-rfid.com">www.ti-rfid.com</a>	Space, Avionics & Defense	<a href="http://www.ti.com/space-avionics-defense">www.ti.com/space-avionics-defense</a>
RF/IF and ZigBee® Solutions	<a href="http://www.ti.com/lprf">www.ti.com/lprf</a>	Video and Imaging	<a href="http://www.ti.com/video">www.ti.com/video</a>
		Wireless	<a href="http://www.ti.com/wireless-apps">www.ti.com/wireless-apps</a>

Mailing Address: Texas Instruments, Post Office Box 655303, Dallas, Texas 75265  
Copyright © 2010, Texas Instruments Incorporated