

具有三态输出的 SNx4AHCT240 八通道反相缓冲器/驱动器

1 特性

- 输入与 TTL 电压兼容
- 闩锁性能超过 JESD 17 所规定的 250mA
- 对于符合 MIL-PRF-38535 标准的产品，所有参数均经过测试，除非另外注明。对于所有其他产品，生产流程不一定包含对所有参数的测试。

2 应用

- 网络交换机
- 医疗和健身
- 电视
- 电力基础设施

3 说明

SNx4AHCT240 八通道缓冲器/驱动器设计用于提高三态存储器地址驱动器、时钟驱动器以及总线导向接收器和发射器的性能和密度。

器件信息⁽¹⁾

器件型号	封装	封装尺寸 (标称值)
SN74AHCT240DB	SSOP (20)	7.50mm × 5.30mm
SN74AHCT240NS	SO (20)	12.60mm × 5.30mm
SN74AHCT240PW	薄型小外形尺寸封装 (TSSOP) (20)	6.50mm × 4.40mm
SN74AHCT240DW	SOIC (20)	12.80mm × 7.50mm
SN74AHCT240N	PDIP (20)	25.40mm × 6.35mm

(1) 如需了解所有可用封装，请参阅数据表末尾的可订购产品附录。

简化原理图

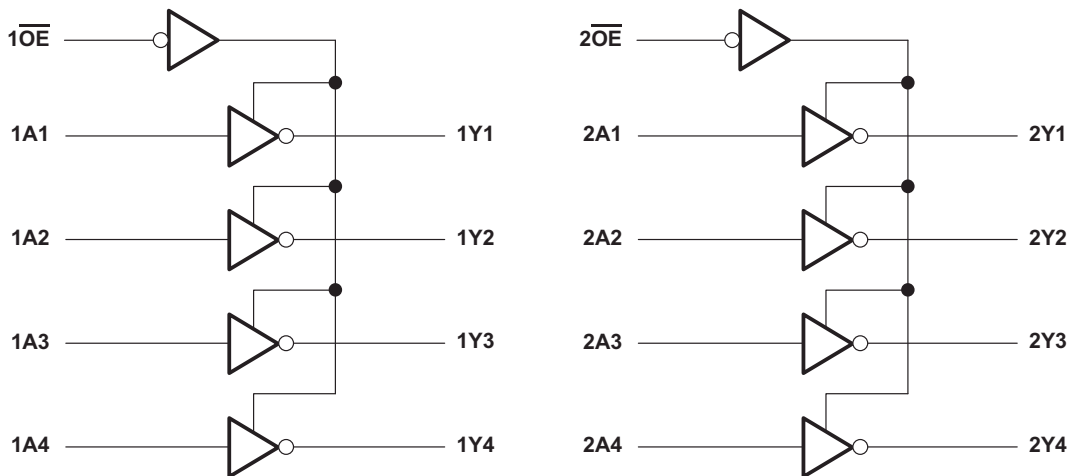

Copyright © 2016, Texas Instruments Incorporated



目录

1	特性	1	9.1	Overview	10
2	应用	1	9.2	Functional Block Diagram	10
3	说明	1	9.3	Feature Description	10
4	修订历史记录	2	9.4	Device Functional Modes	10
5	Pin Configuration and Functions	3	10	Application and Implementation	11
6	Specifications	4	10.1	Application Information	11
6.1	Absolute Maximum Ratings	4	10.2	Typical Application	11
6.2	ESD Ratings	4	11	Power Supply Recommendations	12
6.3	Recommended Operating Conditions	5	12	Layout	12
6.4	Thermal Information	5	12.1	Layout Guidelines	12
6.5	Electrical Characteristics	5	12.2	Layout Example	12
6.6	Switching Characteristics	6	13	器件和文档支持	13
6.7	Noise Characteristics	6	13.1	社区资源	13
6.8	Operating Characteristics	6	13.2	相关链接	13
7	Typical Characteristics	7	13.3	商标	13
8	Parameter Measurement Information	8	13.4	静电放电警告	13
9	Detailed Description	10	13.5	Glossary	13
			14	机械、封装和可订购信息	13

4 修订历史记录

Changes from Revision M (April 2016) to Revision N	Page
• Added junction temperature to <i>Absolute Maximum Ratings</i> table	4
• Moved storage temperature from <i>ESD Ratings</i> table to <i>Absolute Maximum Ratings</i> table	4
• 已更改 the <i>Function</i> table layout	10

Changes from Revision L (October 2014) to Revision M	Page
• Changed <i>Handling Ratings</i> table title to <i>ESD Ratings</i>	4
• Added –40°C to 85°C to SN74AHCT240 header in <i>Electrical Characteristics</i> table	5
• Added –40°C to 85°C to SN74AHCT240 header in <i>Switching Characteristics</i> table	6

Changes from Revision K (July 2003) to Revision L	Page
• 将文档格式更新成了新的 TI 数据表格式。	1
• 已删除 订购信息表。	1
• 已添加 将“军用免责声明”添加到 特性 列表。	1
• 已添加 应用”	1
• Extended operating temperature range to 125°C	5
• Added <i>Thermal Information</i> table	5
• Added –40°C to 125°C for SN74AHCT240 in the <i>Electrical Specifications</i> table.	5
• Added –40°C to 125°C for SN74AHCT240 in the <i>Switching Characteristics</i> table.	6
• 已添加 Detailed Description section.	10
• 已添加 <i>Application and Implementation</i> section.	11
• 已添加 Power Supply Recommendations and Layout sections.	12

5 Pin Configuration and Functions

SN54AHCT240, J or W Package
SN74AHCT240, DB, DGV, DW, N, NS, or PW Package (20) Pin
Top View

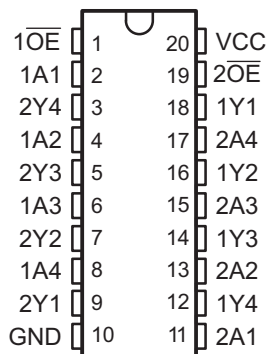

SN54AHCT240 FK Package (20) Pin
Top View

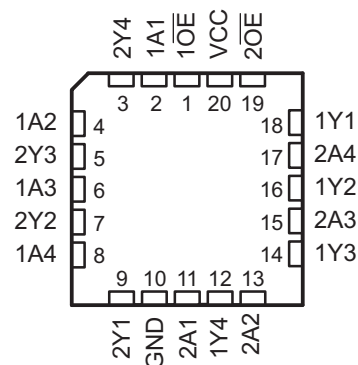

Pin Functions

PIN		I/O	DESCRIPTION
NAME	NO.		
$\overline{1OE}$	1	I	Output Enable 1
1A1	2	I	1A1 Input
2Y4	3	O	2Y4 Output
1A2	4	I	1A2 Input
2Y3	5	O	2Y3 Output
1A3	6	I	1A3 Input
2Y2	7	O	2Y2 Output
1A4	8	I	1A4 Input
2Y1	9	O	2Y1 Output
GND	10	—	Ground Pin
2A1	11	I	2A1 Input
1Y4	12	O	1Y4 Output
2A2	13	I	2A2 Input
1Y3	14	O	1Y3 Output
2A3	15	I	2A3 Input
1Y2	16	O	1Y2 Output
2A4	17	I	2A4 Input
1Y1	18	O	1Y1 Output
$\overline{2OE}$	19	I	Output Enable 2
VCC	20	—	Power Pin

6 Specifications

6.1 Absolute Maximum Ratings

over operating free-air temperature range (unless otherwise noted)⁽¹⁾

		MIN	MAX	UNIT
Supply voltage, V_{CC}		-0.5	7	V
Input voltage, V_I ⁽²⁾		-0.5	7	V
Output voltage, V_O ⁽²⁾		-0.5	$V_{CC} + 0.5$	V
Input clamp current, I_{IK}	$V_I < 0$		-20	mA
Output clamp current, I_{OK}	$V_O < 0$ or $V_O > V_{CC}$		± 20	mA
Continuous output current, I_O	$V_O = 0$ to V_{CC}		± 25	mA
Continuous current through V_{CC} or GND			± 75	mA
Junction temperature, T_J			150	°C
Storage temperature, T_{stg}		-65	150	°C

- (1) Stresses beyond those listed under *Absolute Maximum Ratings* may cause permanent damage to the device. These are stress ratings only, which do not imply functional operation of the device at these or any other conditions beyond those indicated under *Recommended Operating Conditions*. Exposure to absolute-maximum-rated conditions for extended periods may affect device reliability.
- (2) The input and output voltage ratings may be exceeded if the input and output current ratings are observed.

6.2 ESD Ratings

		MIN	MAX	UNIT
$V_{(ESD)}$ Electrostatic discharge	Human body model (HBM), per ANSI/ESDA/JEDEC JS-001, all pins ⁽¹⁾	0	1000	V
	Charged device model (CDM), per JEDEC specification JESD22-C101, all pins ⁽²⁾	0	2000	

- (1) JEDEC document JEP155 states that 500-V HBM allows safe manufacturing with a standard ESD control process.
- (2) JEDEC document JEP157 states that 250-V CDM allows safe manufacturing with a standard ESD control process.

6.3 Recommended Operating Conditions

 over operating free-air temperature range (unless otherwise noted)⁽¹⁾

		SN54AHCT240		SN74AHCT240		UNIT
		MIN	MAX	MIN	MAX	
V _{CC}	Supply voltage	4.5	5.5	4.5	5.5	V
V _{IH}	High-level input voltage	2		2		V
V _{IL}	Low-level Input voltage		0.8		0.8	V
V _I	Input voltage	0	5.5	0	5.5	V
V _O	Output voltage	0	V _{CC}	0	V _{CC}	V
I _{OH}	High-level output current		-8		-8	mA
I _{OL}	Low-level output current		8		8	mA
T _A	Operating free-air temperature	-55	125	-40	125	°C

(1) All unused inputs of the device must be held at V_{CC} or GND to ensure proper device operation. See the [Implications of Slow or Floating CMOS Inputs application report](#).

6.4 Thermal Information

THERMAL METRIC ⁽¹⁾	SN74AHCT240					UNIT	
	DW	DB	N	NS	PW		
	20 PINS	20 PINS	20 PINS	20 PINS	20 PINS		
R _{θJA}	Junction-to-ambient thermal resistance	83.0	99.9	54.9	80.4	105.4	°C/W
R _{θJC(top)}	Junction-to-case (top) thermal resistance	48.9	61.7	41.7	46.9	39.5	
R _{θJB}	Junction-to-board thermal resistance	50.5	55.2	35.8	47.9	56.4	
ψ _{JT}	Junction-to-top characterization parameter	21.1	22.6	27.9	19.9	3.1	
ψ _{JB}	Junction-to-board characterization parameter	50.1	54.8	35.7	47.5	55.8	

(1) For more information about traditional and new thermal metrics, see the [IC Package Thermal Metrics application report](#).

6.5 Electrical Characteristics

over recommended operating free-air temperature range (unless otherwise noted)

PARAMETER	TEST CONDITIONS	T _A = 25°C			SN54AHCT240		-40°C to 85°C SN74AHCT240		-40°C to 125°C SN74AHCT240		UNIT
		MIN	TYP	MAX	MIN	MAX	MIN	MAX	MIN	MAX	
V _{OH}	High-level output voltage	I _{OH} = -50 μA, V _{CC} = 4.5 V	4.4	4.5	4.4		4.4		4.4		V
		I _{OH} = -8 mA, V _{CC} = 4.5 V	3.94		3.8		3.8		3.8		
V _{OL}	Low-level output voltage	I _{OL} = 50 μA, V _{CC} = 4.5 V			0.1		0.1		0.1		V
		I _{OL} = 8 mA, V _{CC} = 4.5 V			0.36		0.44		0.44		
I _{OZ}	High-impedance-state output current	V _O = V _{CC} or GND V _{CC} = 5.5 V			±0.25		±2.5		±2.5		μA
I _I	Inflection-point current	V _I = 5.5 V or GND V _{CC} = 0 V to 5.5 V			±0.1		±1 ⁽¹⁾		±1		μA
I _{CC}	Supply current	V _I = V _{CC} or GND I _O = 0, V _{CC} = 5.5 V			4		40		40		μA
ΔI _{CC} ⁽²⁾	Supply current change	One input at 3.4 V other inputs at V _{CC} or GND V _{CC} = 5.5 V			1.35		1.5		1.5		mA
C _i	Input capacitance	V _I = V _{CC} or GND V _{CC} = 5.5 V		2.5	10				10		pF
C _o	Output capacitance	V _O = V _{CC} or GND V _{CC} = 5.5 V		3							pF

(1) On products compliant to MIL-PRF-38535, this parameter is not production tested at V_{CC} = 0 V.

(2) This is the increase in supply current for each input at one of the specified TTL voltage levels, rather than 0 V or V_{CC}.

6.6 Switching Characteristics

over recommended operating free-air temperature range, $V_{CC} = 5\text{ V} \pm 0.5\text{ V}$ (unless otherwise noted) (see [Parameter Measurement Information](#) section)

PARAMETER	TEST CONDITIONS		$T_A = 25^\circ\text{C}$		SN54AHCT240		-40°C to 85°C SN74AHCT240		-40°C to 125°C SN74AHCT240		UNIT
			TYP	MAX	MIN	MAX	MIN	MAX	MIN	MAX	
t_{PLH} Propagation delay time (low-to-high output)	A-to-Y	$C_L = 15\text{ pF}$	5.4 ⁽¹⁾	7.4 ⁽¹⁾	1 ⁽¹⁾	8.5 ⁽¹⁾	1	8.5	1	9.5	ns
t_{PHL} Propagation delay time (high-to-low output)			5.4 ⁽¹⁾	7.4 ⁽¹⁾	1 ⁽¹⁾	8.5 ⁽¹⁾	1	8.5	1	9.5	
t_{PZH} Enable time (to the high level)	\overline{OE} -to-Y	$C_L = 15\text{ pF}$	7.7 ⁽¹⁾	10.4 ⁽¹⁾	1 ⁽¹⁾	12 ⁽¹⁾	1	12	1	13	ns
t_{PZL} Enable time (to the low level)			7.7 ⁽¹⁾	10.4 ⁽¹⁾	1 ⁽¹⁾	12 ⁽¹⁾	1	12	1	13	
t_{PHZ} Disable time (from high level)	\overline{OE} -to-Y	$C_L = 15\text{ pF}$	8.3 ⁽¹⁾	10.4 ⁽¹⁾	1 ⁽¹⁾	12 ⁽¹⁾	1	12	1	13	ns
t_{PLZ} Disable time (from low level)			8.3 ⁽¹⁾	10.4 ⁽¹⁾	1 ⁽¹⁾	12 ⁽¹⁾	1	12	1	13	
t_{PLH} Propagation delay time (low-to-high output)	A-to-Y	$C_L = 50\text{ pF}$	5.9	8.4	1	9.5	1	9.5	1	10.5	ns
t_{PHL} Propagation delay time (high-to-low output)			5.9	8.4	1	9.5	1	9.5	1	10.5	
t_{PZH} Enable time (to the high level)	\overline{OE} -to-Y	$C_L = 50\text{ pF}$	8.2	11.4	1	13	1	13	1	14	ns
t_{PZL} Enable time (to the low level)			8.2	11.4	1	13	1	13	1	14	
t_{PHZ} Disable time (from high level)	\overline{OE} -to-Y	$C_L = 50\text{ pF}$	8.8	11.4	1	13	1	13	1	14	ns
t_{PLZ} Disable time (from low level)			8.8	11.4	1	13	1	13	1	14	
$t_{sk(o)}$ Skew (time), output		$C_L = 50\text{ pF}$		1 ⁽²⁾		1		1		1	ns

(1) On products compliant to MIL-PRF-38535, this parameter is not production tested.

(2) On products compliant to MIL-PRF-38535, this parameter does not apply.

6.7 Noise Characteristics

$V_{CC} = 5\text{ V}$, $C_L = 50\text{ pF}$, $T_A = 25^\circ\text{C}$ ⁽¹⁾

PARAMETER	SN74AHCT240			UNIT
	MIN	TYP	MAX	
$V_{OH(V)}$ Quiet output, minimum dynamic V_{OH}		4.1		V
$V_{IH(D)}$ High-level dynamic input voltage	2			V
$V_{IL(D)}$ Low-level dynamic input voltage			0.8	V

(1) Characteristics are for surface-mount packages only.

6.8 Operating Characteristics

$V_{CC} = 5\text{ V}$, $T_A = 25^\circ\text{C}$

PARAMETER	TEST CONDITIONS	TYP	UNIT
C_{pd} Power dissipation capacitance	No load, $f = 1\text{ MHz}$	10	pF

7 Typical Characteristics



图 1. TPD vs Temperature

8 Parameter Measurement Information

Unless otherwise noted, all input pulses are supplied by generators having the following characteristics:

- $PRR \leq 1 \text{ MHz}$
- $Z_O = 50 \Omega$
- $t_r \leq 3 \text{ ns}$
- $t_f \leq 3 \text{ ns}$

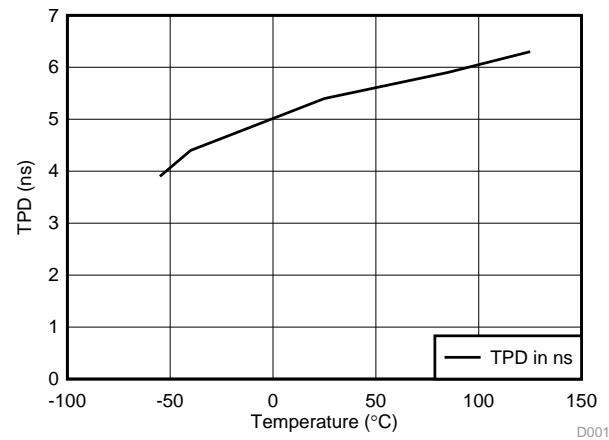
注

All parameters and waveforms are not applicable to all devices.

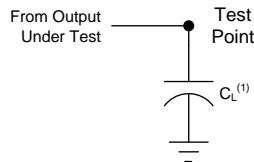

- (1) C_L includes probe and jig capacitance.
- (2) The outputs are measured one at a time, with one transition per measurement.

图 2. Load Circuit For Totem-Pole Outputs

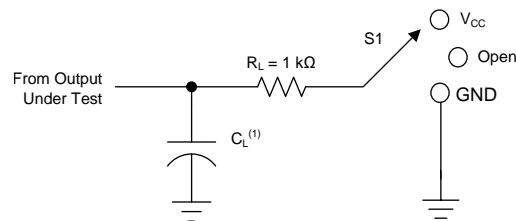

- (1) C_L includes probe and jig capacitance.
- (2) The outputs are measured one at a time, with one transition per measurement.

图 3. Load Circuit For Tri-State And Open-Drain Outputs

表 1. Loading Conditions For Parameter

TEST	S1
$t_{PLH}^{(1)}$, $t_{PHL}^{(1)}$	Open
$t_{PLZ}^{(2)}$, $t_{PZL}^{(3)}$	V_{CC}
$t_{PHZ}^{(2)}$, $t_{PZH}^{(3)}$	GND
Open drain	V_{CC}

- (1) t_{PLH} and t_{PHL} are the same as t_{pd} .
- (2) t_{PLZ} and t_{PHZ} are the same as t_{dis} .
- (3) t_{PZL} and t_{PZH} are the same as t_{en} .



图 4. Voltage Waveforms Pulse Durations



(1) The outputs are measured one at a time, with one transition per measurement.

图 5. Voltage Waveforms Propagation Delay Times Inverting and Noninverting Outputs

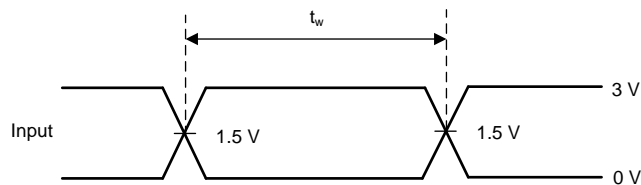
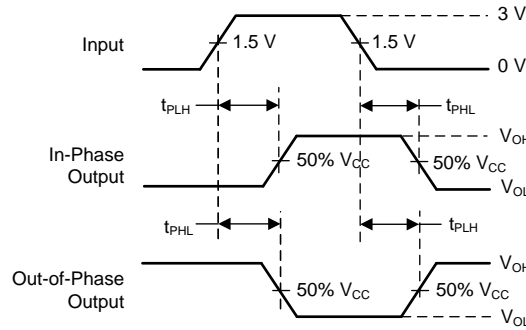

图 6. Voltage Waveforms Setup And Hold Times



- (1) Waveform 1 is for an output with internal conditions such that the output is low, except when disabled by the output control.
- (2) Waveform 2 is for an output with internal conditions such that the output is high, except when disabled by the output control.
- (3) The outputs are measured one at a time, with one transition per measurement.

图 7. Voltage Waveforms Enable And Disable Times Low- and High-Level Enabling

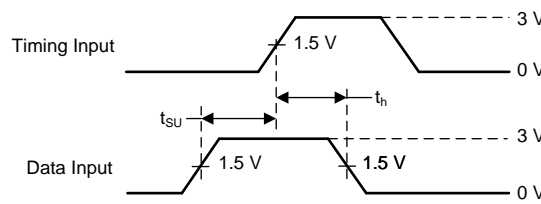
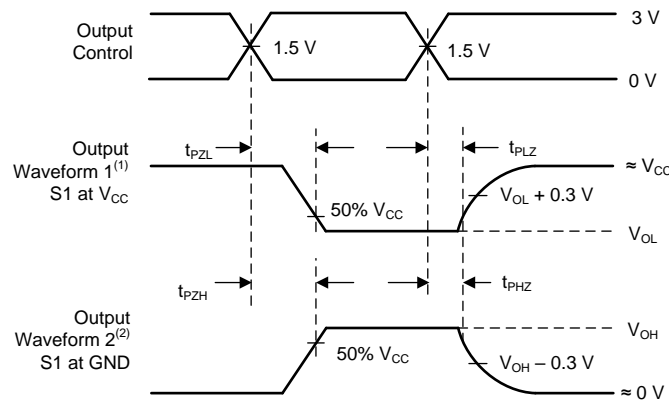
9 Detailed Description

9.1 Overview

The SN74AHCT240 devices are organized as two 4-bit buffers/line drivers with separate output-enable (\overline{OE}) inputs. When \overline{OE} is low, the device passes inverted data from the A inputs to the Y outputs. When \overline{OE} is high, the outputs are in the high-impedance state. To ensure the high-impedance state during power up or power down, \overline{OE} should be tied to V_{CC} through a pull-up resistor; the minimum value of the resistor is determined by the current-sinking capability of the driver.

9.2 Functional Block Diagram

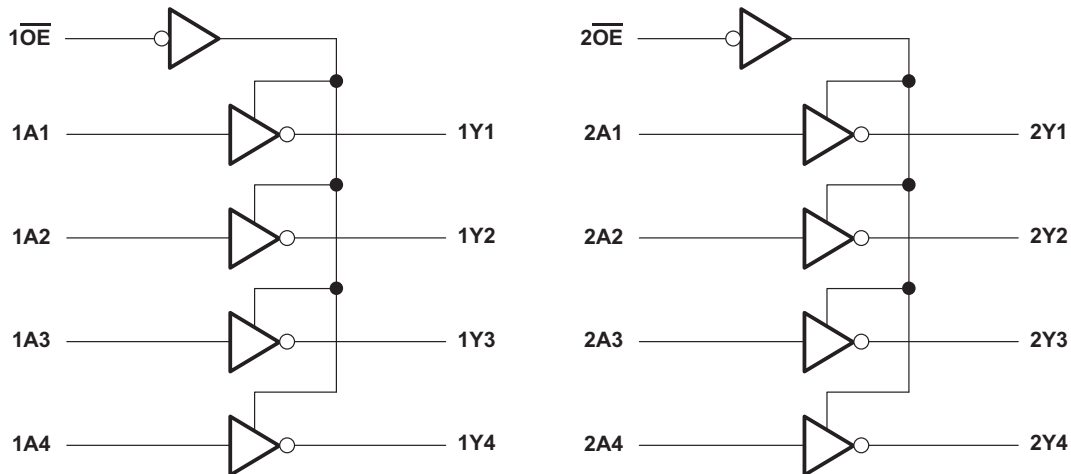

Copyright © 2016, Texas Instruments Incorporated

9.3 Feature Description

- V_{CC} is optimized at 5 V
- Allows up-voltage translation from 3.3 V to 5 V
 - Inputs accept V_{IH} levels of 2 V
- Slow edge rates minimize output ringing
- Inputs are TTL-voltage compatible

9.4 Device Functional Modes

表 2. Function Table
(Each 4-bit Inverting Buffer/Driver)

INPUTS		OUTPUT Y
\overline{OE}	A	
L	H	L
L	L	H
H	X	Z

10 Application and Implementation

注

Information in the following applications sections is not part of the TI component specification, and TI does not warrant its accuracy or completeness. TI's customers are responsible for determining suitability of components for their purposes. Customers should validate and test their design implementation to confirm system functionality.

10.1 Application Information

The SNx4AHCT240 device is a low-drive CMOS device that may be used for a multitude of bus interface type applications where output ringing is a concern. The low drive and slow edge rates will minimize overshoot and undershoot on the outputs. The input switching levels have been lowered to accommodate TTL inputs of 0.8-V V_{IL} and 2-V V_{IH} . This feature makes the SNx4AHCT240 device ideal for translating up from 3.3 V to 5 V. 图 8 shows this type of translation.

10.2 Typical Application

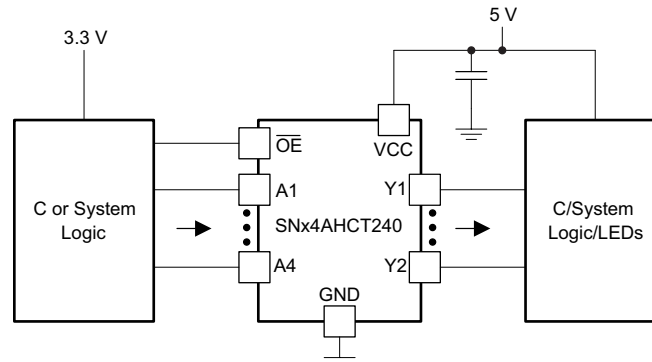

Copyright © 2018, Texas Instruments Incorporated

图 8. Application Diagram

10.2.1 Design Requirements

This device uses CMOS technology and has balanced output drive. Care should be taken to avoid bus contention because it can drive currents that would exceed maximum limits. The high drive will also create fast edges into light loads; therefore, routing and load conditions should be considered to prevent ringing.

10.2.2 Detailed Design Procedure

1. Recommended Input Conditions:
 - For rise time and fall time specifications, see $\Delta t/\Delta V$ in the [Recommended Operating Conditions](#) table.
 - For specified high and low levels, see V_{IH} and V_{IL} in the [Recommended Operating Conditions](#) table.
 - Inputs are overvoltage tolerant, allowing them to go as high as 5.5 V at any valid V_{CC} .
2. Recommend Output Conditions:
 - Load currents should not exceed 25 mA per output and 75 mA total for the part.
 - Outputs should not be pulled above V_{CC} .

Typical Application (接下页)

10.2.3 Application Curves

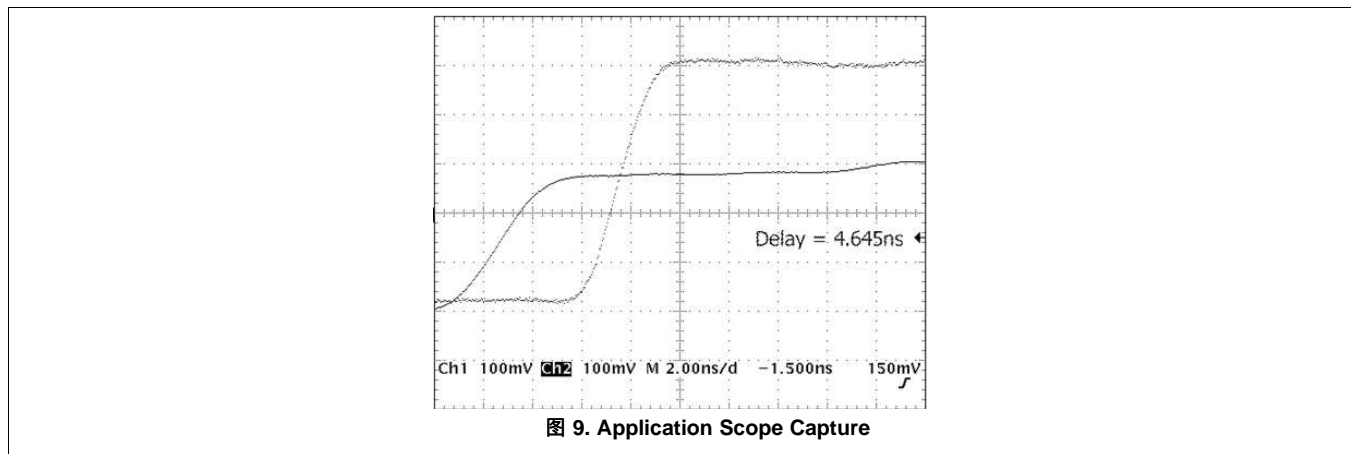

11 Power Supply Recommendations

The power supply can be any voltage between the MIN and MAX supply voltage rating located in the [Recommended Operating Conditions](#).

Each V_{CC} terminal should have a good bypass capacitor to prevent power disturbance. For devices with a single supply, a 0.1 μF capacitor is recommended. If there are multiple V_{CC} terminals then 0.01 μF or 0.022 μF capacitors are recommended for each power terminal. It is ok to parallel multiple bypass capacitors to reject different frequencies of noise. 0.1 μF and 1.0 μF capacitors are commonly used in parallel. The bypass capacitor should be installed as close to the power terminal as possible for the best results.

12 Layout

12.1 Layout Guidelines

When using multiple bit logic devices, inputs should not float. In many cases, functions or parts of functions of digital logic devices are unused. Such examples are when only two inputs of a triple-input AND gate are used, or only 3 of the 4-buffer gates are used. Such input pins should not be left unconnected because the undefined voltages at the outside connections result in undefined operational states.

Specified in [图 10](#) are rules that must be observed under all circumstances. All unused inputs of digital logic devices must be connected to a high or low bias to prevent them from floating. The logic level that should be applied to any particular unused input depends on the function of the device. Generally they will be tied to GND or V_{CC} , whichever makes more sense or is more convenient. It is acceptable to float outputs unless the part is a transceiver. If the transceiver has an output enable pin, it will disable the outputs section of the part when asserted. This will not disable the input section of the I/Os so they also cannot float when disabled.

12.2 Layout Example



图 10. Layout Diagram

13 器件和文档支持

13.1 社区资源

下列链接提供到 TI 社区资源的连接。链接的内容由各个分销商“按照原样”提供。这些内容并不构成 TI 技术规范，并且不一定反映 TI 的观点；请参阅 TI 的《使用条款》。

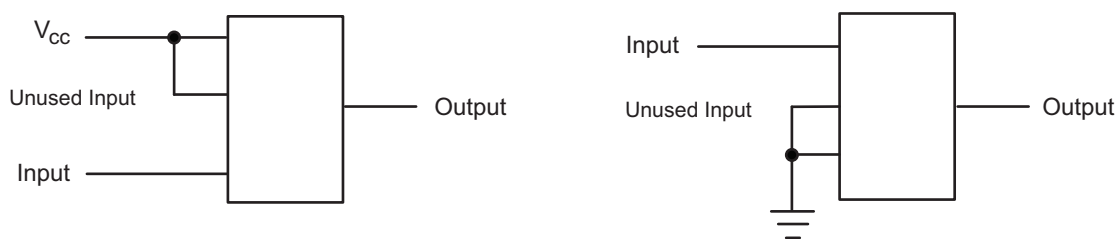
TI E2E™ 在线社区 *TI 的工程师对工程师 (E2E) 社区*。此社区的创建目的在于促进工程师之间的协作。在 e2e.ti.com 中，您可以咨询问题、分享知识、拓展思路并与同行工程师一道帮助解决问题。

设计支持 *TI 参考设计支持* 可帮助您快速查找有帮助的 E2E 论坛、设计支持工具以及技术支持的联系信息。

13.2 相关链接

下表列出了快速访问链接。类别包括技术文档、支持和社区资源、工具和软件以及申请样片或购买产品的快速访问链接。

表 3. 相关链接

器件	产品文件夹	样片与购买	技术文档	工具和软件	支持和社区
SN54AHCT240	请单击此处	请单击此处	请单击此处	请单击此处	请单击此处
SN74AHCT240	请单击此处	请单击此处	请单击此处	请单击此处	请单击此处

13.3 商标

E2E is a trademark of Texas Instruments.
All other trademarks are the property of their respective owners.

13.4 静电放电警告



这些装置包含有限的内置 ESD 保护。存储或装卸时，应将导线一起截短或将装置放置于导电泡棉中，以防止 MOS 门极遭受静电损伤。

13.5 Glossary

[SLYZ022](#) — *TI Glossary*.

This glossary lists and explains terms, acronyms, and definitions.

14 机械、封装和可订购信息

以下页面包含机械、封装和可订购信息。这些信息是指定器件的最新可用数据。数据如有变更，恕不另行通知，也不会对此文档进行修订。如欲获取此数据表的浏览器版本，请参阅左侧的导航。

PACKAGING INFORMATION

Orderable Device	Status (1)	Package Type	Package Drawing	Pins	Package Qty	Eco Plan (2)	Lead finish/ Ball material (6)	MSL Peak Temp (3)	Op Temp (°C)	Device Marking (4/5)	Samples
5962-9680601Q2A	ACTIVE	LCCC	FK	20	1	Non-RoHS & Green	SNPB	N / A for Pkg Type	-55 to 125	5962-9680601Q2A SNJ54AHCT 240FK	Samples
5962-9680601QRA	ACTIVE	CDIP	J	20	1	Non-RoHS & Green	SNPB	N / A for Pkg Type	-55 to 125	5962-9680601QR A SNJ54AHCT240J	Samples
5962-9680601QSA	ACTIVE	CFP	W	20	1	Non-RoHS & Green	SNPB	N / A for Pkg Type	-55 to 125	5962-9680601QS A SNJ54AHCT240W	Samples
SN74AHCT240DBR	ACTIVE	SSOP	DB	20	2000	RoHS & Green	NIPDAU	Level-1-260C-UNLIM	-40 to 125	HB240	Samples
SN74AHCT240DW	ACTIVE	SOIC	DW	20	25	RoHS & Green	NIPDAU	Level-1-260C-UNLIM	-40 to 125	AHCT240	Samples
SN74AHCT240DWR	ACTIVE	SOIC	DW	20	2000	RoHS & Green	NIPDAU	Level-1-260C-UNLIM	-40 to 125	AHCT240	Samples
SN74AHCT240N	ACTIVE	PDIP	N	20	20	RoHS & Non-Green	NIPDAU	N / A for Pkg Type	-40 to 125	SN74AHCT240N	Samples
SN74AHCT240NSR	ACTIVE	SO	NS	20	2000	RoHS & Green	NIPDAU	Level-1-260C-UNLIM	-40 to 125	AHCT240	Samples
SN74AHCT240NSRE4	ACTIVE	SO	NS	20	2000	RoHS & Green	NIPDAU	Level-1-260C-UNLIM	-40 to 125	AHCT240	Samples
SN74AHCT240PW	ACTIVE	TSSOP	PW	20	70	RoHS & Green	NIPDAU	Level-1-260C-UNLIM	-40 to 125	HB240	Samples
SN74AHCT240PWE4	ACTIVE	TSSOP	PW	20	70	RoHS & Green	NIPDAU	Level-1-260C-UNLIM	-40 to 125	HB240	Samples
SN74AHCT240PWG4	ACTIVE	TSSOP	PW	20	70	RoHS & Green	NIPDAU	Level-1-260C-UNLIM	-40 to 125	HB240	Samples
SN74AHCT240PWR	ACTIVE	TSSOP	PW	20	2000	RoHS & Green	NIPDAU	Level-1-260C-UNLIM	-40 to 125	HB240	Samples
SN74AHCT240PWRG4	ACTIVE	TSSOP	PW	20	2000	RoHS & Green	NIPDAU	Level-1-260C-UNLIM	-40 to 125	HB240	Samples
SNJ54AHCT240FK	ACTIVE	LCCC	FK	20	1	Non-RoHS & Green	SNPB	N / A for Pkg Type	-55 to 125	5962-9680601Q2A SNJ54AHCT 240FK	Samples
SNJ54AHCT240J	ACTIVE	CDIP	J	20	1	Non-RoHS & Green	SNPB	N / A for Pkg Type	-55 to 125	5962-9680601QR A	Samples

Orderable Device	Status (1)	Package Type	Package Drawing	Pins	Package Qty	Eco Plan (2)	Lead finish/ Ball material (6)	MSL Peak Temp (3)	Op Temp (°C)	Device Marking (4/5)	Samples
SNJ54AHCT240W	ACTIVE	CFP	W	20	1	Non-RoHS & Green	SNPB	N / A for Pkg Type	-55 to 125	SNJ54AHCT240J 5962-9680601QS A SNJ54AHCT240W	

(1) The marketing status values are defined as follows:

ACTIVE: Product device recommended for new designs.

LIFEBUY: TI has announced that the device will be discontinued, and a lifetime-buy period is in effect.

NRND: Not recommended for new designs. Device is in production to support existing customers, but TI does not recommend using this part in a new design.

PREVIEW: Device has been announced but is not in production. Samples may or may not be available.

OBSELETE: TI has discontinued the production of the device.

(2) **RoHS:** TI defines "RoHS" to mean semiconductor products that are compliant with the current EU RoHS requirements for all 10 RoHS substances, including the requirement that RoHS substance do not exceed 0.1% by weight in homogeneous materials. Where designed to be soldered at high temperatures, "RoHS" products are suitable for use in specified lead-free processes. TI may reference these types of products as "Pb-Free".

RoHS Exempt: TI defines "RoHS Exempt" to mean products that contain lead but are compliant with EU RoHS pursuant to a specific EU RoHS exemption.

Green: TI defines "Green" to mean the content of Chlorine (Cl) and Bromine (Br) based flame retardants meet JS709B low halogen requirements of <=1000ppm threshold. Antimony trioxide based flame retardants must also meet the <=1000ppm threshold requirement.

(3) MSL, Peak Temp. - The Moisture Sensitivity Level rating according to the JEDEC industry standard classifications, and peak solder temperature.

(4) There may be additional marking, which relates to the logo, the lot trace code information, or the environmental category on the device.

(5) Multiple Device Markings will be inside parentheses. Only one Device Marking contained in parentheses and separated by a "~" will appear on a device. If a line is indented then it is a continuation of the previous line and the two combined represent the entire Device Marking for that device.

(6) Lead finish/Ball material - Orderable Devices may have multiple material finish options. Finish options are separated by a vertical ruled line. Lead finish/Ball material values may wrap to two lines if the finish value exceeds the maximum column width.

Important Information and Disclaimer:The information provided on this page represents TI's knowledge and belief as of the date that it is provided. TI bases its knowledge and belief on information provided by third parties, and makes no representation or warranty as to the accuracy of such information. Efforts are underway to better integrate information from third parties. TI has taken and continues to take reasonable steps to provide representative and accurate information but may not have conducted destructive testing or chemical analysis on incoming materials and chemicals. TI and TI suppliers consider certain information to be proprietary, and thus CAS numbers and other limited information may not be available for release.

In no event shall TI's liability arising out of such information exceed the total purchase price of the TI part(s) at issue in this document sold by TI to Customer on an annual basis.

OTHER QUALIFIED VERSIONS OF SN54AHCT240, SN74AHCT240 :

- Catalog : [SN74AHCT240](#)
- Automotive : [SN74AHCT240-Q1](#), [SN74AHCT240-Q1](#)
- Military : [SN54AHCT240](#)

NOTE: Qualified Version Definitions:

- Catalog - TI's standard catalog product
- Automotive - Q100 devices qualified for high-reliability automotive applications targeting zero defects
- Military - QML certified for Military and Defense Applications

TAPE AND REEL INFORMATION

QUADRANT ASSIGNMENTS FOR PIN 1 ORIENTATION IN TAPE

*All dimensions are nominal

Device	Package Type	Package Drawing	Pins	SPQ	Reel Diameter (mm)	Reel Width W1 (mm)	A0 (mm)	B0 (mm)	K0 (mm)	P1 (mm)	W (mm)	Pin1 Quadrant
SN74AHCT240DBR	SSOP	DB	20	2000	330.0	16.4	8.2	7.5	2.5	12.0	16.0	Q1
SN74AHCT240DWR	SOIC	DW	20	2000	330.0	24.4	10.8	13.3	2.7	12.0	24.0	Q1
SN74AHCT240NSR	SO	NS	20	2000	330.0	24.4	8.4	13.0	2.5	12.0	24.0	Q1
SN74AHCT240PWR	TSSOP	PW	20	2000	330.0	16.4	6.95	7.0	1.4	8.0	16.0	Q1

TAPE AND REEL BOX DIMENSIONS

*All dimensions are nominal

Device	Package Type	Package Drawing	Pins	SPQ	Length (mm)	Width (mm)	Height (mm)
SN74AHCT240DBR	SSOP	DB	20	2000	853.0	449.0	35.0
SN74AHCT240DWR	SOIC	DW	20	2000	367.0	367.0	45.0
SN74AHCT240NSR	SO	NS	20	2000	367.0	367.0	45.0
SN74AHCT240PWR	TSSOP	PW	20	2000	853.0	449.0	35.0

TUBE

*All dimensions are nominal

Device	Package Name	Package Type	Pins	SPQ	L (mm)	W (mm)	T (μm)	B (mm)
5962-9680601Q2A	FK	LCCC	20	1	506.98	12.06	2030	NA
SN74AHCT240DW	DW	SOIC	20	25	507	12.83	5080	6.6
SN74AHCT240N	N	PDIP	20	20	506	13.97	11230	4.32
SN74AHCT240PW	PW	TSSOP	20	70	530	10.2	3600	3.5
SN74AHCT240PWE4	PW	TSSOP	20	70	530	10.2	3600	3.5
SN74AHCT240PWG4	PW	TSSOP	20	70	530	10.2	3600	3.5
SNJ54AHCT240FK	FK	LCCC	20	1	506.98	12.06	2030	NA

W (R-GDFP-F20)

CERAMIC DUAL FLATPACK

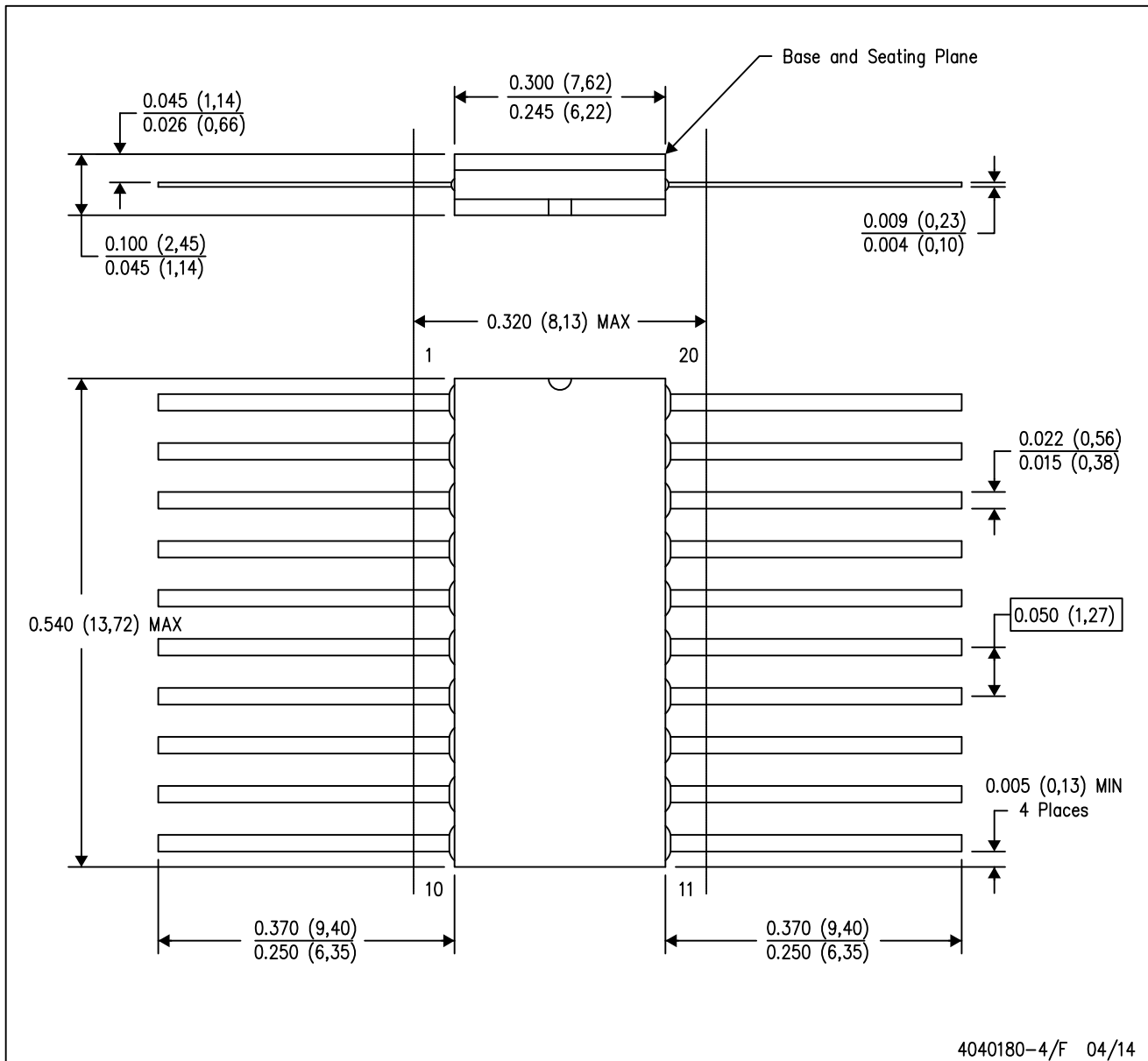

- NOTES:
- A. All linear dimensions are in inches (millimeters).
 - B. This drawing is subject to change without notice.
 - C. This package can be hermetically sealed with a ceramic lid using glass frit.
 - D. Index point is provided on cap for terminal identification only.
 - E. Falls within Mil-Std 1835 GDFP2-F20

PW0020A



PACKAGE OUTLINE

TSSOP - 1.2 mm max height

SMALL OUTLINE PACKAGE



4220206/A 02/2017

NOTES:

1. All linear dimensions are in millimeters. Any dimensions in parenthesis are for reference only. Dimensioning and tolerancing per ASME Y14.5M.
2. This drawing is subject to change without notice.
3. This dimension does not include mold flash, protrusions, or gate burrs. Mold flash, protrusions, or gate burrs shall not exceed 0.15 mm per side.
4. This dimension does not include interlead flash. Interlead flash shall not exceed 0.25 mm per side.
5. Reference JEDEC registration MO-153.

EXAMPLE BOARD LAYOUT

PW0020A

TSSOP - 1.2 mm max height

SMALL OUTLINE PACKAGE



LAND PATTERN EXAMPLE
EXPOSED METAL SHOWN
SCALE: 10X



SOLDER MASK DETAILS

4220206/A 02/2017

NOTES: (continued)

- 6. Publication IPC-7351 may have alternate designs.
- 7. Solder mask tolerances between and around signal pads can vary based on board fabrication site.

EXAMPLE STENCIL DESIGN

PW0020A

TSSOP - 1.2 mm max height

SMALL OUTLINE PACKAGE



SOLDER PASTE EXAMPLE
BASED ON 0.125 mm THICK STENCIL
SCALE: 10X

4220206/A 02/2017

NOTES: (continued)

8. Laser cutting apertures with trapezoidal walls and rounded corners may offer better paste release. IPC-7525 may have alternate design recommendations.
9. Board assembly site may have different recommendations for stencil design.

PW (R-PDSO-G20)

PLASTIC SMALL OUTLINE



- NOTES:
- A. All linear dimensions are in millimeters.
 - B. This drawing is subject to change without notice.
 - C. Publication IPC-7351 is recommended for alternate design.
 - D. Laser cutting apertures with trapezoidal walls and also rounding corners will offer better paste release. Customers should contact their board assembly site for stencil design recommendations. Refer to IPC-7525 for other stencil recommendations.
 - E. Customers should contact their board fabrication site for solder mask tolerances between and around signal pads.

FK (S-CQCC-N**)

LEADLESS CERAMIC CHIP CARRIER

28 TERMINAL SHOWN

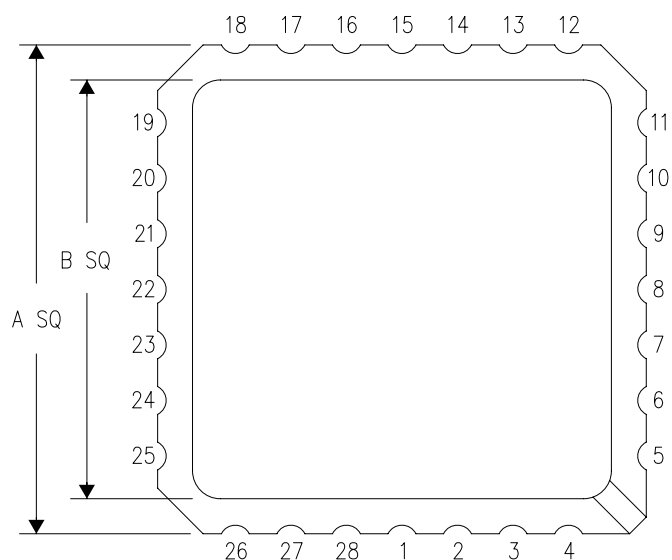

NO. OF TERMINALS **	A		B	
	MIN	MAX	MIN	MAX
20	0.342 (8,69)	0.358 (9,09)	0.307 (7,80)	0.358 (9,09)
28	0.442 (11,23)	0.458 (11,63)	0.406 (10,31)	0.458 (11,63)
44	0.640 (16,26)	0.660 (16,76)	0.495 (12,58)	0.560 (14,22)
52	0.740 (18,78)	0.761 (19,32)	0.495 (12,58)	0.560 (14,22)
68	0.938 (23,83)	0.962 (24,43)	0.850 (21,6)	0.858 (21,8)
84	1.141 (28,99)	1.165 (29,59)	1.047 (26,6)	1.063 (27,0)

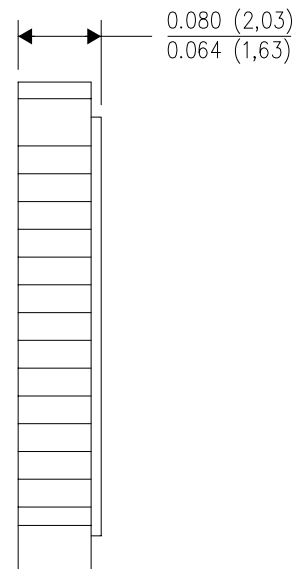
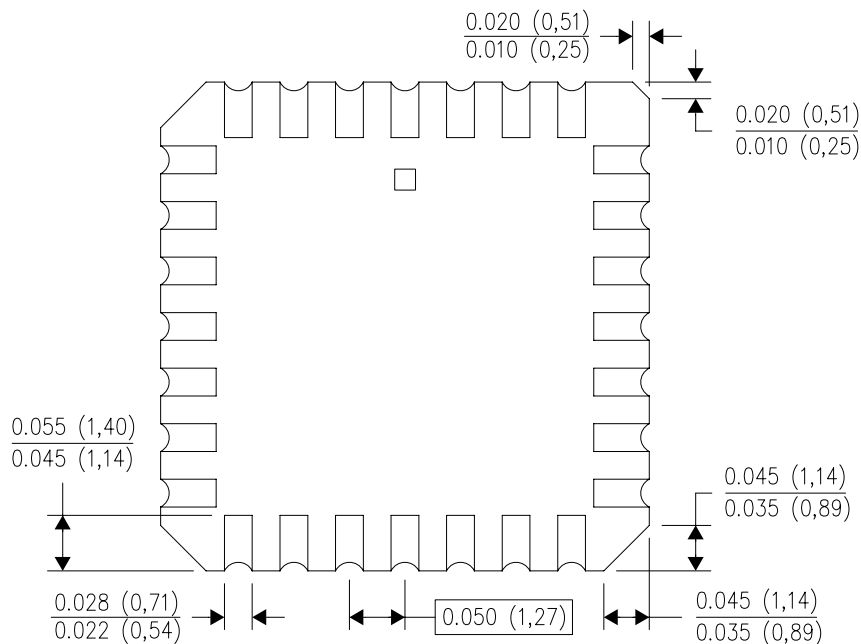

4040140/D 01/11

- NOTES:
- All linear dimensions are in inches (millimeters).
 - This drawing is subject to change without notice.
 - This package can be hermetically sealed with a metal lid.
 - Falls within JEDEC MS-004

DB0020A



PACKAGE OUTLINE

SSOP - 2 mm max height

SMALL OUTLINE PACKAGE



4214851/B 08/2019

NOTES:

1. All linear dimensions are in millimeters. Any dimensions in parenthesis are for reference only. Dimensioning and tolerancing per ASME Y14.5M.
2. This drawing is subject to change without notice.
3. This dimension does not include mold flash, protrusions, or gate burrs. Mold flash, protrusions, or gate burrs shall not exceed 0.15 mm per side.
4. This dimension does not include interlead flash. Interlead flash shall not exceed 0.25 mm per side.
5. Reference JEDEC registration MO-150.

EXAMPLE BOARD LAYOUT

DB0020A

SSOP - 2 mm max height

SMALL OUTLINE PACKAGE



LAND PATTERN EXAMPLE
EXPOSED METAL SHOWN
SCALE: 10X



4214851/B 08/2019

NOTES: (continued)

- 6. Publication IPC-7351 may have alternate designs.
- 7. Solder mask tolerances between and around signal pads can vary based on board fabrication site.

EXAMPLE STENCIL DESIGN

DB0020A

SSOP - 2 mm max height

SMALL OUTLINE PACKAGE



SOLDER PASTE EXAMPLE
BASED ON 0.125 mm THICK STENCIL
SCALE: 10X

4214851/B 08/2019

NOTES: (continued)

8. Laser cutting apertures with trapezoidal walls and rounded corners may offer better paste release. IPC-7525 may have alternate design recommendations.
9. Board assembly site may have different recommendations for stencil design.

MECHANICAL DATA

NS (R-PDSO-G**)

PLASTIC SMALL-OUTLINE PACKAGE

14-PINS SHOWN



- NOTES:
- A. All linear dimensions are in millimeters.
 - B. This drawing is subject to change without notice.
 - C. Body dimensions do not include mold flash or protrusion, not to exceed 0,15.

J (R-GDIP-T**)

14 LEADS SHOWN

CERAMIC DUAL IN-LINE PACKAGE

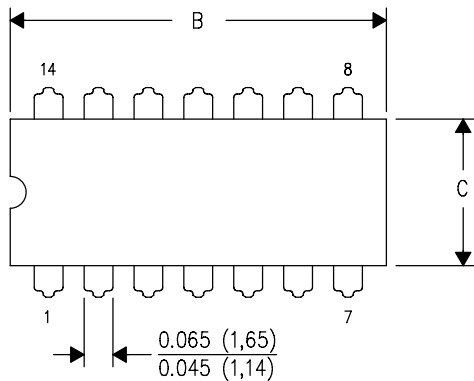

DIM \ PINS **	14	16	18	20
A	0.300 (7,62) BSC	0.300 (7,62) BSC	0.300 (7,62) BSC	0.300 (7,62) BSC
B MAX	0.785 (19,94)	.840 (21,34)	0.960 (24,38)	1.060 (26,92)
B MIN	—	—	—	—
C MAX	0.300 (7,62)	0.300 (7,62)	0.310 (7,87)	0.300 (7,62)
C MIN	0.245 (6,22)	0.245 (6,22)	0.220 (5,59)	0.245 (6,22)



4040083/F 03/03

- NOTES:
- All linear dimensions are in inches (millimeters).
 - This drawing is subject to change without notice.
 - This package is hermetically sealed with a ceramic lid using glass frit.
 - Index point is provided on cap for terminal identification only on press ceramic glass frit seal only.
 - Falls within MIL STD 1835 GDIP1-T14, GDIP1-T16, GDIP1-T18 and GDIP1-T20.

N (R-PDIP-T**)

PLASTIC DUAL-IN-LINE PACKAGE

16 PINS SHOWN



- NOTES:
- A. All linear dimensions are in inches (millimeters).
 - B. This drawing is subject to change without notice.
 - C Falls within JEDEC MS-001, except 18 and 20 pin minimum body length (Dim A).
 - D The 20 pin end lead shoulder width is a vendor option, either half or full width.

4040049/E 12/2002

DW0020A



PACKAGE OUTLINE

SOIC - 2.65 mm max height

SOIC

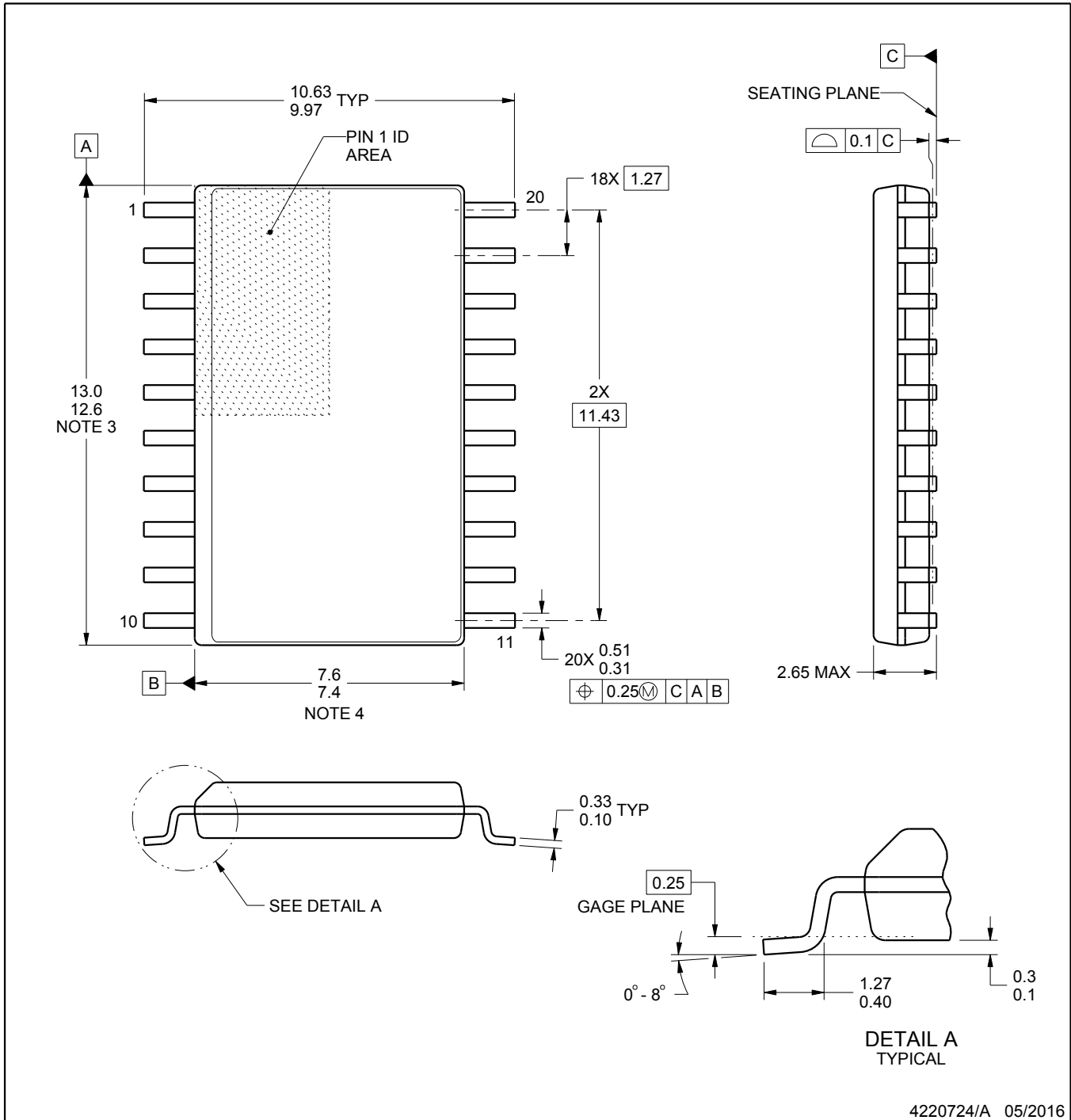

4220724/A 05/2016

NOTES:

1. All linear dimensions are in millimeters. Dimensions in parenthesis are for reference only. Dimensioning and tolerancing per ASME Y14.5M.
2. This drawing is subject to change without notice.
3. This dimension does not include mold flash, protrusions, or gate burrs. Mold flash, protrusions, or gate burrs shall not exceed 0.15 mm per side.
4. This dimension does not include interlead flash. Interlead flash shall not exceed 0.43 mm per side.
5. Reference JEDEC registration MS-013.

EXAMPLE BOARD LAYOUT

DW0020A

SOIC - 2.65 mm max height

SOIC



LAND PATTERN EXAMPLE
SCALE:6X



SOLDER MASK DETAILS

4220724/A 05/2016

NOTES: (continued)

- 6. Publication IPC-7351 may have alternate designs.
- 7. Solder mask tolerances between and around signal pads can vary based on board fabrication site.

EXAMPLE STENCIL DESIGN

DW0020A

SOIC - 2.65 mm max height

SOIC

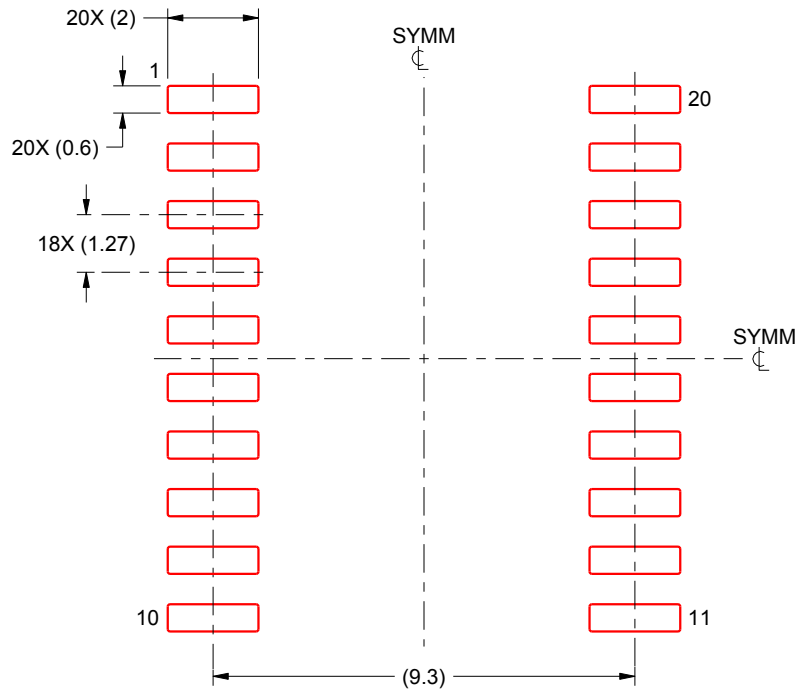

SOLDER PASTE EXAMPLE
BASED ON 0.125 mm THICK STENCIL
SCALE:6X

4220724/A 05/2016

NOTES: (continued)

8. Laser cutting apertures with trapezoidal walls and rounded corners may offer better paste release. IPC-7525 may have alternate design recommendations.
9. Board assembly site may have different recommendations for stencil design.

重要声明和免责声明

TI“按原样”提供技术和可靠性数据（包括数据表）、设计资源（包括参考设计）、应用或其他设计建议、网络工具、安全信息和其他资源，不保证没有瑕疵且不做任何明示或暗示的担保，包括但不限于对适销性、某特定用途方面的适用性或不侵犯任何第三方知识产权的暗示担保。

这些资源可供使用 TI 产品进行设计的熟练开发人员使用。您将自行承担以下全部责任：(1) 针对您的应用选择合适的 TI 产品，(2) 设计、验证并测试您的应用，(3) 确保您的应用满足相应标准以及任何其他功能安全、信息安全、监管或其他要求。

这些资源如有变更，恕不另行通知。TI 授权您仅可将这些资源用于研发本资源所述的 TI 产品的应用。严禁对这些资源进行其他复制或展示。您无权使用任何其他 TI 知识产权或任何第三方知识产权。您应全额赔偿因在这些资源的使用中对 TI 及其代表造成的任何索赔、损害、成本、损失和债务，TI 对此概不负责。

TI 提供的产品受 [TI 的销售条款](#) 或 [ti.com](#) 上其他适用条款/TI 产品随附的其他适用条款的约束。TI 提供这些资源并不会扩展或以其他方式更改 TI 针对 TI 产品发布的适用的担保或担保免责声明。

TI 反对并拒绝您可能提出的任何其他或不同的条款。

邮寄地址：Texas Instruments, Post Office Box 655303, Dallas, Texas 75265

Copyright © 2022，德州仪器 (TI) 公司