



# 800mA and 1A Low Dropout Positive Regulator

## 1.8V, 2.5V, 2.85, 3.3V, 5V, and Adjustable

### FEATURES

- **FIXED AND ADJUSTABLE VERSIONS**
- **2.85V MODEL FOR SCSI-2 ACTIVE TERMINATION**
- **OUTPUT CURRENT:**  
REG1117: 800mA max  
REG117A: 1A max
- **OUTPUT TOLERANCE:  $\pm 1\%$  max**
- **DROPOUT VOLTAGE:**  
REG1117: 1.2V max at  $I_O = 800\text{mA}$   
REG117A: 1.3V max at  $I_O = 1\text{A}$
- **INTERNAL CURRENT LIMIT**
- **THERMAL OVERLOAD PROTECTION**
- **SOT-223 AND DDPAK SURFACE-MOUNT PACKAGES**

### APPLICATIONS

- **SCSI-2 ACTIVE TERMINATION**
- **HAND-HELD DATA COLLECTION DEVICES**
- **HIGH EFFICIENCY LINEAR REGULATORS**
- **BATTERY-POWERED INSTRUMENTATION**
- **BATTERY MANAGEMENT CIRCUITS FOR NOTEBOOK AND PALMTOP PCs**
- **CORE VOLTAGE SUPPLY: FPGA, PLD, DSP, CPU**

### DESCRIPTION

The REG1117 is a family of easy-to-use three-terminal voltage regulators. The family includes a variety of fixed- and adjustable-voltage versions, two currents (800mA and 1A) and two package types (SOT-223 and DDPAK). See the chart below for available options.

Output voltage of the adjustable versions is set with two external resistors. The REG1117 low dropout voltage allows its use with as little as 1V input-output voltage differential.

Laser trimming assures excellent output voltage accuracy without adjustment. An NPN output stage allows output stage drive to contribute to the load current for maximum efficiency.

VOLTAGE	800mA		1A	
	SOT-223	DDPAK	SOT-223	DDPAK
1.8V			✓	✓
2.5V			✓	✓
2.85V	✓			
3.3V	✓	✓		
5V	✓			✓
Adjustable	✓		✓	✓



Please be aware that an important notice concerning availability, standard warranty, and use in critical applications of Texas Instruments semiconductor products and disclaimers thereto appears at the end of this data sheet.

All trademarks are the property of their respective owners.

**ABSOLUTE MAXIMUM RATINGS(1)**

Power Dissipation . . . . .	Internally Limited
Input Voltage . . . . .	+15V
Operating Junction Temperature Range . . . . .	-40°C to +125°C
Storage Temperature Range . . . . .	-65°C to +150°C
Lead Temperature (soldering, 10s)(2) . . . . .	+300°C

- (1) Stresses above these ratings may cause permanent damage.
- (2) See *Soldering Methods* section.



This integrated circuit can be damaged by ESD. Texas Instruments recommends that all integrated circuits be handled with appropriate precautions. Failure to observe proper handling and installation procedures can cause damage.

ESD damage can range from subtle performance degradation to complete device failure. Precision integrated circuits may be more susceptible to damage because very small parametric changes could cause the device not to meet its published specifications.

**CONNECTION DIAGRAM**

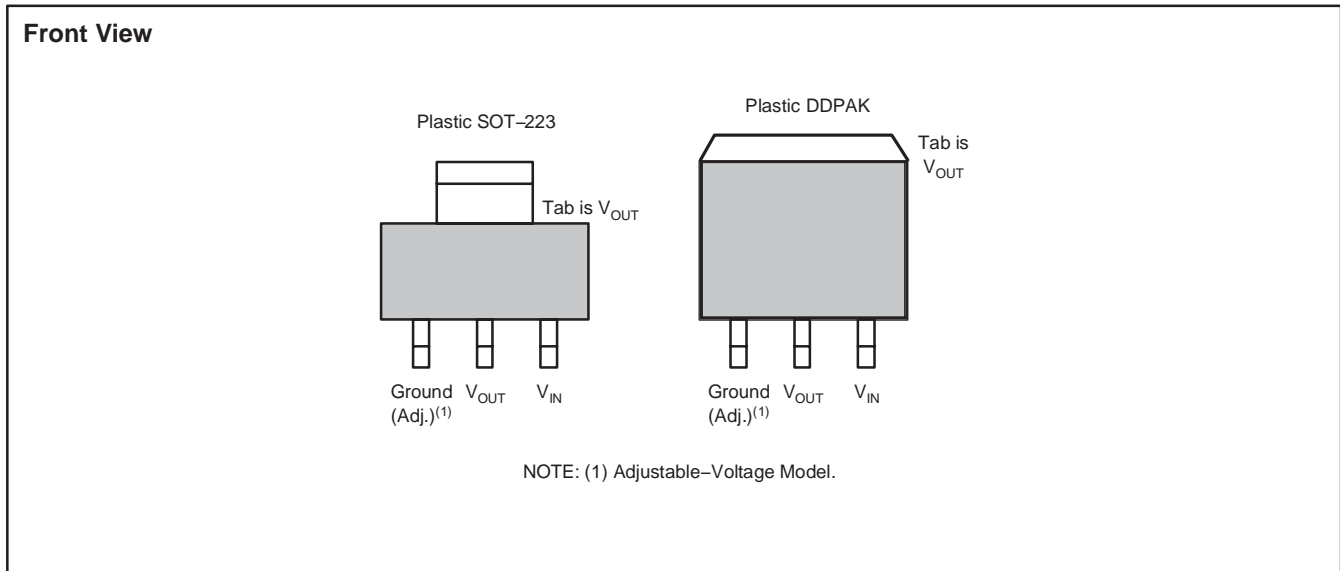

**PACKAGE/ORDERING INFORMATION(1)**

PRODUCT	$V_O/I_O$	PACKAGE-LEAD	PACKAGE DESIGNATOR	OPERATING TEMPERATURE RANGE	PACKAGE MARKING	ORDERING NUMBER	TRANSPORT MEDIA, QUANTITY
REG1117-2.85	2.85/800mA	SOT223-3	DCY	-40°C to +125°C	BB11172	REG1117-2.85	Rails, 80
						REG1117-2.85	Tape and Reel, 2500
REG1117-3.3	3.3/800mA	SOT223-3	DCY	-40°C to +125°C	BB11174	REG1117-3.3	Rails, 80
						REG1117-3.3	Tape and Reel, 2500
REG1117F-3.3	3.3/800mA	DDPAK-3	KTT	-40°C to +125°C	BB1117F4	REG1117F-3.3KTTT	Tape and Reel, 50
						REG1117F-3.3/500	Tape and Reel, 500
REG1117-5	5V/800mA	SOT223-3	DCY	-40°C to +125°C	BB11175	REG1117-5	Rails, 80
						REG1117-5	Tape and Reel, 2500
REG1117	Adj./800mA	SOT223-3	DCY	-40°C to +125°C	BB1117	REG1117	Rails, 80
						REG1117	Tape and Reel, 2500
REG1117A-1.8	1.8V/1A	SOT223-3	DCY	-40°C to +125°C	R111718	REG1117A-1.8	Rails, 80
						REG1117A-1.8	Tape and Reel, 2500
REG1117FA-1.8	1.8/1A	DDPAK-3	KTT	-40°C to +125°C	REG1117FA1.8	REG1117FA-1.8KTTT	Tape and Reel, 50
						REG1117FA-1.8/500	Tape and Reel, 500
REG1117A-2.5	2.5/1A	SOT223-3	DCY	-40°C to +125°C	R111725	REG1117A-2.5	Rails, 80
						REG1117A-2.5	Tape and Reel, 2500
REG1117FA-2.5	2.5/1A	DDPAK-3	KTT	-40°C to +125°C	REG1117FA2.5	REG1117FA-2.5KTTT	Tape and Reel, 50
						REG1117FA-2.5/500	Tape and Reel, 500
REG1117FA-5	5/1A	DDPAK-3	KTT	-40°C to +125°C	BB1117FA5.0	REG1117FA-5/KTTT	Tape and Reel, 50
						REG1117FA-5/500	Tape and Reel, 500
REG1117A	Adj./1A	SOT223-3	DCY	-40°C to +125°C	BB1117A	REG1117A	Rails, 80
						REG1117A	Tape and Reel, 2500
REG1117FA	Adj./1A	DDPAK-3	KTT	-40°C to +125°C	REG1117FA	REG1117FA/KTTT	Tape and Reel, 50
						REG1117FA/500	Tape and Reel, 500

(1) For the most current package and ordering information, see the Package Option Addendum located at the end of this data sheet.

**ELECTRICAL CHARACTERISTICS**

At  $T_J = +25^\circ\text{C}$ , unless otherwise noted.

PARAMETER	CONDITION	REG1117, REG1117A			UNIT
		MIN	TYP	MAX	
<b>OUTPUT VOLTAGE</b>					
REG1117-2.85	$I_O = 10\text{mA}, V_{IN} = 4.85\text{V}$	2.820	2.85	2.880	V
See Note 1	$I_O = 0 \text{ to } 800\text{mA}, V_{IN} = 4.05\text{V to } 10\text{V}$	2.790	2.85	2.910	V
REG1117-3.3	$I_O = 10\text{mA}, V_{IN} = 5.3\text{V}$	3.270	3.30	3.330	V
See Note 1	$I_O = 0 \text{ to } 800\text{mA}, V_{IN} = 4.8\text{V to } 10\text{V}$	3.240	3.30	3.360	V
REG1117-5	$I_O = 10\text{mA}, V_{IN} = 7\text{V}$	4.950	5.00	5.050	V
See Note 1	$I_O = 0 \text{ to } 800\text{mA}, V_{IN} = 6.5\text{V to } 10\text{V}$	4.900	5.00	5.100	V
REG1117A-1.8	$I_O = 10\text{mA}, V_{IN} = 3.8\text{V}$	1.782	1.8	1.818	V
See Note 1	$I_O = 0 \text{ to } 1\text{A}, V_{IN} = 3.8\text{V to } 10\text{V}$	1.764	1.8	1.836	V
REG1117A-2.5	$I_O = 10\text{mA}, V_{IN} = 4.5\text{V}$	2.475	2.5	2.525	V
See Note 1	$I_O = 0 \text{ to } 1\text{A}, V_{IN} = 4.5\text{V to } 10\text{V}$	2.450	2.5	2.550	V
REG1117A-5	$I_O = 10\text{mA}, V_{IN} = 7\text{V}$	4.950	5.0	5.050	V
See Note 1	$I_O = 0 \text{ to } 1\text{A}, V_{IN} = 7\text{V to } 10\text{V}$	4.900	5.0	5.100	V
<b>REFERENCE VOLTAGE</b>					
REG1117 (Adjustable)	$I_O = 10\text{mA}, V_{IN} - V_O = 2\text{V}$	1.238	1.250	1.262	V
See Note 1	$I_O = 10 \text{ to } 800\text{mA}, V_{IN} - V_O = 1.4 \text{ to } 10\text{V}$	1.225	1.250	1.280	V
REG1117A (Adjustable)	$I_O = 10\text{mA}, V_{IN} - V_O = 2\text{V}$	1.238	1.250	1.262	V
See Note 1	$I_O = 10\text{mA to } 1\text{A}, V_{IN} - V_O = 1.4 \text{ to } 10\text{V}$	1.225	1.250	1.280	V
<b>LINE REGULATION</b>					
REG1117-2.85 <sup>(1)</sup>	$I_O = 0, V_{IN} = 4.25 \text{ to } 10\text{V}$		1	7	mV
REG1117-3.3 <sup>(1)</sup>	$I_O = 0, V_{IN} = 4.8 \text{ to } 10\text{V}$		2	7	mV
REG1117-5 <sup>(1)</sup>	$I_O = 0, V_{IN} = 6.5 \text{ to } 15\text{V}$		3	10	mV
REG1117 (Adjustable) <sup>(1)</sup>	$I_O = 10\text{mA}, V_{IN} - V_O = 1.5 \text{ to } 13.75\text{V}$		0.1	0.4	%
REG1117A (Adjustable) <sup>(1)</sup>	$I_O = 10\text{mA}, V_{IN} - V_O = 1.5 \text{ to } 13.75\text{V}$		0.1	0.4	%
REG1117A-1.8 <sup>(1)</sup>	$I_O = 0, V_{IN} = 3.8\text{V to } 10\text{V}$		1	7	mV
REG1117A-2.5 <sup>(1)</sup>	$I_O = 0, V_{IN} = 4.5\text{V to } 10\text{V}$		1	7	mV
REG1117A-5.0 <sup>(1)</sup>	$I_O = 0, V_{IN} = 7\text{V to } 15\text{V}$		3	10	mV
<b>LOAD REGULATION</b>					
REG1117-2.85 <sup>(1)</sup>	$I_O = 0 \text{ to } 800\text{mA}, V_{IN} = 4.25\text{V}$		2	10	mV
REG1117-3.3 <sup>(1)</sup>	$I_O = 0 \text{ to } 800\text{mA}, V_{IN} = 4.8\text{V}$		3	12	mV
REG1117-5 <sup>(1)</sup>	$I_O = 0 \text{ to } 800\text{mA}, V_{IN} = 6.5\text{V}$		3	15	mV
REG1117 (Adjustable) <sup>(1)(2)</sup>	$I_O = 10 \text{ to } 800\text{mA}, V_{IN} - V_O = 3\text{V}$		0.1	0.4	%
REG1117A (Adjustable) <sup>(1)(2)</sup>	$I_O = 10\text{mA to } 1\text{A}, V_{IN} - V_O = 3\text{V}$		0.1	0.4	%
REG1117A-1.8 <sup>(1)</sup>	$I_O = 0 \text{ to } 1\text{A}, V_{IN} = 3.8\text{V}$		2	10	mV
REG1117A-2.5	$I_O = 0 \text{ to } 1\text{A}, V_{IN} = 4.5\text{V}$		2	10	mV
REG1117A-5	$I_O = 0 \text{ to } 1\text{A}, V_{IN} = 7.0\text{V}$		3	15	mV
<b>DROPOUT VOLTAGE<sup>(3)</sup></b>					
All Models <sup>(1)</sup>	$I_O = 100\text{mA}$		1.00	1.10	V
See Note 1	$I_O = 500\text{mA}$		1.05	1.15	V
REG1117 Models <sup>(1)</sup>	$I_O = 800\text{mA}$		1.10	1.20	V
REG1117A	$I_O = 1\text{A}$		1.2	1.30	V
See Note 1	$I_O = 1\text{A}$		1.2	1.55	V

(1) Specification applies over the full specified junction temperature range,  $0^\circ\text{C}$  to  $+125^\circ\text{C}$ .

(2) REG1117 and REG1117A adjustable versions require a minimum load current for  $\pm 3\%$  regulation.

(3) Dropout voltage is the input voltage minus output voltage that produces a 1% decrease in output voltage.

(4) Percentage change in unloaded output voltage before versus after a 30ms power pulse of  $I_O = 800\text{mA}$  (REG1117 models),  $I_O = 1\text{A}$  (REG1117A),  $V_{IN} - V_O = 1.4\text{V}$  (reading taken 10ms after pulse).

**ELECTRICAL CHARACTERISTICS (continued)**

 At  $T_J = +25^\circ\text{C}$ , unless otherwise noted.

PARAMETER	CONDITION	REG1117, REG1117A			UNIT
		MIN	TYP	MAX	
<b>CURRENT LIMIT</b>					
REG1117 Models	$V_{IN} - V_O = 5V$	800	950	1200	mA
REG1117A	$V_{IN} - V_O = 5V$	1000	1250	1600	mA
<b>MINIMUM LOAD CURRENT</b>					
Adjustable Models <sup>(1)(2)</sup>	$V_{IN} - V_O = 13.75V$		1.7	5	mA
<b>QUIESCENT CURRENT</b>					
Fixed-Voltage Models <sup>(1)</sup>	$V_{IN} - V_O = 5V$		4	10	mA
<b>ADJUSTABLE PIN CURRENT<sup>(1)(2)</sup></b>					
vs Load Current, REG1117 <sup>(1)</sup>	$I_O = 10\text{mA}$ , $V_{IN} - V_O = 1.4$ to $10V$		50	120	$\mu\text{A}$
vs Load Current, REG1117A <sup>(1)</sup>	$I_O = 10\text{mA}$ to $800\text{mA}$ , $V_{IN} - V_O = 1.4$ to $10V$		0.5	5	$\mu\text{A}$
	$I_O = 10\text{mA}$ to $1A$ , $V_{IN} - V_O = 1.4$ to $10V$		0.5	5	$\mu\text{A}$
<b>THERMAL REGULATION</b>					
All Models <sup>(4)</sup>	30ms Pulse		0.01	0.1	%/W
<b>RIPPLE REJECTION</b>					
All Models	$f = 120\text{Hz}$ , $V_{IN} - V_{OUT} = 3V + 1V_{PP}$ Ripple		62		dB
<b>TEMPERATURE DRIFT</b>					
Fixed-Voltage Models	$T_J = 0^\circ\text{C}$ to $+125^\circ\text{C}$		0.5		%
Adjustable Models	$T_J = 0^\circ\text{C}$ to $+125^\circ\text{C}$		2		%
<b>LONG-TERM STABILITY</b>					
All Models	$T_A = 125^\circ\text{C}$ , 1000Hr		0.3		%
<b>OUTPUT NOISE</b>					
rms Noise, All Models	$f = 10\text{Hz}$ to $10\text{kHz}$		0.003		%
<b>THERMAL RESISTANCE</b>					
Thermal Resistance, $\theta_{JC}$	(Junction-to-Case at Tab)				
3-Lead SOT-223 Surface-Mount			15		$^\circ\text{C}/\text{W}$
3-Lead DDPAK Surface-Mount	$f > 50\text{Hz}$		2		$^\circ\text{C}/\text{W}$
	dc		3		$^\circ\text{C}/\text{W}$
Thermal Resistance, $\theta_{JA}$	(Junction-to-Case at Tab)				
3-Lead DDPAK Surface-Mount	No Heatsink		65		$^\circ\text{C}/\text{W}$

 (1) Specification applies over the full specified junction temperature range,  $0^\circ\text{C}$  to  $+125^\circ\text{C}$ .

 (2) REG1117 and REG1117A adjustable versions require a minimum load current for  $\pm 3\%$  regulation.

(3) Dropout voltage is the input voltage minus output voltage that produces a 1% decrease in output voltage.

 (4) Percentage change in unloaded output voltage before versus after a 30ms power pulse of  $I_O = 800\text{mA}$  (REG1117 models),  $I_O = 1A$  (REG1117A),  $V_{IN} - V_O = 1.4V$  (reading taken 10ms after pulse).

**SIMPLIFIED SCHEMATIC**

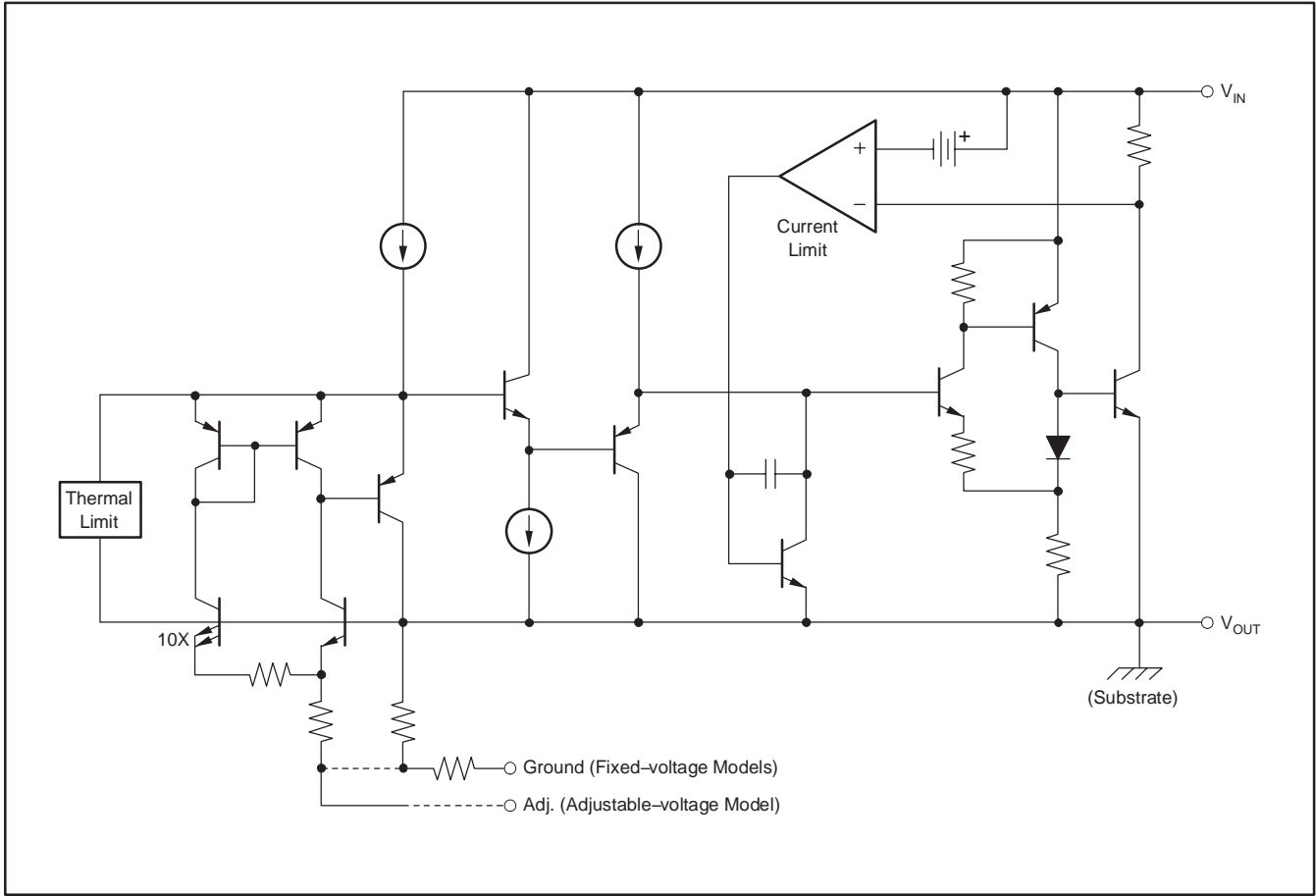

## TYPICAL CHARACTERISTICS

At  $T_A = +25^\circ\text{C}$ , all models, unless otherwise noted.

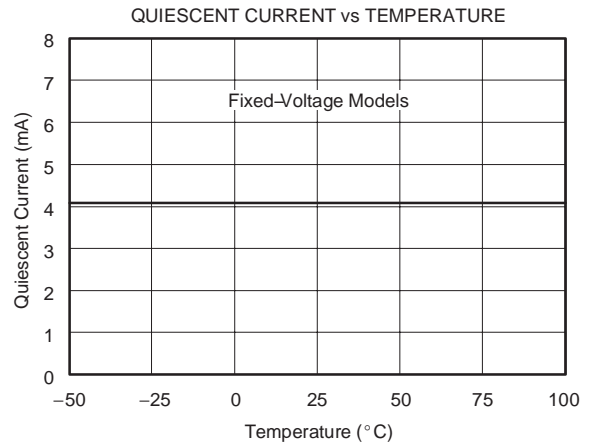
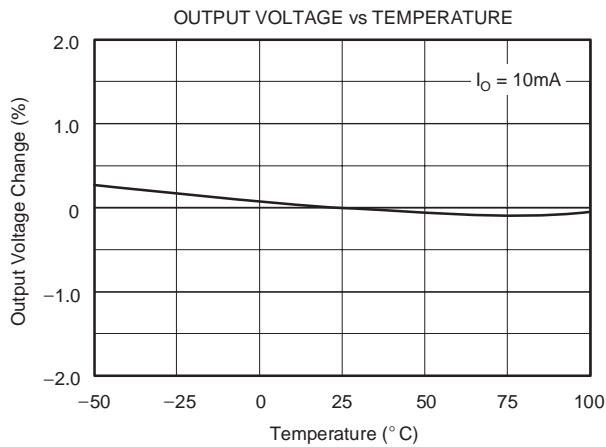
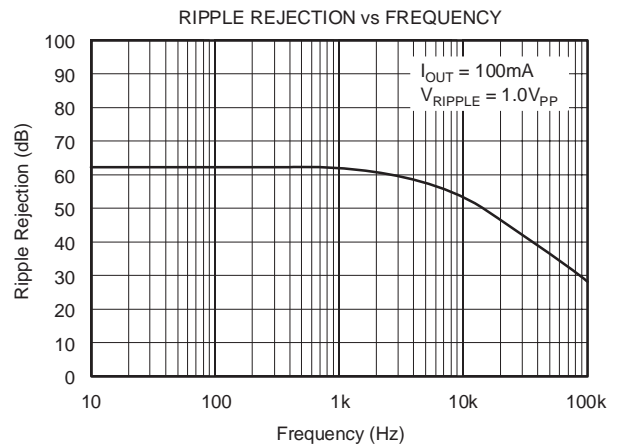
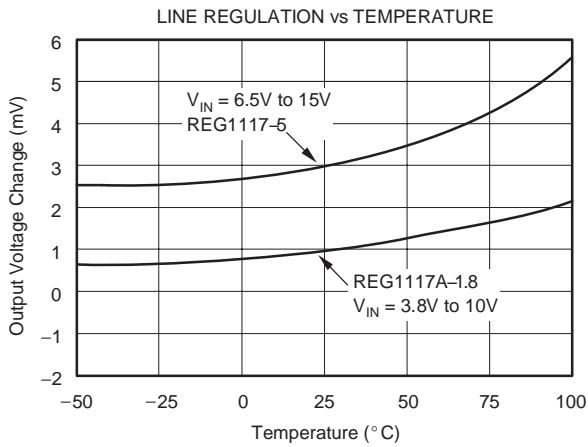
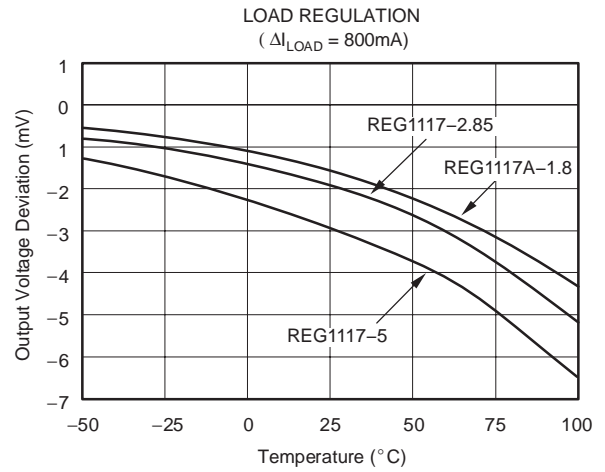
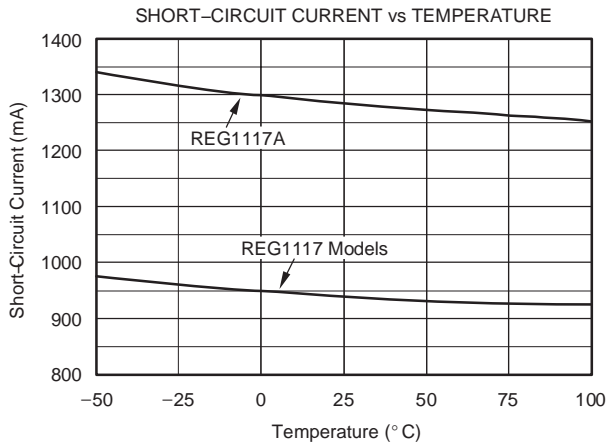

**TYPICAL CHARACTERISTICS (continued)**

At  $T_A = +25^\circ\text{C}$ , all models, unless otherwise noted.

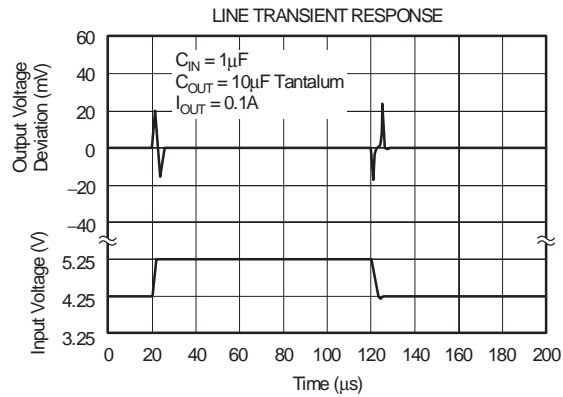
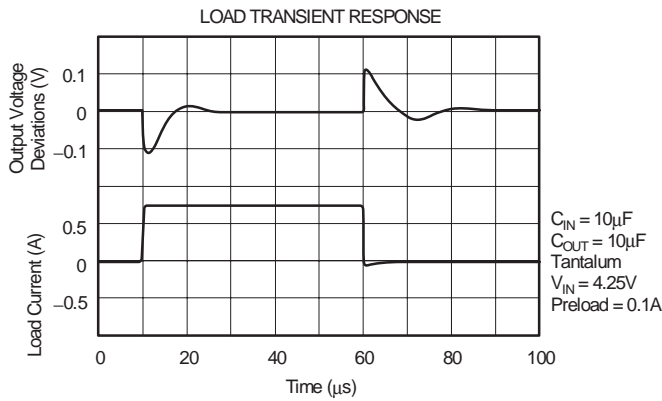

**APPLICATIONS INFORMATION**

Figure 1 shows the basic hookup diagram for fixed-voltage models. All models require an output capacitor for proper operation, and for improving high-frequency load regulation; a 10 $\mu\text{F}$  tantalum capacitor is recommended. Aluminum electrolytic types of 50 $\mu\text{F}$  or greater can also be used. A high-quality capacitor should be used to assure that the ESR (Effective Series Resistance) is less than 0.5 $\Omega$ .

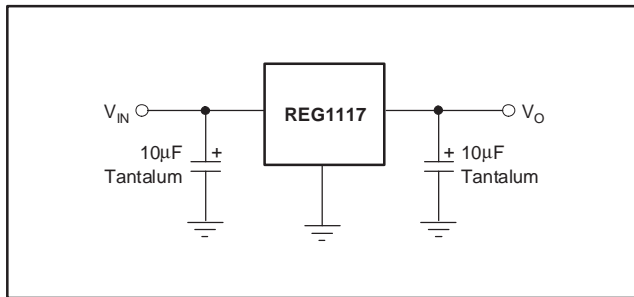

**Figure 1. Fixed-Voltage Model—Basic Connections**

Figure 2 shows a hookup diagram for the adjustable voltage model. Resistor values are shown for some commonly-used output voltages. Values for other voltages can be calculated from the equation shown in Figure 2. For best load regulation, connect  $R_1$  close to the output pin and  $R_2$  close to the ground side of the load as shown.

**THERMAL CONSIDERATIONS**

The REG1117 has current limit and thermal shutdown circuits that protect it from overload. The thermal shutdown activates at approximately  $T_J = 165^\circ\text{C}$ . For continuous operation, however, the junction temperature should not be allowed to exceed  $125^\circ\text{C}$ . Any tendency to activate the thermal shutdown in normal use is an indication of an inadequate heat sink or excessive power dissipation. The power dissipation is equal to:

$$P_D = (V_{IN} - V_{OUT}) I_{OUT}$$

The junction temperature can be calculated by:

$$T_J = T_A + P_D (\theta_{JA})$$

where  $T_A$  is the ambient temperature, and  $\theta_{JA}$  is the junction-to-ambient thermal resistance.

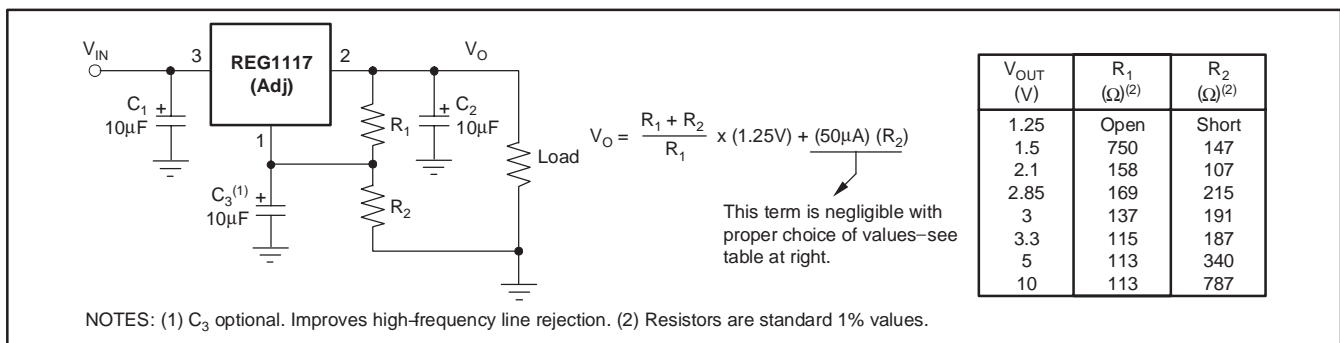

**Figure 2. Adjustable-Voltage Model—Basic Connections**

A simple experiment will determine whether the maximum recommended junction temperature is exceeded in an actual circuit board and mounting configuration: Increase the ambient temperature above that expected in normal operation until the device's thermal shutdown is activated. If this occurs at more than 40°C above the maximum expected ambient temperature, then  $T_J$  will be less than 125°C during normal operation.

The internal protection circuitry of the REG1117 was designed to protect against overload conditions. It was not intended to replace proper heat sinking. Continuously running the REG1117 into thermal shutdown will degrade reliability.

### LAYOUT CONSIDERATIONS

The DDPAK (REG1117F-3.3 and REG1117FA) is a surface-mount power package that has excellent thermal characteristics. For best thermal performance, the mounting tab should be soldered directly to a circuit board copper area, as shown in Figure 3. Increasing the copper area improves heat dissipation. Figure 4 shows typical thermal resistance from junction-to-ambient as a function of the copper area.

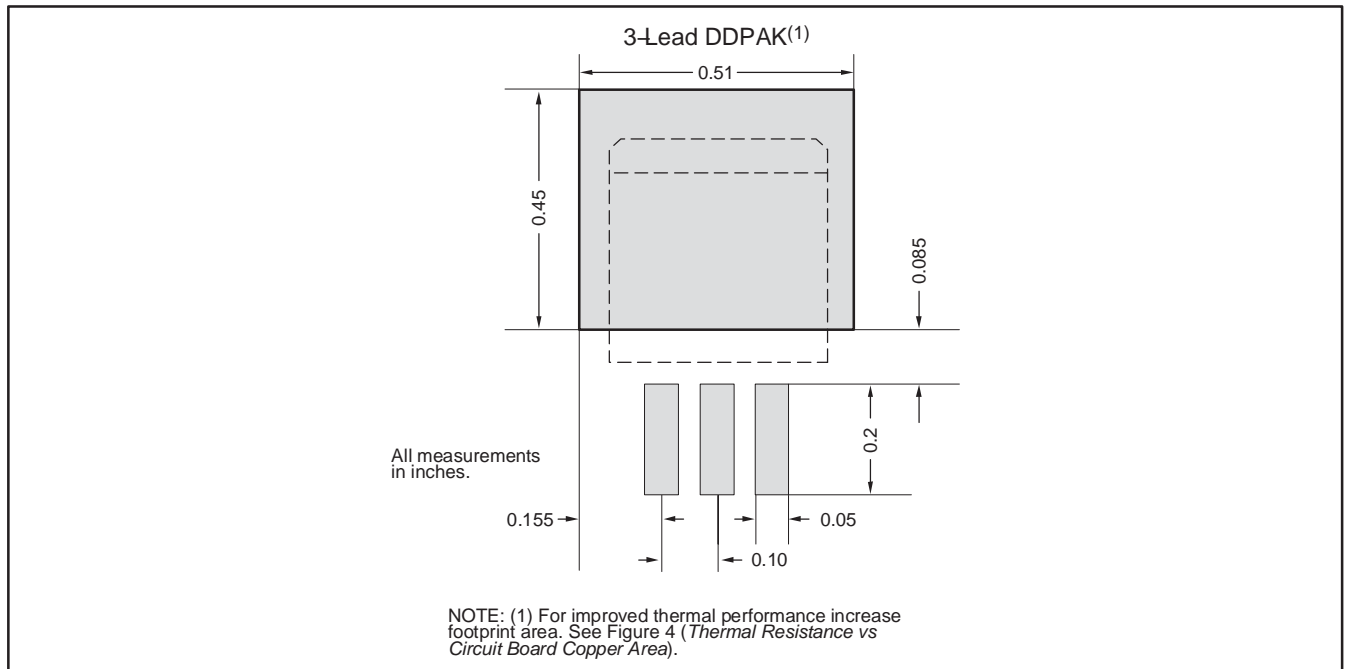

Figure 3. DDPAK Footprint

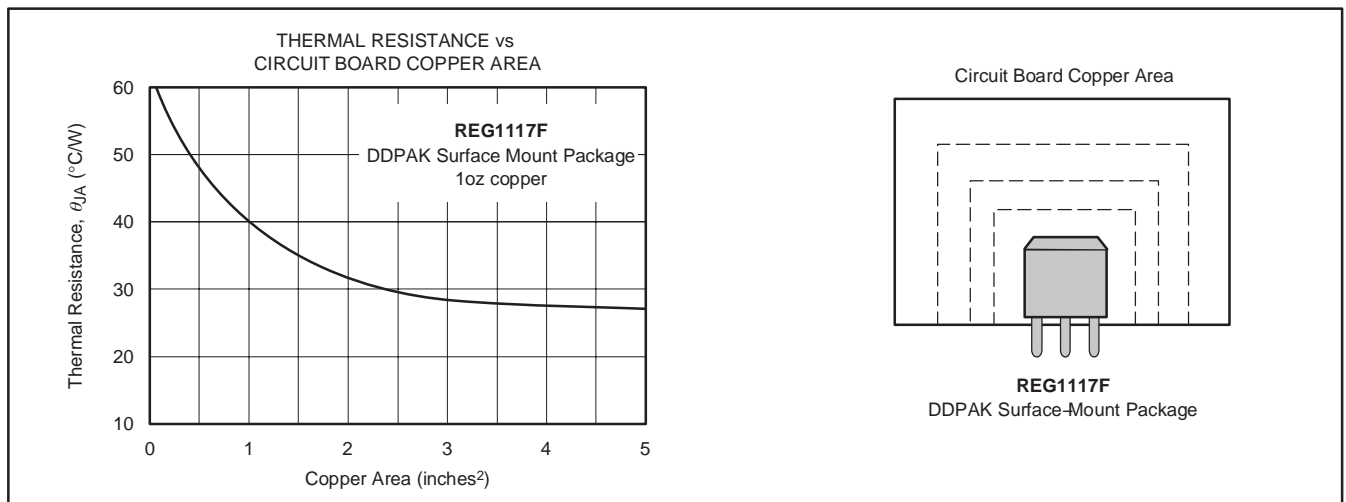

Figure 4. DDPAK Thermal Resistance versus Circuit Board Copper Area

The SOT-223 package derives heat sinking from conduction through its copper leads, especially the large mounting tab. These must be soldered to a circuit board with a substantial amount of copper remaining, as shown in Figure 5. Circuit board traces connecting the tab and the leads should be made as large as practical. The mounting tab of both packages is electrically connected to  $V_{OUT}$ .

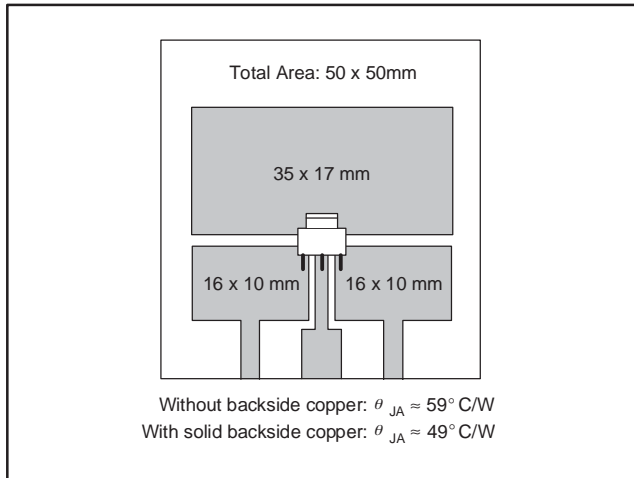

Figure 5. SOT-223 Circuit Board Layout Example

Other nearby circuit traces, including those on the back side of the circuit board, help conduct heat away from the device, even though they may not be electrically connected. Make all nearby copper traces as wide as possible and leave only narrow gaps between traces.

Table 1 shows approximate values of  $\theta_{JA}$  for various circuit board and copper areas for the SOT-223 package. Nearby heat dissipating components, circuit board mounting conditions, and ventilation can dramatically affect the actual  $\theta_{JA}$ . Proper heat sinking significantly increases the maximum power dissipation at a given ambient temperature, as shown in Figure 6.

Table 1. SOT-223  $\theta_{JA}$  for Various Board Configurations

TOTAL PC BOARD AREA	TOPSIDE(1) COPPER AREA	BACKSIDE COPPER AREA	SOT-223 THERMAL RESISTANCE JUNCTION-TO-AMBIENT
2500mm <sup>2</sup>	2500mm <sup>2</sup>	2500mm <sup>2</sup>	46°C/W
2500mm <sup>2</sup>	1250mm <sup>2</sup>	2500mm <sup>2</sup>	47°C/W
2500mm <sup>2</sup>	950mm <sup>2</sup>	2500mm <sup>2</sup>	49°C/W
2500mm <sup>2</sup>	2500mm <sup>2</sup>	0	51°C/W
2500mm <sup>2</sup>	1800mm <sup>2</sup>	0	53°C/W
1600mm <sup>2</sup>	600mm <sup>2</sup>	1600mm <sup>2</sup>	55°C/W
2500mm <sup>2</sup>	1250mm <sup>2</sup>	0	58°C/W
2500mm <sup>2</sup>	915mm <sup>2</sup>	0	59°C/W
1600mm <sup>2</sup>	600mm <sup>2</sup>	0	67°C/W
900mm <sup>2</sup>	340mm <sup>2</sup>	900mm <sup>2</sup>	72°C/W
900mm <sup>2</sup>	340mm <sup>2</sup>	0	85°C/W

(1) Tab is attached to the topside copper.

## SOLDERING METHODS

Both REG1117 packages are suitable for infrared reflow and vapor-phase reflow soldering techniques. The high rate of temperature change that occurs with wave soldering or hand soldering can damage the REG1117.

INSPEC Abstract Number: B91007604, C91012627. Kelly, E.G. "Thermal Characteristics of Surface 5WK9Ω Packages." The Proceedings of SMTCON. Surface Mount Technology Conference and Exposition: Competitive Surface Mount Technology, April 3–6, 1990, Atlantic City, NJ, USA. Abstract Publisher: IC Manage, 1990, Chicago, IL, USA.

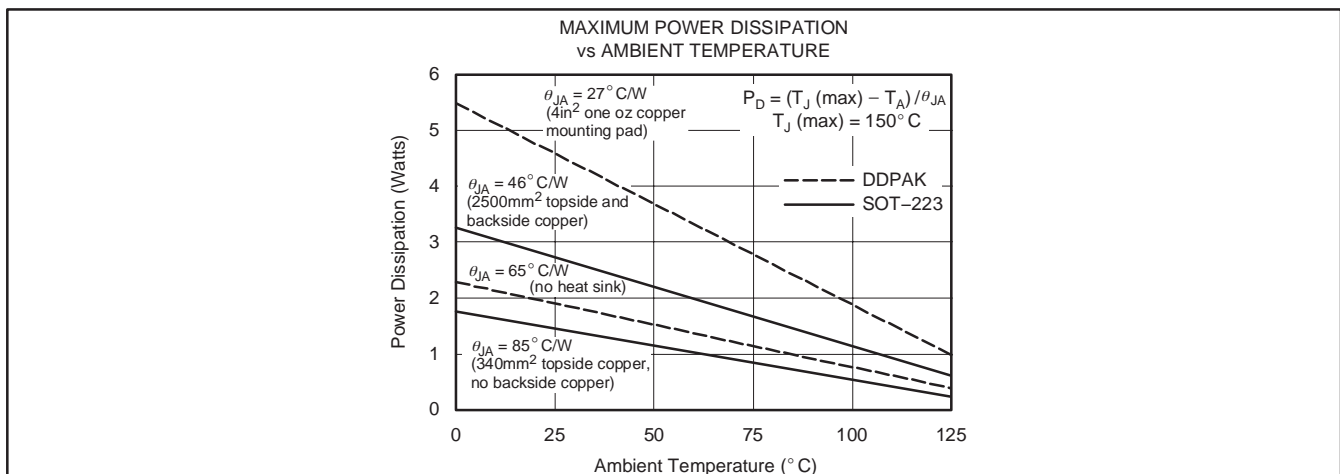

Figure 6. Maximum Power Dissipation versus Ambient Temperature

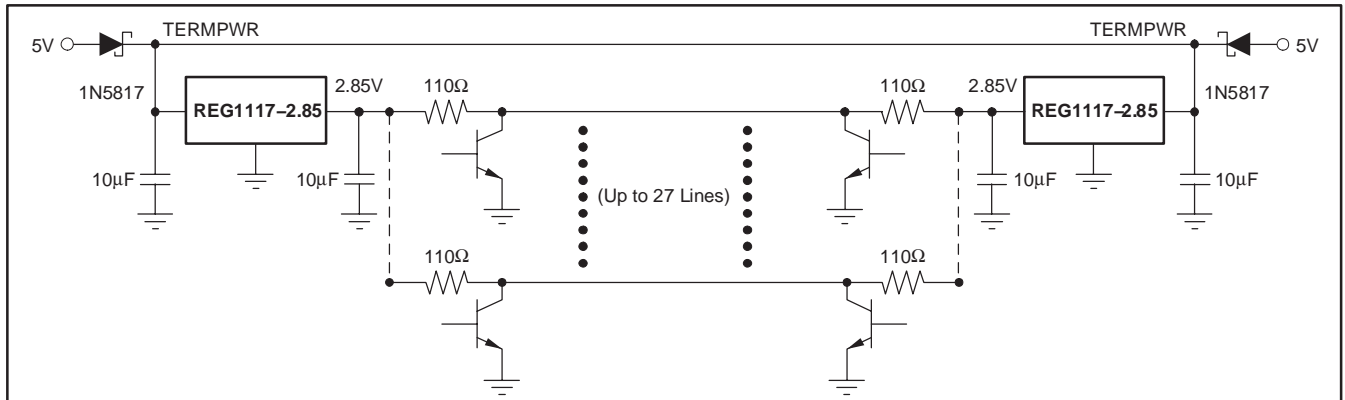

Figure 7. SCSI Active Termination Configuration

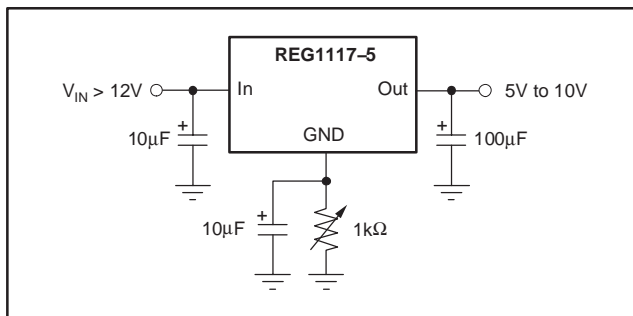

Figure 8. Adjusting Output of Fixed Voltage Models

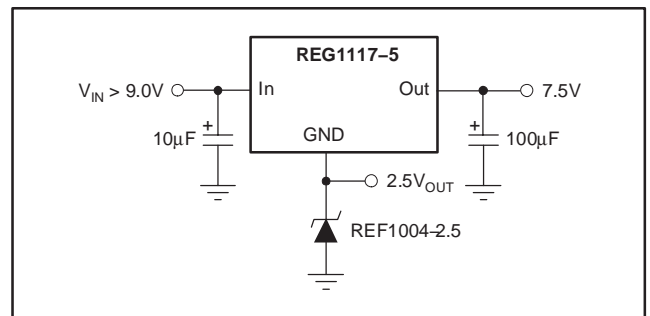

Figure 9. Regulator with Reference

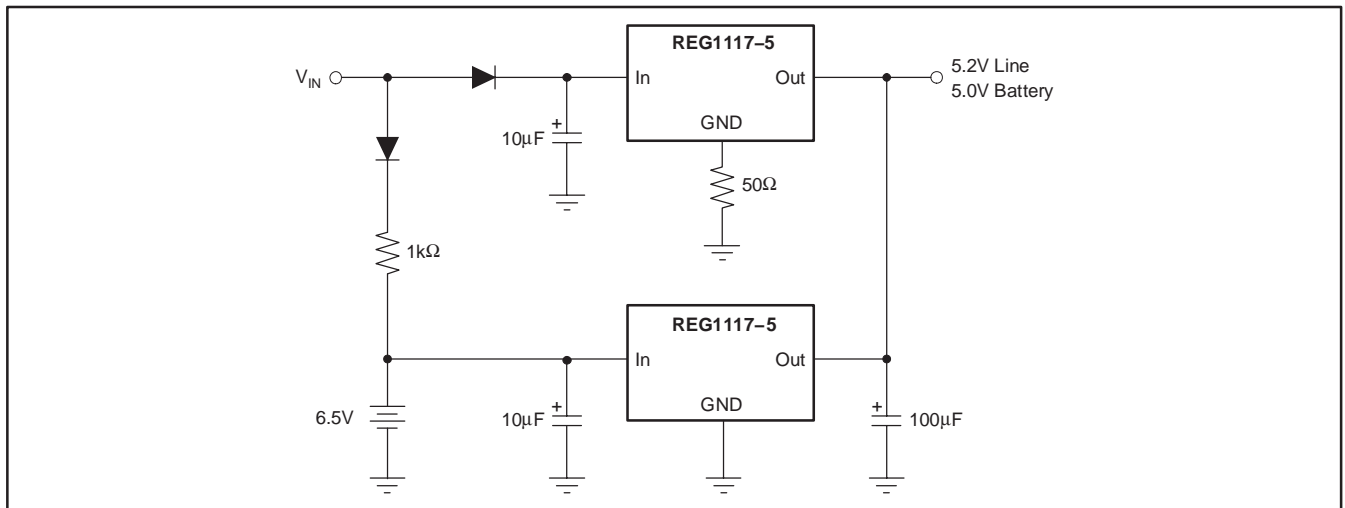

Figure 10. Battery Backed-Up Regulated Supply

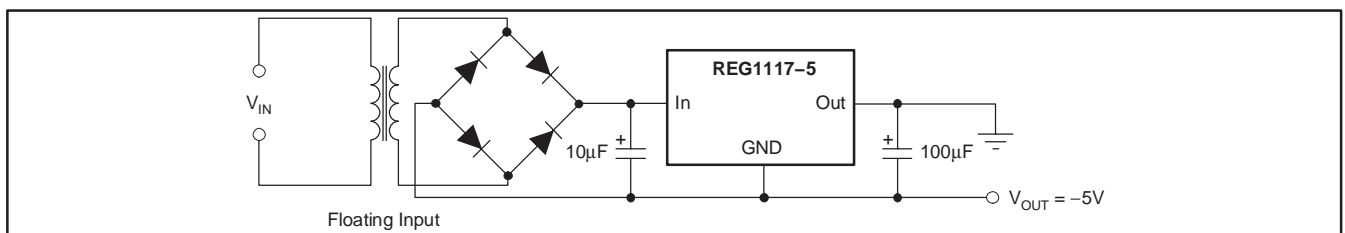
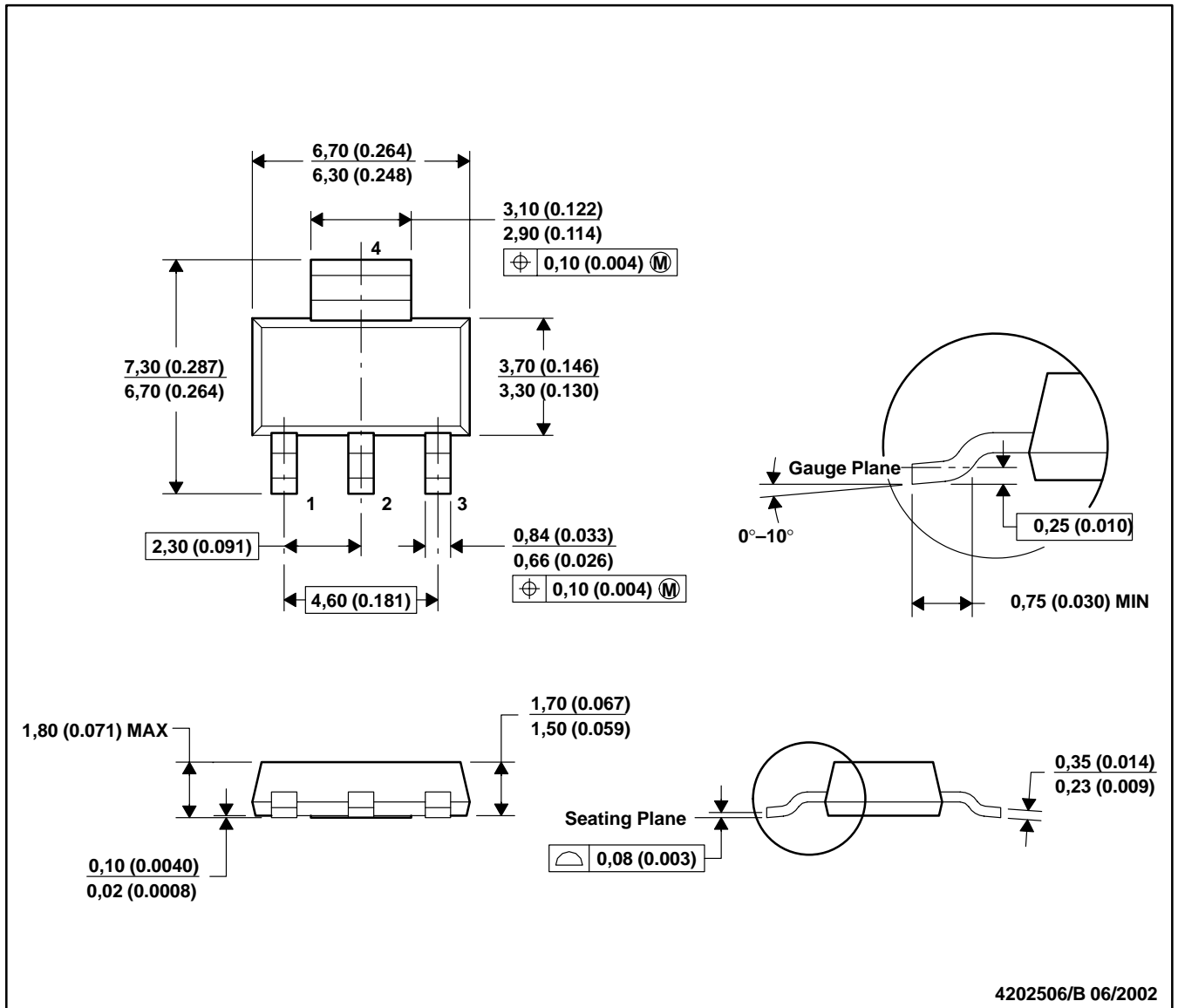

Figure 11. Low Dropout Negative Supply

DCY (R-PDSO-G4)

PLASTIC SMALL-OUTLINE



- NOTES: A. All linear dimensions are in millimeters (inches).  
 B. This drawing is subject to change without notice.  
 C. Body dimensions do not include mold flash or protrusion.  
 D. Falls within JEDEC TO-261 Variation AA.

KTT (R-PSFM-G3)

PLASTIC FLANGE-MOUNT PACKAGE

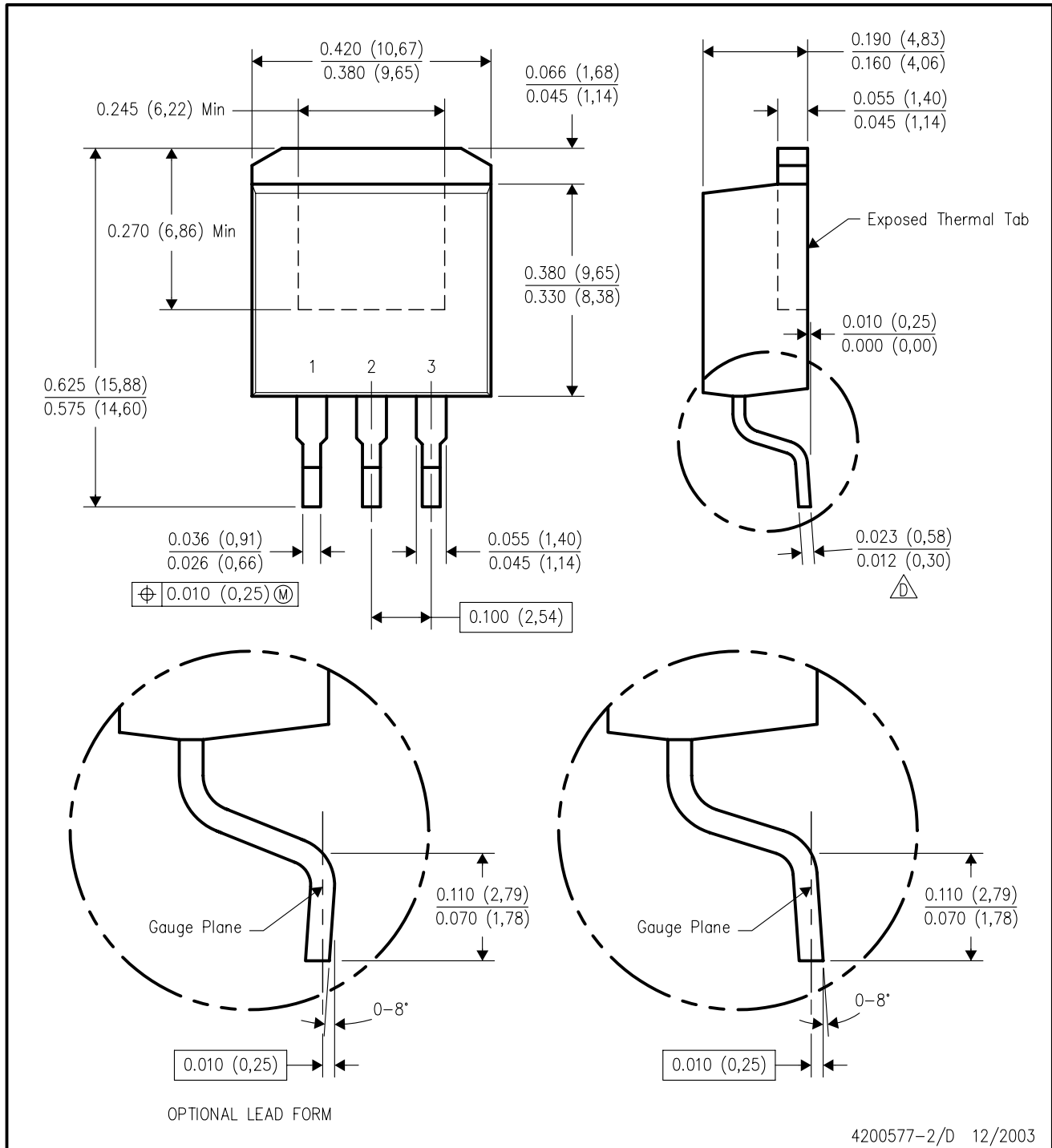

4200577-2/D 12/2003

- NOTES:
- A. All linear dimensions are in inches (millimeters).
  - B. This drawing is subject to change without notice.
  - C. Dimensions do not include mold protrusions, not to exceed 0.006 (0,15).
- (D) Falls within JEDEC TO-263 variation AA, except minimum lead thickness.

**PACKAGING INFORMATION**

Orderable Device	Status <sup>(1)</sup>	Package Type	Package Drawing	Pins	Package Qty	Eco Plan <sup>(2)</sup>	Lead/Ball Finish	MSL Peak Temp <sup>(3)</sup>
REG1117	ACTIVE	SOT-223	DCY	4	80	Green (RoHS & no Sb/Br)	CU NIPDAU	Level-1-260C-UNLIM
REG1117-2.85	ACTIVE	SOT-223	DCY	4	80	Green (RoHS & no Sb/Br)	CU NIPDAU	Level-1-260C-UNLIM
REG1117-2.85/2K5	ACTIVE	SOT-223	DCY	4	2500	Green (RoHS & no Sb/Br)	CU NIPDAU	Level-1-260C-UNLIM
REG1117-2.85/2K5G4	ACTIVE	SOT-223	DCY	4	2500	Green (RoHS & no Sb/Br)	CU NIPDAU	Level-1-260C-UNLIM
REG1117-2.85G4	ACTIVE	SOT-223	DCY	4	80	Green (RoHS & no Sb/Br)	CU NIPDAU	Level-1-260C-UNLIM
REG1117-3.3	ACTIVE	SOT-223	DCY	4	80	Green (RoHS & no Sb/Br)	CU NIPDAU	Level-1-260C-UNLIM
REG1117-3.3/2K5	ACTIVE	SOT-223	DCY	4	2500	Green (RoHS & no Sb/Br)	CU NIPDAU	Level-1-260C-UNLIM
REG1117-3.3/2K5G4	ACTIVE	SOT-223	DCY	4	2500	Green (RoHS & no Sb/Br)	CU NIPDAU	Level-1-260C-UNLIM
REG1117-3.3G4	ACTIVE	SOT-223	DCY	4	80	Green (RoHS & no Sb/Br)	CU NIPDAU	Level-1-260C-UNLIM
REG1117-5	ACTIVE	SOT-223	DCY	4	80	Green (RoHS & no Sb/Br)	CU NIPDAU	Level-1-260C-UNLIM
REG1117-5/2K5	ACTIVE	SOT-223	DCY	4	2500	Green (RoHS & no Sb/Br)	CU NIPDAU	Level-1-260C-UNLIM
REG1117-5/2K5G4	ACTIVE	SOT-223	DCY	4	2500	Green (RoHS & no Sb/Br)	CU NIPDAU	Level-1-260C-UNLIM
REG1117-5G4	ACTIVE	SOT-223	DCY	4	80	Green (RoHS & no Sb/Br)	CU NIPDAU	Level-1-260C-UNLIM
REG1117/2K5	ACTIVE	SOT-223	DCY	4	2500	Green (RoHS & no Sb/Br)	CU NIPDAU	Level-1-260C-UNLIM
REG1117/2K5G4	ACTIVE	SOT-223	DCY	4	2500	Green (RoHS & no Sb/Br)	CU NIPDAU	Level-1-260C-UNLIM
REG1117A	ACTIVE	SOT-223	DCY	4	80	Green (RoHS & no Sb/Br)	CU NIPDAU	Level-1-260C-UNLIM
REG1117A-1.8	ACTIVE	SOT-223	DCY	4	80	Green (RoHS & no Sb/Br)	CU NIPDAU	Level-1-260C-UNLIM
REG1117A-1.8/2K5	ACTIVE	SOT-223	DCY	4	2500	Green (RoHS & no Sb/Br)	CU NIPDAU	Level-1-260C-UNLIM
REG1117A-1.8/2K5G4	ACTIVE	SOT-223	DCY	4	2500	Green (RoHS & no Sb/Br)	CU NIPDAU	Level-1-260C-UNLIM
REG1117A-1.8G4	ACTIVE	SOT-223	DCY	4	80	Green (RoHS & no Sb/Br)	CU NIPDAU	Level-1-260C-UNLIM
REG1117A-2.5	ACTIVE	SOT-223	DCY	4	80	Green (RoHS & no Sb/Br)	CU NIPDAU	Level-1-260C-UNLIM
REG1117A-2.5/2K5	ACTIVE	SOT-223	DCY	4	2500	Green (RoHS & no Sb/Br)	CU NIPDAU	Level-1-260C-UNLIM
REG1117A-2.5/2K5G4	ACTIVE	SOT-223	DCY	4	2500	Green (RoHS & no Sb/Br)	CU NIPDAU	Level-1-260C-UNLIM
REG1117A-2.5G4	ACTIVE	SOT-223	DCY	4	80	Green (RoHS & no Sb/Br)	CU NIPDAU	Level-1-260C-UNLIM
REG1117A/2K5	ACTIVE	SOT-223	DCY	4	2500	Green (RoHS & no Sb/Br)	CU NIPDAU	Level-1-260C-UNLIM

Orderable Device	Status <sup>(1)</sup>	Package Type	Package Drawing	Pins	Package Qty	Eco Plan <sup>(2)</sup>	Lead/Ball Finish	MSL Peak Temp <sup>(3)</sup>
REG1117A/2K5G4	ACTIVE	SOT-223	DCY	4	2500	Green (RoHS & no Sb/Br)	CU NIPDAU	Level-1-260C-UNLIM
REG1117AG4	ACTIVE	SOT-223	DCY	4	80	Green (RoHS & no Sb/Br)	CU NIPDAU	Level-1-260C-UNLIM
REG1117F-3.3	OBSOLETE	DDPAK/TO-263	KTT	3		TBD	Call TI	Call TI
REG1117F-3.3/500	ACTIVE	DDPAK/TO-263	KTT	3	500	Green (RoHS & no Sb/Br)	CU SN	Level-2-260C-1 YEAR
REG1117F-3.3/500G3	ACTIVE	DDPAK/TO-263	KTT	3	500	Green (RoHS & no Sb/Br)	CU SN	Level-2-260C-1 YEAR
REG1117F-3.3KTTT	ACTIVE	DDPAK/TO-263	KTT	3	50	Green (RoHS & no Sb/Br)	CU SN	Level-2-260C-1 YEAR
REG1117F33KTTTG3	ACTIVE	DDPAK/TO-263	KTT	3	50	Green (RoHS & no Sb/Br)	CU SN	Level-2-260C-1 YEAR
REG1117FA	OBSOLETE	DDPAK/TO-263	KTT	3		TBD	Call TI	Call TI
REG1117FA-1.8	OBSOLETE	DDPAK/TO-263	KTT	3		TBD	Call TI	Call TI
REG1117FA-1.8/500	ACTIVE	DDPAK/TO-263	KTT	3	500	Green (RoHS & no Sb/Br)	CU SN	Level-2-260C-1 YEAR
REG1117FA-1.8KTTT	ACTIVE	DDPAK/TO-263	KTT	3	50	Green (RoHS & no Sb/Br)	CU SN	Level-2-260C-1 YEAR
REG1117FA-18/500G3	ACTIVE	DDPAK/TO-263	KTT	3	500	Green (RoHS & no Sb/Br)	CU SN	Level-2-260C-1 YEAR
REG1117FA-2.5	OBSOLETE	DDPAK/TO-263	KTT	3		TBD	Call TI	Call TI
REG1117FA-2.5/500	ACTIVE	DDPAK/TO-263	KTT	3	500	Green (RoHS & no Sb/Br)	CU SN	Level-2-260C-1 YEAR
REG1117FA-2.5KTTT	ACTIVE	DDPAK/TO-263	KTT	3	50	Green (RoHS & no Sb/Br)	CU SN	Level-2-260C-1 YEAR
REG1117FA-25/500G3	ACTIVE	DDPAK/TO-263	KTT	3	500	Green (RoHS & no Sb/Br)	CU SN	Level-2-260C-1 YEAR
REG1117FA-5.0	OBSOLETE	DDPAK/TO-263	KTT	3		TBD	Call TI	Call TI
REG1117FA-5.0/500	ACTIVE	DDPAK/TO-263	KTT	3	500	Green (RoHS & no Sb/Br)	CU SN	Level-2-260C-1 YEAR
REG1117FA-5.0KTTT	ACTIVE	DDPAK/TO-263	KTT	3	50	Green (RoHS & no Sb/Br)	CU SN	Level-2-260C-1 YEAR
REG1117FA-5.0KTTTG	ACTIVE	DDPAK/TO-263	KTT	3	50	Green (RoHS & no Sb/Br)	CU SN	Level-2-260C-1 YEAR
REG1117FA/500	ACTIVE	DDPAK/TO-263	KTT	3	500	Green (RoHS & no Sb/Br)	CU SN	Level-2-260C-1 YEAR
REG1117FA/500G3	ACTIVE	DDPAK/TO-263	KTT	3	500	Green (RoHS & no Sb/Br)	CU SN	Level-2-260C-1 YEAR
REG1117FA1.8KTTTG3	ACTIVE	DDPAK/TO-263	KTT	3	50	Green (RoHS & no Sb/Br)	CU SN	Level-2-260C-1 YEAR
REG1117FA2.5KTTTG3	ACTIVE	DDPAK/TO-263	KTT	3	50	Green (RoHS & no Sb/Br)	CU SN	Level-2-260C-1 YEAR
REG1117FA5.0/500G3	ACTIVE	DDPAK/TO-263	KTT	3	500	Green (RoHS & no Sb/Br)	CU SN	Level-2-260C-1 YEAR
REG1117FAKTTT	ACTIVE	DDPAK/TO-263	KTT	3	50	Green (RoHS & no Sb/Br)	CU SN	Level-2-260C-1 YEAR

Orderable Device	Status <sup>(1)</sup>	Package Type	Package Drawing	Pins	Package Qty	Eco Plan <sup>(2)</sup>	Lead/Ball Finish	MSL Peak Temp <sup>(3)</sup>
REG1117FAKTTTG3	ACTIVE	DDPAK/ TO-263	KTT	3	50	Green (RoHS & no Sb/Br)	CU SN	Level-2-260C-1 YEAR
REG1117G4	ACTIVE	SOT-223	DCY	4	80	Green (RoHS & no Sb/Br)	CU NIPDAU	Level-1-260C-UNLIM

<sup>(1)</sup> The marketing status values are defined as follows:

**ACTIVE:** Product device recommended for new designs.

**LIFEBUY:** TI has announced that the device will be discontinued, and a lifetime-buy period is in effect.

**NRND:** Not recommended for new designs. Device is in production to support existing customers, but TI does not recommend using this part in a new design.

**PREVIEW:** Device has been announced but is not in production. Samples may or may not be available.

**OBSELETE:** TI has discontinued the production of the device.

<sup>(2)</sup> Eco Plan - The planned eco-friendly classification: Pb-Free (RoHS), Pb-Free (RoHS Exempt), or Green (RoHS & no Sb/Br) - please check <http://www.ti.com/productcontent> for the latest availability information and additional product content details.

**TBD:** The Pb-Free/Green conversion plan has not been defined.

**Pb-Free (RoHS):** TI's terms "Lead-Free" or "Pb-Free" mean semiconductor products that are compatible with the current RoHS requirements for all 6 substances, including the requirement that lead not exceed 0.1% by weight in homogeneous materials. Where designed to be soldered at high temperatures, TI Pb-Free products are suitable for use in specified lead-free processes.

**Pb-Free (RoHS Exempt):** This component has a RoHS exemption for either 1) lead-based flip-chip solder bumps used between the die and package, or 2) lead-based die adhesive used between the die and leadframe. The component is otherwise considered Pb-Free (RoHS compatible) as defined above.

**Green (RoHS & no Sb/Br):** TI defines "Green" to mean Pb-Free (RoHS compatible), and free of Bromine (Br) and Antimony (Sb) based flame retardants (Br or Sb do not exceed 0.1% by weight in homogeneous material)

<sup>(3)</sup> MSL, Peak Temp. -- The Moisture Sensitivity Level rating according to the JEDEC industry standard classifications, and peak solder temperature.

**Important Information and Disclaimer:**The information provided on this page represents TI's knowledge and belief as of the date that it is provided. TI bases its knowledge and belief on information provided by third parties, and makes no representation or warranty as to the accuracy of such information. Efforts are underway to better integrate information from third parties. TI has taken and continues to take reasonable steps to provide representative and accurate information but may not have conducted destructive testing or chemical analysis on incoming materials and chemicals. TI and TI suppliers consider certain information to be proprietary, and thus CAS numbers and other limited information may not be available for release.

In no event shall TI's liability arising out of such information exceed the total purchase price of the TI part(s) at issue in this document sold by TI to Customer on an annual basis.

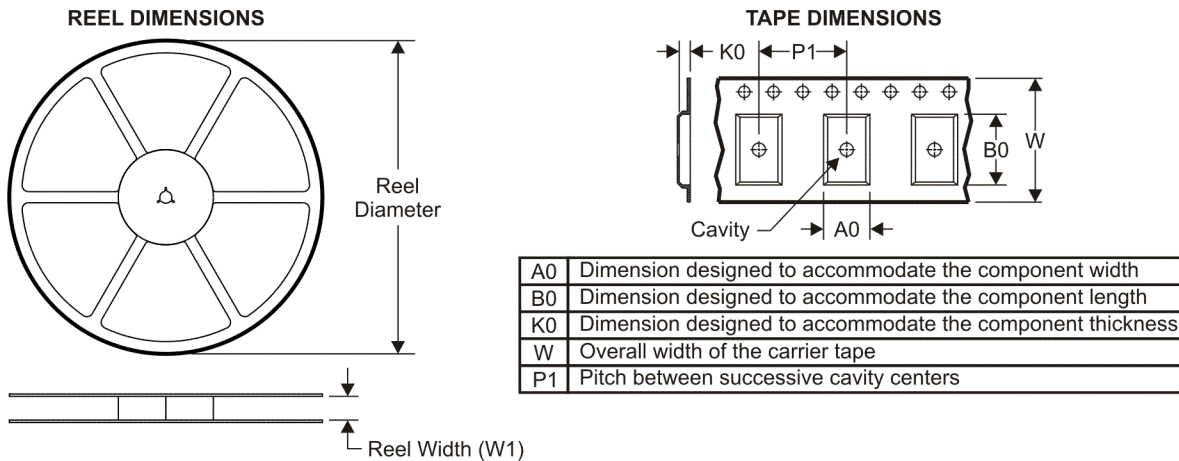
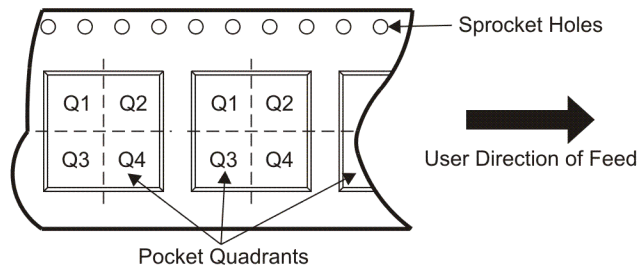
**TAPE AND REEL INFORMATION**

**QUADRANT ASSIGNMENTS FOR PIN 1 ORIENTATION IN TAPE**

\*All dimensions are nominal

Device	Package Type	Package Drawing	Pins	SPQ	Reel Diameter (mm)	Reel Width W1 (mm)	A0 (mm)	B0 (mm)	K0 (mm)	P1 (mm)	W (mm)	Pin1 Quadrant
REG1117-2.85/2K5	SOT-223	DCY	4	2500	330.0	12.4	6.8	7.3	1.88	8.0	12.0	Q3
REG1117-3.3/2K5	SOT-223	DCY	4	2500	330.0	12.4	6.8	7.3	1.88	8.0	12.0	Q3
REG1117-5/2K5	SOT-223	DCY	4	2500	330.0	12.4	6.8	7.3	1.88	8.0	12.0	Q3
REG1117/2K5	SOT-223	DCY	4	2500	330.0	12.4	6.8	7.3	1.88	8.0	12.0	Q3
REG1117A-1.8/2K5	SOT-223	DCY	4	2500	330.0	12.4	6.8	7.3	1.88	8.0	12.0	Q3
REG1117A-2.5/2K5	SOT-223	DCY	4	2500	330.0	12.4	6.8	7.3	1.88	8.0	12.0	Q3
REG1117A/2K5	SOT-223	DCY	4	2500	330.0	12.4	6.8	7.3	1.88	8.0	12.0	Q3
REG1117F-3.3/500	DDPAK/ TO-263	KTT	3	500	330.0	24.4	10.6	15.6	4.9	16.0	24.0	Q2
REG1117F-3.3KTTT	DDPAK/ TO-263	KTT	3	50	330.0	24.4	10.6	15.6	4.9	16.0	24.0	Q2
REG1117FA-1.8/500	DDPAK/ TO-263	KTT	3	500	330.0	24.4	10.6	15.6	4.9	16.0	24.0	Q2
REG1117FA-1.8KTTT	DDPAK/ TO-263	KTT	3	50	330.0	24.4	10.6	15.6	4.9	16.0	24.0	Q2
REG1117FA-2.5/500	DDPAK/ TO-263	KTT	3	500	330.0	24.4	10.6	15.6	4.9	16.0	24.0	Q2
REG1117FA-2.5KTTT	DDPAK/ TO-263	KTT	3	50	330.0	24.4	10.6	15.6	4.9	16.0	24.0	Q2
REG1117FA-5.0/500	DDPAK/ TO-263	KTT	3	500	330.0	24.4	10.6	15.6	4.9	16.0	24.0	Q2

Device	Package Type	Package Drawing	Pins	SPQ	Reel Diameter (mm)	Reel Width W1 (mm)	A0 (mm)	B0 (mm)	K0 (mm)	P1 (mm)	W (mm)	Pin1 Quadrant
	TO-263											
REG1117FA-5.0KTTT	DDPAK/ TO-263	KTT	3	50	330.0	24.4	10.6	15.6	4.9	16.0	24.0	Q2
REG1117FA/500	DDPAK/ TO-263	KTT	3	500	330.0	24.4	10.6	15.6	4.9	16.0	24.0	Q2
REG1117FAKTTT	DDPAK/ TO-263	KTT	3	50	330.0	24.4	10.6	15.6	4.9	16.0	24.0	Q2

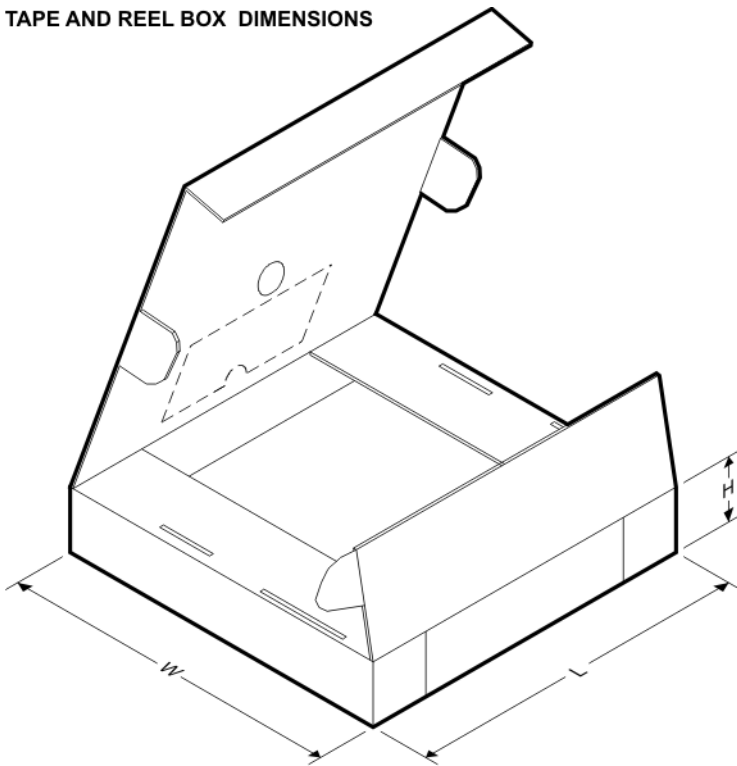
### TAPE AND REEL BOX DIMENSIONS



\*All dimensions are nominal

Device	Package Type	Package Drawing	Pins	SPQ	Length (mm)	Width (mm)	Height (mm)
REG1117-2.85/2K5	SOT-223	DCY	4	2500	358.0	335.0	35.0
REG1117-3.3/2K5	SOT-223	DCY	4	2500	358.0	335.0	35.0
REG1117-5/2K5	SOT-223	DCY	4	2500	358.0	335.0	35.0
REG1117/2K5	SOT-223	DCY	4	2500	358.0	335.0	35.0
REG1117A-1.8/2K5	SOT-223	DCY	4	2500	358.0	335.0	35.0
REG1117A-2.5/2K5	SOT-223	DCY	4	2500	358.0	335.0	35.0
REG1117A/2K5	SOT-223	DCY	4	2500	358.0	335.0	35.0
REG1117F-3.3/500	DDPAK/TO-263	KTT	3	500	346.0	346.0	41.0
REG1117F-3.3KTTT	DDPAK/TO-263	KTT	3	50	346.0	346.0	41.0
REG1117FA-1.8/500	DDPAK/TO-263	KTT	3	500	346.0	346.0	41.0
REG1117FA-1.8KTTT	DDPAK/TO-263	KTT	3	50	346.0	346.0	41.0

---

Device	Package Type	Package Drawing	Pins	SPQ	Length (mm)	Width (mm)	Height (mm)
REG1117FA-2.5/500	DDPAK/TO-263	KTT	3	500	346.0	346.0	41.0
REG1117FA-2.5KTTT	DDPAK/TO-263	KTT	3	50	346.0	346.0	41.0
REG1117FA-5.0/500	DDPAK/TO-263	KTT	3	500	346.0	346.0	41.0
REG1117FA-5.0KTTT	DDPAK/TO-263	KTT	3	50	346.0	346.0	41.0
REG1117FA/500	DDPAK/TO-263	KTT	3	500	346.0	346.0	41.0
REG1117FAKTTT	DDPAK/TO-263	KTT	3	50	346.0	346.0	41.0

KTT (R-PSFM-G3)

PLASTIC FLANGE-MOUNT PACKAGE

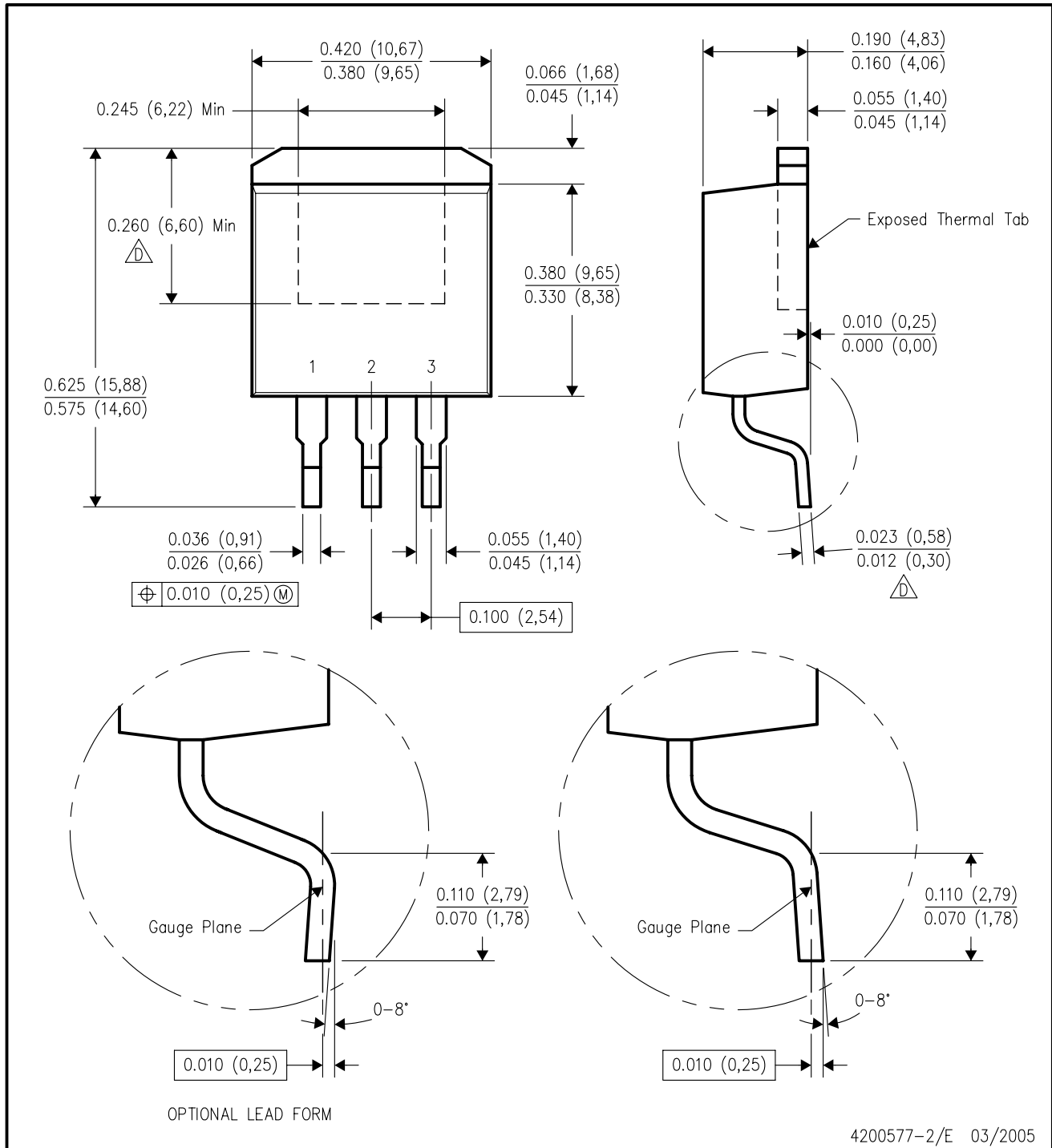

- NOTES:
- A. All linear dimensions are in inches (millimeters).
  - B. This drawing is subject to change without notice.
  - C. Body dimensions do not include mold flash or protrusion. Mold flash or protrusion not to exceed 0.005 (0,13) per side.
- △ Falls within JEDEC TO-263 variation AA, except minimum lead thickness and minimum exposed pad length.

KTT (R-PSFM-G3)

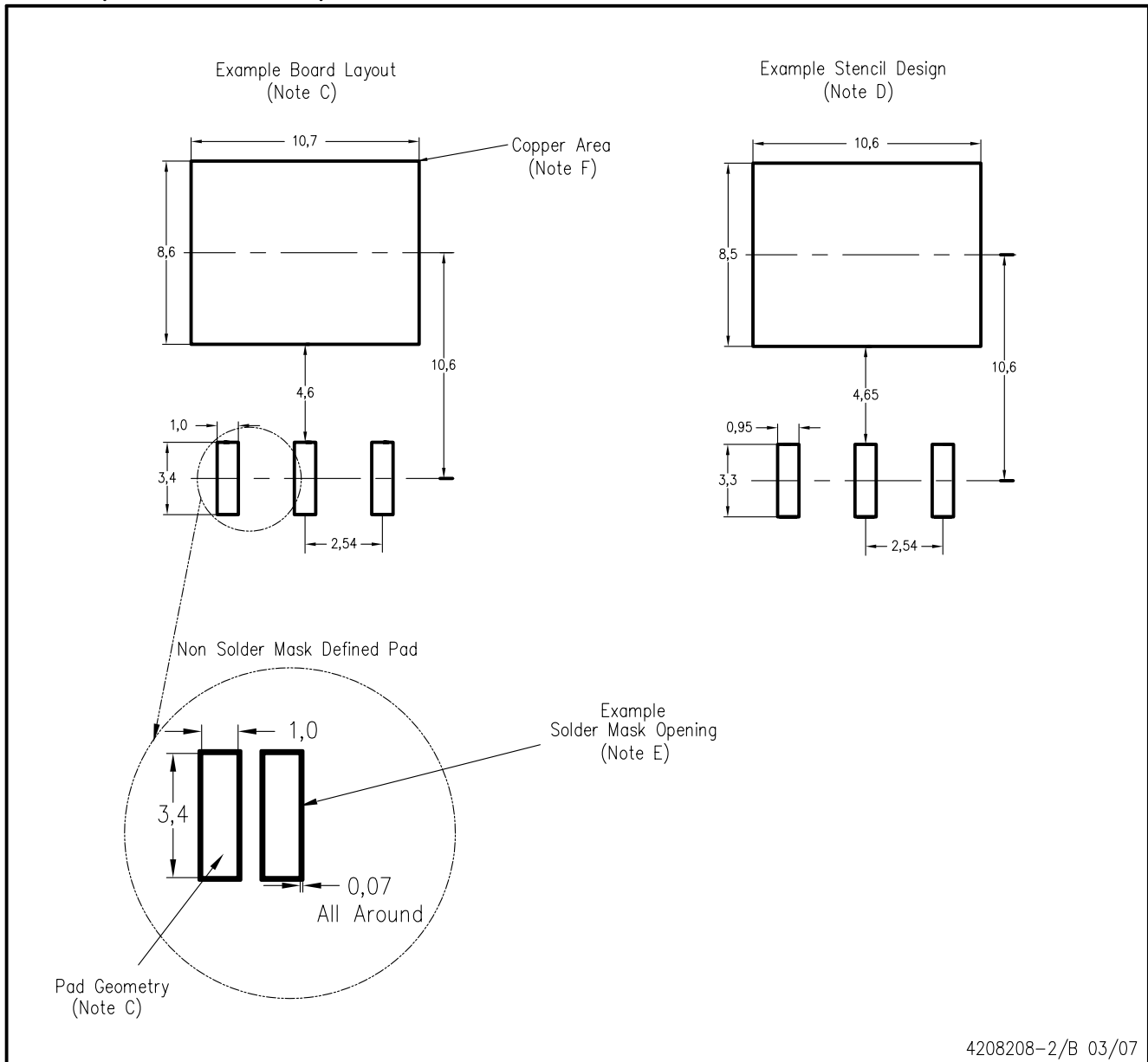

- NOTES:
- A. All linear dimensions are in millimeters.
  - B. This drawing is subject to change without notice.
  - C. Publication IPC-SM-782 is recommended for alternate designs.
  - D. Laser cutting apertures with trapezoidal walls and also rounding corners will offer better paste release. Customers should contact their board assembly site for stencil design recommendations. Refer to IPC-7525.
  - E. Customers should contact their board fabrication site for solder mask tolerances between and around signal pads.
  - F. This package is designed to be soldered to a thermal pad on the board. Refer to the Product Datasheet for specific thermal information, via requirements, and recommended thermal pad size. For thermal pad sizes larger than shown a solder mask defined pad is recommended in order to maintain the solderable pad geometry while increasing copper area.

DCY (R-PDSO-G4)

PLASTIC SMALL-OUTLINE

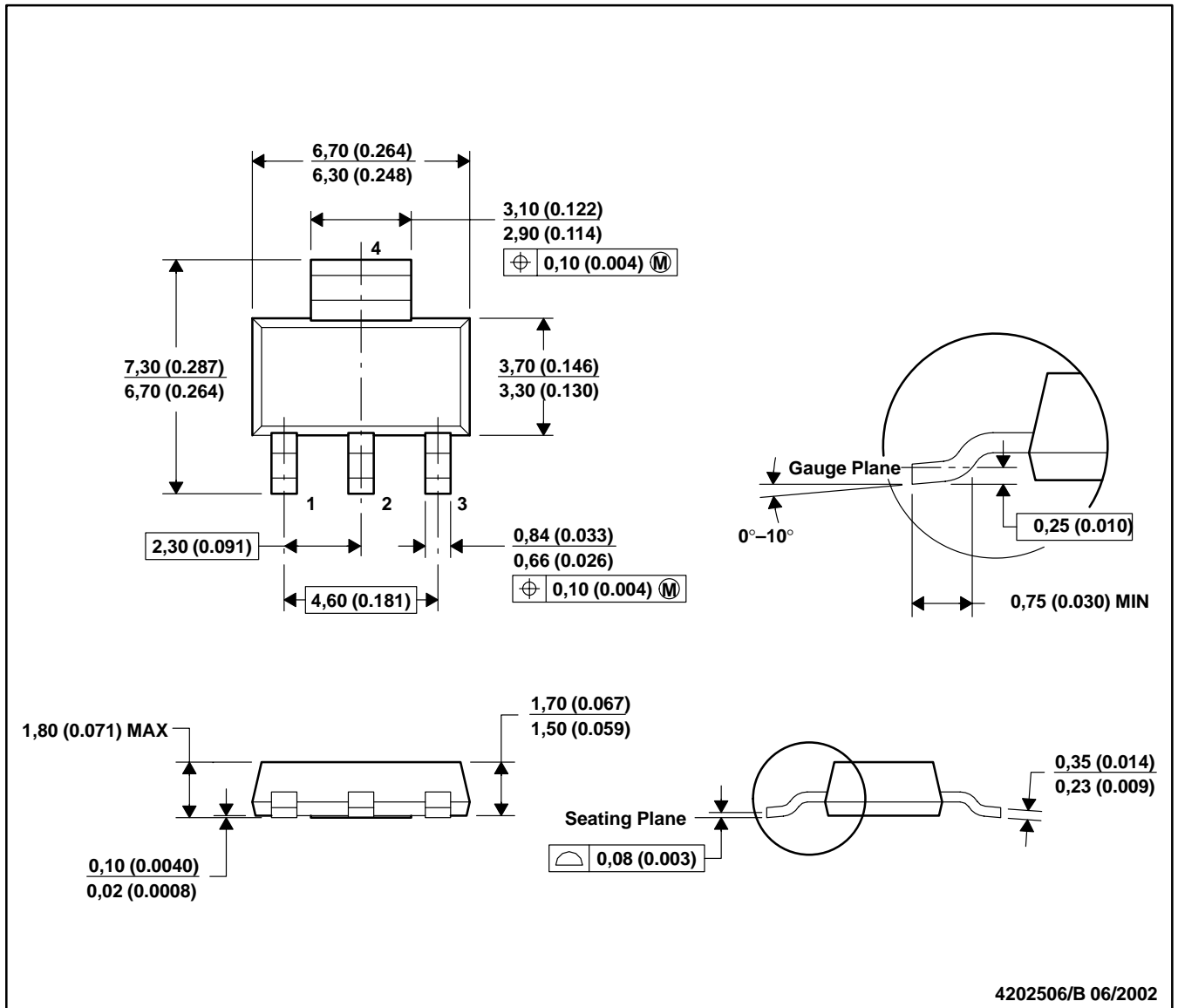

- NOTES: A. All linear dimensions are in millimeters (inches).  
 B. This drawing is subject to change without notice.  
 C. Body dimensions do not include mold flash or protrusion.  
 D. Falls within JEDEC TO-261 Variation AA.

## IMPORTANT NOTICE

Texas Instruments Incorporated and its subsidiaries (TI) reserve the right to make corrections, modifications, enhancements, improvements, and other changes to its products and services at any time and to discontinue any product or service without notice. Customers should obtain the latest relevant information before placing orders and should verify that such information is current and complete. All products are sold subject to TI's terms and conditions of sale supplied at the time of order acknowledgment.

TI warrants performance of its hardware products to the specifications applicable at the time of sale in accordance with TI's standard warranty. Testing and other quality control techniques are used to the extent TI deems necessary to support this warranty. Except where mandated by government requirements, testing of all parameters of each product is not necessarily performed.

TI assumes no liability for applications assistance or customer product design. Customers are responsible for their products and applications using TI components. To minimize the risks associated with customer products and applications, customers should provide adequate design and operating safeguards.

TI does not warrant or represent that any license, either express or implied, is granted under any TI patent right, copyright, mask work right, or other TI intellectual property right relating to any combination, machine, or process in which TI products or services are used. Information published by TI regarding third-party products or services does not constitute a license from TI to use such products or services or a warranty or endorsement thereof. Use of such information may require a license from a third party under the patents or other intellectual property of the third party, or a license from TI under the patents or other intellectual property of TI.

Reproduction of TI information in TI data books or data sheets is permissible only if reproduction is without alteration and is accompanied by all associated warranties, conditions, limitations, and notices. Reproduction of this information with alteration is an unfair and deceptive business practice. TI is not responsible or liable for such altered documentation. Information of third parties may be subject to additional restrictions.

Resale of TI products or services with statements different from or beyond the parameters stated by TI for that product or service voids all express and any implied warranties for the associated TI product or service and is an unfair and deceptive business practice. TI is not responsible or liable for any such statements.

TI products are not authorized for use in safety-critical applications (such as life support) where a failure of the TI product would reasonably be expected to cause severe personal injury or death, unless officers of the parties have executed an agreement specifically governing such use. Buyers represent that they have all necessary expertise in the safety and regulatory ramifications of their applications, and acknowledge and agree that they are solely responsible for all legal, regulatory and safety-related requirements concerning their products and any use of TI products in such safety-critical applications, notwithstanding any applications-related information or support that may be provided by TI. Further, Buyers must fully indemnify TI and its representatives against any damages arising out of the use of TI products in such safety-critical applications.

TI products are neither designed nor intended for use in military/aerospace applications or environments unless the TI products are specifically designated by TI as military-grade or "enhanced plastic." Only products designated by TI as military-grade meet military specifications. Buyers acknowledge and agree that any such use of TI products which TI has not designated as military-grade is solely at the Buyer's risk, and that they are solely responsible for compliance with all legal and regulatory requirements in connection with such use.

TI products are neither designed nor intended for use in automotive applications or environments unless the specific TI products are designated by TI as compliant with ISO/TS 16949 requirements. Buyers acknowledge and agree that, if they use any non-designated products in automotive applications, TI will not be responsible for any failure to meet such requirements.

Following are URLs where you can obtain information on other Texas Instruments products and application solutions:

### Products

Amplifiers	<a href="http://amplifier.ti.com">amplifier.ti.com</a>
Data Converters	<a href="http://dataconverter.ti.com">dataconverter.ti.com</a>
DLP® Products	<a href="http://www.dlp.com">www.dlp.com</a>
DSP	<a href="http://dsp.ti.com">dsp.ti.com</a>
Clocks and Timers	<a href="http://www.ti.com/clocks">www.ti.com/clocks</a>
Interface	<a href="http://interface.ti.com">interface.ti.com</a>
Logic	<a href="http://logic.ti.com">logic.ti.com</a>
Power Mgmt	<a href="http://power.ti.com">power.ti.com</a>
Microcontrollers	<a href="http://microcontroller.ti.com">microcontroller.ti.com</a>
RFID	<a href="http://www.ti-rfid.com">www.ti-rfid.com</a>
RF/IF and ZigBee® Solutions	<a href="http://www.ti.com/lprf">www.ti.com/lprf</a>

### Applications

Audio	<a href="http://www.ti.com/audio">www.ti.com/audio</a>
Automotive	<a href="http://www.ti.com/automotive">www.ti.com/automotive</a>
Broadband	<a href="http://www.ti.com/broadband">www.ti.com/broadband</a>
Digital Control	<a href="http://www.ti.com/digitalcontrol">www.ti.com/digitalcontrol</a>
Medical	<a href="http://www.ti.com/medical">www.ti.com/medical</a>
Military	<a href="http://www.ti.com/military">www.ti.com/military</a>
Optical Networking	<a href="http://www.ti.com/opticalnetwork">www.ti.com/opticalnetwork</a>
Security	<a href="http://www.ti.com/security">www.ti.com/security</a>
Telephony	<a href="http://www.ti.com/telephony">www.ti.com/telephony</a>
Video & Imaging	<a href="http://www.ti.com/video">www.ti.com/video</a>
Wireless	<a href="http://www.ti.com/wireless">www.ti.com/wireless</a>

Mailing Address: Texas Instruments, Post Office Box 655303, Dallas, Texas 75265  
Copyright © 2009, Texas Instruments Incorporated