



60mA, 5.0V, Buck/Boost Charge Pump in ThinSOT-23 and ThinQFN

FEATURES

- **Wide Input Range: 1.8V to 5.5V**
- **Automatic Step-Up/Step-Down Operation**
- **Low Input Current Ripple**
- **Low Output Voltage Ripple**
- **Minimum Number of External Components—No Inductors**
- **1MHz Internal Oscillator Allows Small Capacitors**
- **Shutdown Mode**
- **Thermal and Current Limit Protection**
- **Six Output Voltages Available:**
 - 5.5V, 5.0V, 3.3V, 3.0V, 2.7V, 2.5V
- **Small Packages:**
 - SOT23-6
 - TSOT23-6 (**REG71055** and **REG71050** Only)
 - TQFN-6 (2×2×0.8mm; **REG71050** Only)
- **Evaluation Modules Available:**
 - **REG710EVM-33**, **REG710EVM-5**

APPLICATIONS

- **Smart Card Readers**
- **SIM Card Supplies**
- **Cellular Phones**
- **Portable Communication Devices**
- **Personal Digital Assistants**
- **Notebook and Palm-Top Computers**
- **Modems**
- **Electronic Games**
- **Handheld Meters**
- **PCMCIA Cards**
- **Card Buses**
- **White LED Drivers**
- **LCD Displays**
- **Battery Backup Supplies**

DESCRIPTION

The REG710 is a switched capacitor voltage converter that produces a regulated, low-ripple output voltage from an unregulated input voltage. A wide input supply voltage of 1.8V to 5.5V makes the REG710 ideal for a variety of battery sources, such as single-cell Li-Ion, or two- and three-cell nickel- or alkaline-based chemistries.

The input voltage may vary above and below the output voltage and the output remains in regulation. It works equally well for step-up or step-down applications without the need for an inductor, providing low EMI dc/dc conversion. The high switching frequency allows the use of small surface-mount capacitors, saving board space and reducing cost. The REG710 is thermally protected and current limited, protecting the load and the regulator during fault conditions. Typical ground pin current (quiescent current) is 65µA with no load, and less than 1µA in shutdown mode.

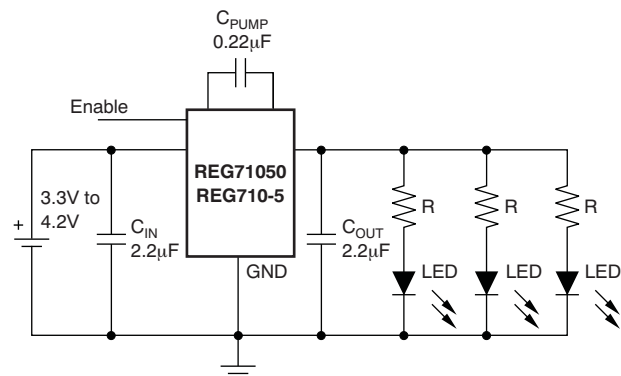

REG710 Used in White LED Backlight Application



Please be aware that an important notice concerning availability, standard warranty, and use in critical applications of Texas Instruments semiconductor products and disclaimers thereto appears at the end of this data sheet.

All trademarks are the property of their respective owners.



This integrated circuit can be damaged by ESD. Texas Instruments recommends that all integrated circuits be handled with appropriate precautions. Failure to observe proper handling and installation procedures can cause damage.

ESD damage can range from subtle performance degradation to complete device failure. Precision integrated circuits may be more susceptible to damage because very small parametric changes could cause the device not to meet its published specifications.

ORDERING INFORMATION⁽¹⁾

PRODUCT	OUTPUT VOLTAGE	PACKAGE-LEAD	PACKAGE DESIGNATOR	SPECIFIED TEMPERATURE RANGE	PACKAGE MARKING ⁽²⁾	ORDERING NUMBER	TRANSPORT MEDIA, QUANTITY
5.5V Output							
REG71055DDC	5.5V	TSOT23-6	DDC	–40°C to +85°C	R10H	REG71055DDCT	Tape and Reel, 250
						REG71055DDCR	Tape and Reel, 3000
5V Output							
REG710NA-5	5.0V	SOT23-6	DBV	–40°C to +85°C	R10B	REG710NA-5/250	Tape and Reel, 250
						REG710NA-5/3K	Tape and Reel, 3000
REG71050DDC	5.0V	TSOT23-6	DDC	–40°C to +85°C	GAAI	REG71050DDCT	Tape and Reel, 250
						REG71050DDCR	Tape and Reel, 3000
REG71050DRV	5.0V	TQFN-6	DRV	–40°C to +85°C	CFF	REG71050DRVT	Tape and Reel, 250
						REG71050DRVR	Tape and Reel, 3000
3.3V Output							
REG710NA-3.3	3.3V	SOT23-6	DBV	–40°C to +85°C	R10C	REG710NA-3.3/250	Tape and Reel, 250
						REG710NA-3.3/3K	Tape and Reel, 3000
3V Output							
REG710NA-3	3.0V	SOT23-6	DBV	–40°C to +85°C	R10D	REG710NA-3/250	Tape and Reel, 250
						REG710NA-3/3K	Tape and Reel, 3000
2.7V Output							
REG710NA-2.7	2.7V	SOT23-6	DBV	–40°C to +85°C	R10F	REG710NA-2.7/250	Tape and Reel, 250
						REG710NA-2.7/3K	Tape and Reel, 3000
2.5V Output							
REG710NA-2.5	2.5V	SOT23-6	DBV	–40°C to +85°C	R10G	REG710NA-2.5/250	Tape and Reel, 250
						REG710NA-2.5/3K	Tape and Reel, 3000

- (1) For the most current package and ordering information see the Package Option Addendum at the end of this document, or see the TI web site at www.ti.com.
- (2) Voltage is marked on reel. Add on row with the following data: Product: REG71050DRV Output Voltage: 5.0V Package-Lead: TQFN Package Designator: DRV Specified Temp range: –40C to +85C Package marking: CFF Ordering Number: REG71050DRVT (Tape and Reel, 250) REG71050DRVR (Tape and Reel, 3000)

ABSOLUTE MAXIMUM RATINGS⁽¹⁾

	REG710	UNIT
Supply voltage	–0.3 to +6.0	V
Enable input	–0.3 to V_{IN}	V
Output short-circuit duration	Indefinite	
Operating temperature range	–55 to +125	°C
Storage temperature range	–65 to +150	°C
Junction temperature	–55 to +150	°C
Lead temperature (soldering, 10s)	+260	°C

- (1) Stresses above these ratings may cause permanent damage. Exposure to absolute maximum conditions for extended periods may degrade device reliability. These are stress ratings only, and functional operation of the device at these or any other conditions beyond those specified is not implied.

PIN CONFIGURATIONS

TSOT23/SOT23
(TOP VIEW)

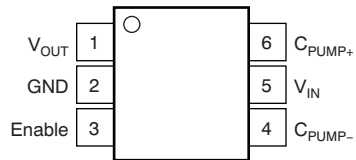

TQFN
(TOP VIEW)

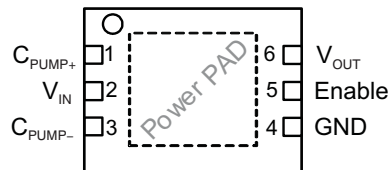

SIMPLIFIED BLOCK DIAGRAM

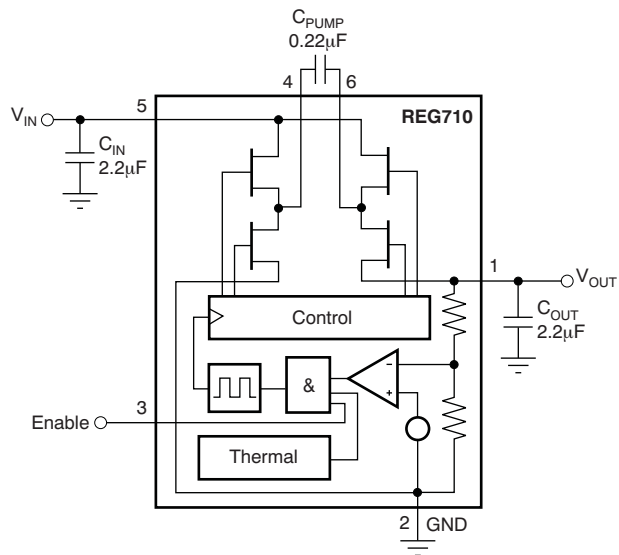

ELECTRICAL CHARACTERISTICS

Boldface limits apply over the specified temperature range, $T_A = -40^\circ\text{C}$ to $+85^\circ\text{C}$.

At $T_A = +25^\circ\text{C}$, $V_{IN} = V_{OUT}/2 + 0.75\text{V}$, $I_{OUT} = 10\text{mA}$, $C_{IN} = C_{OUT} = 2.2\mu\text{F}$, $C_{PUMP} = 0.22\mu\text{F}$, and $V_{ENABLE} = 1.3\text{V}$, unless otherwise noted.

PARAMETER	TEST CONDITIONS	REG710			UNIT
		MIN	TYP	MAX	
INPUT VOLTAGE					
Tested Startup					
REG71055	See conditions under Output Voltage with a resistive load no lower than typical V_{OUT}/I_{OUT} .	3.0		5.5	V
REG710-5		2.7		5.5	V
All other models		1.8		5.5	V
OUTPUT VOLTAGE					
REG71055	$I_{OUT} \leq 10\text{mA}$, $3.0\text{V} \leq V_{IN} \leq 5.5\text{V}$	5.2	5.5	5.8	V
	$I_{OUT} \leq 30\text{mA}$, $3.25\text{V} \leq V_{IN} \leq 5.5\text{V}$	5.2	5.5	5.8	V
REG710-5, REG71050	$I_{OUT} \leq 10\text{mA}$, $2.7\text{V} \leq V_{IN} \leq 5.5\text{V}$	4.7	5.0	5.3	V
	$I_{OUT} \leq 30\text{mA}$, $3.0\text{V} \leq V_{IN} \leq 5.5\text{V}$	4.7	5.0	5.3	V
	$I_{OUT} \leq 60\text{mA}$, $3.3\text{V} \leq V_{IN} \leq 4.2\text{V}$	4.6	5.0	5.4	V
REG710-3.3	$I_{OUT} \leq 10\text{mA}$, $1.8\text{V} \leq V_{IN} \leq 5.5\text{V}$	3.10	3.3	3.50	V
	$I_{OUT} \leq 30\text{mA}$, $2.2\text{V} \leq V_{IN} \leq 5.5\text{V}$	3.10	3.3	3.50	V
REG710-3	$I_{OUT} \leq 10\text{mA}$, $1.8\text{V} \leq V_{IN} \leq 5.5\text{V}$	2.82	3.0	3.18	V
	$I_{OUT} \leq 30\text{mA}$, $2.2\text{V} \leq V_{IN} \leq 5.5\text{V}$	2.82	3.0	3.18	V
REG710-2.7	$I_{OUT} \leq 10\text{mA}$, $1.8\text{V} \leq V_{IN} \leq 5.5\text{V}$	2.54	2.7	2.86	V
	$I_{OUT} \leq 30\text{mA}$, $2.0\text{V} \leq V_{IN} \leq 5.5\text{V}$	2.54	2.7	2.86	V
REG710-2.5	$I_{OUT} \leq 10\text{mA}$, $1.8\text{V} \leq V_{IN} \leq 5.5\text{V}$	2.35	2.5	2.65	V
	$I_{OUT} \leq 30\text{mA}$, $2.0\text{V} \leq V_{IN} \leq 5.5\text{V}$	2.35	2.5	2.65	V
OUTPUT CURRENT					
Nominal		30			mA
Short-circuit ⁽¹⁾			100		mA
OSCILLATOR FREQUENCY⁽²⁾					
			1.0		MHz
EFFICIENCY⁽³⁾					
	$I_{OUT} = 10\text{mA}$, $V_{IN} = 1.8\text{V}$, REG710-3.3		90		%
RIPPLE VOLTAGE⁽⁴⁾					
	$I_{OUT} = 30\text{mA}$		35		mV _{PP}
ENABLE CONTROL					
	$V_{IN} = 1.8\text{V}$ to 5.5V				
Logic high input voltage		1.3		V_{IN}	V
Logic low input voltage		-0.2		0.4	V
Logic high input current				100	nA
Logic low input current				100	nA
THERMAL SHUTDOWN					
Shutdown temperature			160		$^\circ\text{C}$
Shutdown recovery			140		$^\circ\text{C}$
SUPPLY CURRENT					
(Quiescent current)	$I_{OUT} = 0\text{mA}$		65	100	μA
In shutdown mode	$V_{IN} = 1.8\text{V}$ to 5.5V , Enable = 0V		0.01	1	μA
TEMPERATURE RANGE					
Specified ambient temperature	T_A	-40		+85	$^\circ\text{C}$
Operating ambient temperature	T_A	-55		+125	$^\circ\text{C}$
Storage ambient temperature	T_A	-65		+150	$^\circ\text{C}$
Thermal resistance	θ_{JA}		200		$^\circ\text{C}/\text{W}$
	SOT23-6		220		$^\circ\text{C}/\text{W}$
	TSOT23-6		75		$^\circ\text{C}/\text{W}$
	TQFN-6				$^\circ\text{C}/\text{W}$

(1) The supply current is twice the output short-circuit current.

(2) The converter regulates by enabling and disabling periods of switching cycles. The switching frequency is the oscillator frequency during an active period.

(3) See efficiency curves for other V_{IN}/V_{OUT} configurations.

(4) Effective series resistance (ESR) of capacitors is $< 0.1\Omega$.

TYPICAL CHARACTERISTICS

At $T_A = +25^\circ\text{C}$, $V_{IN} = V_{OUT}/2 + 0.75\text{V}$, $I_{OUT} = 5\text{mA}$, $C_{IN} = C_{OUT} = 2.2\mu\text{F}$, $C_{PUMP} = 0.22\mu\text{F}$, and $V_{ENABLE} = 1.3\text{V}$, unless otherwise noted.

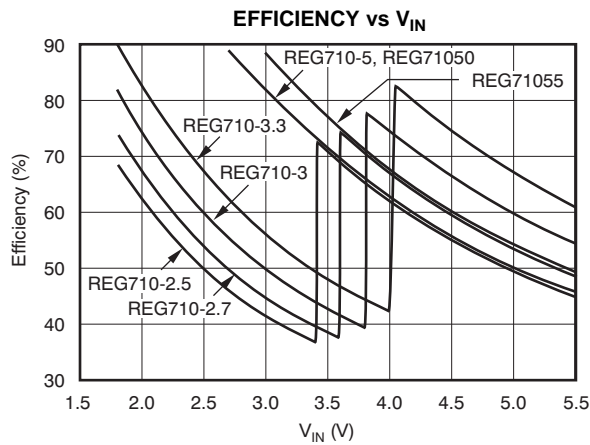

Figure 1.

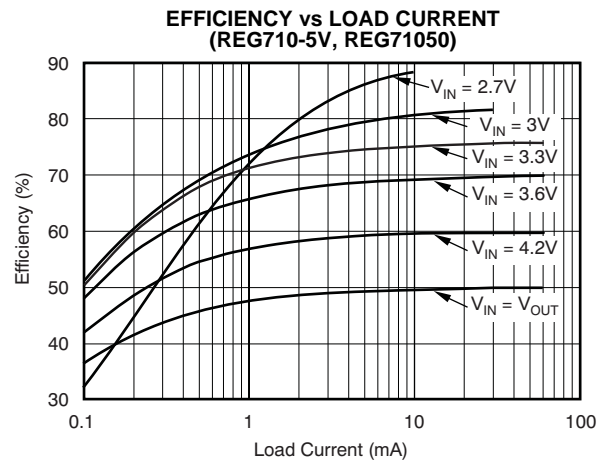

Figure 2.

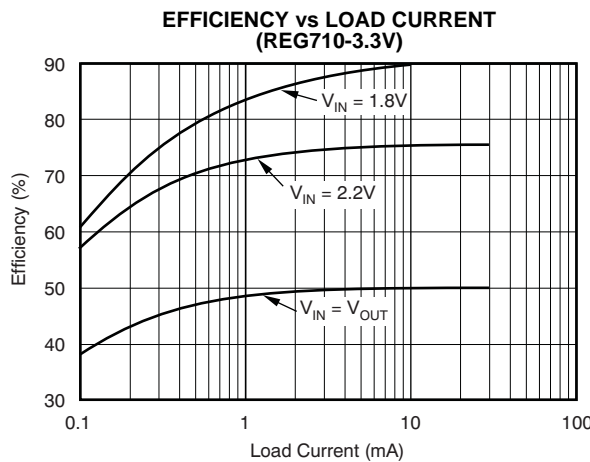

Figure 3.

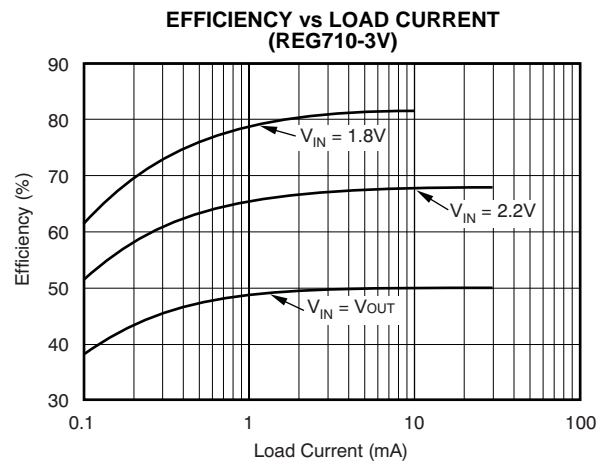

Figure 4.

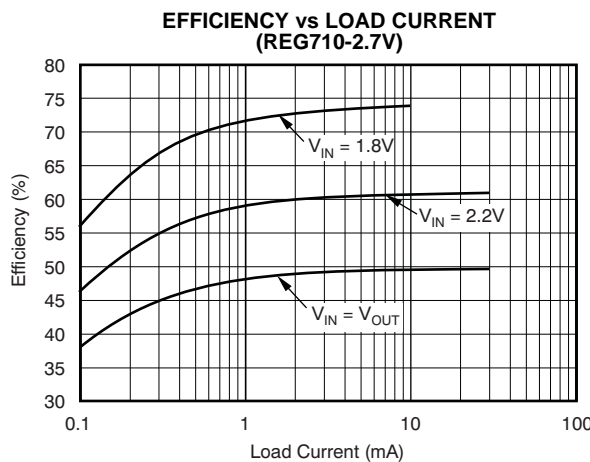

Figure 5.

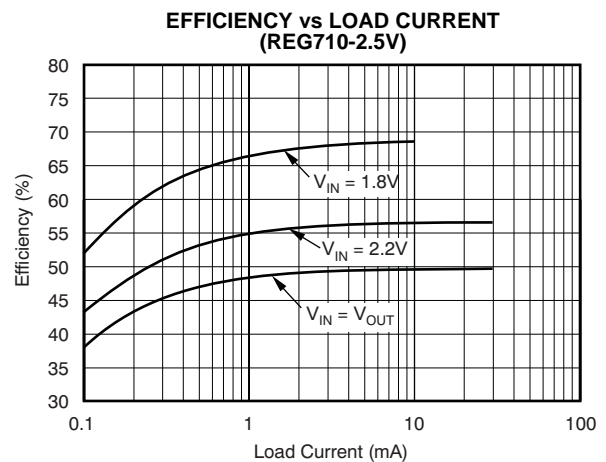

Figure 6.

TYPICAL CHARACTERISTICS (continued)

At $T_A = +25^\circ\text{C}$, $V_{IN} = V_{OUT}/2 + 0.75\text{V}$, $I_{OUT} = 5\text{mA}$, $C_{IN} = C_{OUT} = 2.2\mu\text{F}$, $C_{PUMP} = 0.22\mu\text{F}$, and $V_{ENABLE} = 1.3\text{V}$, unless otherwise noted.

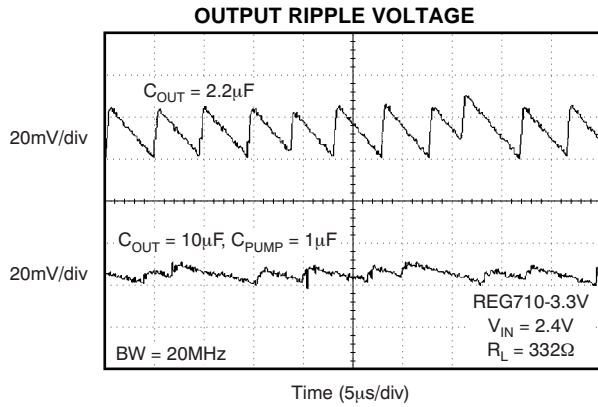

Figure 13.

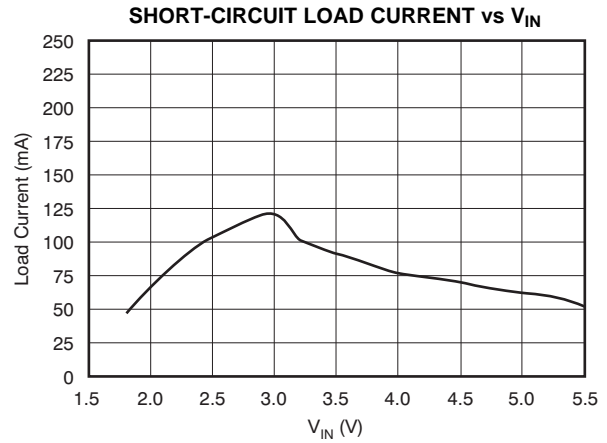

Figure 14.

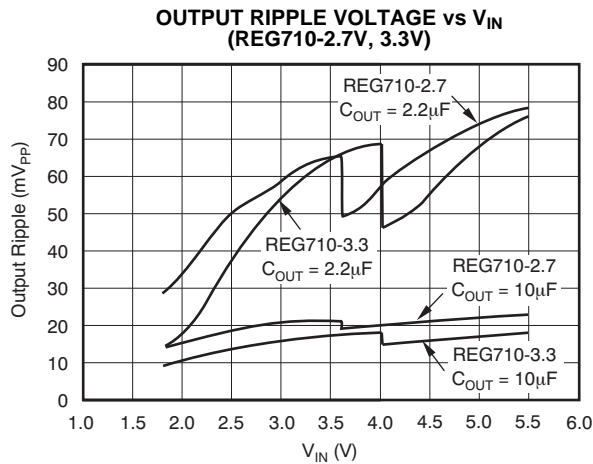

Figure 15.

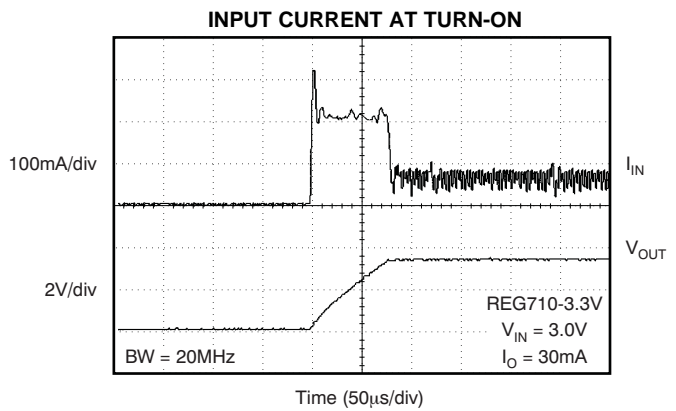

Figure 16.

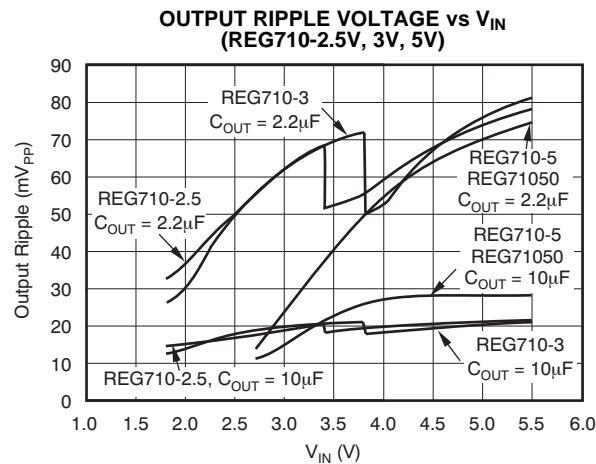

Figure 17.

THEORY OF OPERATION

The REG710 regulated charge pump provides a regulated output voltage for input voltages ranging from less than the output to greater than the output. This is accomplished by automatic mode switching within the device. When the input voltage is greater than the required output, the unit functions as a variable frequency switch-mode regulator. This operation is shown in Figure 18. Transistors Q_1 and Q_3 are held off, Q_4 is on, and Q_2 is switched as needed to maintain a regulated output voltage.

When the input voltage is less than the required output voltage, the device switches to a step-up or boost mode of operation, as shown in Figure 19.

A conversion clock of 50% duty cycle is generated. During the first half cycle the FET switches are configured as shown in Figure 19A, and C_{PUMP} charges to V_{IN} .

During the second half cycle the FET switches are configured as shown in Figure 19B, and the voltage on C_{PUMP} is added to V_{IN} . The output voltage is regulated by skipping clock cycles as necessary.

PEAK CURRENT REDUCTION

In normal operation, the charging of the pump and output capacitors usually leads to relatively high peak input currents which can be much higher than that of the average load current. The regulator incorporates circuitry to limit the input peak current, lowering the total EMI production of the device and lowering output voltage ripple and input current ripple. Input capacitor (C_{IN}) supplies most of the charge required by input current peaks.

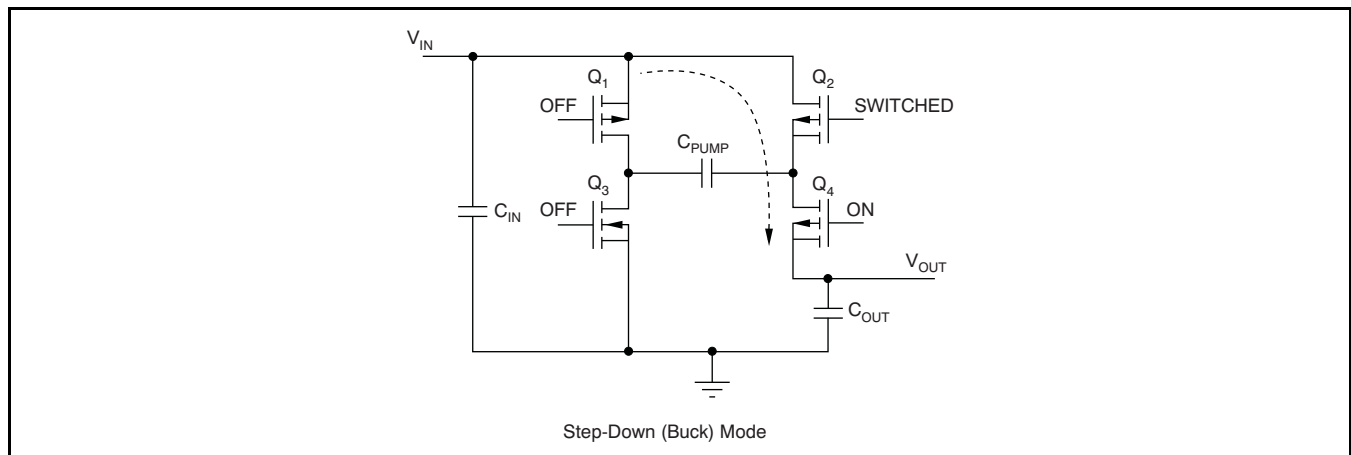

Figure 18. Simplified Schematic of the REG710 Operating in the Step-Down Mode

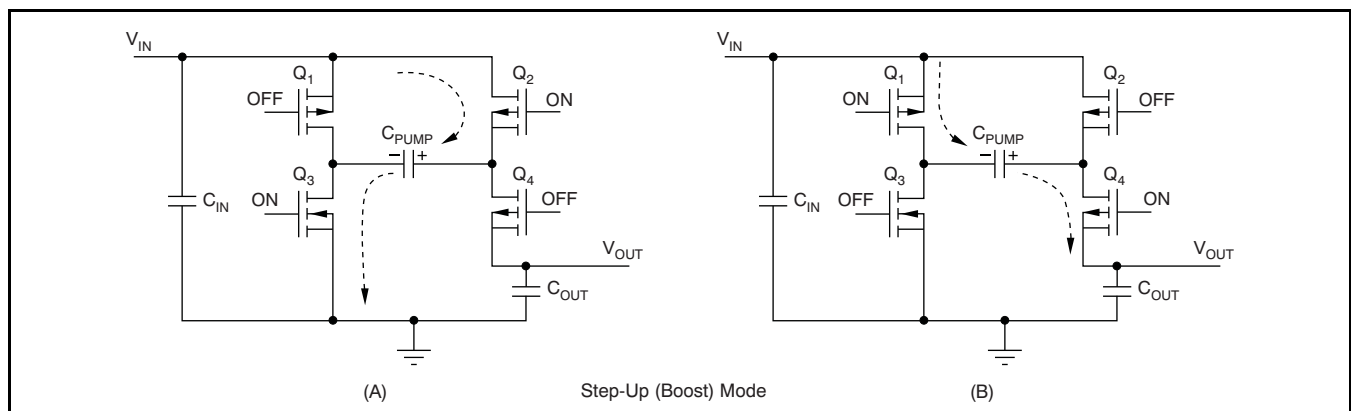

Figure 19. Simplified Schematic of the REG710 Operating in the Step-Up or Boost Mode

PROTECTION

The regulator has thermal shutdown circuitry that protects it from damage caused by overload conditions. The thermal protection circuitry disables the output when the junction temperature reaches approximately +160°C, allowing the device to cool. When the junction temperature cools to approximately +140°C, the output circuitry is automatically reenabled. Continuously running the regulator into thermal shutdown can degrade reliability. The regulator also provides current limit to protect itself and the load.

SHUTDOWN MODE

The EN pin enables the IC when pulled high and places it into energy-saving shutdown mode when pulled low. When in shutdown mode, the output is disconnected from the input and the quiescent current is reduced to 0.01µA typical. This shutdown mode functionality is only valid when V_{IN} is above the minimum recommended operating voltage. The EN pin cannot be left floating and must be actively terminated either high or low.

CAPACITOR SELECTION

For minimum output voltage ripple, the output capacitor C_{OUT} should be a ceramic, surface-mount type. Tantalum capacitors generally have a higher effective series resistance (ESR) and may contribute to higher output voltage ripple. Leaded capacitors also increase ripple due to the higher inductance of the package itself. To achieve best operation with low input voltage and high load current, the input and

pump capacitors (C_{IN} and C_{PUMP} , respectively) should also be surface-mount ceramic types. In all cases, X7R or X5R dielectric are recommended. See the typical operating circuit shown in [Figure 20](#) for component values.

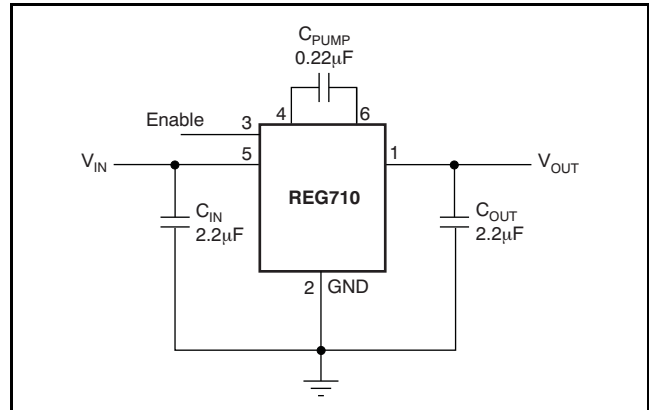

Figure 20. Typical Operating Circuit

With light loads or higher input voltage, a smaller 0.1µF pump capacitor (C_{PUMP}) and smaller 1µF input and output capacitors (C_{IN} and C_{OUT} , respectively) can be used. To minimize output voltage ripple, increase the output capacitor, C_{OUT} , to 10µF or larger.

The capacitors listed in [Table 1](#) can be used with the REG710. This table is only a representative list of compatible parts.

Table 1. Suggested Capacitors

MANUFACTURER	PART NUMBER	VALUE	TOLERANCE	DIELECTRIC MATERIAL	PACKAGE SIZE	RATED WORKING VOLTAGE
Kemet	C1206C255K8RAC	2.2µF	±10%	X7R	1206	10V
	C1206C224K8RAC	0.22µF	±10%	X7R	1206	10V
Panasonic	ECJ-2YBOJ225K	2.2µF	±10%	X5R	805	6.3V
	ECJ-2VBIC224K	0.22µF	±10%	X7R	805	16V
	ECJ-2VBIC104	0.1µF	±10%	X7R	805	16V
Taiyo Yuden	EMK316BJ225KL	2.2µF	±10%	X7R	1206	16V
	TKM316BJ224KF	0.22µF	±10%	X7R	1206	25V

EFFICIENCY

The efficiency of the charge pump regulator varies with the output voltage version, the applied input voltage, the load current, and the internal operation mode of the device.

The approximate efficiency is given by:

$$\text{Efficiency (\%)} = V_{\text{OUT}} / (2 \times V_{\text{IN}}) \times 100$$

(step-up operating mode)

or

$$\frac{V_{\text{OUT}}}{V_{\text{IN}}} \times 100$$

(step-down operating mode)

Table 2 lists the approximate values of the input voltage at which the device changes internal operating mode. See efficiency curves in the [Typical Characteristics](#) section for various loads and input voltages.

Table 2. Operating Mode Change versus V_{IN}

PRODUCT	OPERATING MODE CHANGES AT V_{IN} OF
REG710-2.5	> 3.2V
REG710-2.7	> 3.4V
REG710-3	> 3.7V
REG710-3.3	> 4.0V
REG710-5, REG71050, REG71055	Step-up only

LAYOUT

Large transient currents flow in the V_{IN} , V_{OUT} , and GND traces. To minimize both input and output ripple, keep the capacitors as close as possible to the regulator using short, direct circuit traces.

A suggested printed circuit board (PCB) routing is shown in Figure 21. The trace lengths from the input and output capacitors have been kept as short as possible.

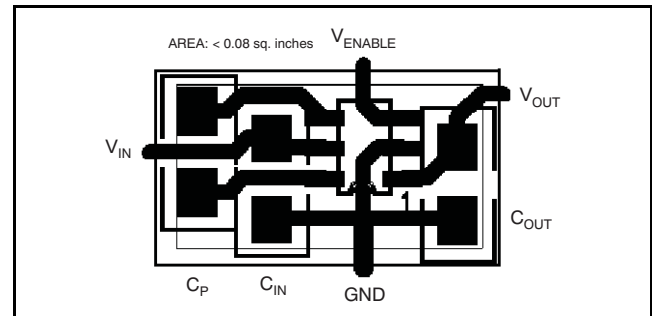

Figure 21. Suggested PCB Design for Minimum Ripple

APPLICATION CIRCUITS

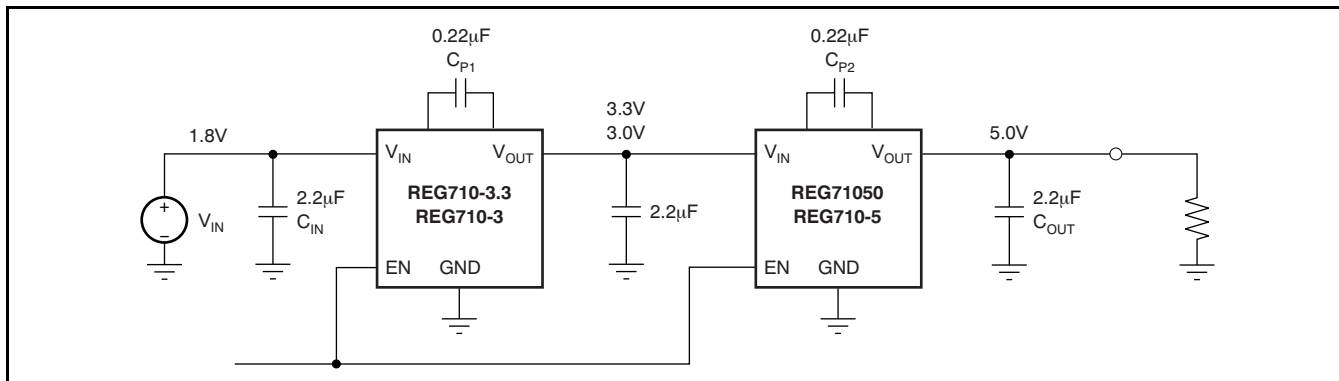

Figure 22. REG710 Circuit for Step-Up Operation from 1.8V to 5.0V with 10mA Output Current

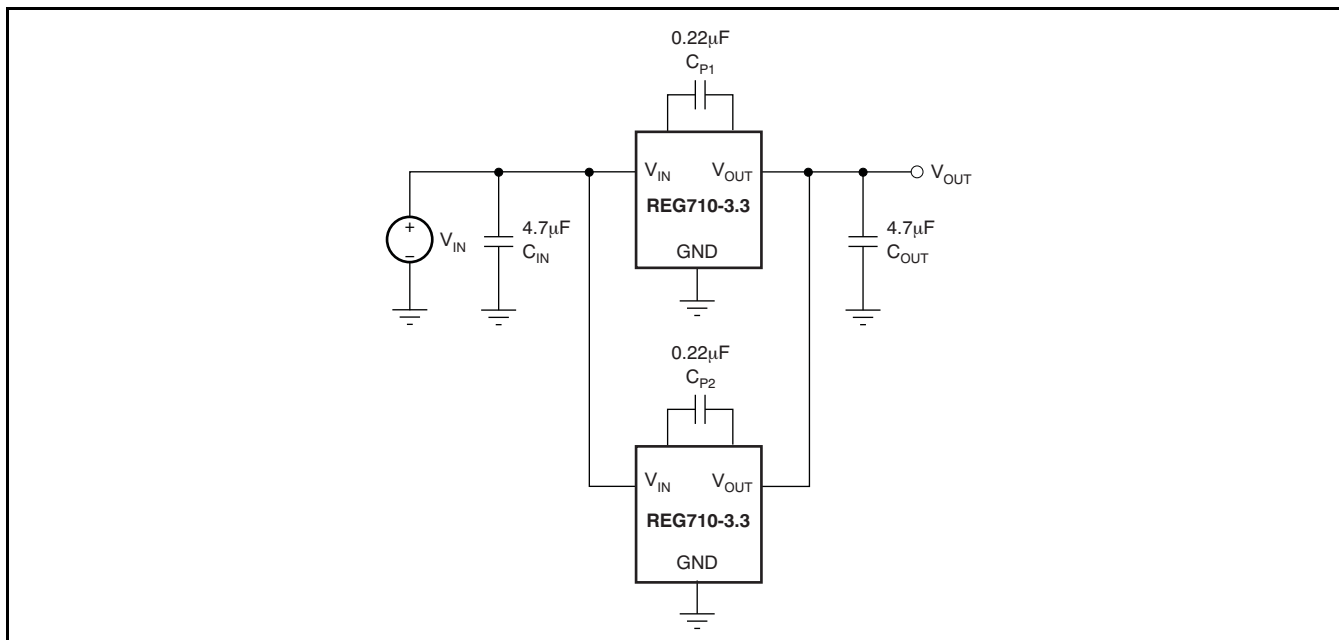

Figure 23. REG710 Circuit for Doubling the Output Current

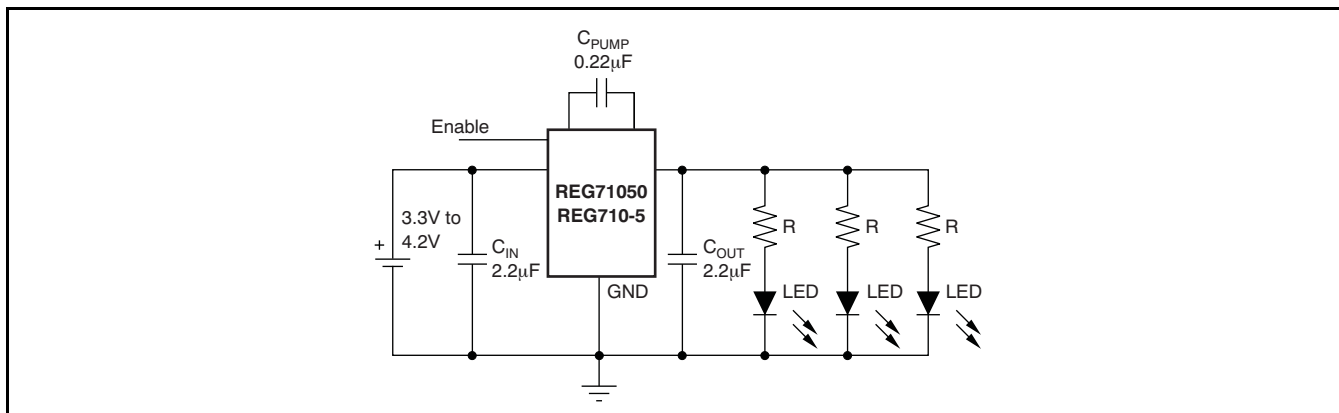

Figure 24. REG710 Circuit for Driving LEDs

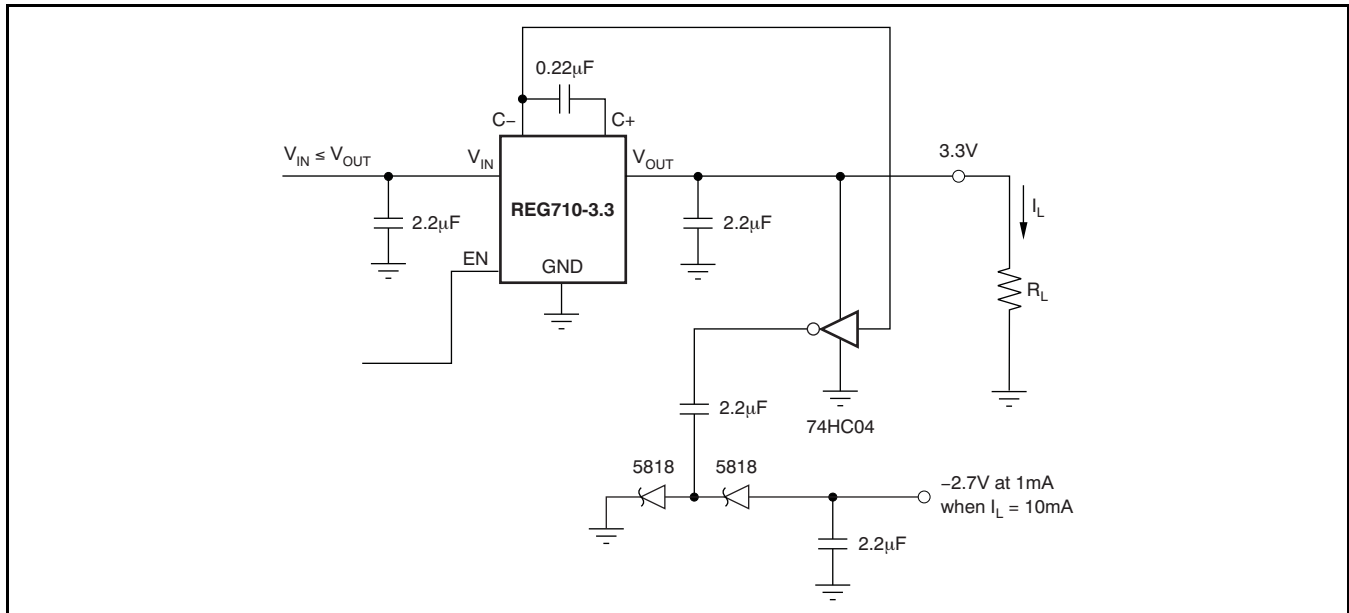

Figure 25. REG710 with Negative Bias Supply

PACKAGING INFORMATION

Orderable Device	Status ⁽¹⁾	Package Type	Package Drawing	Pins	Package Qty	Eco Plan ⁽²⁾	Lead/Ball Finish	MSL Peak Temp ⁽³⁾
REG71050DDCR	ACTIVE	SOT	DDC	6	3000	Green (RoHS & no Sb/Br)	CU NIPDAU	Level-1-260C-UNLIM
REG71050DDCRG4	ACTIVE	SOT	DDC	6	3000	Green (RoHS & no Sb/Br)	CU NIPDAU	Level-1-260C-UNLIM
REG71050DDCT	ACTIVE	SOT	DDC	6	250	Green (RoHS & no Sb/Br)	CU NIPDAU	Level-1-260C-UNLIM
REG71050DDCTG4	ACTIVE	SOT	DDC	6	250	Green (RoHS & no Sb/Br)	CU NIPDAU	Level-1-260C-UNLIM
REG71050DRVR	ACTIVE	SON	DRV	6	3000	Green (RoHS & no Sb/Br)	CU NIPDAU	Level-2-260C-1 YEAR
REG71050DRVRG4	ACTIVE	SON	DRV	6	3000	Green (RoHS & no Sb/Br)	CU NIPDAU	Level-2-260C-1 YEAR
REG71050DRVT	ACTIVE	SON	DRV	6	250	Green (RoHS & no Sb/Br)	CU NIPDAU	Level-2-260C-1 YEAR
REG71050DRVTG4	ACTIVE	SON	DRV	6	250	Green (RoHS & no Sb/Br)	CU NIPDAU	Level-2-260C-1 YEAR
REG71055DDCR	ACTIVE	SOT	DDC	6	3000	Green (RoHS & no Sb/Br)	CU NIPDAU	Level-1-260C-UNLIM
REG71055DDCRG4	ACTIVE	SOT	DDC	6	3000	Green (RoHS & no Sb/Br)	CU NIPDAU	Level-1-260C-UNLIM
REG71055DDCT	ACTIVE	SOT	DDC	6	250	Green (RoHS & no Sb/Br)	CU NIPDAU	Level-1-260C-UNLIM
REG71055DDCTG4	ACTIVE	SOT	DDC	6	250	Green (RoHS & no Sb/Br)	CU NIPDAU	Level-1-260C-UNLIM
REG710NA-2.5/250	ACTIVE	SOT-23	DBV	6	250	Green (RoHS & no Sb/Br)	CU NIPDAU	Level-1-260C-UNLIM
REG710NA-2.5/250G4	ACTIVE	SOT-23	DBV	6	250	Green (RoHS & no Sb/Br)	CU NIPDAU	Level-1-260C-UNLIM
REG710NA-2.5/3K	ACTIVE	SOT-23	DBV	6	3000	Green (RoHS & no Sb/Br)	CU NIPDAU	Level-1-260C-UNLIM
REG710NA-2.5/3KG4	ACTIVE	SOT-23	DBV	6	3000	Green (RoHS & no Sb/Br)	CU NIPDAU	Level-1-260C-UNLIM
REG710NA-2.7/250	ACTIVE	SOT-23	DBV	6	250	Green (RoHS & no Sb/Br)	CU NIPDAU	Level-1-260C-UNLIM
REG710NA-2.7/250G4	ACTIVE	SOT-23	DBV	6	250	Green (RoHS & no Sb/Br)	CU NIPDAU	Level-1-260C-UNLIM
REG710NA-3.3/250	ACTIVE	SOT-23	DBV	6	250	Green (RoHS & no Sb/Br)	CU NIPDAU	Level-1-260C-UNLIM
REG710NA-3.3/250G4	ACTIVE	SOT-23	DBV	6	250	Green (RoHS & no Sb/Br)	CU NIPDAU	Level-1-260C-UNLIM
REG710NA-3.3/3K	ACTIVE	SOT-23	DBV	6	3000	Green (RoHS & no Sb/Br)	CU NIPDAU	Level-1-260C-UNLIM
REG710NA-3.3/3KG4	ACTIVE	SOT-23	DBV	6	3000	Green (RoHS & no Sb/Br)	CU NIPDAU	Level-1-260C-UNLIM
REG710NA-3/250	ACTIVE	SOT-23	DBV	6	250	Green (RoHS & no Sb/Br)	CU NIPDAU	Level-1-260C-UNLIM
REG710NA-3/250G4	ACTIVE	SOT-23	DBV	6	250	Green (RoHS & no Sb/Br)	CU NIPDAU	Level-1-260C-UNLIM
REG710NA-3/3K	ACTIVE	SOT-23	DBV	6	3000	Green (RoHS & no Sb/Br)	CU NIPDAU	Level-1-260C-UNLIM

Orderable Device	Status ⁽¹⁾	Package Type	Package Drawing	Pins	Package Qty	Eco Plan ⁽²⁾	Lead/Ball Finish	MSL Peak Temp ⁽³⁾
REG710NA-3/3KG4	ACTIVE	SOT-23	DBV	6	3000	Green (RoHS & no Sb/Br)	CU NIPDAU	Level-1-260C-UNLIM
REG710NA-5/250	ACTIVE	SOT-23	DBV	6	250	Green (RoHS & no Sb/Br)	CU NIPDAU	Level-1-260C-UNLIM
REG710NA-5/250G4	ACTIVE	SOT-23	DBV	6	250	Green (RoHS & no Sb/Br)	CU NIPDAU	Level-1-260C-UNLIM
REG710NA-5/3K	ACTIVE	SOT-23	DBV	6	3000	Green (RoHS & no Sb/Br)	CU NIPDAU	Level-1-260C-UNLIM
REG710NA-5/3KG4	ACTIVE	SOT-23	DBV	6	3000	Green (RoHS & no Sb/Br)	CU NIPDAU	Level-1-260C-UNLIM

⁽¹⁾ The marketing status values are defined as follows:

ACTIVE: Product device recommended for new designs.

LIFEBUY: TI has announced that the device will be discontinued, and a lifetime-buy period is in effect.

NRND: Not recommended for new designs. Device is in production to support existing customers, but TI does not recommend using this part in a new design.

PREVIEW: Device has been announced but is not in production. Samples may or may not be available.

OBsolete: TI has discontinued the production of the device.

⁽²⁾ Eco Plan - The planned eco-friendly classification: Pb-Free (RoHS), Pb-Free (RoHS Exempt), or Green (RoHS & no Sb/Br) - please check <http://www.ti.com/productcontent> for the latest availability information and additional product content details.

TBD: The Pb-Free/Green conversion plan has not been defined.

Pb-Free (RoHS): TI's terms "Lead-Free" or "Pb-Free" mean semiconductor products that are compatible with the current RoHS requirements for all 6 substances, including the requirement that lead not exceed 0.1% by weight in homogeneous materials. Where designed to be soldered at high temperatures, TI Pb-Free products are suitable for use in specified lead-free processes.

Pb-Free (RoHS Exempt): This component has a RoHS exemption for either 1) lead-based flip-chip solder bumps used between the die and package, or 2) lead-based die adhesive used between the die and leadframe. The component is otherwise considered Pb-Free (RoHS compatible) as defined above.

Green (RoHS & no Sb/Br): TI defines "Green" to mean Pb-Free (RoHS compatible), and free of Bromine (Br) and Antimony (Sb) based flame retardants (Br or Sb do not exceed 0.1% by weight in homogeneous material)

⁽³⁾ MSL, Peak Temp. -- The Moisture Sensitivity Level rating according to the JEDEC industry standard classifications, and peak solder temperature.

Important Information and Disclaimer:The information provided on this page represents TI's knowledge and belief as of the date that it is provided. TI bases its knowledge and belief on information provided by third parties, and makes no representation or warranty as to the accuracy of such information. Efforts are underway to better integrate information from third parties. TI has taken and continues to take reasonable steps to provide representative and accurate information but may not have conducted destructive testing or chemical analysis on incoming materials and chemicals. TI and TI suppliers consider certain information to be proprietary, and thus CAS numbers and other limited information may not be available for release.

In no event shall TI's liability arising out of such information exceed the total purchase price of the TI part(s) at issue in this document sold by TI to Customer on an annual basis.

TAPE AND REEL INFORMATION



QUADRANT ASSIGNMENTS FOR PIN 1 ORIENTATION IN TAPE



*All dimensions are nominal

Device	Package Type	Package Drawing	Pins	SPQ	Reel Diameter (mm)	Reel Width W1 (mm)	A0 (mm)	B0 (mm)	K0 (mm)	P1 (mm)	W (mm)	Pin1 Quadrant
REG71050DDCR	SOT	DDC	6	3000	179.0	8.4	3.2	3.2	1.4	4.0	8.0	Q3
REG71050DDCT	SOT	DDC	6	250	179.0	8.4	3.2	3.2	1.4	4.0	8.0	Q3
REG71050DRVR	SON	DRV	6	3000	330.0	12.4	2.2	2.2	1.1	8.0	12.0	Q2
REG71050DRVT	SON	DRV	6	250	180.0	12.4	2.2	2.2	1.1	8.0	12.0	Q2
REG71055DDCR	SOT	DDC	6	3000	179.0	8.4	3.2	3.2	1.4	4.0	8.0	Q3
REG71055DDCT	SOT	DDC	6	250	179.0	8.4	3.2	3.2	1.4	4.0	8.0	Q3
REG710NA-2.5/250	SOT-23	DBV	6	250	179.0	8.4	3.2	3.2	1.4	4.0	8.0	Q3
REG710NA-2.5/3K	SOT-23	DBV	6	3000	179.0	8.4	3.2	3.2	1.4	4.0	8.0	Q3
REG710NA-2.7/250	SOT-23	DBV	6	250	179.0	8.4	3.2	3.2	1.4	4.0	8.0	Q3
REG710NA-3.3/250	SOT-23	DBV	6	250	179.0	8.4	3.2	3.2	1.4	4.0	8.0	Q3
REG710NA-3.3/3K	SOT-23	DBV	6	3000	179.0	8.4	3.2	3.2	1.4	4.0	8.0	Q3
REG710NA-3/250	SOT-23	DBV	6	250	179.0	8.4	3.2	3.2	1.4	4.0	8.0	Q3
REG710NA-3/3K	SOT-23	DBV	6	3000	179.0	8.4	3.2	3.2	1.4	4.0	8.0	Q3
REG710NA-5/250	SOT-23	DBV	6	250	179.0	8.4	3.2	3.2	1.4	4.0	8.0	Q3
REG710NA-5/3K	SOT-23	DBV	6	3000	179.0	8.4	3.2	3.2	1.4	4.0	8.0	Q3

TAPE AND REEL BOX DIMENSIONS

*All dimensions are nominal

Device	Package Type	Package Drawing	Pins	SPQ	Length (mm)	Width (mm)	Height (mm)
REG71050DDCR	SOT	DDC	6	3000	195.0	200.0	45.0
REG71050DDCT	SOT	DDC	6	250	195.0	200.0	45.0
REG71050DRVR	SON	DRV	6	3000	346.0	346.0	29.0
REG71050DRVT	SON	DRV	6	250	190.5	212.7	31.8
REG71055DDCR	SOT	DDC	6	3000	195.0	200.0	45.0
REG71055DDCT	SOT	DDC	6	250	195.0	200.0	45.0
REG710NA-2.5/250	SOT-23	DBV	6	250	195.0	200.0	45.0
REG710NA-2.5/3K	SOT-23	DBV	6	3000	195.0	200.0	45.0
REG710NA-2.7/250	SOT-23	DBV	6	250	195.0	200.0	45.0
REG710NA-3.3/250	SOT-23	DBV	6	250	195.0	200.0	45.0
REG710NA-3.3/3K	SOT-23	DBV	6	3000	195.0	200.0	45.0
REG710NA-3/250	SOT-23	DBV	6	250	195.0	200.0	45.0
REG710NA-3/3K	SOT-23	DBV	6	3000	195.0	200.0	45.0
REG710NA-5/250	SOT-23	DBV	6	250	195.0	200.0	45.0
REG710NA-5/3K	SOT-23	DBV	6	3000	195.0	200.0	45.0

DBV (R-PDSO-G6)

PLASTIC SMALL-OUTLINE PACKAGE

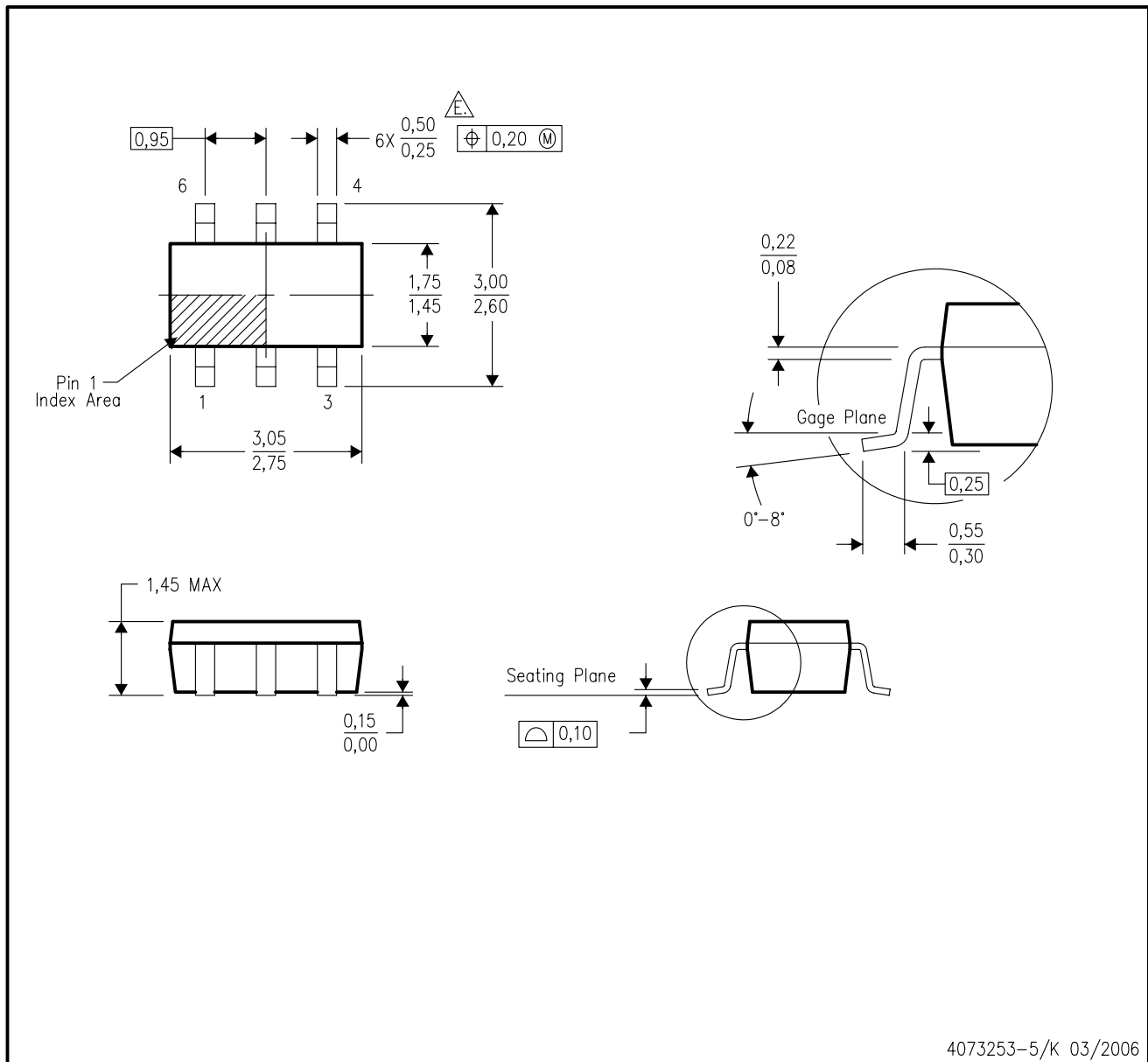

- NOTES:
- A. All linear dimensions are in millimeters.
 - B. This drawing is subject to change without notice.
 - C. Body dimensions do not include mold flash or protrusion. Mold flash and protrusion shall not exceed 0.15 per side.
 - D. Leads 1,2,3 may be wider than leads 4,5,6 for package orientation.
- \triangle Falls within JEDEC MO-178 Variation AB, except minimum lead width.

DRV (S-PDSO-N6)

PLASTIC SMALL OUTLINE

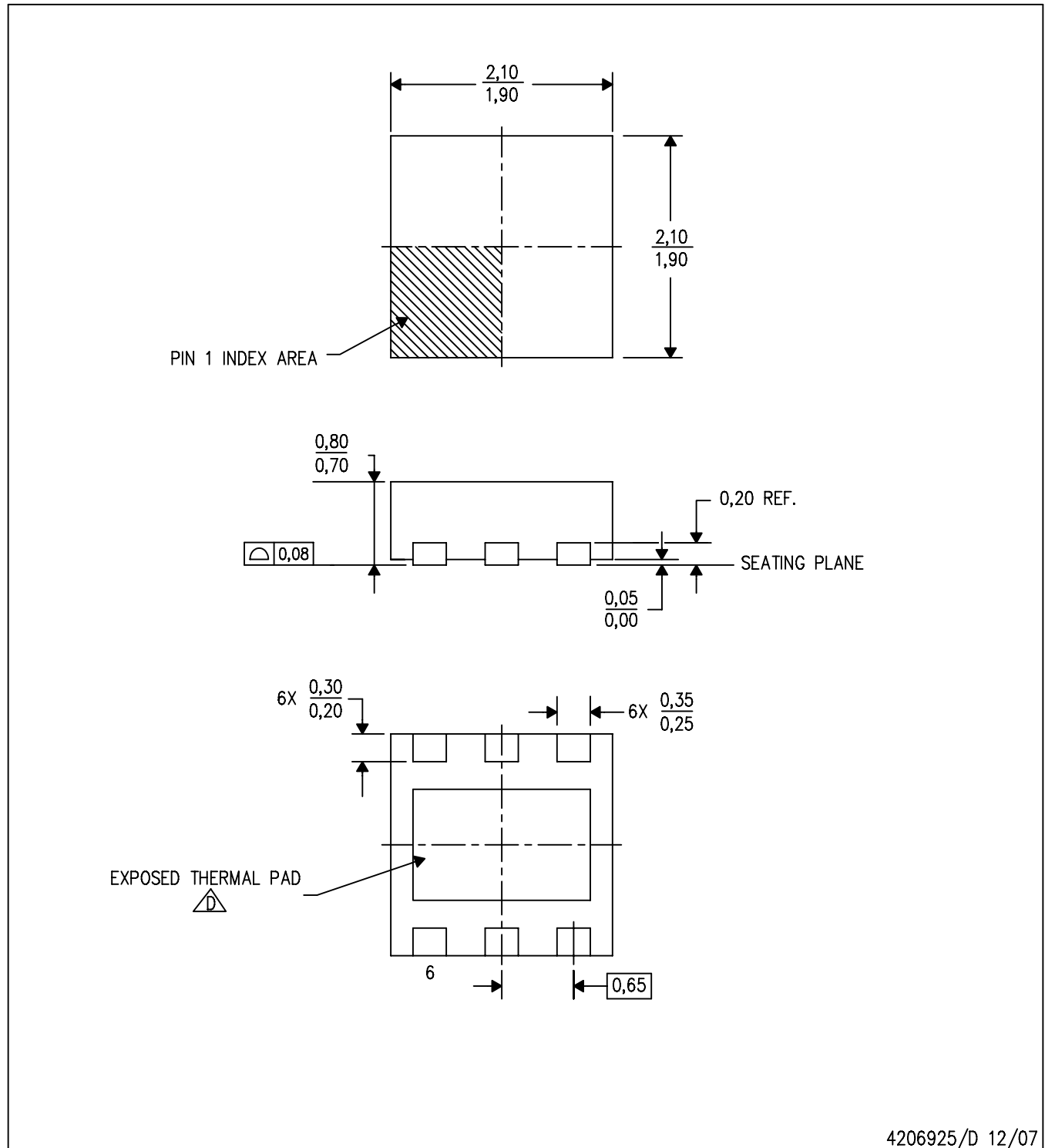

4206925/D 12/07

- NOTES:
- A. All linear dimensions are in millimeters. Dimensioning and tolerancing per ASME Y14.5M-1994.
 - B. This drawing is subject to change without notice.
 - C. Small Outline No-Lead (SON) package configuration.
-  The package thermal pad must be soldered to the board for thermal and mechanical performance. See the Product Data Sheet for details regarding the exposed thermal pad dimensions.

THERMAL INFORMATION

This package incorporates an exposed thermal pad that is designed to be attached directly to an external heatsink. The thermal pad must be soldered directly to the printed circuit board (PCB). After soldering, the PCB can be used as a heatsink. In addition, through the use of thermal vias, the thermal pad can be attached directly to the appropriate copper plane shown in the electrical schematic for the device, or alternatively, can be attached to a special heatsink structure designed into the PCB. This design optimizes the heat transfer from the integrated circuit (IC).

For information on the Quad Flatpack No-Lead (QFN) package and its advantages, refer to Application Report, Quad Flatpack No-Lead Logic Packages, Texas Instruments Literature No. SCBA017. This document is available at www.ti.com.

The exposed thermal pad dimensions for this package are shown in the following illustration.

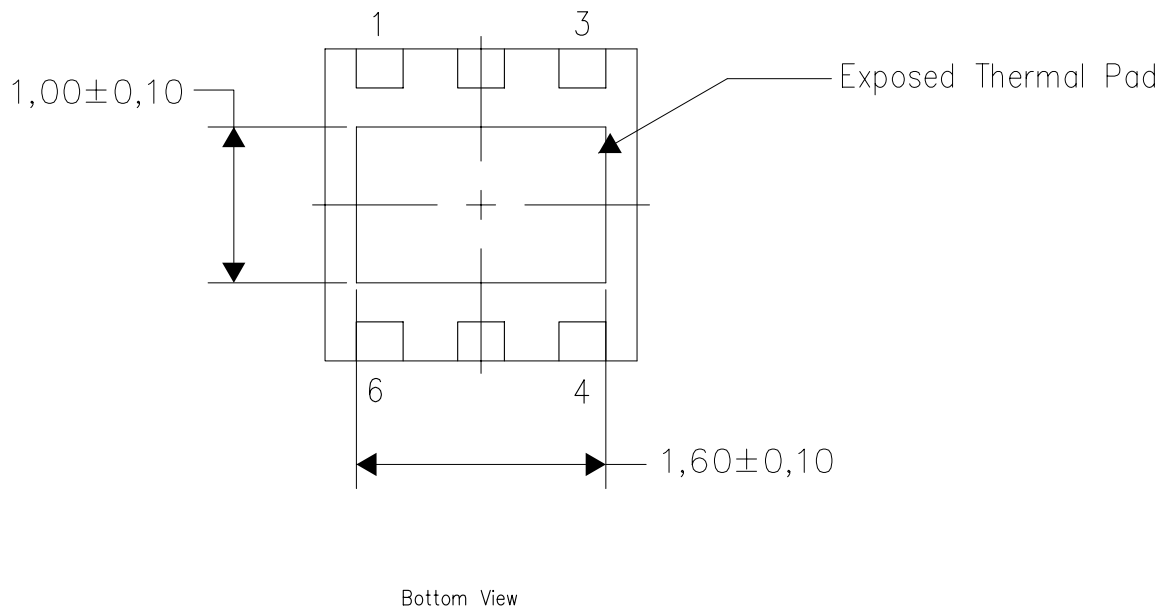

NOTE: All linear dimensions are in millimeters

Exposed Thermal Pad Dimensions

DRV (S-PDSO-N6)

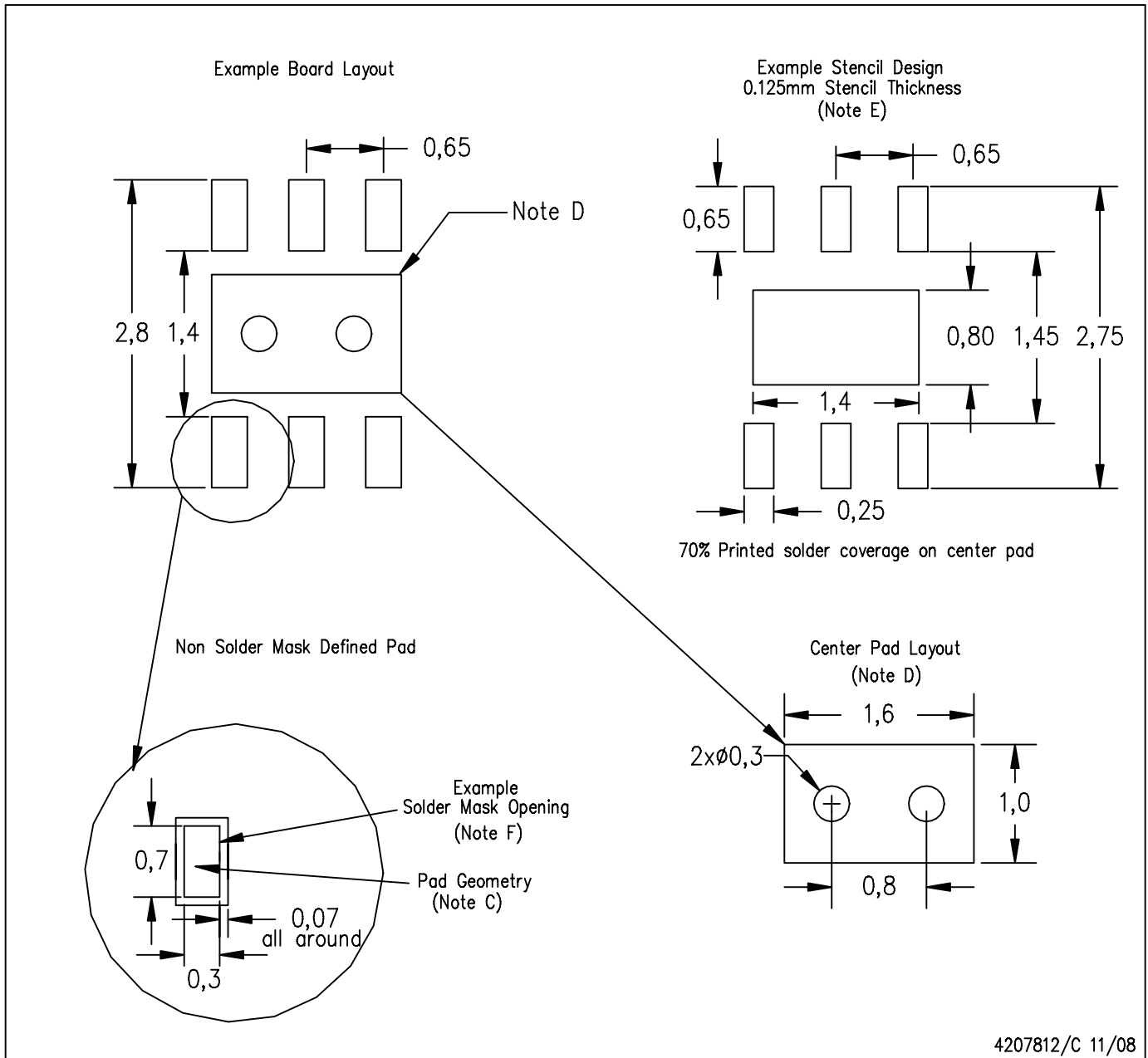

- NOTES:
- All linear dimensions are in millimeters.
 - This drawing is subject to change without notice.
 - Publication IPC-7351 is recommended for alternate designs.
 - This package is designed to be soldered to a thermal pad on the board. Refer to Application Note, QFN Packages, Texas Instruments Literature No. SCBA017, SLUA271, and also the Product Data Sheets for specific thermal information, via requirements, and recommended board layout. These documents are available at www.ti.com <<http://www.ti.com>>.
 - Laser cutting apertures with trapezoidal walls and also rounding corners will offer better paste release. Customers should contact their board assembly site for stencil design recommendations. Refer to IPC 7525 for stencil design considerations.
 - Customers should contact their board fabrication site for solder mask tolerances.

DDC (R-PDSO-G6)

PLASTIC SMALL-OUTLINE

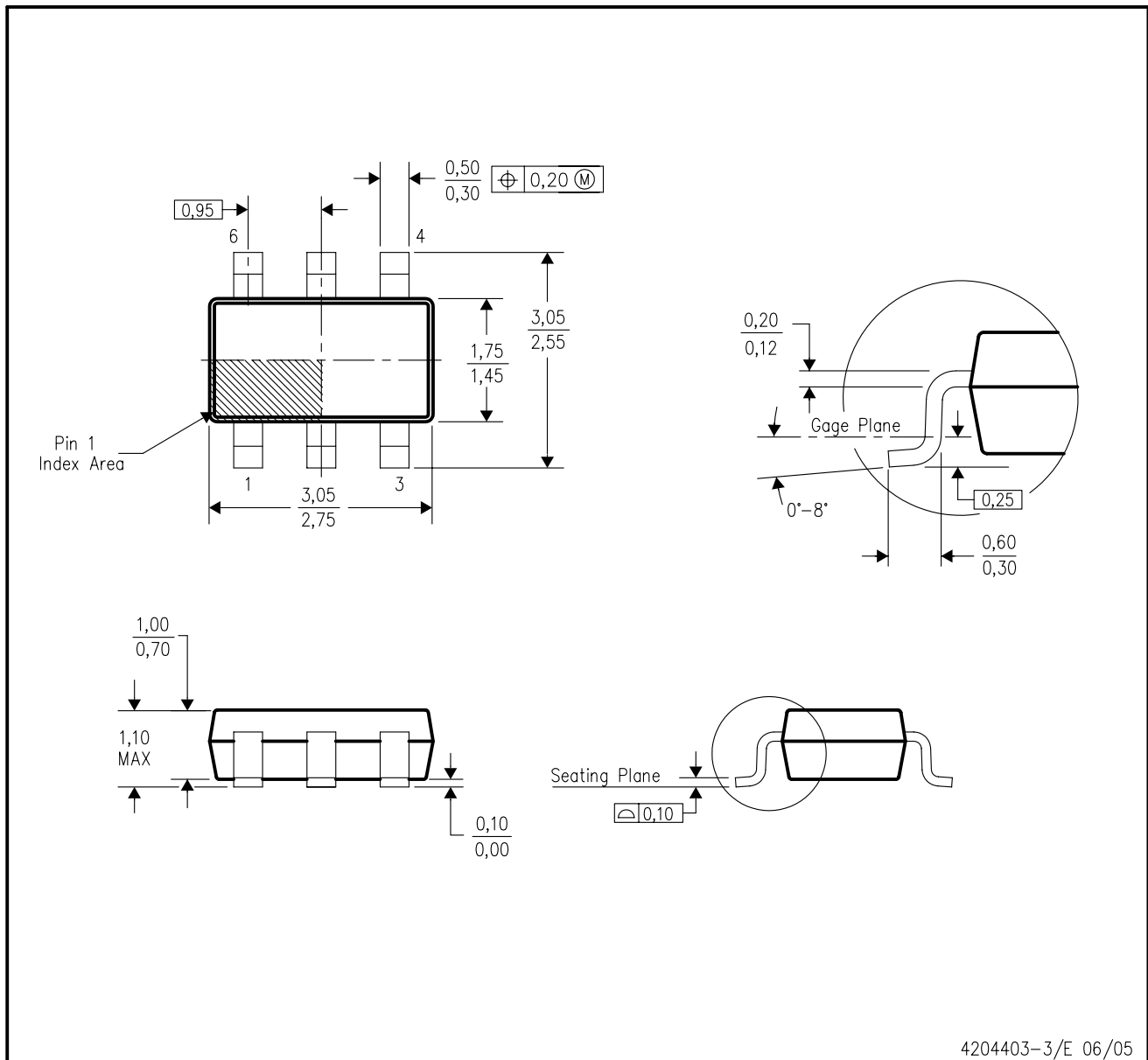

- NOTES:
- All linear dimensions are in millimeters.
 - This drawing is subject to change without notice.
 - Body dimensions do not include mold flash or protrusion.
 - Falls within JEDEC MO-193 variation AA (6 pin).

IMPORTANT NOTICE

Texas Instruments Incorporated and its subsidiaries (TI) reserve the right to make corrections, modifications, enhancements, improvements, and other changes to its products and services at any time and to discontinue any product or service without notice. Customers should obtain the latest relevant information before placing orders and should verify that such information is current and complete. All products are sold subject to TI's terms and conditions of sale supplied at the time of order acknowledgment.

TI warrants performance of its hardware products to the specifications applicable at the time of sale in accordance with TI's standard warranty. Testing and other quality control techniques are used to the extent TI deems necessary to support this warranty. Except where mandated by government requirements, testing of all parameters of each product is not necessarily performed.

TI assumes no liability for applications assistance or customer product design. Customers are responsible for their products and applications using TI components. To minimize the risks associated with customer products and applications, customers should provide adequate design and operating safeguards.

TI does not warrant or represent that any license, either express or implied, is granted under any TI patent right, copyright, mask work right, or other TI intellectual property right relating to any combination, machine, or process in which TI products or services are used. Information published by TI regarding third-party products or services does not constitute a license from TI to use such products or services or a warranty or endorsement thereof. Use of such information may require a license from a third party under the patents or other intellectual property of the third party, or a license from TI under the patents or other intellectual property of TI.

Reproduction of TI information in TI data books or data sheets is permissible only if reproduction is without alteration and is accompanied by all associated warranties, conditions, limitations, and notices. Reproduction of this information with alteration is an unfair and deceptive business practice. TI is not responsible or liable for such altered documentation. Information of third parties may be subject to additional restrictions.

Resale of TI products or services with statements different from or beyond the parameters stated by TI for that product or service voids all express and any implied warranties for the associated TI product or service and is an unfair and deceptive business practice. TI is not responsible or liable for any such statements.

TI products are not authorized for use in safety-critical applications (such as life support) where a failure of the TI product would reasonably be expected to cause severe personal injury or death, unless officers of the parties have executed an agreement specifically governing such use. Buyers represent that they have all necessary expertise in the safety and regulatory ramifications of their applications, and acknowledge and agree that they are solely responsible for all legal, regulatory and safety-related requirements concerning their products and any use of TI products in such safety-critical applications, notwithstanding any applications-related information or support that may be provided by TI. Further, Buyers must fully indemnify TI and its representatives against any damages arising out of the use of TI products in such safety-critical applications.

TI products are neither designed nor intended for use in military/aerospace applications or environments unless the TI products are specifically designated by TI as military-grade or "enhanced plastic." Only products designated by TI as military-grade meet military specifications. Buyers acknowledge and agree that any such use of TI products which TI has not designated as military-grade is solely at the Buyer's risk, and that they are solely responsible for compliance with all legal and regulatory requirements in connection with such use.

TI products are neither designed nor intended for use in automotive applications or environments unless the specific TI products are designated by TI as compliant with ISO/TS 16949 requirements. Buyers acknowledge and agree that, if they use any non-designated products in automotive applications, TI will not be responsible for any failure to meet such requirements.

Following are URLs where you can obtain information on other Texas Instruments products and application solutions:

Products

Amplifiers	amplifier.ti.com
Data Converters	dataconverter.ti.com
DLP® Products	www.dlp.com
DSP	dsp.ti.com
Clocks and Timers	www.ti.com/clocks
Interface	interface.ti.com
Logic	logic.ti.com
Power Mgmt	power.ti.com
Microcontrollers	microcontroller.ti.com
RFID	www.ti-rfid.com
RF/IF and ZigBee® Solutions	www.ti.com/lprf

Applications

Audio	www.ti.com/audio
Automotive	www.ti.com/automotive
Broadband	www.ti.com/broadband
Digital Control	www.ti.com/digitalcontrol
Medical	www.ti.com/medical
Military	www.ti.com/military
Optical Networking	www.ti.com/opticalnetwork
Security	www.ti.com/security
Telephony	www.ti.com/telephony
Video & Imaging	www.ti.com/video
Wireless	www.ti.com/wireless

Mailing Address: Texas Instruments, Post Office Box 655303, Dallas, Texas 75265
Copyright © 2009, Texas Instruments Incorporated