

# SN54ACT240, SN74ACT240 OCTAL BUFFERS/DRIVERS WITH 3-STATE OUTPUTS

SCAS515C – JUNE 1995 – REVISED OCTOBER 2002

- 4.5-V to 5.5-V  $V_{CC}$  Operation
- Inputs Accept Voltages to 5.5 V
- Max  $t_{pd}$  of 8.5 ns at 5 V
- Inputs Are TTL Compatible

SN54ACT240 . . . J OR W PACKAGE  
SN74ACT240 . . . DB, DW, N, NS, OR PW PACKAGE  
(TOP VIEW)

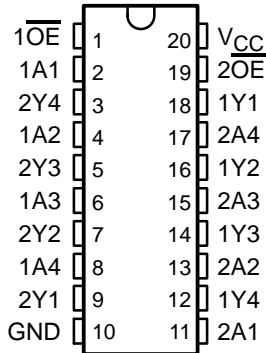

SN54ACT240 . . . FK PACKAGE  
(TOP VIEW)

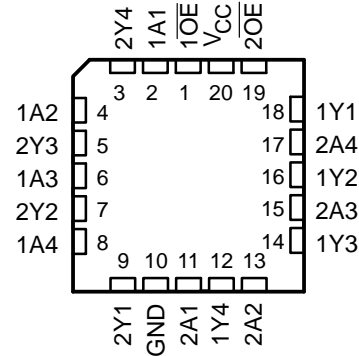

## description/ordering information

These octal buffers and line drivers are designed specifically to improve the performance and density of 3-state memory address drivers, clock drivers, and bus-oriented receivers and transmitters.

The 'ACT240 devices are organized as two 4-bit buffers/drivers with separate output-enable ( $\overline{OE}$ ) inputs. When  $\overline{OE}$  is low, the device passes inverted data from the A inputs to the Y outputs. When  $\overline{OE}$  is high, the outputs are in the high-impedance state.

To ensure the high-impedance state during power up or power down,  $\overline{OE}$  should be tied to  $V_{CC}$  through a pullup resistor; the minimum value of the resistor is determined by the current-sinking capability of the driver.

## ORDERING INFORMATION

| TA             | PACKAGE†   |               | ORDERABLE PART NUMBER | TOP-SIDE MARKING |
|----------------|------------|---------------|-----------------------|------------------|
| -40°C to 85°C  | PDIP – N   | Tube          | SN74ACT240N           | SN74ACT240N      |
|                | SOIC – DW  | Tube          | SN74ACT240DW          | ACT240           |
|                |            | Tape and reel | SN74ACT240DWR         |                  |
|                |            | SOP – NS      | Tape and reel         |                  |
|                | SSOP – DB  | Tape and reel | SN74ACT240DBR         | AD240            |
|                | TSSOP – PW | Tape and reel | SN74ACT240PWR         | AD240            |
| -55°C to 125°C | CDIP – J   | Tube          | SNJ54ACT240J          | SNJ54ACT240J     |
|                | CFP – W    | Tube          | SNJ54ACT240W          | SNJ54ACT240W     |
|                | LCCC – FK  | Tube          | SNJ54ACT240FK         | SNJ54ACT240FK    |

† Package drawings, standard packing quantities, thermal data, symbolization, and PCB design guidelines are available at [www.ti.com/sc/package](http://www.ti.com/sc/package).



Please be aware that an important notice concerning availability, standard warranty, and use in critical applications of Texas Instruments semiconductor products and disclaimers thereto appears at the end of this data sheet.

PRODUCTION DATA information is current as of publication date. Products conform to specifications per the terms of Texas Instruments standard warranty. Production processing does not necessarily include testing of all parameters.

 **TEXAS  
INSTRUMENTS**

POST OFFICE BOX 655303 • DALLAS, TEXAS 75265

Copyright © 2002, Texas Instruments Incorporated  
On products compliant to MIL-PRF-38535, all parameters are tested unless otherwise noted. On all other products, production processing does not necessarily include testing of all parameters.

# SN54ACT240, SN74ACT240 OCTAL BUFFERS/DRIVERS WITH 3-STATE OUTPUTS

SCAS515C – JUNE 1995 – REVISED OCTOBER 2002

FUNCTION TABLE  
(each buffer)

| INPUTS          |   | OUTPUT |
|-----------------|---|--------|
| $\overline{OE}$ | A | Y      |
| L               | H | L      |
| L               | L | H      |
| H               | X | Z      |

## logic diagram (positive logic)

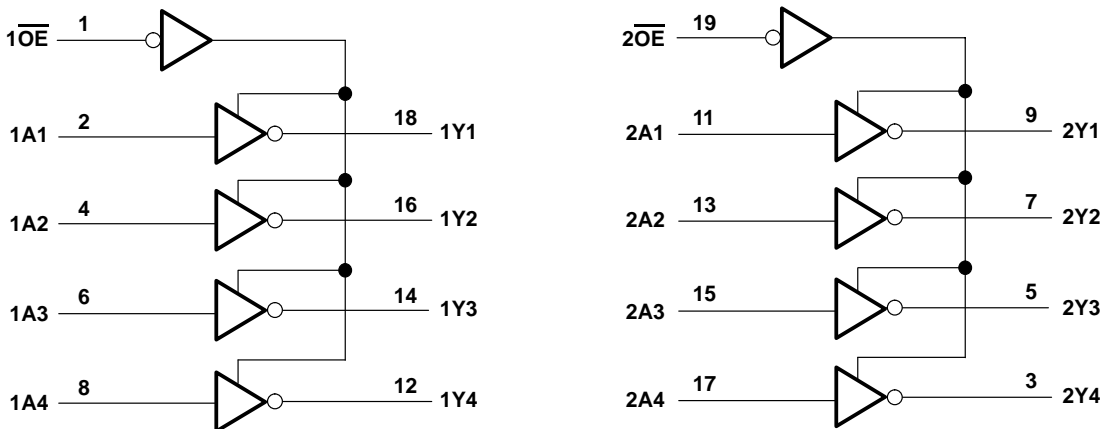

## absolute maximum ratings over operating free-air temperature range (unless otherwise noted)†

|  |                            |
|--|----------------------------|
| Supply voltage range, $V_{CC}$                                 | -0.5 V to 7 V              |
| Input voltage range, $V_I$ (see Note 1)                        | -0.5 V to $V_{CC} + 0.5$ V |
| Output voltage range, $V_O$ (see Note 1)                       | -0.5 V to $V_{CC} + 0.5$ V |
| Input clamp current, $I_{IK}$ ( $V_I < 0$ or $V_I > V_{CC}$ )  | $\pm 20$ mA                |
| Output clamp current, $I_{OK}$ ( $V_O < 0$ or $V_O > V_{CC}$ ) | $\pm 20$ mA                |
| Continuous output current, $I_O$ ( $V_O = 0$ to $V_{CC}$ )     | $\pm 50$ mA                |
| Continuous current through $V_{CC}$ or GND                     | $\pm 200$ mA               |
| Package thermal impedance, $\theta_{JA}$ (see Note 2):         |                            |
| DB package   | 70°C/W                     |
| DW package   | 58°C/W                     |
| N package  | 69°C/W                     |
| NS package   | 60°C/W                     |
| PW package   | 83°C/W                     |
| Storage temperature range, $T_{stg}$                           | -65°C to 150°C             |

† Stresses beyond those listed under “absolute maximum ratings” may cause permanent damage to the device. These are stress ratings only, and functional operation of the device at these or any other conditions beyond those indicated under “recommended operating conditions” is not implied. Exposure to absolute-maximum-rated conditions for extended periods may affect device reliability.

- NOTES: 1. The input and output voltage ratings may be exceeded if the input and output current ratings are observed.  
2. The package thermal impedance is calculated in accordance with JESD 51-7.

# SN54ACT240, SN74ACT240 OCTAL BUFFERS/DRIVERS WITH 3-STATE OUTPUTS

SCAS515C – JUNE 1995 – REVISED OCTOBER 2002

## recommended operating conditions (see Note 3)

|                 |                                    | SN54ACT240 |                 | SN74ACT240 |                 | UNIT |
|-----------------|------------------------------------|------------|-----------------|------------|-----------------|------|
|                 |                                    | MIN        | MAX             | MIN        | MAX             |      |
| V <sub>CC</sub> | Supply voltage                     | 4.5        | 5.5             | 4.5        | 5.5             | V    |
| V <sub>IH</sub> | High-level input voltage           | 2          |                 | 2          |                 | V    |
| V <sub>IL</sub> | Low-level input voltage            |            | 0.8             |            | 0.8             | V    |
| V <sub>I</sub>  | Input voltage                      | 0          | V <sub>CC</sub> | 0          | V <sub>CC</sub> | V    |
| V <sub>O</sub>  | Output voltage                     | 0          | V <sub>CC</sub> | 0          | V <sub>CC</sub> | V    |
| I <sub>OH</sub> | High-level output current          |            | -24             |            | -24             | mA   |
| I <sub>OL</sub> | Low-level output current           |            | 24              |            | 24              | mA   |
| Δt/Δv           | Input transition rise or fall rate |            | 8               |            | 8               | ns/V |
| T <sub>A</sub>  | Operating free-air temperature     | -55        | 125             | -40        | 85              | °C   |

NOTE 3: All unused inputs of the device must be held at V<sub>CC</sub> or GND to ensure proper device operation. Refer to the TI application report, *Implications of Slow or Floating CMOS Inputs*, literature number SCBA004.

## electrical characteristics over recommended operating free-air temperature range (unless otherwise noted)

| PARAMETER                             | TEST CONDITIONS   | V <sub>CC</sub> | T <sub>A</sub> = 25°C |       |       | SN54ACT240 |      | SN74ACT240 |     | UNIT |
|---------------------------------------|---|-----------------|-----------------------|-------|-------|------------|------|------------|-----|------|
|                                       |   |                 | MIN                   | TYP   | MAX   | MIN        | MAX  | MIN        | MAX |      |
| V <sub>OH</sub>                       | I <sub>OH</sub> = -50 μA                                    | 4.5 V           | 4.4                   | 4.49  |       | 4.4        |      | 4.4        | V   |      |
|                                       |   | 5.5 V           | 5.4                   | 5.49  |       | 5.4        |      | 5.4        |     |      |
|                                       | I <sub>OH</sub> = -24 mA                                    | 4.5 V           | 3.86                  |       |       | 3.7        |      | 3.76       |     |      |
|                                       |   | 5.5 V           | 4.86                  |       |       | 4.7        |      | 4.76       |     |      |
|                                       | I <sub>OH</sub> = -50 mA <sup>†</sup>                       | 5.5 V           |                       |       |       | 3.85       |      |            |     |      |
| I <sub>OH</sub> = -75 mA <sup>†</sup> | 5.5 V   |                 |                       |       |       |            | 3.85 |            |     |      |
| V <sub>OL</sub>                       | I <sub>OL</sub> = 50 μA                                     | 4.5 V           |                       | 0.001 | 0.1   |            | 0.1  | 0.1        | V   |      |
|                                       |   | 5.5 V           |                       | 0.001 | 0.1   |            | 0.1  | 0.1        |     |      |
|                                       | I <sub>OL</sub> = 24 mA                                     | 4.5 V           |                       |       | 0.36  |            | 0.5  | 0.44       |     |      |
|                                       |   | 5.5 V           |                       |       | 0.36  |            | 0.5  | 0.44       |     |      |
|                                       | I <sub>OL</sub> = 50 mA <sup>†</sup>                        | 5.5 V           |                       |       |       | 1.65       |      |            |     |      |
| I <sub>OL</sub> = 75 mA <sup>†</sup>  | 5.5 V   |                 |                       |       |       |            | 1.65 |            |     |      |
| I <sub>OZ</sub>                       | V <sub>O</sub> = V <sub>CC</sub> or GND                     | 5.5 V           |                       |       | ±0.25 |            | ±5   | ±2.5       | μA  |      |
| I <sub>I</sub>                        | V <sub>I</sub> = V <sub>CC</sub> or GND                     | 5.5 V           |                       |       | ±0.1  |            | ±1   | ±1         | μA  |      |
| I <sub>CC</sub>                       | V <sub>I</sub> = V <sub>CC</sub> or GND, I <sub>O</sub> = 0 | 5.5 V           |                       |       | 4     |            | 80   | 40         | μA  |      |
| ΔI <sub>CC</sub> <sup>‡</sup>         | One input at 3.4 V, Other inputs at GND or V <sub>CC</sub>  | 5.5 V           |                       | 0.6   |       | 1.6        |      | 1.5        | mA  |      |
| C <sub>i</sub>                        | V <sub>I</sub> = V <sub>CC</sub> or GND                     | 5 V             |                       | 2.5   |       |            |      |            | pF  |      |
| C <sub>o</sub>                        | V <sub>I</sub> = V <sub>CC</sub> or GND                     | 5 V             |                       | 8     |       |            |      |            | pF  |      |

<sup>†</sup> Not more than one output should be tested at a time, and the duration of the test should not exceed 2 ms.

<sup>‡</sup> This is the increase in supply current for each input that is at one of the specified TTL voltage levels, rather than 0 V or V<sub>CC</sub>.

# SN54ACT240, SN74ACT240 OCTAL BUFFERS/DRIVERS WITH 3-STATE OUTPUTS

SCAS515C – JUNE 1995 – REVISED OCTOBER 2002

switching characteristics over recommended operating free-air temperature range,  $V_{CC} = 5\text{ V} \pm 0.5\text{ V}$  (unless otherwise noted) (see Figure 1)

| PARAMETER | FROM (INPUT)    | TO (OUTPUT) | $T_A = 25^\circ\text{C}$ |     | SN54ACT240 |     | SN74ACT240 |     | UNIT |     |
|-----------|-----------------|-------------|--------------------------|-----|------------|-----|------------|-----|------|-----|
|           |                 |             | MIN                      | TYP | MAX        | MIN | MAX        | MIN |      | MAX |
| $t_{PLH}$ | A               | Y           | 1.5                      | 6   | 8.5        | 1   | 9.5        | 1.5 | 9.5  | ns  |
| $t_{PHL}$ |                 |             | 1.5                      | 5.5 | 7.5        | 1   | 9          | 1.5 | 8.5  |     |
| $t_{PZH}$ | $\overline{OE}$ | Y           | 1.5                      | 7   | 8.5        | 1   | 10         | 1   | 9.5  | ns  |
| $t_{PZL}$ |                 |             | 2                        | 7   | 9.5        | 1   | 11.5       | 1.5 | 10.5 |     |
| $t_{PHZ}$ | $\overline{OE}$ | Y           | 2                        | 8   | 9.5        | 1   | 11         | 2   | 10.5 | ns  |
| $t_{PLZ}$ |                 |             | 2.5                      | 6.5 | 10         | 1   | 11.5       | 2   | 10.5 |     |

operating characteristics,  $V_{CC} = 5\text{ V}$ ,  $T_A = 25^\circ\text{C}$

| PARAMETER  | TEST CONDITIONS                           | TYP | UNIT |
|--|---|-----|------|
| $C_{pd}$ Power dissipation capacitance per buffer/driver | $C_L = 50\text{ pF}$ , $f = 1\text{ MHz}$ | 45  | pF   |

## PARAMETER MEASUREMENT INFORMATION

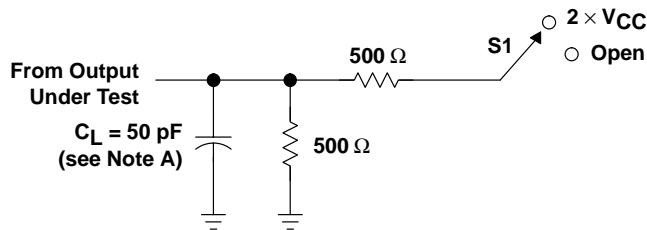

| TEST              | S1                |
|-------------------|-------------------|
| $t_{PLH}/t_{PHL}$ | Open              |
| $t_{PLZ}/t_{PZL}$ | $2 \times V_{CC}$ |
| $t_{PHZ}/t_{PZH}$ | Open              |

LOAD CIRCUIT

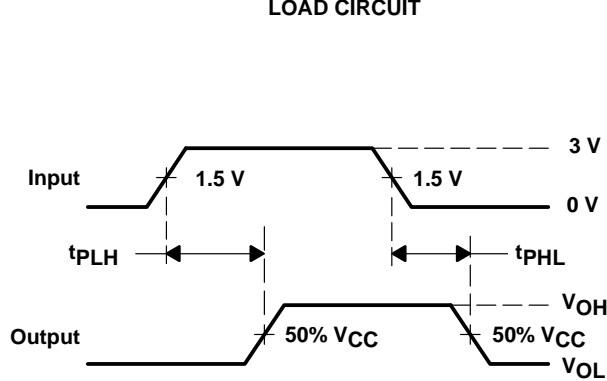

VOLTAGE WAVEFORMS

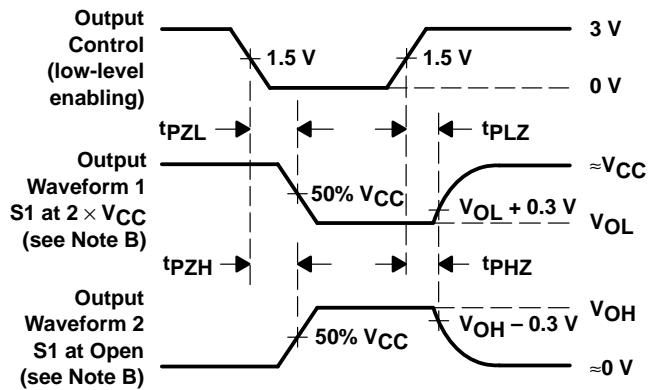

VOLTAGE WAVEFORMS

- NOTES: A.  $C_L$  includes probe and jig capacitance.  
 B. Waveform 1 is for an output with internal conditions such that the output is low except when disabled by the output control. Waveform 2 is for an output with internal conditions such that the output is high except when disabled by the output control.  
 C. All input pulses are supplied by generators having the following characteristics:  $PRR \leq 1\text{ MHz}$ ,  $Z_O = 50\ \Omega$ ,  $t_r \leq 2.5\text{ ns}$ ,  $t_f \leq 2.5\text{ ns}$ .  
 D. The outputs are measured one at a time with one input transition per measurement.

Figure 1. Load Circuit and Voltage Waveforms

**PACKAGING INFORMATION**

| Orderable Device | Status <sup>(1)</sup> | Package Type | Package Drawing | Pins | Package Qty | Eco Plan <sup>(2)</sup> | Lead/Ball Finish | MSL Peak Temp <sup>(3)</sup> |
|------------------|-----------------------|--------------|-----------------|------|-------------|-------------------------|------------------|------------------------------|
| 5962-8775901M2A  | ACTIVE                | LCCC         | FK              | 20   | 1           | TBD                     | POST-PLATE       | N / A for Pkg Type           |
| 5962-8775901MRA  | ACTIVE                | CDIP         | J               | 20   | 1           | TBD                     | A42 SNPB         | N / A for Pkg Type           |
| 5962-8775901MSA  | ACTIVE                | CFP          | W               | 20   | 1           | TBD                     | A42              | N / A for Pkg Type           |
| SN74ACT240DBLE   | OBSOLETE              | SSOP         | DB              | 20   |             | TBD                     | Call TI          | Call TI                      |
| SN74ACT240DBR    | ACTIVE                | SSOP         | DB              | 20   | 2000        | Green (RoHS & no Sb/Br) | CU NIPDAU        | Level-1-260C-UNLIM           |
| SN74ACT240DBRE4  | ACTIVE                | SSOP         | DB              | 20   | 2000        | Green (RoHS & no Sb/Br) | CU NIPDAU        | Level-1-260C-UNLIM           |
| SN74ACT240DW     | ACTIVE                | SOIC         | DW              | 20   | 25          | Green (RoHS & no Sb/Br) | CU NIPDAU        | Level-1-260C-UNLIM           |
| SN74ACT240DWE4   | ACTIVE                | SOIC         | DW              | 20   | 25          | Green (RoHS & no Sb/Br) | CU NIPDAU        | Level-1-260C-UNLIM           |
| SN74ACT240DWR    | ACTIVE                | SOIC         | DW              | 20   | 2000        | Green (RoHS & no Sb/Br) | CU NIPDAU        | Level-1-260C-UNLIM           |
| SN74ACT240DWRE4  | ACTIVE                | SOIC         | DW              | 20   | 2000        | Green (RoHS & no Sb/Br) | CU NIPDAU        | Level-1-260C-UNLIM           |
| SN74ACT240N      | ACTIVE                | PDIP         | N               | 20   | 20          | Pb-Free (RoHS)          | CU NIPDAU        | N / A for Pkg Type           |
| SN74ACT240NE4    | ACTIVE                | PDIP         | N               | 20   | 20          | Pb-Free (RoHS)          | CU NIPDAU        | N / A for Pkg Type           |
| SN74ACT240NSR    | ACTIVE                | SO           | NS              | 20   | 2000        | Green (RoHS & no Sb/Br) | CU NIPDAU        | Level-1-260C-UNLIM           |
| SN74ACT240NSRE4  | ACTIVE                | SO           | NS              | 20   | 2000        | Green (RoHS & no Sb/Br) | CU NIPDAU        | Level-1-260C-UNLIM           |
| SN74ACT240PW     | ACTIVE                | TSSOP        | PW              | 20   | 70          | Green (RoHS & no Sb/Br) | CU NIPDAU        | Level-1-260C-UNLIM           |
| SN74ACT240PWE4   | ACTIVE                | TSSOP        | PW              | 20   | 70          | Green (RoHS & no Sb/Br) | CU NIPDAU        | Level-1-260C-UNLIM           |
| SN74ACT240PWG4   | ACTIVE                | TSSOP        | PW              | 20   | 70          | Green (RoHS & no Sb/Br) | CU NIPDAU        | Level-1-260C-UNLIM           |
| SN74ACT240PWLE   | OBSOLETE              | TSSOP        | PW              | 20   |             | TBD                     | Call TI          | Call TI                      |
| SN74ACT240PWR    | ACTIVE                | TSSOP        | PW              | 20   | 2000        | Green (RoHS & no Sb/Br) | CU NIPDAU        | Level-1-260C-UNLIM           |
| SN74ACT240PWRE4  | ACTIVE                | TSSOP        | PW              | 20   | 2000        | Green (RoHS & no Sb/Br) | CU NIPDAU        | Level-1-260C-UNLIM           |
| SN74ACT240PWRG4  | ACTIVE                | TSSOP        | PW              | 20   | 2000        | Green (RoHS & no Sb/Br) | CU NIPDAU        | Level-1-260C-UNLIM           |
| SNJ54ACT240FK    | ACTIVE                | LCCC         | FK              | 20   | 1           | TBD                     | POST-PLATE       | N / A for Pkg Type           |
| SNJ54ACT240J     | ACTIVE                | CDIP         | J               | 20   | 1           | TBD                     | A42 SNPB         | N / A for Pkg Type           |
| SNJ54ACT240W     | ACTIVE                | CFP          | W               | 20   | 1           | TBD                     | A42              | N / A for Pkg Type           |

<sup>(1)</sup> The marketing status values are defined as follows:

**ACTIVE:** Product device recommended for new designs.

**LIFEBUY:** TI has announced that the device will be discontinued, and a lifetime-buy period is in effect.

**NRND:** Not recommended for new designs. Device is in production to support existing customers, but TI does not recommend using this part in a new design.

**PREVIEW:** Device has been announced but is not in production. Samples may or may not be available.

**OBSOLETE:** TI has discontinued the production of the device.

---

(2) Eco Plan - The planned eco-friendly classification: Pb-Free (RoHS), Pb-Free (RoHS Exempt), or Green (RoHS & no Sb/Br) - please check <http://www.ti.com/productcontent> for the latest availability information and additional product content details.

**TBD:** The Pb-Free/Green conversion plan has not been defined.

**Pb-Free (RoHS):** TI's terms "Lead-Free" or "Pb-Free" mean semiconductor products that are compatible with the current RoHS requirements for all 6 substances, including the requirement that lead not exceed 0.1% by weight in homogeneous materials. Where designed to be soldered at high temperatures, TI Pb-Free products are suitable for use in specified lead-free processes.

**Pb-Free (RoHS Exempt):** This component has a RoHS exemption for either 1) lead-based flip-chip solder bumps used between the die and package, or 2) lead-based die adhesive used between the die and leadframe. The component is otherwise considered Pb-Free (RoHS compatible) as defined above.

**Green (RoHS & no Sb/Br):** TI defines "Green" to mean Pb-Free (RoHS compatible), and free of Bromine (Br) and Antimony (Sb) based flame retardants (Br or Sb do not exceed 0.1% by weight in homogeneous material)

(3) MSL, Peak Temp. -- The Moisture Sensitivity Level rating according to the JEDEC industry standard classifications, and peak solder temperature.

**Important Information and Disclaimer:**The information provided on this page represents TI's knowledge and belief as of the date that it is provided. TI bases its knowledge and belief on information provided by third parties, and makes no representation or warranty as to the accuracy of such information. Efforts are underway to better integrate information from third parties. TI has taken and continues to take reasonable steps to provide representative and accurate information but may not have conducted destructive testing or chemical analysis on incoming materials and chemicals. TI and TI suppliers consider certain information to be proprietary, and thus CAS numbers and other limited information may not be available for release.

In no event shall TI's liability arising out of such information exceed the total purchase price of the TI part(s) at issue in this document sold by TI to Customer on an annual basis.

J (R-GDIP-T\*\*)

14 LEADS SHOWN

CERAMIC DUAL IN-LINE PACKAGE



| DIM \ PINS ** | 14                     | 16                     | 18                     | 20                     |
|---------------|------------------------|------------------------|------------------------|------------------------|
| A             | 0.300<br>(7,62)<br>BSC | 0.300<br>(7,62)<br>BSC | 0.300<br>(7,62)<br>BSC | 0.300<br>(7,62)<br>BSC |
| B MAX         | 0.785<br>(19,94)       | .840<br>(21,34)        | 0.960<br>(24,38)       | 1.060<br>(26,92)       |
| B MIN         | —                      | —                      | —                      | —                      |
| C MAX         | 0.300<br>(7,62)        | 0.300<br>(7,62)        | 0.310<br>(7,87)        | 0.300<br>(7,62)        |
| C MIN         | 0.245<br>(6,22)        | 0.245<br>(6,22)        | 0.220<br>(5,59)        | 0.245<br>(6,22)        |



4040083/F 03/03

- NOTES:
- A. All linear dimensions are in inches (millimeters).
  - B. This drawing is subject to change without notice.
  - C. This package is hermetically sealed with a ceramic lid using glass frit.
  - D. Index point is provided on cap for terminal identification only on press ceramic glass frit seal only.
  - E. Falls within MIL STD 1835 GDIP1-T14, GDIP1-T16, GDIP1-T18 and GDIP1-T20.

W (R-GDFP-F20)

CERAMIC DUAL FLATPACK

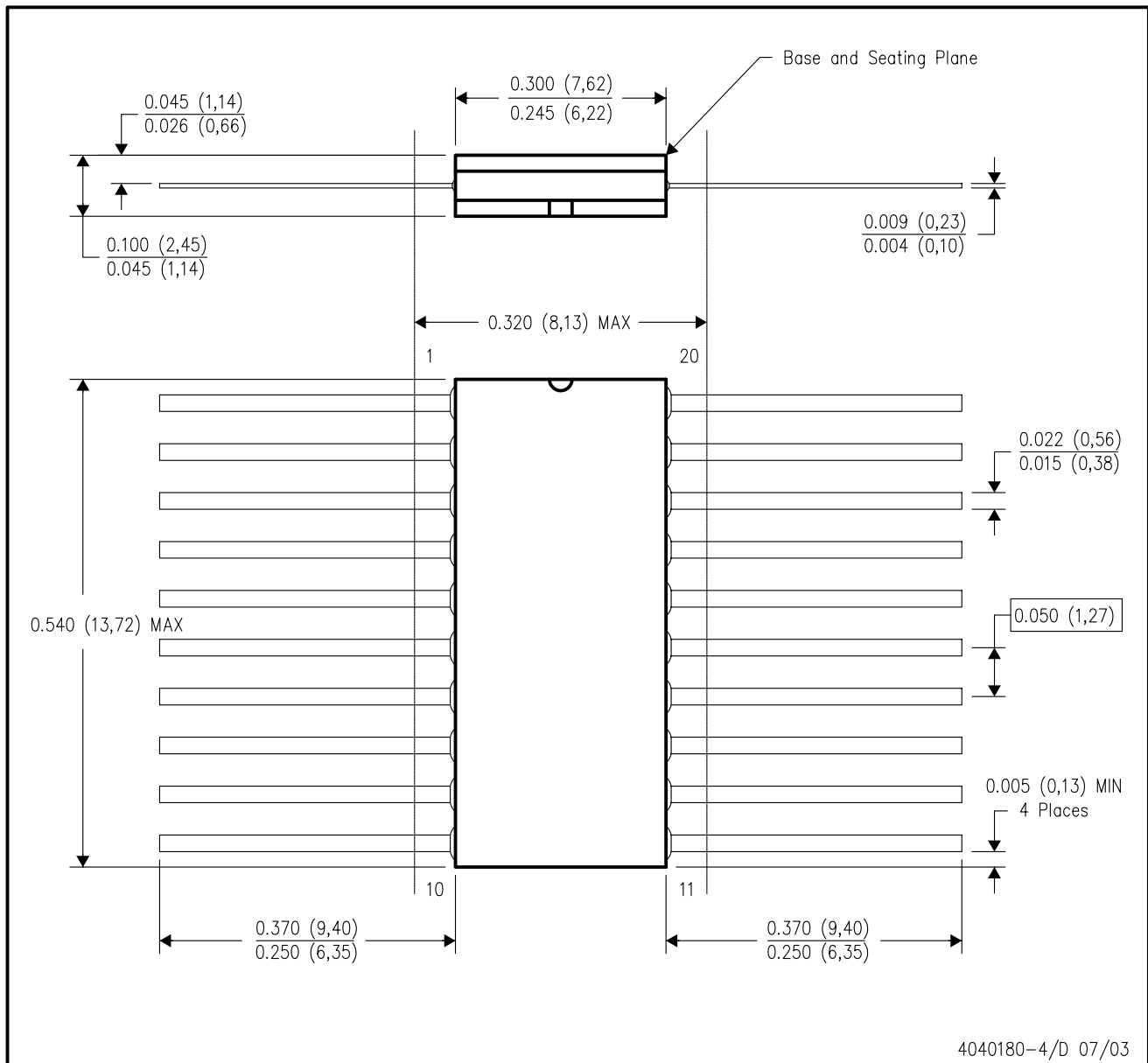

- NOTES:
- A. All linear dimensions are in inches (millimeters).
  - B. This drawing is subject to change without notice.
  - C. This package can be hermetically sealed with a ceramic lid using glass frit.
  - D. Index point is provided on cap for terminal identification only.
  - E. Falls within Mil-Std 1835 GDFP2-F20

FK (S-CQCC-N\*\*)

LEADLESS CERAMIC CHIP CARRIER

28 TERMINAL SHOWN



- NOTES:
- A. All linear dimensions are in inches (millimeters).
  - B. This drawing is subject to change without notice.
  - C. This package can be hermetically sealed with a metal lid.
  - D. The terminals are gold plated.
  - E. Falls within JEDEC MS-004

N (R-PDIP-T\*\*)

PLASTIC DUAL-IN-LINE PACKAGE

16 PINS SHOWN



- NOTES:
- A. All linear dimensions are in inches (millimeters).
  - B. This drawing is subject to change without notice.
  - Falls within JEDEC MS-001, except 18 and 20 pin minimum body length (Dim A).
  - The 20 pin end lead shoulder width is a vendor option, either half or full width.

DW (R-PDSO-G20)

PLASTIC SMALL-OUTLINE PACKAGE

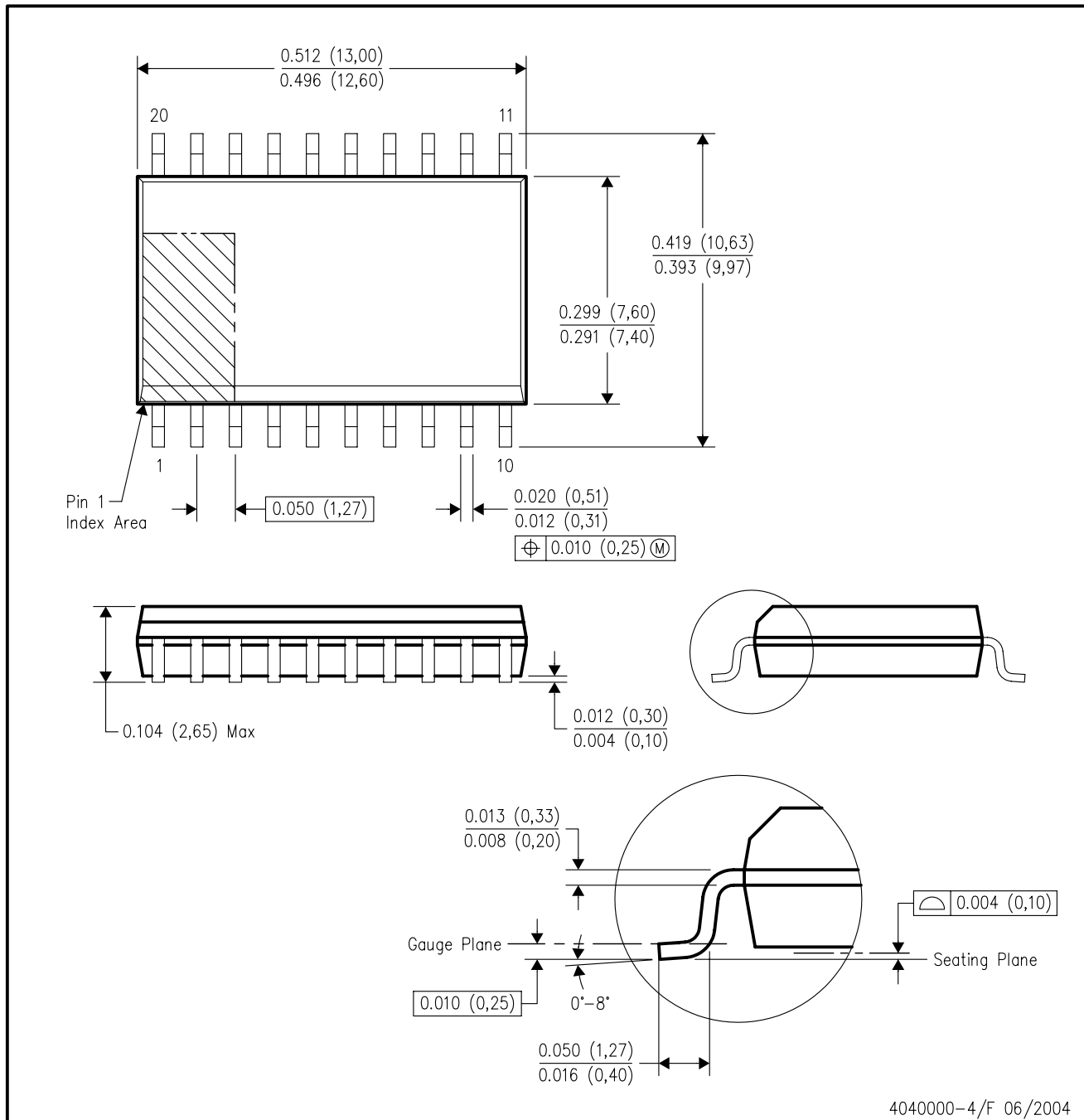

- NOTES:
- A. All linear dimensions are in inches (millimeters).
  - B. This drawing is subject to change without notice.
  - C. Body dimensions do not include mold flash or protrusion not to exceed 0.006 (0,15).
  - D. Falls within JEDEC MS-013 variation AC.

# MECHANICAL DATA

NS (R-PDSO-G\*\*)

PLASTIC SMALL-OUTLINE PACKAGE

14-PINS SHOWN



- NOTES:
- A. All linear dimensions are in millimeters.
  - B. This drawing is subject to change without notice.
  - C. Body dimensions do not include mold flash or protrusion, not to exceed 0,15.

DB (R-PDSO-G\*\*)

PLASTIC SMALL-OUTLINE

28 PINS SHOWN



- NOTES: A. All linear dimensions are in millimeters.  
 B. This drawing is subject to change without notice.  
 C. Body dimensions do not include mold flash or protrusion not to exceed 0,15.  
 D. Falls within JEDEC MO-150

PW (R-PDSO-G\*\*)

PLASTIC SMALL-OUTLINE PACKAGE

14 PINS SHOWN



4040064/F 01/97

- NOTES: A. All linear dimensions are in millimeters.  
 B. This drawing is subject to change without notice.  
 C. Body dimensions do not include mold flash or protrusion not to exceed 0,15.  
 D. Falls within JEDEC MO-153

## IMPORTANT NOTICE

Texas Instruments Incorporated and its subsidiaries (TI) reserve the right to make corrections, modifications, enhancements, improvements, and other changes to its products and services at any time and to discontinue any product or service without notice. Customers should obtain the latest relevant information before placing orders and should verify that such information is current and complete. All products are sold subject to TI's terms and conditions of sale supplied at the time of order acknowledgment.

TI warrants performance of its hardware products to the specifications applicable at the time of sale in accordance with TI's standard warranty. Testing and other quality control techniques are used to the extent TI deems necessary to support this warranty. Except where mandated by government requirements, testing of all parameters of each product is not necessarily performed.

TI assumes no liability for applications assistance or customer product design. Customers are responsible for their products and applications using TI components. To minimize the risks associated with customer products and applications, customers should provide adequate design and operating safeguards.

TI does not warrant or represent that any license, either express or implied, is granted under any TI patent right, copyright, mask work right, or other TI intellectual property right relating to any combination, machine, or process in which TI products or services are used. Information published by TI regarding third-party products or services does not constitute a license from TI to use such products or services or a warranty or endorsement thereof. Use of such information may require a license from a third party under the patents or other intellectual property of the third party, or a license from TI under the patents or other intellectual property of TI.

Reproduction of information in TI data books or data sheets is permissible only if reproduction is without alteration and is accompanied by all associated warranties, conditions, limitations, and notices. Reproduction of this information with alteration is an unfair and deceptive business practice. TI is not responsible or liable for such altered documentation.

Resale of TI products or services with statements different from or beyond the parameters stated by TI for that product or service voids all express and any implied warranties for the associated TI product or service and is an unfair and deceptive business practice. TI is not responsible or liable for any such statements.

Following are URLs where you can obtain information on other Texas Instruments products and application solutions:

| <b>Products</b>    |  | <b>Applications</b> |  |
|--------------------|--|---------------------|--|
| Amplifiers         | <a href="http://amplifier.ti.com">amplifier.ti.com</a>             | Audio               | <a href="http://www.ti.com/audio">www.ti.com/audio</a>                   |
| Data Converters    | <a href="http://dataconverter.ti.com">dataconverter.ti.com</a>     | Automotive          | <a href="http://www.ti.com/automotive">www.ti.com/automotive</a>         |
| DSP                | <a href="http://dsp.ti.com">dsp.ti.com</a>                         | Broadband           | <a href="http://www.ti.com/broadband">www.ti.com/broadband</a>           |
| Interface          | <a href="http://interface.ti.com">interface.ti.com</a>             | Digital Control     | <a href="http://www.ti.com/digitalcontrol">www.ti.com/digitalcontrol</a> |
| Logic              | <a href="http://logic.ti.com">logic.ti.com</a>                     | Military            | <a href="http://www.ti.com/military">www.ti.com/military</a>             |
| Power Mgmt         | <a href="http://power.ti.com">power.ti.com</a>                     | Optical Networking  | <a href="http://www.ti.com/opticalnetwork">www.ti.com/opticalnetwork</a> |
| Microcontrollers   | <a href="http://microcontroller.ti.com">microcontroller.ti.com</a> | Security            | <a href="http://www.ti.com/security">www.ti.com/security</a>             |
| Low Power Wireless | <a href="http://www.ti.com/lpw">www.ti.com/lpw</a>                 | Telephony           | <a href="http://www.ti.com/telephony">www.ti.com/telephony</a>           |
|                    |  | Video & Imaging     | <a href="http://www.ti.com/video">www.ti.com/video</a>                   |
|                    |  | Wireless            | <a href="http://www.ti.com/wireless">www.ti.com/wireless</a>             |

Mailing Address: Texas Instruments  
Post Office Box 655303 Dallas, Texas 75265