

- Dual Independent FIFOs Organized as:
 64 Words by 1 Bit Each – SN74ACT2227
 256 Words by 1 Bit Each – SN74ACT2229
- Free-Running Read and Write Clocks Can Be Asynchronous or Coincident on Each FIFO
- Input-Ready Flags Synchronized to Write Clocks
- Output-Ready Flags Synchronized to Read Clocks
- Half-Full and Almost-Full/Almost-Empty Flags
- Support Clock Frequencies up to 60 MHz
- Access Times of 9 ns
- 3-State Data Outputs
- Low-Power Advanced CMOS Technology
- Packaged in 28-Pin SOIC Package

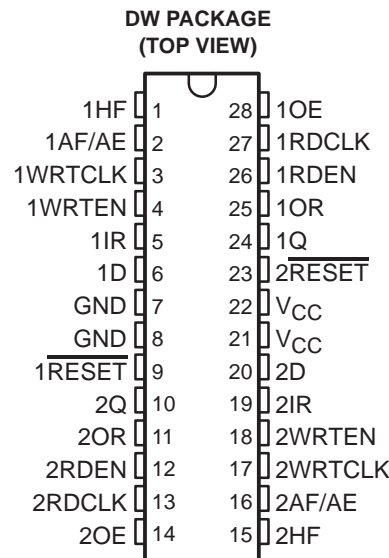

description

The SN74ACT2227 and SN74ACT2229 are dual FIFOs suited for a wide range of serial-data buffering applications including elastic stores for frequencies up to OC-1 telecommunication rates. Each FIFO on the chip is arranged as 64×1 (SN74ACT2227) or 256×1 (SN74ACT2229) and has control signals and status flags for independent operation. Output flags for each FIFO include input ready (1IR or 2IR), output ready (1OR or 2OR), half full (1HF or 2HF), and almost full/almost empty (1AF/AE or 2AF/AE).

Serial data is written into a FIFO on the low-to-high transition of the write-clock (1WRTCLK or 2WRTCLK) input when the write-enable (1WRTEN or 2WRTEN) input and input-ready flag (1IR or 2IR) output are both high. Serial data is read from a FIFO on the low-to-high transition of the read-clock (1RDCLK or 2RDCLK) input when the read-enable (1RDEN or 2RDEN) input and output-ready flag (1OR or 2OR) output are both high. The read and write clocks of a FIFO can be asynchronous to one another. A FIFO data output (1Q or 2Q) is in the high-impedance state when its output-enable (1OE or 2OE) input is low.

Each input-ready flag (1IR or 2IR) is synchronized by two flip-flop stages to its write clock (1WRTCLK or 2WRTCLK), and each output-ready flag (1OR or 2OR) is synchronized by three flip-flop stages to its read clock (1RDCLK or 2RDCLK). This multistage synchronization ensures reliable flag-output states when data is written and read asynchronously.

A half-full flag (1HF or 2HF) is high when the number of bits stored in its FIFO is greater than or equal to half the depth of the FIFO. An almost-full/almost-empty flag (1AF/AE or 2AF/AE) is high when eight or fewer bits are stored in its FIFO and when eight or fewer empty locations are left in the FIFO. A bit present on the data output is not stored in the FIFO.

The SN74ACT2227 and SN74ACT2229 are characterized for operation from -40°C to 85°C .

For more information on this device family, see the application report *FIFOs With a Word Width of One Bit* (literature number SCAA006).



Please be aware that an important notice concerning availability, standard warranty, and use in critical applications of Texas Instruments semiconductor products and disclaimers thereto appears at the end of this data sheet.

SN74ACT2227, SN74ACT2229
DUAL 64 × 1, DUAL 256 × 1
FIRST-IN, FIRST-OUT MEMORIES
 SCAS220C – JUNE 1992 – REVISED OCTOBER 1997

logic symbols†

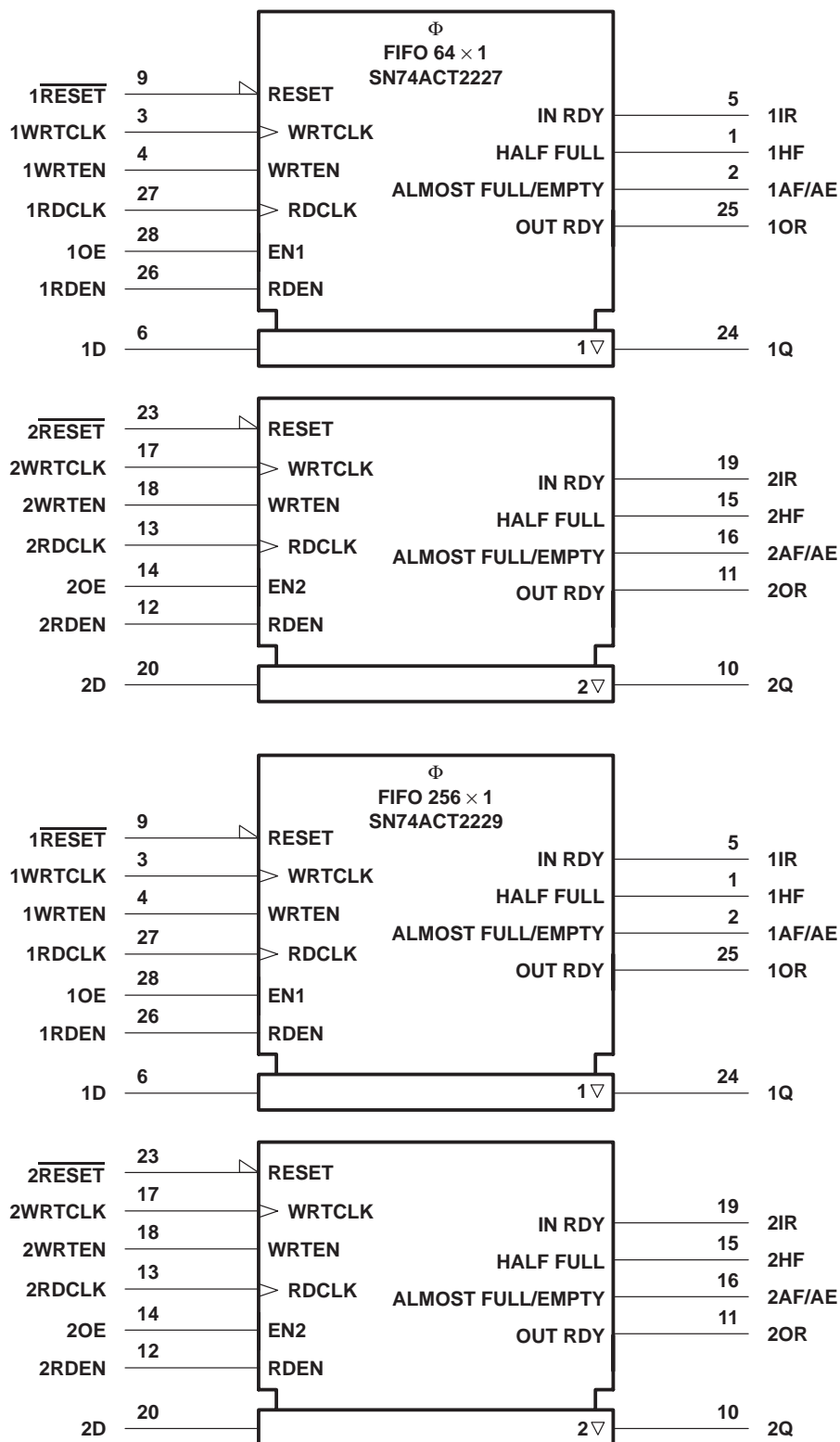

† These symbols are in accordance with ANSI/IEEE Std 91-1984 and IEC Publication 617-12.



SN74ACT2227 functional block diagram (each FIFO)

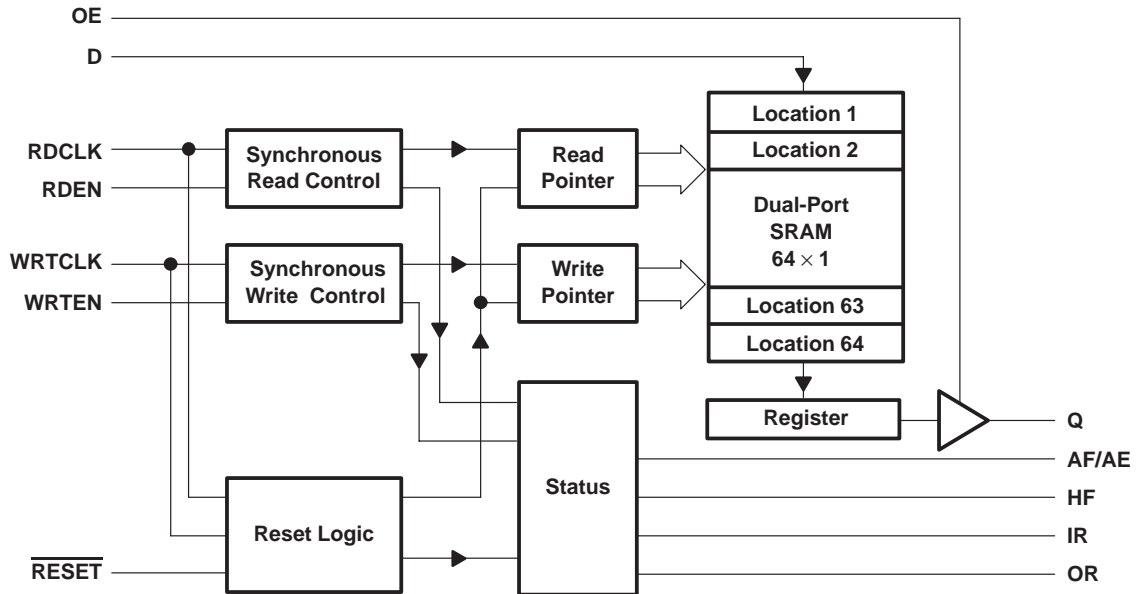

SN74ACT2229 functional block diagram (each FIFO)

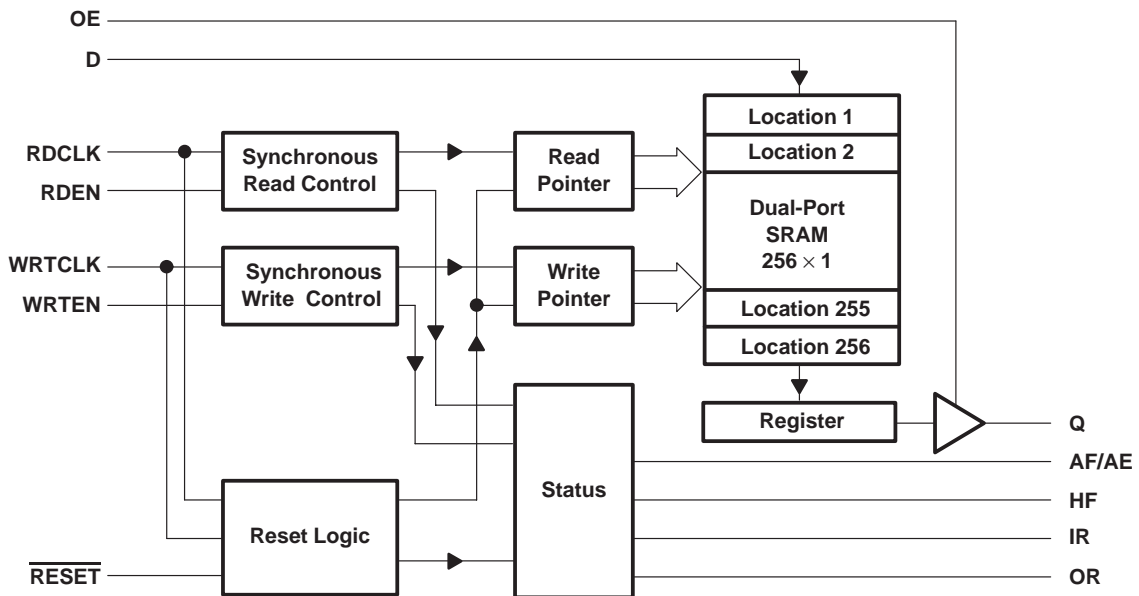

Terminal Functions

TERMINAL NAME	NO.	I/O	DESCRIPTION
1AF/AE 2AF/AE	2 16	O	Almost-full/almost-empty flag. AF/AE is high when the memory is eight locations or fewer from a full or empty state. AF/AE is set high after reset.
1D 2D	6 20	I	Data input
GND	7, 8		Ground
1HF 2HF	1 15	O	Half-full flag. HF is high when the number of bits stored in memory is greater than or equal to half the FIFO depth. HF is set low after reset.
1IR 2IR	5 19	O	Input-ready flag. IR is synchronized to the low-to-high transition of WRTCLK. When IR is low, the FIFO is full and writes are disabled. IR is set low during reset and is set high on the second low-to-high transition of WRTCLK after reset.
1OE 2OE	28 14	I	Output enable. The data output of a FIFO is active when OE is high and in the high-impedance state when OE is low.
1OR 2OR	25 11	O	Output-ready flag. OR is synchronized to the low-to-high transition of RDCLK. When OR is low, the FIFO is empty and reads are disabled. Ready data is present on the data output when OR is high. OR is set low during reset and set high on the third low-to-high transition of RDCLK after the first word is loaded to empty memory.
1Q 2Q	24 10	O	Data outputs. After the first valid write to empty memory, the first bit is output on the third rising edge of RDCLK. OR for the FIFO is asserted high to indicate ready data.
1RDCLK 2RDCLK	27 13	I	Read clock. RDCLK is a continuous clock and can be independent of any other clock on the device. A low-to-high transition of RDCLK reads data from memory when the FIFO RDEN and OR are high. OR is synchronous with the low-to-high transition of RDCLK.
1RDEN 2RDEN	26 12	I	Read enable. When the RDEN and OR of a FIFO are high, data is read from the FIFO on the low-to-high transition of RDCLK.
1RESET 2RESET	9 23	I	Reset. To reset the FIFO, four low-to-high transitions of RDCLK and four low-to-high transitions of WRTCLK must occur while $\overline{\text{RESET}}$ is low. This sets HF, IR, and OR low and AF/AE high. Before it is used, a FIFO must be reset after power up.
VCC	21, 22		Supply voltage
1WRTCLK 2WRTCLK	3 17	I	Write clock. WRTCLK is a continuous clock and can be independent of any other clock on the device. A low-to-high transition of WRTCLK writes data to memory when WRTEN and IR are high. IR is synchronous with the low-to-high transition of WRTCLK.
1WRTEN 2WRTEN	4 18	I	Write enable. When WRTEN and IR are high, data is written to the FIFO on a low-to-high transition of WRTCLK.

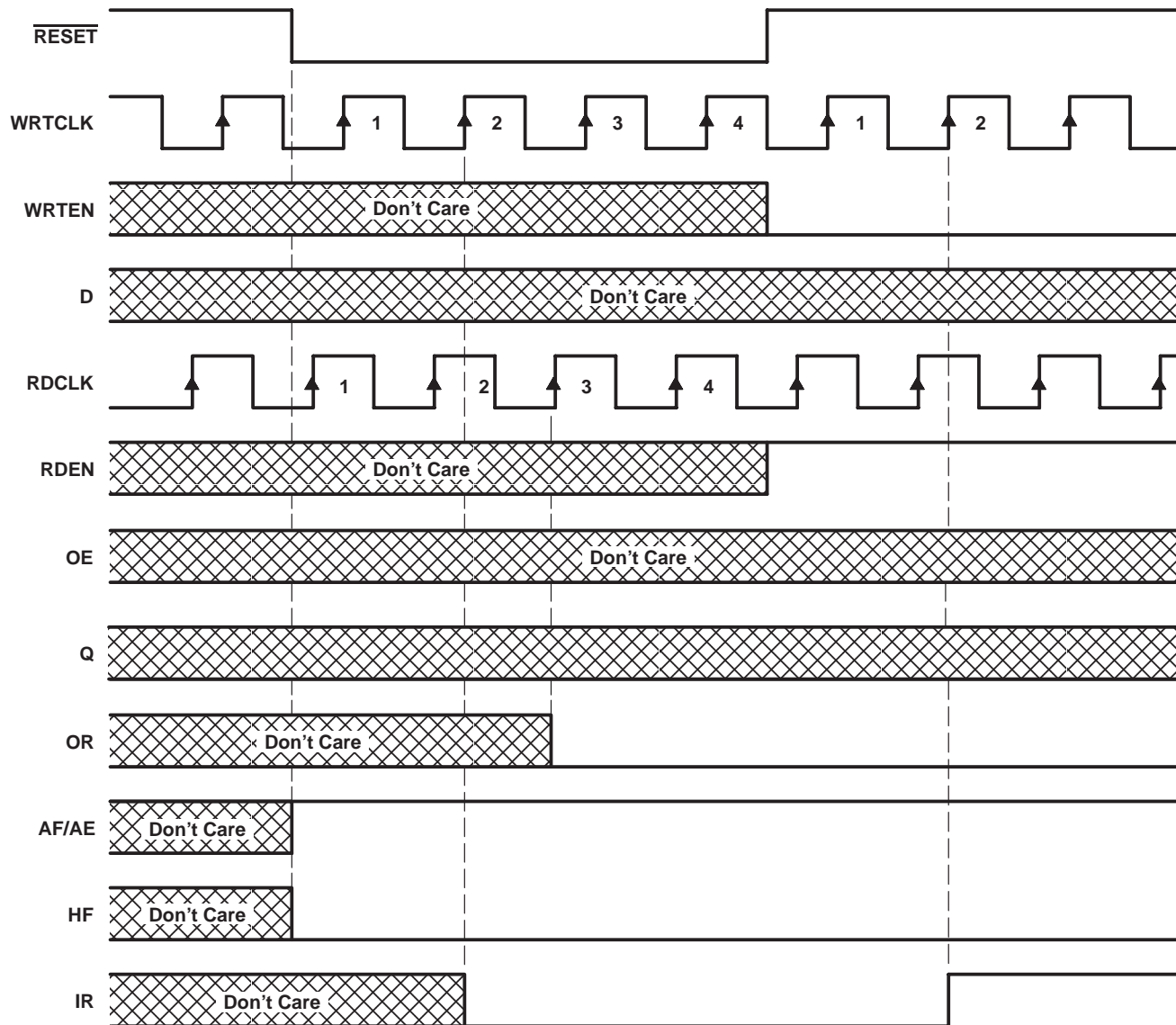
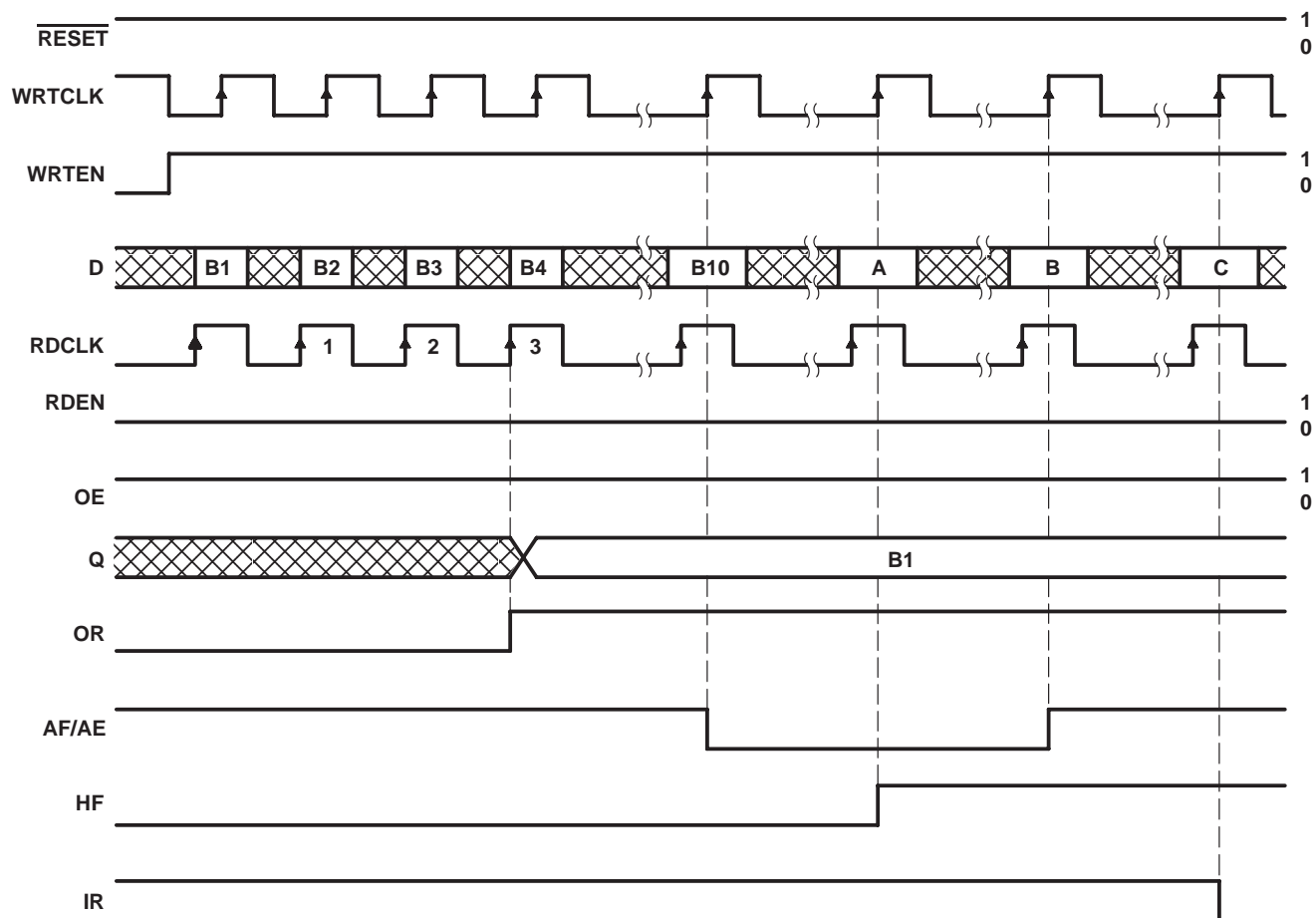

Figure 1. FIFO Reset

SN74ACT2227, SN74ACT2229
 DUAL 64 × 1, DUAL 256 × 1
 FIRST-IN, FIRST-OUT MEMORIES
 SCAS220C – JUNE 1992 – REVISED OCTOBER 1997



DATA BIT NUMBER BASED ON FIFO DEPTH

DEVICE	DATA BIT		
	A	B	C
SN74ACT2227	B33	B57	B65
SN74ACT2229	B129	B249	B257

Figure 2. FIFO Write

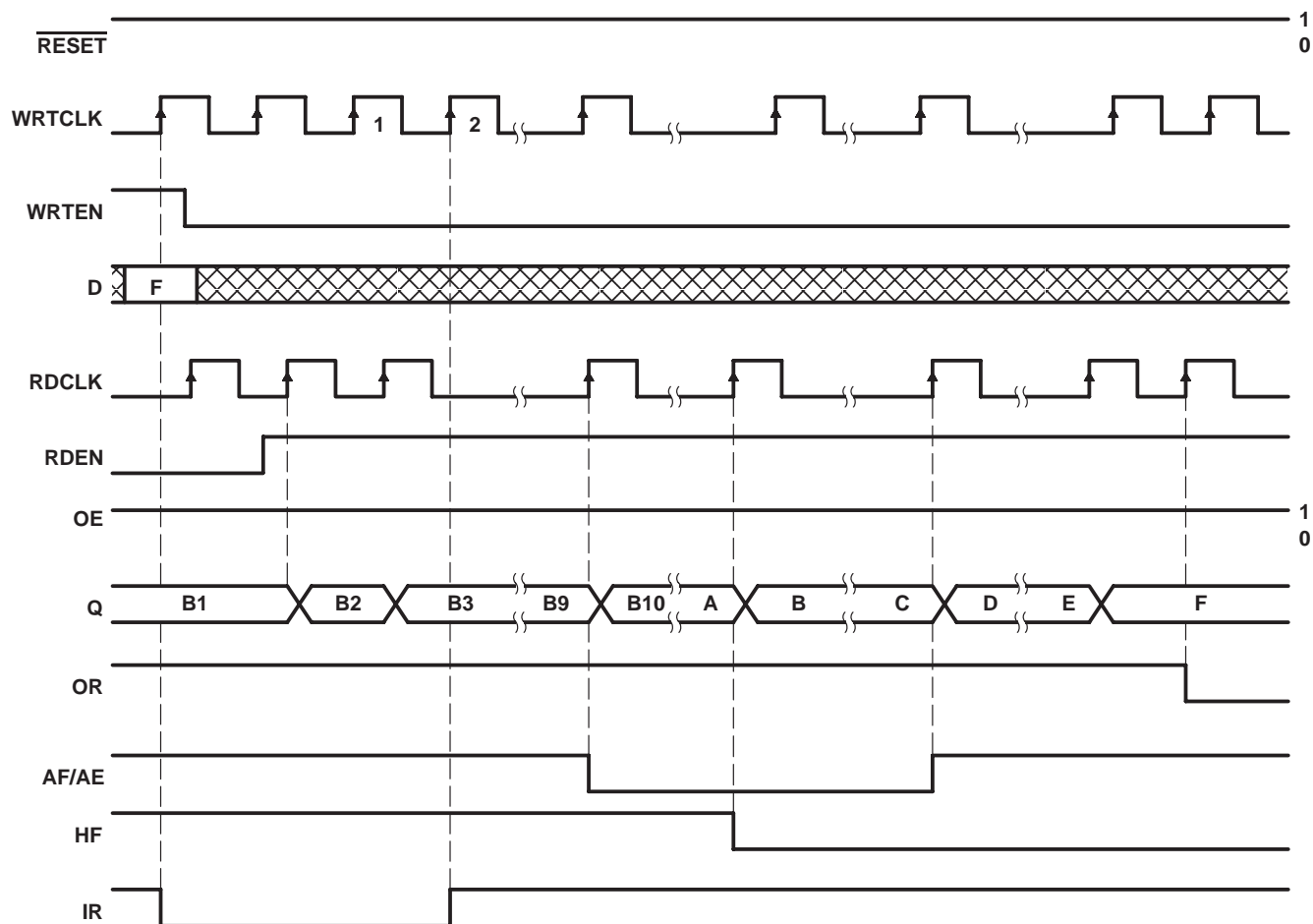

DATA BIT NUMBER BASED ON FIFO DEPTH

DEVICE	DATA BIT					
	A	B	C	D	E	F
SN74ACT2227	B33	B34	B56	B57	B64	B65
SN74ACT2229	B129	B130	B248	B249	B256	B257

Figure 3. FIFO Read

SN74ACT2227, SN74ACT2229
DUAL 64 × 1, DUAL 256 × 1
FIRST-IN, FIRST-OUT MEMORIES
 SCAS220C – JUNE 1992 – REVISED OCTOBER 1997

absolute maximum ratings over operating free-air temperature range (unless otherwise noted)†

Supply voltage range, V_{CC}	–0.5 V to 7 V
Input voltage range, V_I (see Note 1)	–0.5 V to $V_{CC} + 0.5$ V
Output voltage range, V_O (see Note 1)	–0.5 V to $V_{CC} + 0.5$ V
Voltage applied to a disabled 3-state output	5.5 V
Input clamp current, I_{IK} ($V_I < 0$ or $V_I > V_{CC}$)	±20 mA
Output clamp current, I_{OK} ($V_O < 0$ or $V_O > V_{CC}$)	±50 mA
Continuous output current, I_O ($V_O = 0$ to V_{CC})	±50 mA
Continuous current through V_{CC} or GND	±200 mA
Package thermal impedance, θ_{JA} (see Note 2)	78°C/W
Storage temperature range, T_{stg}	–65°C to 150°C

† Stresses beyond those listed under “absolute maximum ratings” may cause permanent damage to the device. These are stress ratings only, and functional operation of the device at these or any other conditions beyond those indicated under “recommended operating conditions” is not implied. Exposure to absolute-maximum-rated conditions for extended periods may affect device reliability.

- NOTES: 1. The input and output voltage ratings may be exceeded provided that the input and output current ratings are observed.
 2. The package thermal impedance is calculated in accordance with JESD 51.

recommended operating conditions

		MIN	MAX	UNIT
V_{CC}	Supply voltage	4.5	5.5	V
V_{IH}	High-level input voltage	2		V
V_{IL}	Low-level input voltage		0.8	V
I_{OH}	High-level output current		–8	mA
I_{OL}	Low-level output current	Q outputs	16	mA
		Flags	8	
T_A	Operating free-air temperature	–40	85	°C

electrical characteristics over recommended operating free-air temperature range (unless otherwise noted)

PARAMETER	TEST CONDITIONS		MIN	TYP‡	MAX	UNIT
V_{OH}	$V_{CC} = 4.5$ V,	$I_{OH} = -8$ mA	2.4			V
V_{OL}	Flags	$V_{CC} = 4.5$ V,			0.5	V
	Q outputs	$V_{CC} = 4.5$ V,			0.5	
I_I	$V_{CC} = 5.5$ V,	$V_I = V_{CC}$ or 0			±5	µA
I_{OZ}	$V_{CC} = 5.5$ V,	$V_O = V_{CC}$ or 0			±5	µA
I_{CC}	$V_I = V_{CC} - 0.2$ V or 0				400	µA
ΔI_{CC}^{\S}	$V_{CC} = 5.5$ V,	One input at 3.4 V, Other inputs at V_{CC} or GND			1	mA
C_i	$V_I = 0$,	$f = 1$ MHz		4		pF
C_o	$V_O = 0$,	$f = 1$ MHz		8		pF

‡ All typical values are at $V_{CC} = 5$ V, $T_A = 25^\circ\text{C}$.

§ This is the supply current when each input is at one of the specified TTL voltage levels rather than 0 V or V_{CC} .



timing requirements over recommended ranges of supply voltage and operating free-air temperature (unless otherwise noted) (see Figures 1 through 4)

			MIN	MAX	UNIT
f _{clock}	Clock frequency			60	MHz
t _w	Pulse duration	1WRTCLK, 2WRTCLK high or low	5		ns
		1RDCLK, 2RDCLK high or low	5		
t _{su}	Setup time	1D before 1WRTCLK↑ and 2D before 2WRTCLK↑	4.5		ns
		1WRTEN before 1WRTCLK↑ and 2WRTEN before 2WRTCLK↑	4.5		
		1RDEN before 1RDCLK↑ and 2RDEN before 2RDCLK↑	4		
		1RESET low before 1WRTCLK↑ and 2RESET low before 2WRTCLK↑†	6		
		1RESET low before 1RDCLK↑ and 2RESET low before 2RDCLK↑†	6		
t _h	Hold time	1D after 1WRTCLK↑ and 2D after 2WRTCLK↑	0		ns
		1WRTEN after 1WRTCLK↑ and 2WRTEN after 2WRTCLK↑	0		
		1RDEN after 1RDCLK↑ and 2RDEN after 2RDCLK↑	0		
		1RESET low after 1WRTCLK↑ and 2RESET low after 2WRTCLK↑†	6		
		1RESET low after 1RDCLK↑ and 2RESET low after 2RDCLK↑†	6		

† Requirement to count the clock edge as one of at least four needed to reset a FIFO

switching characteristics over recommended ranges of supply voltage and operating free-air temperature, C_L = 50 pF (unless otherwise noted) (see Figure 4)

PARAMETER	FROM (INPUT)	TO (OUTPUT)	MIN	MAX	UNIT
f _{max}	1WRTCLK, 2WRTCLK, or 1RDCLK, 2RDCLK		60		MHz
t _{pd}	1RDCLK↑, 2RDCLK↑	1Q, 2Q	2	9	ns
t _{pd}	1WRTCLK↑, 2WRTCLK↑	1IR, 2IR	1	8	ns
t _{pd}	1RDCLK↑, 2RDCLK↑	1OR, 2OR	1	8	ns
t _{pd}	1WRTCLK↑, 2WRTCLK↑	1AF/AE, 2AF/AE	3	14	ns
	1RDCLK↑, 2RDCLK↑		3	14	
t _{PLH}	1WRTCLK↑, 2WRTCLK↑	1HF, 2HF	2	12	ns
t _{PHL}	1RDCLK↑, 2RDCLK↑		3	14	ns
t _{PLH}	1RESET, 2RESET low	1AF/AE, 2AF/AE	1	17	ns
t _{PHL}		1HF, 2HF	1	18	ns
t _{en}	1OE, 2OE	1Q, 2Q	0	8	ns
t _{dis}	1OE, 2OE	1Q, 2Q	0	8	ns

PARAMETER MEASUREMENT INFORMATION

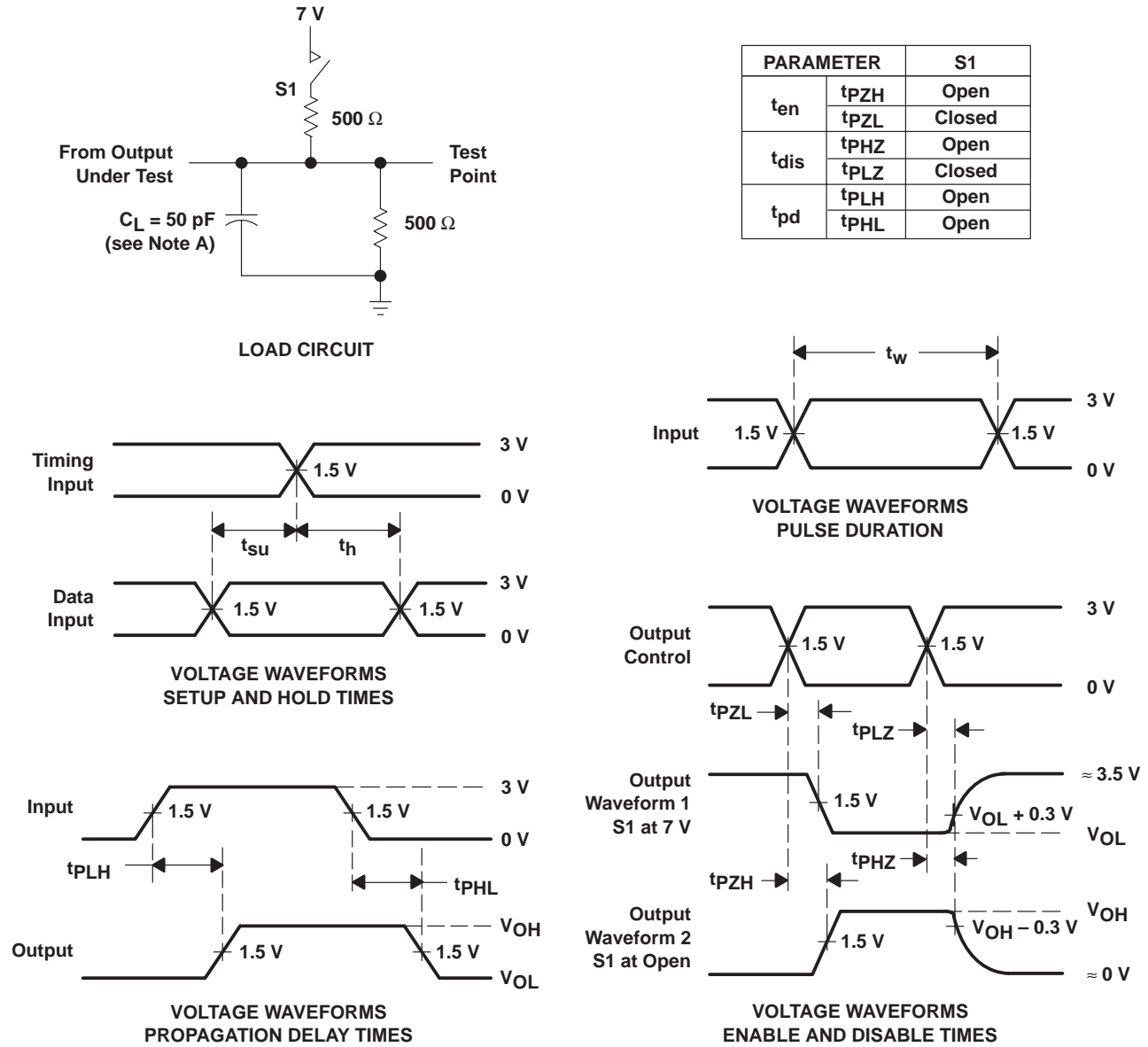

NOTE A: C_L includes probe and jig capacitance.

Figure 4. Load Circuit and Voltage Waveforms

TYPICAL CHARACTERISTICS

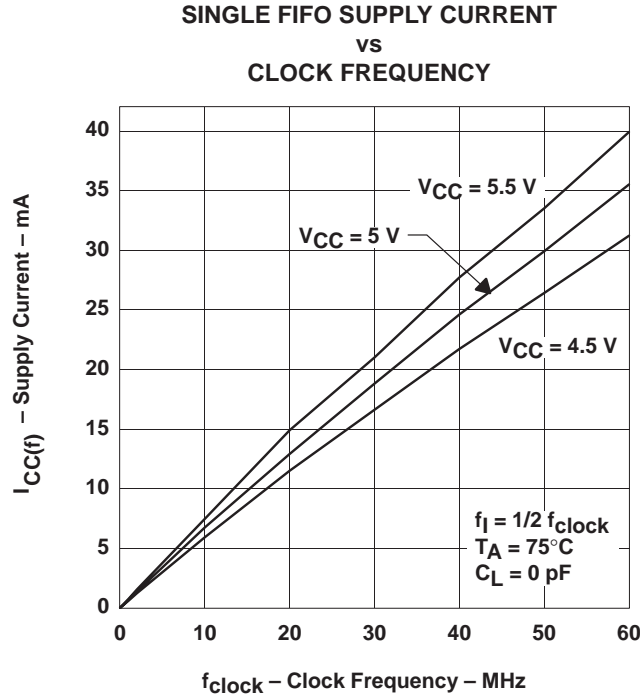

Figure 5

calculating power dissipation

Data for Figure 5 is taken with one FIFO active and one FIFO idle on the device. The active FIFO has both writes and reads enabled with its read clock (RDCLK) and write clock (WRTCLK) operating at the rate specified by f_{clock} . The data input rate and data output rate are half the f_{clock} rate, and the data output is disconnected. A close approximation to the total device power can be found by Figure 5, determining the capacitive load on the data output and determining the number of SN74ACT2227/2229 inputs driven by TTL high levels.

With $I_{CC(f)}$ taken from Figure 5, the maximum power dissipation (P_T) of one FIFO on the SN74ACT2227 or SN74ACT2229 can be calculated by:

$$P_T = V_{CC} \times [I_{CC(f)} + (N \times \Delta I_{CC} \times dc)] + (C_L \times V_{CC}^2 \times f_o)$$

where:

- N = number of inputs driven by TTL levels
- ΔI_{CC} = increase in power-supply current for each input at a TTL high level
- dc = duty cycle of inputs at a TTL high level of 3.4 V
- C_L = output capacitive load
- f_o = switching frequency of an output

APPLICATION INFORMATION

An example of concentrating two independent serial-data signals into a single composite data signal with the use of an SN74ACT2227 or SN74ACT2229 device is shown in Figure 6. The input data to the FIFOs share the same average (mean) frequency and the mean frequency of the SYS_CLOCK is greater than or equal to the sum of the individual mean input rates. A single-bit FIFO is needed for each additional input data signal that is time-division multiplexed into the composite signal.

The FIFO memories provide a buffer to absorb clock jitter generated by the transmission systems of incoming signals and synchronize the phase-independent inputs to one another. FIFO half-full (HF) flags are used to signal the multiplexer to start fetching data from the buffers. The state of the flags also can be used to indicate when a FIFO read should be suppressed to regulate the output flow (pulse-stuffing control). The FIFO almost-full/almost-empty (AF/AE) flags can be used in place of the half-full flags to reduce transmission delay.

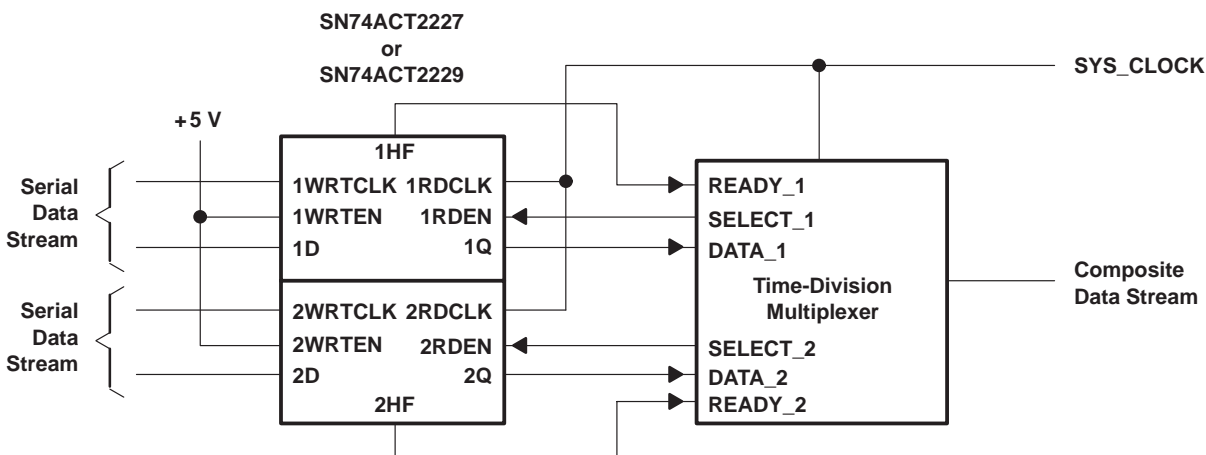

Figure 6. Time-Division Multiplexing Using the SN74ACT2227 or SN74ACT2229

IMPORTANT NOTICE

Texas Instruments and its subsidiaries (TI) reserve the right to make changes to their products or to discontinue any product or service without notice, and advise customers to obtain the latest version of relevant information to verify, before placing orders, that information being relied on is current and complete. All products are sold subject to the terms and conditions of sale supplied at the time of order acknowledgement, including those pertaining to warranty, patent infringement, and limitation of liability.

TI warrants performance of its semiconductor products to the specifications applicable at the time of sale in accordance with TI's standard warranty. Testing and other quality control techniques are utilized to the extent TI deems necessary to support this warranty. Specific testing of all parameters of each device is not necessarily performed, except those mandated by government requirements.

CERTAIN APPLICATIONS USING SEMICONDUCTOR PRODUCTS MAY INVOLVE POTENTIAL RISKS OF DEATH, PERSONAL INJURY, OR SEVERE PROPERTY OR ENVIRONMENTAL DAMAGE ("CRITICAL APPLICATIONS"). TI SEMICONDUCTOR PRODUCTS ARE NOT DESIGNED, AUTHORIZED, OR WARRANTED TO BE SUITABLE FOR USE IN LIFE-SUPPORT DEVICES OR SYSTEMS OR OTHER CRITICAL APPLICATIONS. INCLUSION OF TI PRODUCTS IN SUCH APPLICATIONS IS UNDERSTOOD TO BE FULLY AT THE CUSTOMER'S RISK.

In order to minimize risks associated with the customer's applications, adequate design and operating safeguards must be provided by the customer to minimize inherent or procedural hazards.

TI assumes no liability for applications assistance or customer product design. TI does not warrant or represent that any license, either express or implied, is granted under any patent right, copyright, mask work right, or other intellectual property right of TI covering or relating to any combination, machine, or process in which such semiconductor products or services might be or are used. TI's publication of information regarding any third party's products or services does not constitute TI's approval, warranty or endorsement thereof.