

**SN74ACT2226, SN74ACT2228**  
**DUAL 64 × 1, DUAL 256 × 1**  
**CLOCKED FIRST-IN, FIRST-OUT MEMORIES**  
 SCAS219C – JUNE 1992 – REVISED OCTOBER 1997

- **Dual Independent FIFOs Organized as:**  
 64 Words by 1 Bit Each – SN74ACT2226  
 256 Words by 1 Bit Each – SN74ACT2228
- **Free-Running Read and Write Clocks Can Be Asynchronous or Coincident on Each FIFO**
- **Input-Ready Flags Synchronized to Write Clocks**
- **Output-Ready Flags Synchronized to Read Clocks**
- **Half-Full and Almost-Full/Almost-Empty Flags**
- **Support Clock Frequencies up to 22 MHz**
- **Access Times of 20 ns**
- **Low-Power Advanced CMOS Technology**
- **Packaged in 24-Pin Small-Outline Integrated-Circuit Package**

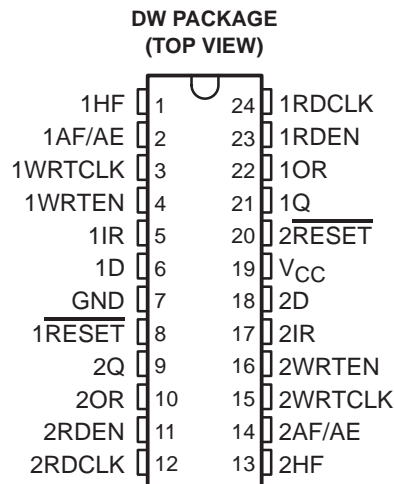

## description

The SN74ACT2226 and SN74ACT2228 are dual FIFOs suited for a wide range of serial-data buffering applications, including elastic stores for frequencies up to T2 telecommunication rates. Each FIFO on the chip is arranged as 64 × 1 (SN74ACT2226) or 256 × 1 (SN74ACT2228) and has control signals and status flags for independent operation. Output flags for each FIFO include input ready (1IR or 2IR), output ready (1OR or 2OR), half full (1HF or 2HF), and almost full/almost empty (1AF/AE or 2AF/AE).

Serial data is written into a FIFO on the low-to-high transition of the write-clock (1WRTCLK or 2WRTCLK) input when the write-enable (1WRTEN or 2WRTEN) input and input-ready flag (1IR or 2IR) output are both high. Serial data is read from a FIFO on the low-to-high transition of the read-clock (1RDCLK or 2RDCLK) input when the read-enable (1RDEN or 2RDEN) input and output-ready flag (1OR or 2OR) output are both high. The read and write clocks of a FIFO can be asynchronous to one another.

Each input-ready flag (1IR or 2IR) is synchronized by two flip-flop stages to its write clock (1WRTCLK or 2WRTCLK), and each output-ready flag (1OR or 2OR) is synchronized by three flip-flop stages to its read clock (1RDCLK or 2RDCLK). This multistage synchronization ensures reliable flag-output states when data is written and read asynchronously.

A half-full flag (1HF or 2HF) is high when the number of bits stored in its FIFO is greater than or equal to half the depth of the FIFO. An almost-full/almost-empty flag (1AF/AE or 2AF/AE) is high when eight or fewer bits are stored in its FIFO and when eight or fewer empty locations are left in the FIFO. A bit present on the data output is not stored in the FIFO.

The SN74ACT2226 and SN74ACT2228 are characterized for operation from –40°C to 85°C.

For more information on this device family, see the application report *FIFOs With a Word Width of One Bit* (literature number SCAA006).



Please be aware that an important notice concerning availability, standard warranty, and use in critical applications of Texas Instruments semiconductor products and disclaimers thereto appears at the end of this data sheet.

PRODUCTION DATA information is current as of publication date. Products conform to specifications per the terms of Texas Instruments standard warranty. Production processing does not necessarily include testing of all parameters.

 **TEXAS  
INSTRUMENTS**

POST OFFICE BOX 655303 • DALLAS, TEXAS 75265

Copyright © 1997, Texas Instruments Incorporated

**SN74ACT2226, SN74ACT2228**  
**DUAL 64 × 1, DUAL 256 × 1**  
**CLOCKED FIRST-IN, FIRST-OUT MEMORIES**

SCAS219C – JUNE 1992 – REVISED OCTOBER 1997

**logic symbols†**

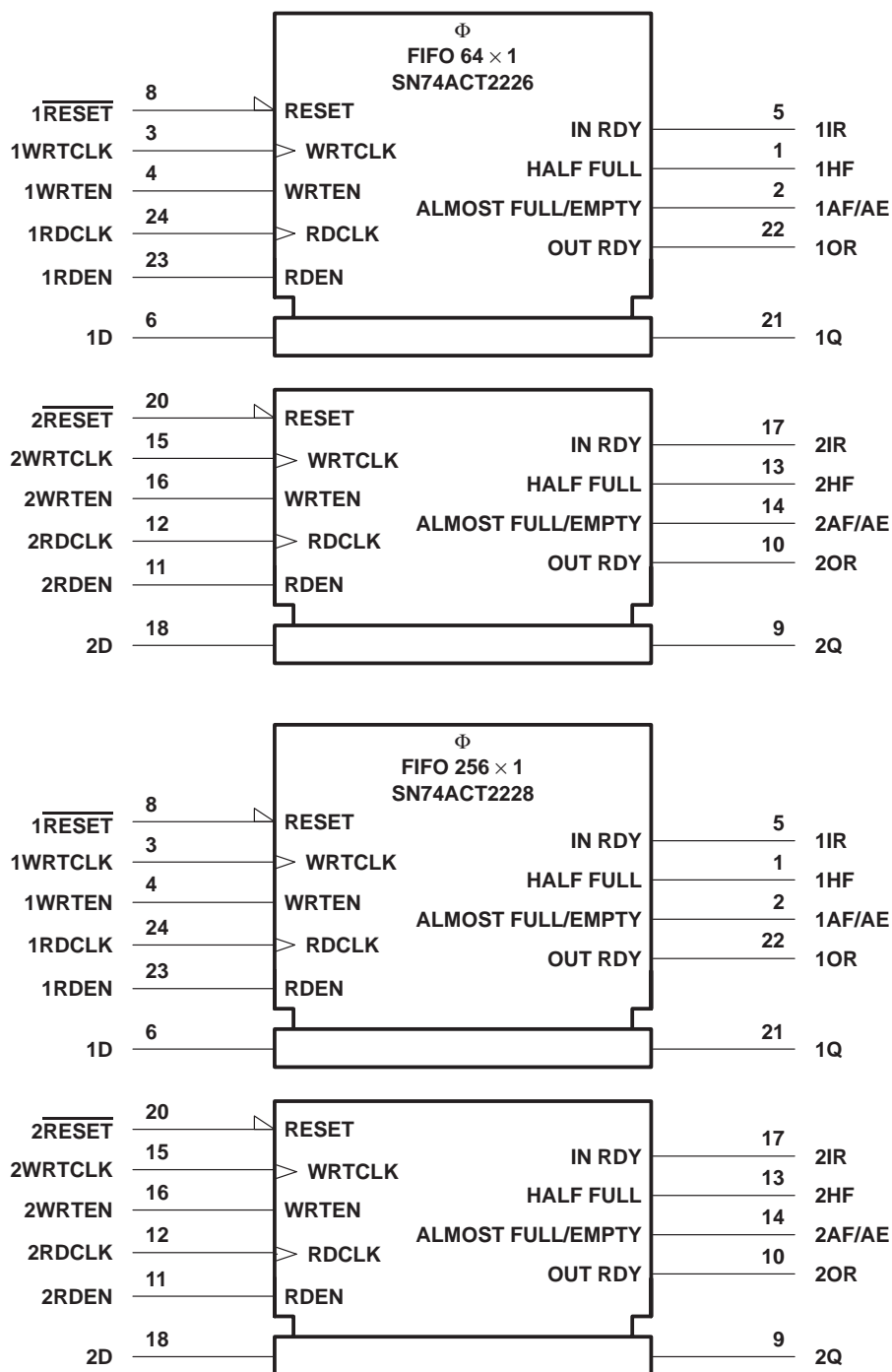

† These symbols are in accordance with ANSI/IEEE Std 91-1984 and IEC Publication 617-12.



SN74ACT2226 functional block diagram (each FIFO)

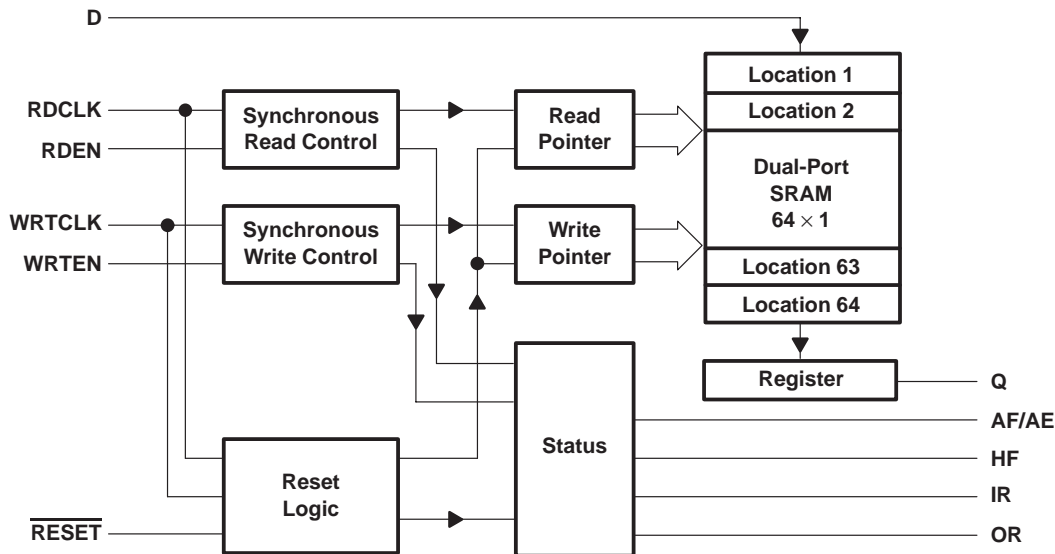

SN74ACT2228 functional block diagram (each FIFO)

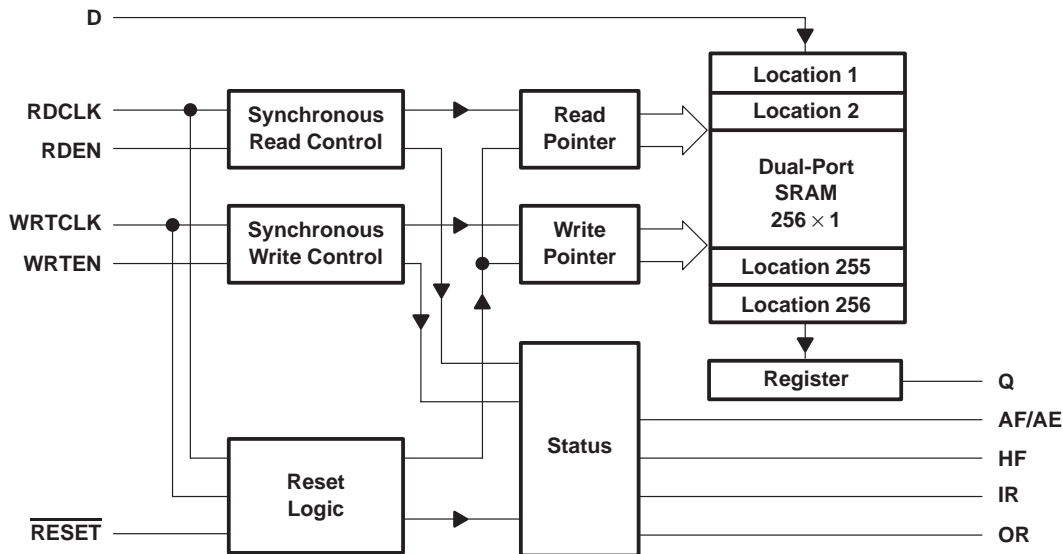

**SN74ACT2226, SN74ACT2228**  
**DUAL 64 × 1, DUAL 256 × 1**  
**CLOCKED FIRST-IN, FIRST-OUT MEMORIES**  
 SCAS219C – JUNE 1992 – REVISED OCTOBER 1997

**Terminal Functions**

TERMINAL NAME NO.		I/O	DESCRIPTION
1AF/AE 2AF/AE	2 14	O	Almost-full/almost-empty flag. AF/AE is high when the memory is eight locations or less from a full or empty state. AF/AE is set high after reset.
1D 2D	6 18	I	Data input
GND	7		Ground
1HF 2HF	1 13	O	Half-full flag. HF is high when the number of bits stored in memory is greater than or equal to half the FIFO depth. HF is set low after reset.
1IR 2IR	5 17	O	Input-ready flag. IR is synchronized to the low-to-high transition of WRTCLK. When IR is low, the FIFO is full and writes are disabled. IR is set low during reset and is set high on the second low-to-high transition of WRTCLK after reset.
1OR 2OR	22 10	O	Output-ready flag. OR is synchronized to the low-to-high transition of RDCLK. When OR is low, the FIFO is empty and reads are disabled. Ready data is present on the data output when OR is high. OR is set low during reset and set high on the third low-to-high transition of RDCLK after the first word is loaded to empty memory.
1Q 2Q	21 9	O	Data outputs. After the first valid write to empty memory, the first bit is output on the third rising edge of RDCLK. OR for the FIFO is asserted high to indicate ready data.
1RDCLK 2RDCLK	24 12	I	Read clock. RDCLK is a continuous clock and can be independent of any other clock on the device. A low-to-high transition of RDCLK reads data from memory when the FIFO RDEN and OR are high. OR is synchronous with the low-to-high transition of RDCLK.
1RDEN 2RDEN	23 11	I	Read enable. When the RDEN and OR of a FIFO are high, data is read from the FIFO on the low-to-high transition of RDCLK.
$\overline{1RESET}$ $\overline{2RESET}$	8 20	I	Reset. To reset the FIFO, four low-to-high transitions of RDCLK and four low-to-high transitions of WRTCLK must occur while $\overline{RESET}$ is low. This sets HF, IR, and OR low and AF/AE high. Before it is used, a FIFO must be reset after power up.
VCC	19		Supply voltage
1WRTCLK 2WRTCLK	3 15	I	Write clock. WRTCLK is a continuous clock and can be independent of any other clock on the device. A low-to-high transition of WRTCLK writes data to memory when WRTEEN and IR are high. IR is synchronous with the low-to-high transition of WRTCLK.
1WRTEEN 2WRTEEN	4 16	I	Write enable. When WRTEEN and IR are high, data is written to the FIFO on a low-to-high transition of WRTCLK.



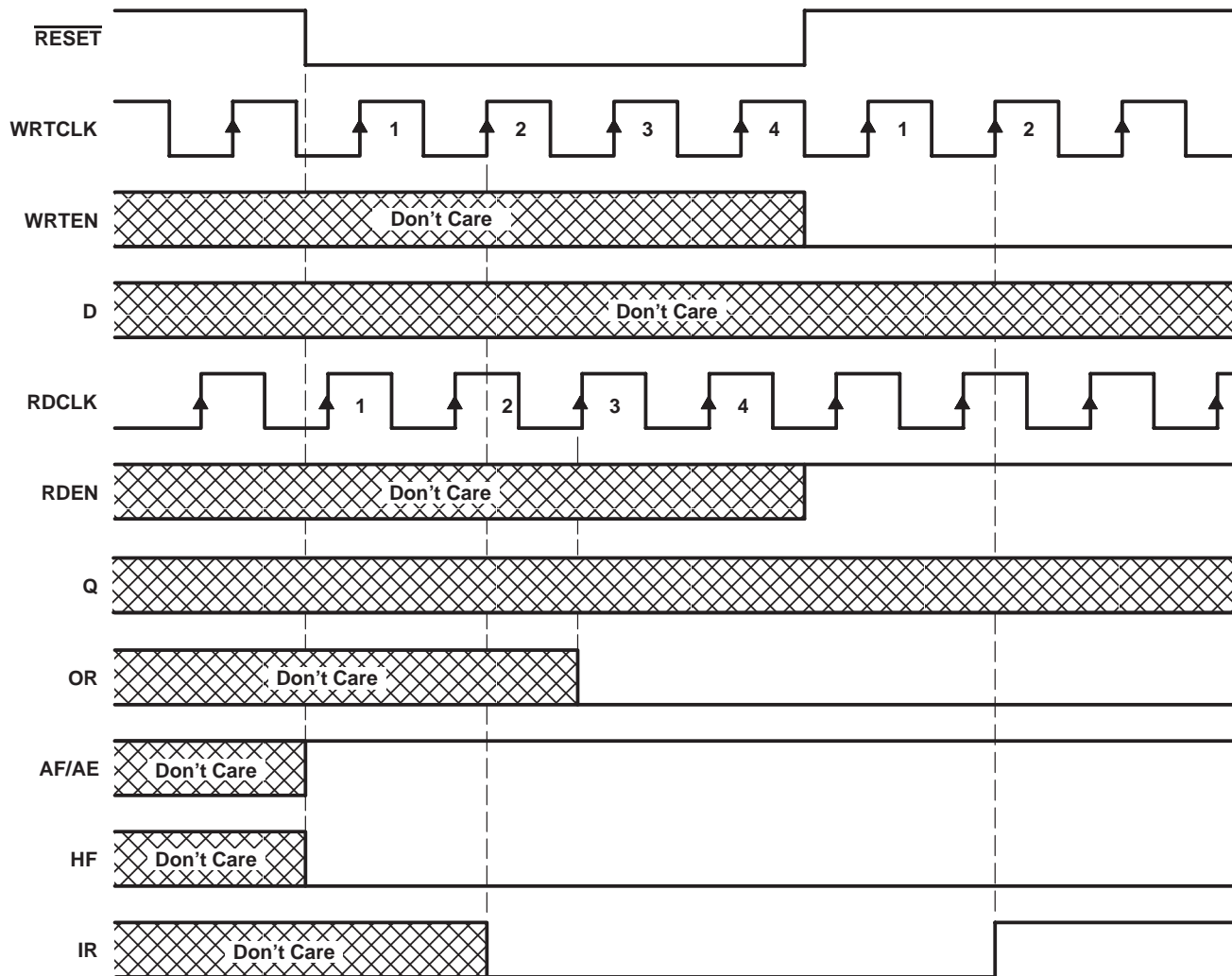
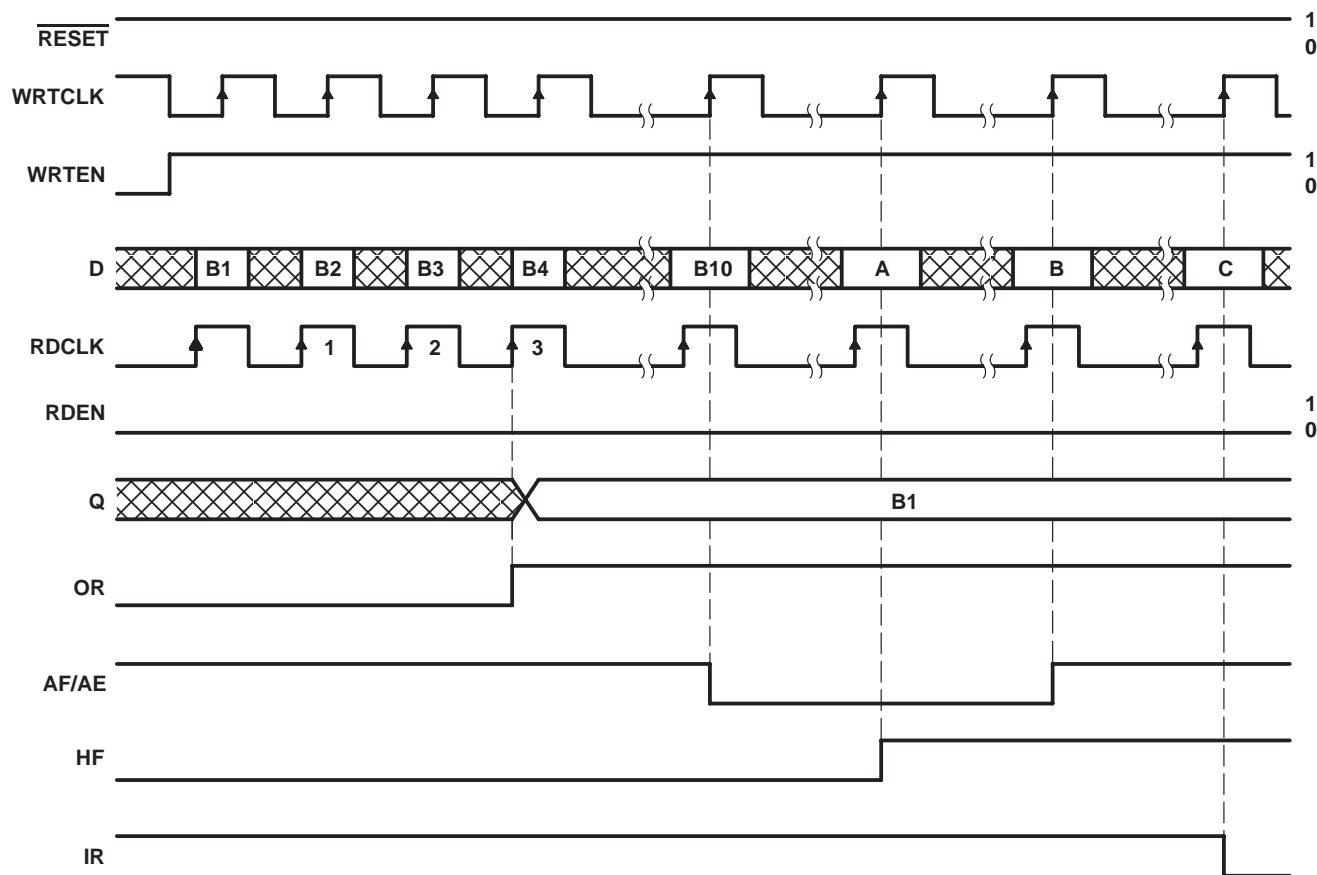

Figure 1. FIFO Reset

**SN74ACT2226, SN74ACT2228**  
**DUAL 64 × 1, DUAL 256 × 1**  
**CLOCKED FIRST-IN, FIRST-OUT MEMORIES**

SCAS219C – JUNE 1992 – REVISED OCTOBER 1997



DATA BIT NUMBER BASED ON FIFO DEPTH

DEVICE	DATA BIT		
	A	B	C
SN74ACT2226	B33	B57	B65
SN74ACT2228	B129	B249	B257

Figure 2. FIFO Write

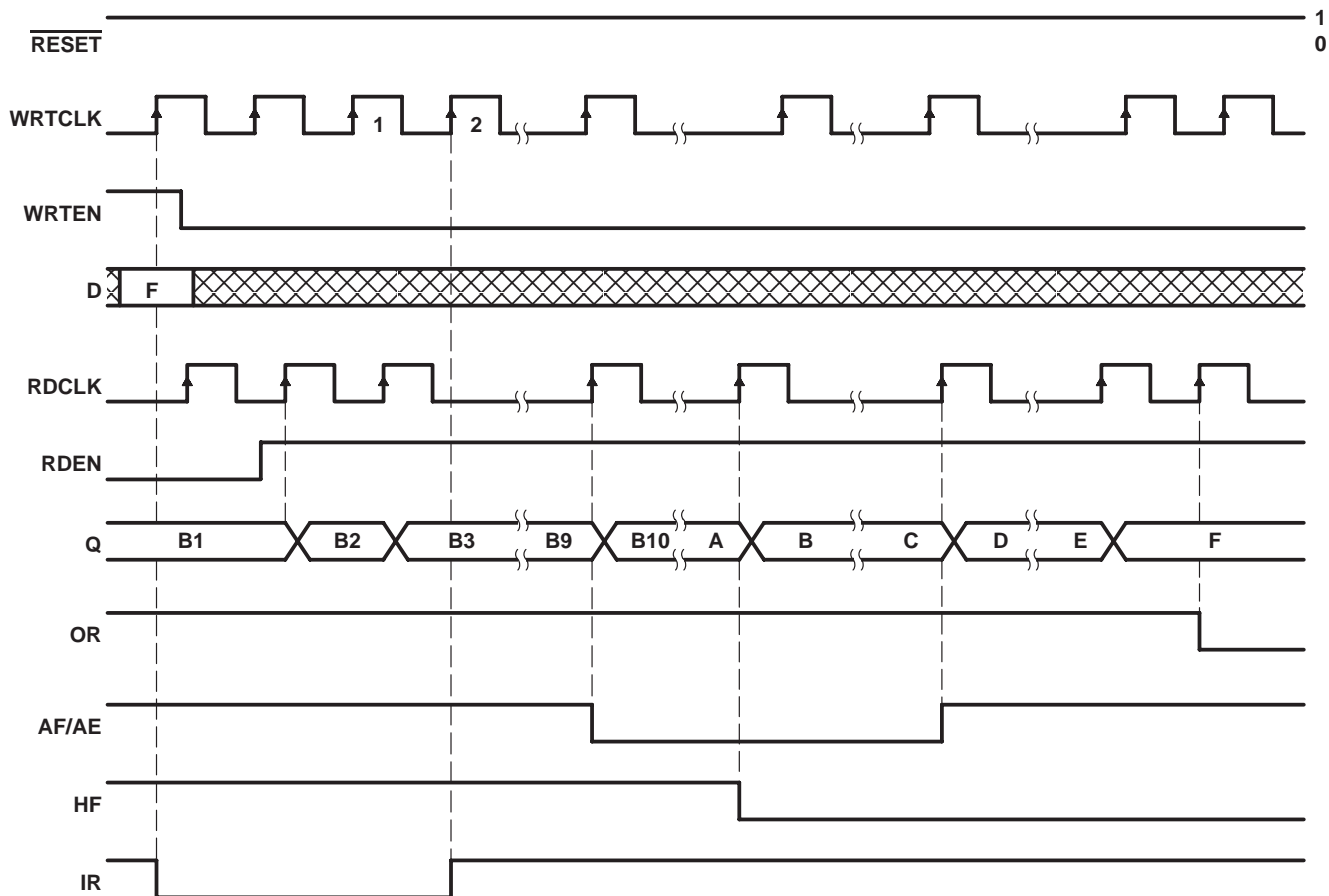

DATA BIT NUMBER BASED ON FIFO DEPTH

DEVICE	DATA BIT					
	A	B	C	D	E	F
SN74ACT2226	B33	B34	B56	B57	B64	B65
SN74ACT2228	B129	B130	B248	B249	B256	B257

Figure 3. FIFO Read

**SN74ACT2226, SN74ACT2228**  
**DUAL 64 × 1, DUAL 256 × 1**  
**CLOCKED FIRST-IN, FIRST-OUT MEMORIES**

SCAS219C – JUNE 1992 – REVISED OCTOBER 1997

**absolute maximum ratings over operating free-air temperature range (unless otherwise noted)†**

Supply voltage range, $V_{CC}$	–0.5 V to 7 V
Input voltage range, $V_I$ (see Note 1)	–0.5 V to $V_{CC} + 0.5$ V
Output voltage range, $V_O$ (see Note 1)	–0.5 V to $V_{CC} + 0.5$ V
Input clamp current, $I_{IK}$ ( $V_I < 0$ or $V_I > V_{CC}$ )	±20 mA
Output clamp current, $I_{OK}$ ( $V_O < 0$ or $V_O > V_{CC}$ )	±50 mA
Continuous output current, $I_O$ ( $V_O = 0$ to $V_{CC}$ )	±50 mA
Continuous current through $V_{CC}$ or GND	±200 mA
Package thermal impedance, $\theta_{JA}$ (see Note 2)	81°C/W
Storage temperature range, $T_{stg}$	–65°C to 150°C

† Stresses beyond those listed under “absolute maximum ratings” may cause permanent damage to the device. These are stress ratings only, and functional operation of the device at these or any other conditions beyond those indicated under “recommended operating conditions” is not implied. Exposure to absolute-maximum-rated conditions for extended periods may affect device reliability.

- NOTES: 1. The input and output voltage ratings may be exceeded provided that the input and output current ratings are observed.  
 2. The package thermal impedance is calculated in accordance with JESD 51.

**recommended operating conditions**

		MIN	MAX	UNIT
$V_{CC}$	Supply voltage	4.5	5.5	V
$V_{IH}$	High-level input voltage	2		V
$V_{IL}$	Low-level input voltage		0.8	V
$I_{OH}$	High-level output current		–8	mA
$I_{OL}$	Low-level output current	Q outputs	16	mA
		Flags	8	
$T_A$	Operating free-air temperature	–40	85	°C

**electrical characteristics over recommended operating free-air temperature range (unless otherwise noted)**

PARAMETER	TEST CONDITIONS		MIN	TYP‡	MAX	UNIT
$V_{OH}$	$V_{CC} = 4.5$ V,	$I_{OH} = -8$ mA	2.4			V
$V_{OL}$	Flags	$V_{CC} = 4.5$ V,			0.5	V
	Q outputs	$V_{CC} = 4.5$ V,			0.5	
$I_I$	$V_{CC} = 5.5$ V,	$V_I = V_{CC}$ or 0			±5	µA
$I_{OZ}$	$V_{CC} = 5.5$ V,	$V_O = V_{CC}$ or 0			±5	µA
$I_{CC}$	$V_I = V_{CC} - 0.2$ V or 0				400	µA
$\Delta I_{CC}$ §	$V_{CC} = 5.5$ V,	One input at 3.4 V, Other inputs at $V_{CC}$ or GND			1	mA
$C_i$	$V_I = 0$ ,	$f = 1$ MHz		4		pF
$C_o$	$V_O = 0$ ,	$f = 1$ MHz		8		pF

‡ All typical values are at  $V_{CC} = 5$  V,  $T_A = 25^\circ\text{C}$ .

§ This is the supply current when each input is at one of the specified TTL voltage levels rather than 0 V or  $V_{CC}$ .



**timing requirements over recommended ranges of supply voltage and operating free-air temperature (unless otherwise noted) (see Figures 1 through 3)**

			MIN	MAX	UNIT
$f_{\text{clock}}$	Clock frequency			22	MHz
$t_w$	Pulse duration	1WRTCLK, 2WRTCLK high or low	15		ns
		1RDCLK, 2RDCLK high or low	15		
$t_{\text{su}}$	Setup time	1D before 1WRTCLK $\uparrow$ and 2D before 2WRTCLK $\uparrow$	6		ns
		1WRTEN before 1WRTCLK $\uparrow$ and 2WRTEN before 2WRTCLK $\uparrow$	6		
		1RDEN before 1RDCLK $\uparrow$ and 2RDEN before 2RDCLK $\uparrow$	6		
		1RESE $\overline{T}$ low before 1WRTCLK $\uparrow$ and 2RESE $\overline{T}$ low before 2WRTCLK $\uparrow$ $\dagger$	6		
		1RESE $\overline{T}$ low before 1RDCLK $\uparrow$ and 2RESE $\overline{T}$ low before 2RDCLK $\uparrow$ $\dagger$	6		
$t_h$	Hold time	1D after 1WRTCLK $\uparrow$ and 2D after 2WRTCLK $\uparrow$	0		ns
		1WRTEN after 1WRTCLK $\uparrow$ and 2WRTEN after 2WRTCLK $\uparrow$	0		
		1RDEN after 1RDCLK $\uparrow$ and 2RDEN after 2RDCLK $\uparrow$	0		
		1RESE $\overline{T}$ low after 1WRTCLK $\uparrow$ and 2RESE $\overline{T}$ low after 2WRTCLK $\uparrow$ $\dagger$	6		
		1RESE $\overline{T}$ low after 1RDCLK $\uparrow$ and 2RESE $\overline{T}$ low after 2RDCLK $\uparrow$ $\dagger$	6		

$\dagger$  Requirement to count the clock edge as one of at least four needed to reset a FIFO

**switching characteristics over recommended ranges of supply voltage and operating free-air temperature,  $C_L = 50$  pF (unless otherwise noted) (see Figure 4)**

PARAMETER	FROM (INPUT)	TO (OUTPUT)	MIN	MAX	UNIT
$f_{\text{max}}$	1WRTCLK, 2WRTCLK, or 1RDCLK, 2RDCLK		22		MHz
$t_{\text{pd}}$	1RDCLK $\uparrow$ , 2RDCLK $\uparrow$	1Q, 2Q	2	20	ns
	1WRTCLK $\uparrow$ , 2WRTCLK $\uparrow$	1IR, 2IR	1	20	
	1RDCLK $\uparrow$ , 2RDCLK $\uparrow$	1OR, 2OR	1	20	
	1WRTCLK $\uparrow$ , 2WRTCLK $\uparrow$	1AF/AE, 2AF/AE	3	20	
	1RDCLK $\uparrow$ , 2RDCLK $\uparrow$		3	20	
$t_{\text{PLH}}$	1WRTCLK $\uparrow$ , 2WRTCLK $\uparrow$	1HF, 2HF	2	20	ns
$t_{\text{PHL}}$	1RDCLK $\uparrow$ , 2RDCLK $\uparrow$		3	20	
$t_{\text{PLH}}$	1RESE $\overline{T}$ , 2RESE $\overline{T}$ low	1AF/AE, 2AF/AE	1	20	ns
$t_{\text{PHL}}$		1HF, 2HF	1	20	

PARAMETER MEASUREMENT INFORMATION

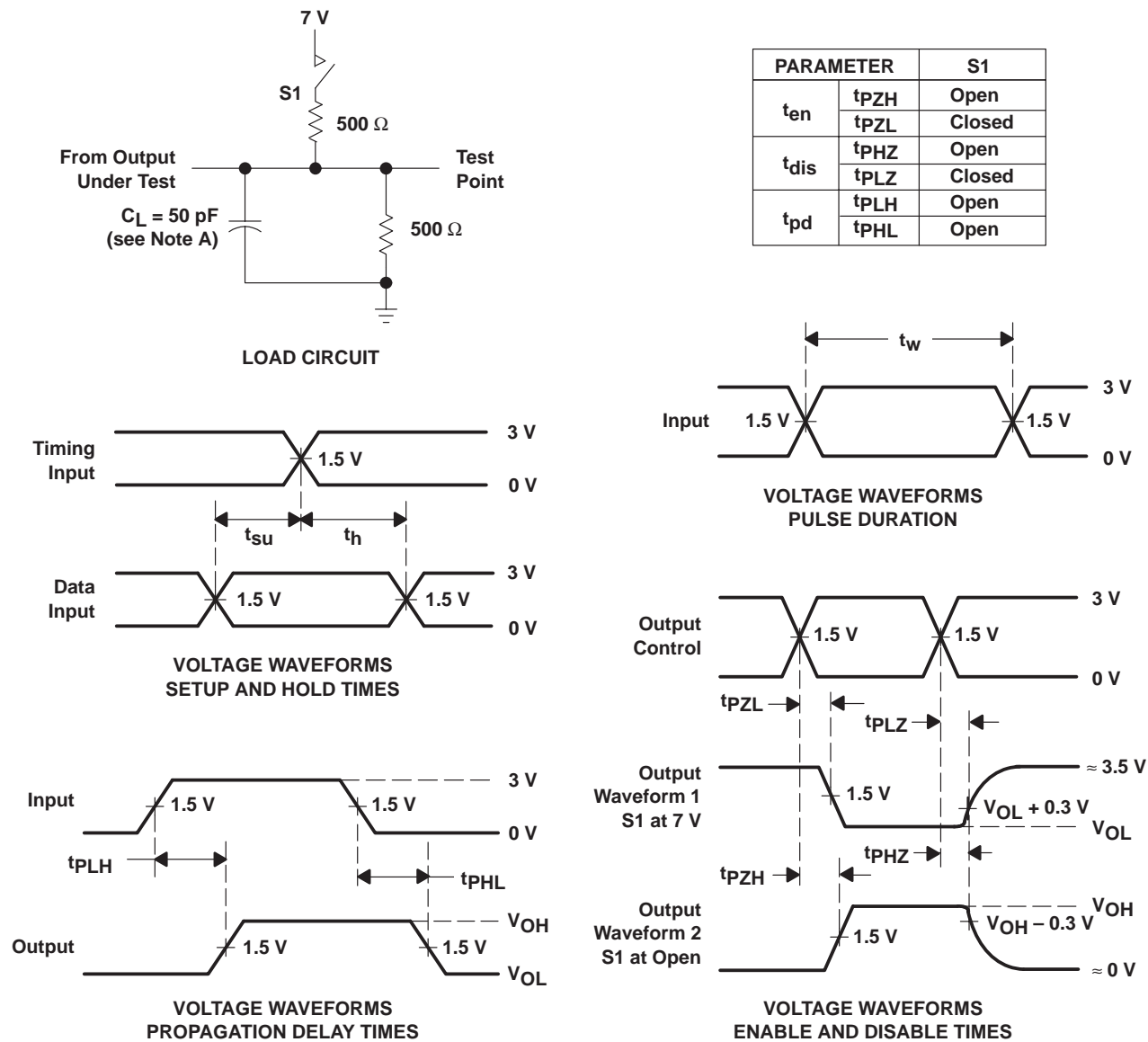

NOTE A:  $C_L$  includes probe and jig capacitance.

Figure 4. Load Circuit and Voltage Waveforms

TYPICAL CHARACTERISTICS

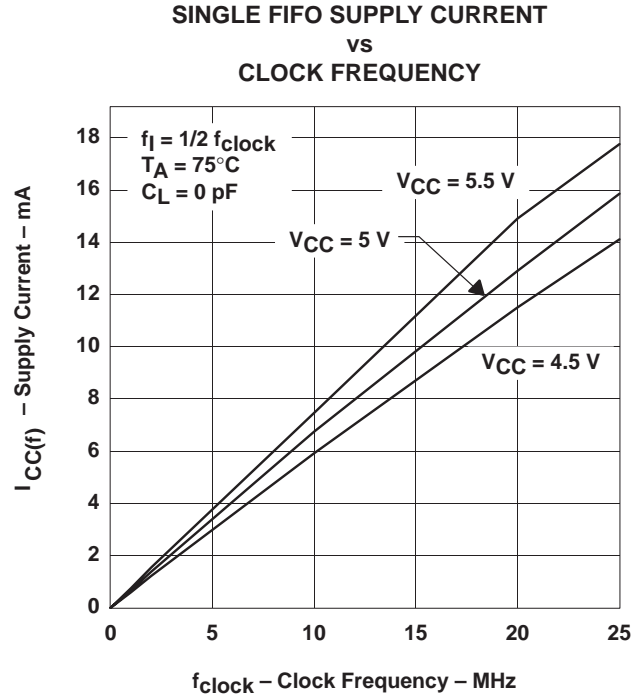

Figure 5

calculating power dissipation

Data for Figure 5 is taken with one FIFO active and one FIFO idle on the device. The active FIFO has both writes and reads enabled with its read clock (RDCLK) and write clock (WRTCLK) operating at the rate specified by  $f_{\text{clock}}$ . The data input rate and data output rate are half the  $f_{\text{clock}}$  rate, and the data output is disconnected. A close approximation of the total device power can be found by using Figure 5, determining the capacitive load on the data output and determining the number of SN74ACT2226/2228 inputs driven by TTL high levels.

With  $I_{\text{CC}(f)}$  taken from Figure 5, the maximum power dissipation ( $P_T$ ) of one FIFO on the SN74ACT2226 or SN74ACT2228 can be calculated by:

$$P_T = V_{\text{CC}} \times [I_{\text{CC}(f)} + (N \times \Delta I_{\text{CC}} \times \text{dc})] + (C_L \times V_{\text{CC}}^2 \times f_o)$$

where:

- N = number of inputs driven by TTL levels
- $\Delta I_{\text{CC}}$  = increase in power-supply current for each input at a TTL high level
- dc = duty cycle of inputs at a TTL high level of 3.4 V
- $C_L$  = output capacitive load
- $f_o$  = switching frequency of an output

**APPLICATION INFORMATION**

An example of concentrating two independent serial-data signals into a single composite data signal with the use of an SN74ACT2226 or SN74ACT2228 device is shown in Figure 6. The input data to the FIFOs share the same average (mean) frequency and the mean frequency of the SYS\_CLOCK is greater than or equal to the sum of the individual mean input rates. A single-bit FIFO is needed for each additional input data signal that is time-division multiplexed into the composite signal.

The FIFO memories provide a buffer to absorb clock jitter generated by the transmission systems of incoming signals and synchronize the phase-independent inputs to one another. FIFO half-full (HF) flags are used to signal the multiplexer to start fetching data from the buffers. The state of the flags also can be used to indicate when a FIFO read should be suppressed to regulate the output flow (pulse-stuffing control). The FIFO almost-full/almost-empty (AF/AE) flags can be used in place of the half-full flags to reduce transmission delay.

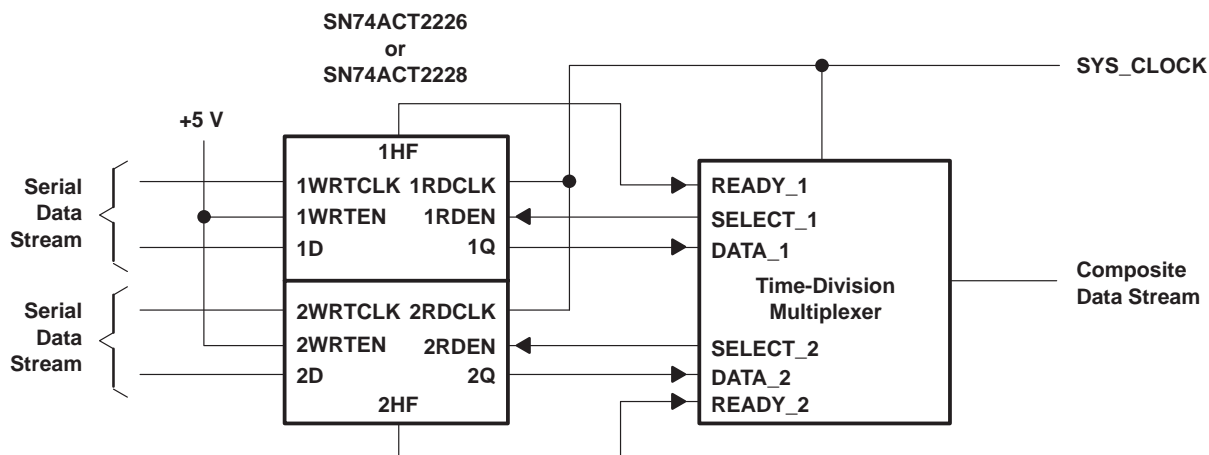

**Figure 6. Time-Division Multiplexing Using the SN74ACT2226 or SN74ACT2228**

**PACKAGING INFORMATION**

Orderable Device	Status <sup>(1)</sup>	Package Type	Package Drawing	Pins	Package Qty	Eco Plan <sup>(2)</sup>	Lead/Ball Finish	MSL Peak Temp <sup>(3)</sup>
SN74ACT2226DW	ACTIVE	SOIC	DW	24	25	Green (RoHS & no Sb/Br)	CU NIPDAU	Level-1-260C-UNLIM
SN74ACT2226DWR	ACTIVE	SOIC	DW	24	2000	Green (RoHS & no Sb/Br)	CU NIPDAU	Level-1-260C-UNLIM
SN74ACT2228DW	ACTIVE	SOIC	DW	24	25	Green (RoHS & no Sb/Br)	CU NIPDAU	Level-1-260C-UNLIM
SN74ACT2228DWR	ACTIVE	SOIC	DW	24	2000	Green (RoHS & no Sb/Br)	CU NIPDAU	Level-1-260C-UNLIM

<sup>(1)</sup> The marketing status values are defined as follows:

**ACTIVE:** Product device recommended for new designs.

**LIFEBUY:** TI has announced that the device will be discontinued, and a lifetime-buy period is in effect.

**NRND:** Not recommended for new designs. Device is in production to support existing customers, but TI does not recommend using this part in a new design.

**PREVIEW:** Device has been announced but is not in production. Samples may or may not be available.

**OBSOLETE:** TI has discontinued the production of the device.

<sup>(2)</sup> Eco Plan - The planned eco-friendly classification: Pb-Free (RoHS), Pb-Free (RoHS Exempt), or Green (RoHS & no Sb/Br) - please check <http://www.ti.com/productcontent> for the latest availability information and additional product content details.

**TBD:** The Pb-Free/Green conversion plan has not been defined.

**Pb-Free (RoHS):** TI's terms "Lead-Free" or "Pb-Free" mean semiconductor products that are compatible with the current RoHS requirements for all 6 substances, including the requirement that lead not exceed 0.1% by weight in homogeneous materials. Where designed to be soldered at high temperatures, TI Pb-Free products are suitable for use in specified lead-free processes.

**Pb-Free (RoHS Exempt):** This component has a RoHS exemption for either 1) lead-based flip-chip solder bumps used between the die and package, or 2) lead-based die adhesive used between the die and leadframe. The component is otherwise considered Pb-Free (RoHS compatible) as defined above.

**Green (RoHS & no Sb/Br):** TI defines "Green" to mean Pb-Free (RoHS compatible), and free of Bromine (Br) and Antimony (Sb) based flame retardants (Br or Sb do not exceed 0.1% by weight in homogeneous material)

<sup>(3)</sup> MSL, Peak Temp. -- The Moisture Sensitivity Level rating according to the JEDEC industry standard classifications, and peak solder temperature.

**Important Information and Disclaimer:**The information provided on this page represents TI's knowledge and belief as of the date that it is provided. TI bases its knowledge and belief on information provided by third parties, and makes no representation or warranty as to the accuracy of such information. Efforts are underway to better integrate information from third parties. TI has taken and continues to take reasonable steps to provide representative and accurate information but may not have conducted destructive testing or chemical analysis on incoming materials and chemicals. TI and TI suppliers consider certain information to be proprietary, and thus CAS numbers and other limited information may not be available for release.

In no event shall TI's liability arising out of such information exceed the total purchase price of the TI part(s) at issue in this document sold by TI to Customer on an annual basis.

**TAPE AND REEL INFORMATION**

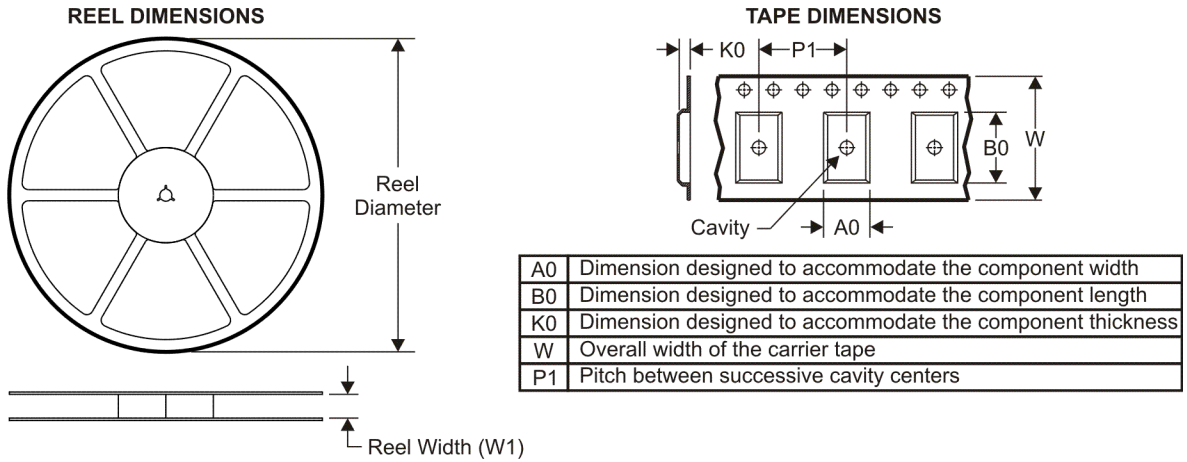

**QUADRANT ASSIGNMENTS FOR PIN 1 ORIENTATION IN TAPE**

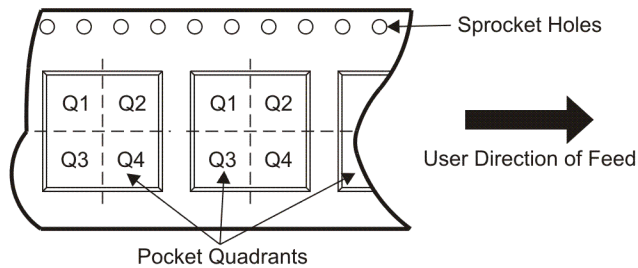

\*All dimensions are nominal

Device	Package Type	Package Drawing	Pins	SPQ	Reel Diameter (mm)	Reel Width W1 (mm)	A0 (mm)	B0 (mm)	K0 (mm)	P1 (mm)	W (mm)	Pin1 Quadrant
SN74ACT2226DWR	SOIC	DW	24	2000	330.0	24.4	10.75	15.7	2.7	12.0	24.0	Q1
SN74ACT2228DWR	SOIC	DW	24	2000	330.0	24.4	10.75	15.7	2.7	12.0	24.0	Q1

**TAPE AND REEL BOX DIMENSIONS**

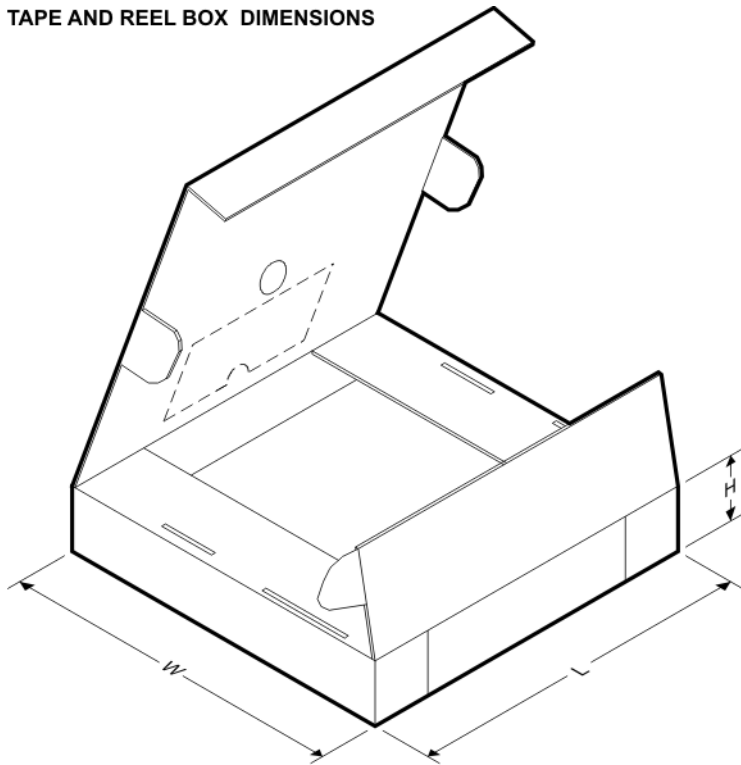

\*All dimensions are nominal

Device	Package Type	Package Drawing	Pins	SPQ	Length (mm)	Width (mm)	Height (mm)
SN74ACT2226DWR	SOIC	DW	24	2000	346.0	346.0	41.0
SN74ACT2228DWR	SOIC	DW	24	2000	346.0	346.0	41.0

DW (R-PDSO-G24)

PLASTIC SMALL-OUTLINE PACKAGE

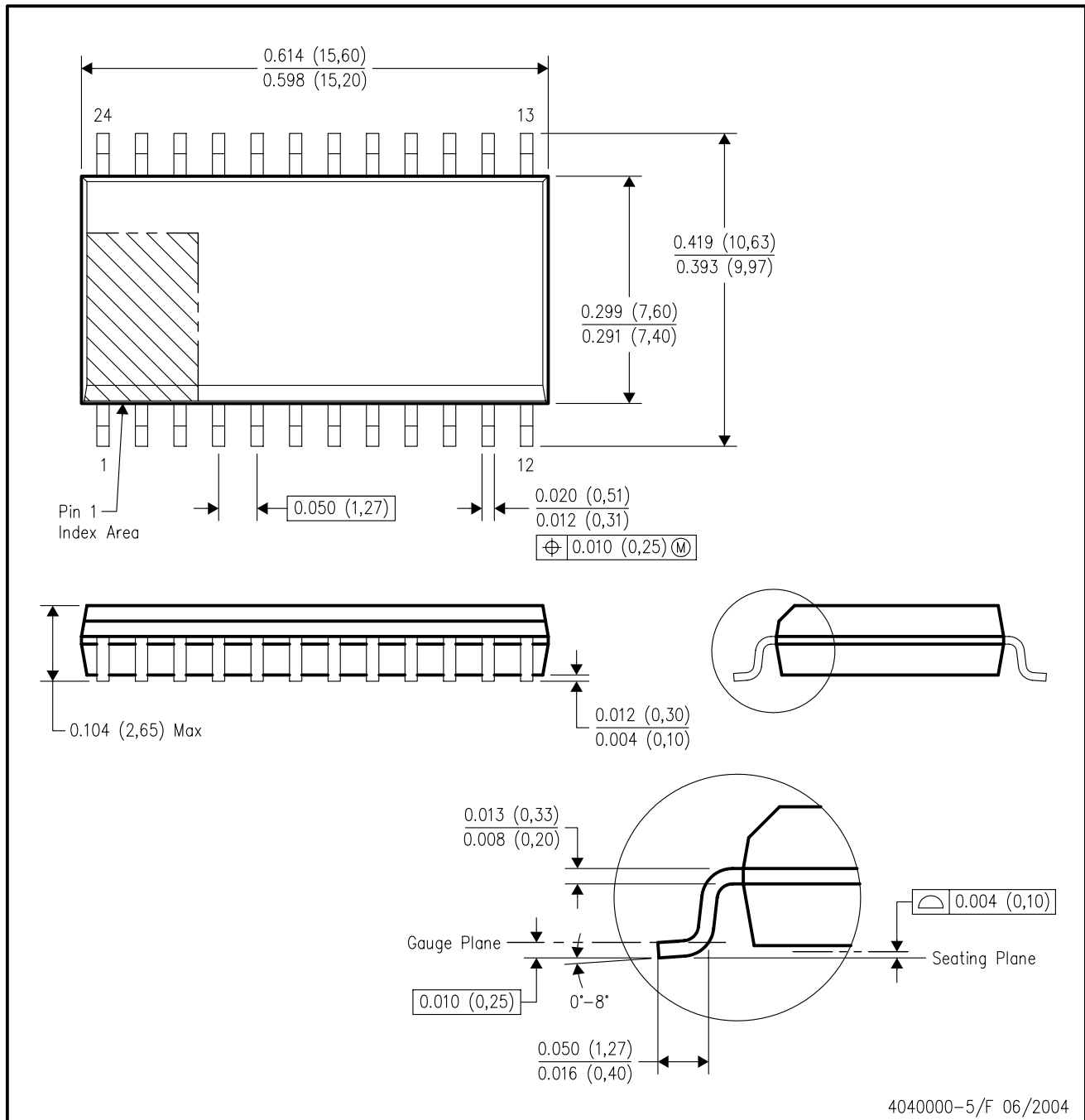

- NOTES:
- A. All linear dimensions are in inches (millimeters).
  - B. This drawing is subject to change without notice.
  - C. Body dimensions do not include mold flash or protrusion not to exceed 0.006 (0,15).
  - D. Falls within JEDEC MS-013 variation AD.

**PACKAGING INFORMATION**

Orderable Device	Status <sup>(1)</sup>	Package Type	Package Drawing	Pins	Package Qty	Eco Plan <sup>(2)</sup>	Lead/Ball Finish	MSL Peak Temp <sup>(3)</sup>
SN74ACT2226DW	ACTIVE	SOIC	DW	24	25	Green (RoHS & no Sb/Br)	CU NIPDAU	Level-1-260C-UNLIM
SN74ACT2226DWR	ACTIVE	SOIC	DW	24	2000	Green (RoHS & no Sb/Br)	CU NIPDAU	Level-1-260C-UNLIM
SN74ACT2228DW	ACTIVE	SOIC	DW	24	25	Green (RoHS & no Sb/Br)	CU NIPDAU	Level-1-260C-UNLIM
SN74ACT2228DWR	ACTIVE	SOIC	DW	24	2000	Green (RoHS & no Sb/Br)	CU NIPDAU	Level-1-260C-UNLIM

<sup>(1)</sup> The marketing status values are defined as follows:

**ACTIVE:** Product device recommended for new designs.

**LIFEBUY:** TI has announced that the device will be discontinued, and a lifetime-buy period is in effect.

**NRND:** Not recommended for new designs. Device is in production to support existing customers, but TI does not recommend using this part in a new design.

**PREVIEW:** Device has been announced but is not in production. Samples may or may not be available.

**OBSOLETE:** TI has discontinued the production of the device.

<sup>(2)</sup> Eco Plan - The planned eco-friendly classification: Pb-Free (RoHS), Pb-Free (RoHS Exempt), or Green (RoHS & no Sb/Br) - please check <http://www.ti.com/productcontent> for the latest availability information and additional product content details.

**TBD:** The Pb-Free/Green conversion plan has not been defined.

**Pb-Free (RoHS):** TI's terms "Lead-Free" or "Pb-Free" mean semiconductor products that are compatible with the current RoHS requirements for all 6 substances, including the requirement that lead not exceed 0.1% by weight in homogeneous materials. Where designed to be soldered at high temperatures, TI Pb-Free products are suitable for use in specified lead-free processes.

**Pb-Free (RoHS Exempt):** This component has a RoHS exemption for either 1) lead-based flip-chip solder bumps used between the die and package, or 2) lead-based die adhesive used between the die and leadframe. The component is otherwise considered Pb-Free (RoHS compatible) as defined above.

**Green (RoHS & no Sb/Br):** TI defines "Green" to mean Pb-Free (RoHS compatible), and free of Bromine (Br) and Antimony (Sb) based flame retardants (Br or Sb do not exceed 0.1% by weight in homogeneous material)

<sup>(3)</sup> MSL, Peak Temp. -- The Moisture Sensitivity Level rating according to the JEDEC industry standard classifications, and peak solder temperature.

**Important Information and Disclaimer:**The information provided on this page represents TI's knowledge and belief as of the date that it is provided. TI bases its knowledge and belief on information provided by third parties, and makes no representation or warranty as to the accuracy of such information. Efforts are underway to better integrate information from third parties. TI has taken and continues to take reasonable steps to provide representative and accurate information but may not have conducted destructive testing or chemical analysis on incoming materials and chemicals. TI and TI suppliers consider certain information to be proprietary, and thus CAS numbers and other limited information may not be available for release.

In no event shall TI's liability arising out of such information exceed the total purchase price of the TI part(s) at issue in this document sold by TI to Customer on an annual basis.

**TAPE AND REEL INFORMATION**
**REEL DIMENSIONS**

**TAPE DIMENSIONS**

A0	Dimension designed to accommodate the component width
B0	Dimension designed to accommodate the component length
K0	Dimension designed to accommodate the component thickness
W	Overall width of the carrier tape
P1	Pitch between successive cavity centers

**TAPE AND REEL INFORMATION**

\*All dimensions are nominal

Device	Package Type	Package Drawing	Pins	SPQ	Reel Diameter (mm)	Reel Width W1 (mm)	A0 (mm)	B0 (mm)	K0 (mm)	P1 (mm)	W (mm)	Pin1 Quadrant
SN74ACT2226DWR	SOIC	DW	24	2000	330.0	24.4	10.75	15.7	2.7	12.0	24.0	Q1
SN74ACT2228DWR	SOIC	DW	24	2000	330.0	24.4	10.75	15.7	2.7	12.0	24.0	Q1

**TAPE AND REEL BOX DIMENSIONS**

\*All dimensions are nominal

Device	Package Type	Package Drawing	Pins	SPQ	Length (mm)	Width (mm)	Height (mm)
SN74ACT2226DWR	SOIC	DW	24	2000	367.0	367.0	45.0
SN74ACT2228DWR	SOIC	DW	24	2000	367.0	367.0	45.0

DW (R-PDSO-G24)

PLASTIC SMALL OUTLINE

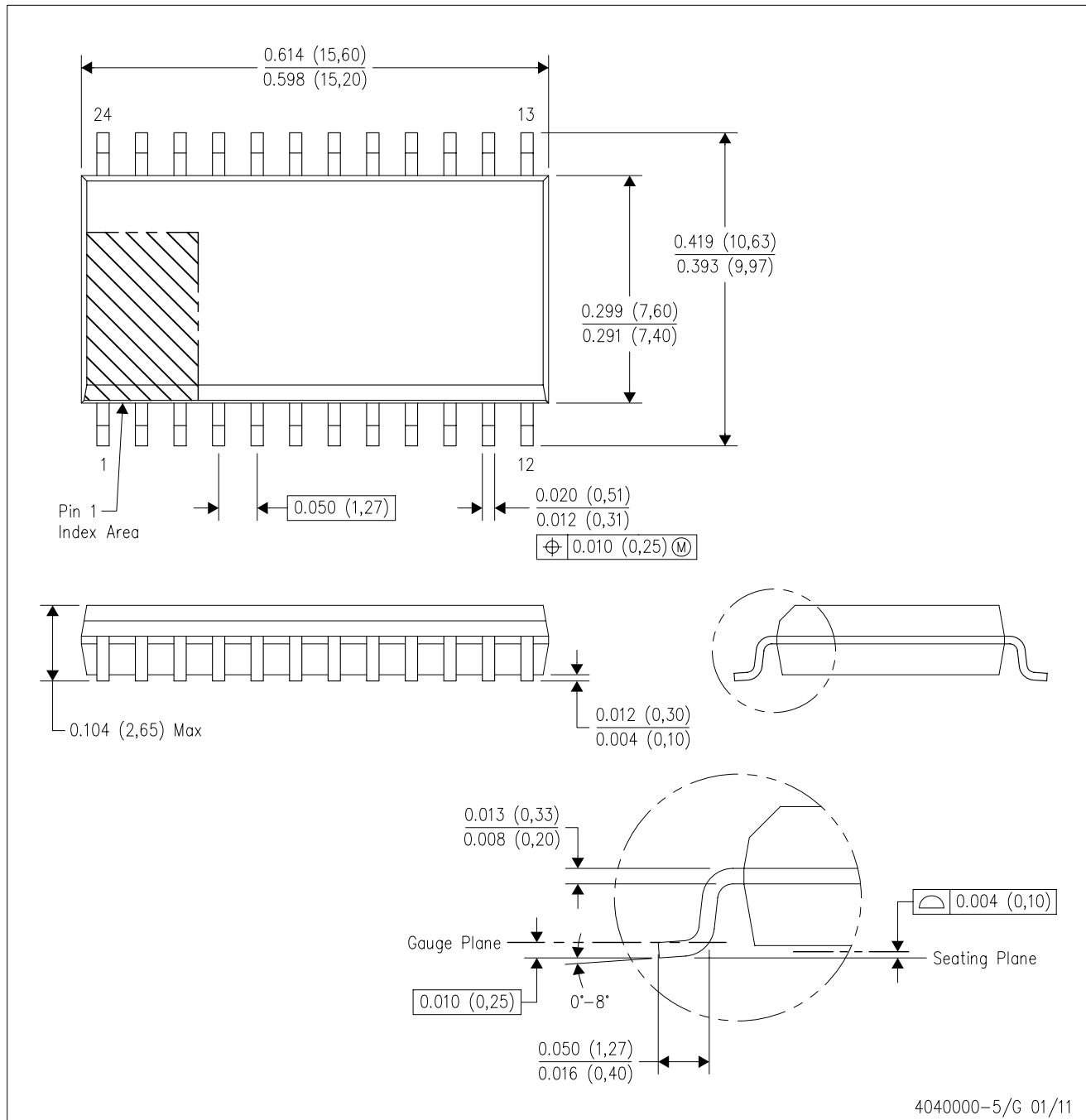

- NOTES:
- A. All linear dimensions are in inches (millimeters). Dimensioning and tolerancing per ASME Y14.5M-1994.
  - B. This drawing is subject to change without notice.
  - C. Body dimensions do not include mold flash or protrusion not to exceed 0.006 (0,15).
  - D. Falls within JEDEC MS-013 variation AD.

## IMPORTANT NOTICE

Texas Instruments Incorporated and its subsidiaries (TI) reserve the right to make corrections, enhancements, improvements and other changes to its semiconductor products and services per JESD46C and to discontinue any product or service per JESD48B. Buyers should obtain the latest relevant information before placing orders and should verify that such information is current and complete. All semiconductor products (also referred to herein as "components") are sold subject to TI's terms and conditions of sale supplied at the time of order acknowledgment.

TI warrants performance of its components to the specifications applicable at the time of sale, in accordance with the warranty in TI's terms and conditions of sale of semiconductor products. Testing and other quality control techniques are used to the extent TI deems necessary to support this warranty. Except where mandated by applicable law, testing of all parameters of each component is not necessarily performed.

TI assumes no liability for applications assistance or the design of Buyers' products. Buyers are responsible for their products and applications using TI components. To minimize the risks associated with Buyers' products and applications, Buyers should provide adequate design and operating safeguards.

TI does not warrant or represent that any license, either express or implied, is granted under any patent right, copyright, mask work right, or other intellectual property right relating to any combination, machine, or process in which TI components or services are used. Information published by TI regarding third-party products or services does not constitute a license to use such products or services or a warranty or endorsement thereof. Use of such information may require a license from a third party under the patents or other intellectual property of the third party, or a license from TI under the patents or other intellectual property of TI.

Reproduction of significant portions of TI information in TI data books or data sheets is permissible only if reproduction is without alteration and is accompanied by all associated warranties, conditions, limitations, and notices. TI is not responsible or liable for such altered documentation. Information of third parties may be subject to additional restrictions.

Resale of TI components or services with statements different from or beyond the parameters stated by TI for that component or service voids all express and any implied warranties for the associated TI component or service and is an unfair and deceptive business practice. TI is not responsible or liable for any such statements.

Buyer acknowledges and agrees that it is solely responsible for compliance with all legal, regulatory and safety-related requirements concerning its products, and any use of TI components in its applications, notwithstanding any applications-related information or support that may be provided by TI. Buyer represents and agrees that it has all the necessary expertise to create and implement safeguards which anticipate dangerous consequences of failures, monitor failures and their consequences, lessen the likelihood of failures that might cause harm and take appropriate remedial actions. Buyer will fully indemnify TI and its representatives against any damages arising out of the use of any TI components in safety-critical applications.

In some cases, TI components may be promoted specifically to facilitate safety-related applications. With such components, TI's goal is to help enable customers to design and create their own end-product solutions that meet applicable functional safety standards and requirements. Nonetheless, such components are subject to these terms.

No TI components are authorized for use in FDA Class III (or similar life-critical medical equipment) unless authorized officers of the parties have executed a special agreement specifically governing such use.

Only those TI components which TI has specifically designated as military grade or "enhanced plastic" are designed and intended for use in military/aerospace applications or environments. Buyer acknowledges and agrees that any military or aerospace use of TI components which have **not** been so designated is solely at the Buyer's risk, and that Buyer is solely responsible for compliance with all legal and regulatory requirements in connection with such use.

TI has specifically designated certain components which meet ISO/TS16949 requirements, mainly for automotive use. Components which have not been so designated are neither designed nor intended for automotive use; and TI will not be responsible for any failure of such components to meet such requirements.

### Products

Audio	<a href="http://www.ti.com/audio">www.ti.com/audio</a>
Amplifiers	<a href="http://amplifier.ti.com">amplifier.ti.com</a>
Data Converters	<a href="http://dataconverter.ti.com">dataconverter.ti.com</a>
DLP® Products	<a href="http://www.dlp.com">www.dlp.com</a>
DSP	<a href="http://dsp.ti.com">dsp.ti.com</a>
Clocks and Timers	<a href="http://www.ti.com/clocks">www.ti.com/clocks</a>
Interface	<a href="http://interface.ti.com">interface.ti.com</a>
Logic	<a href="http://logic.ti.com">logic.ti.com</a>
Power Mgmt	<a href="http://power.ti.com">power.ti.com</a>
Microcontrollers	<a href="http://microcontroller.ti.com">microcontroller.ti.com</a>
RFID	<a href="http://www.ti-rfid.com">www.ti-rfid.com</a>
OMAP Mobile Processors	<a href="http://www.ti.com/omap">www.ti.com/omap</a>
Wireless Connectivity	<a href="http://www.ti.com/wirelessconnectivity">www.ti.com/wirelessconnectivity</a>

### Applications

Automotive and Transportation	<a href="http://www.ti.com/automotive">www.ti.com/automotive</a>
Communications and Telecom	<a href="http://www.ti.com/communications">www.ti.com/communications</a>
Computers and Peripherals	<a href="http://www.ti.com/computers">www.ti.com/computers</a>
Consumer Electronics	<a href="http://www.ti.com/consumer-apps">www.ti.com/consumer-apps</a>
Energy and Lighting	<a href="http://www.ti.com/energy">www.ti.com/energy</a>
Industrial	<a href="http://www.ti.com/industrial">www.ti.com/industrial</a>
Medical	<a href="http://www.ti.com/medical">www.ti.com/medical</a>
Security	<a href="http://www.ti.com/security">www.ti.com/security</a>
Space, Avionics and Defense	<a href="http://www.ti.com/space-avionics-defense">www.ti.com/space-avionics-defense</a>
Video and Imaging	<a href="http://www.ti.com/video">www.ti.com/video</a>

**TI E2E Community** [e2e.ti.com](http://e2e.ti.com)