

Distributed by:

JAMECO[®]
ELECTRONICS

www.Jameco.com ♦ 1-800-831-4242

The content and copyrights of the attached
material are the property of its owner.

Jameco Part Number 1998802

SN54ABTH25245, SN74ABTH25245 25-Ω OCTAL BUS TRANSCEIVERS WITH 3-STATE OUTPUTS

SCBS251F - JUNE 1992 - REVISED MAY 1997

- State-of-the-Art EPIC-II^B™ BiCMOS Design Significantly Reduces Power Dissipation
- ESD Protection Exceeds 2000 V Per MIL-STD-883, Method 3015; Exceeds 200 V Using Machine Model (C = 200 pF, R = 0)
- Latch-Up Performance Exceeds 500 mA Per JEDEC Standard JESD-17
- Typical V_{OLP} (Output Ground Bounce) < 1 V at $V_{CC} = 5$ V, $T_A = 25^\circ\text{C}$
- High-Impedance State During Power Up and Power Down
- Designed to Facilitate Incident-Wave Switching for Line Impedances of 25 Ω or Greater
- Distributed V_{CC} and GND Pin Configuration Minimizes High-Speed Switching Noise
- Bus Hold on Data Inputs Eliminates the Need for External Pullup/Pulldown Resistors
- Package Options Include Plastic Small-Outline (DW) Package, Ceramic Chip Carriers (FK), and Standard Plastic (NT) and Ceramic (JT) DIPs

description

The 'ABTH25245 are 25-Ω octal bus transceivers designed for asynchronous communication between data buses. They improve both the performance and density of 3-state memory address drivers, clock drivers, and bus-oriented transceivers.

These devices allow noninverted data transmission from the A bus to the B bus or from the B bus to the A bus, depending on the logic level at the direction-control (DIR) input. The output-enable (\overline{OE}) input can disable the device so that both buses are effectively isolated. When \overline{OE} is low, the device is active.

These transceivers are capable of sinking 188 mA of I_{OL} current, which facilitates switching 25-Ω transmission lines on the incident wave. The distributed V_{CC} and GND pins minimize switching noise for more-reliable system operation.

Active bus-hold circuitry is provided to hold unused or floating data inputs at a valid logic level.

SN54ABTH25245 ... JT PACKAGE
SN74ABTH25245 ... DW OR NT PACKAGE
(TOP VIEW)

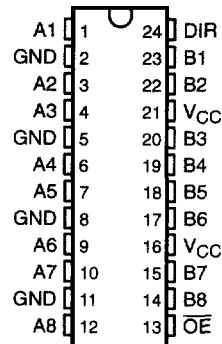

SN54ABTH25245 ... FK PACKAGE
(TOP VIEW)

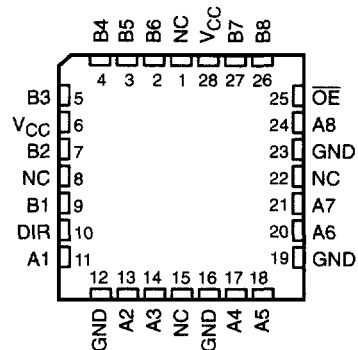

NC - No internal connection

EPIC-II^B is a trademark of Texas Instruments Incorporated.

UNLESS OTHERWISE NOTED this document contains PRODUCTION DATA information current as of publication date. Products conform to specifications per the terms of Texas Instruments standard warranty. Production processing does not necessarily include testing of all parameters.

 **TEXAS
INSTRUMENTS**

POST OFFICE BOX 655303 • DALLAS, TEXAS 75265

Copyright © 1997, Texas Instruments Incorporated

2-233

SN54ABTH25245, SN74ABTH25245

25-Ω OCTAL BUS TRANSCEIVERS

WITH 3-STATE OUTPUTS

SCBS251F - JUNE 1992 - REVISED MAY 1997

description (continued)

When V_{CC} is between 0 and 2.1 V, the device is in the high-impedance state during power up or power down. However, to ensure the high-impedance state above 2.1 V, \overline{OE} should be tied to V_{CC} through a pullup resistor; the minimum value of the resistor is determined by the current-sinking capability of the driver.

The SN54ABTH25245 is characterized for operation over the full military temperature range of -55°C to 125°C . The SN74ABTH25245 is characterized for operation from -40°C to 85°C .

FUNCTION TABLE

INPUTS		OPERATION
\overline{OE}	DIR	
L	L	B data to A bus
L	H	A data to B bus
H	X	Isolation

logic symbol†

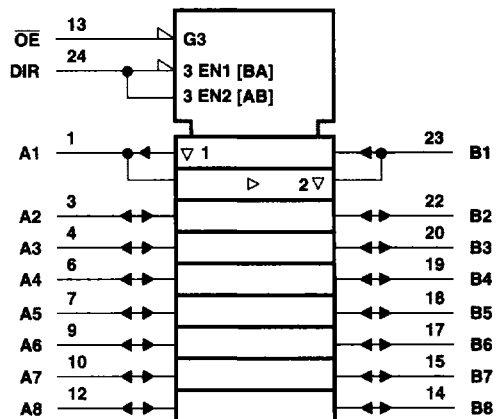

† This symbol is in accordance with ANSI/IEEE Std 91-1984 and IEC Publication 617-12. Pin numbers shown are for the DW, JT, and NT packages.

SN54ABTH25245, SN74ABTH25245
25-Ω OCTAL BUS TRANSCEIVERS
WITH 3-STATE OUTPUTS

SCBS251F - JUNE 1992 - REVISED MAY 1997

logic diagram (positive logic)

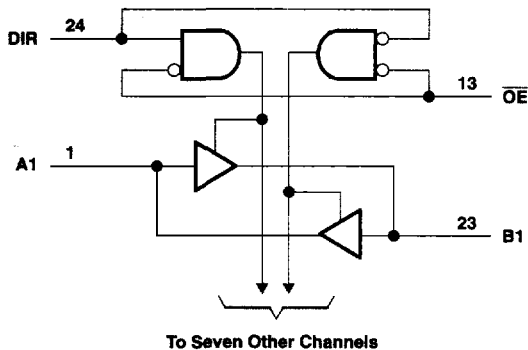

Pin numbers shown are for the DW, JT, and NT packages.

absolute maximum ratings over operating free-air temperature range (unless otherwise noted)†

Supply voltage range, V_{CC}	-0.5 V to 7 V
Input voltage range, V_I (except I/O ports) (see Note 1)	-0.5 V to 7 V
Voltage range applied to any output in the disabled or power-off state, V_O	-0.5 V to 5.5 V
Voltage range applied to any output in the high state, V_O	-0.5 V to V_{CC}
Input clamp current, I_{IK} ($V_I < 0$)	-18 mA
Output clamp current, I_{OK} ($V_O < 0$)	-50 mA
Current into any output in the low state, I_O : SN74ABTH25245 (A port)	376 mA
SN74ABTH25245 (B port)	128 mA
Package thermal impedance, θ_{JA} (see Note 2): DW package	81°C/W
NT package	67°C/W
Storage temperature range, T_{stg}	-65°C to 150°C

† Stresses beyond those listed under "absolute maximum ratings" may cause permanent damage to the device. These are stress ratings only, and functional operation of the device at these or any other conditions beyond those indicated under "recommended operating conditions" is not implied. Exposure to absolute-maximum-rated conditions for extended periods may affect device reliability.

- NOTES: 1. The input and output negative-voltage ratings may be exceeded if the input and output clamp-current ratings are observed.
 2. The package thermal impedance is calculated in accordance with EIA/JEDEC Std JESD51, except for through-hole packages, which use a trace length of zero.

SN54ABTH25245, SN74ABTH25245
25-Ω OCTAL BUS TRANSCEIVERS
WITH 3-STATE OUTPUTS

SCBS251F - JUNE 1992 - REVISED MAY 1997

recommended operating conditions (see Note 3)

			SN54ABTH25245		SN74ABTH25245		UNIT
			MIN	MAX	MIN	MAX	
V _{CC}	Supply voltage		4.5	5.5	4.5	5.5	V
V _{IH}	High-level input voltage		2		2		V
V _{IL}	Low-level input voltage		0.8		0.8		V
V _I	Input voltage		0	V _{CC}	0	V _{CC}	V
I _{IJK}	Input clamp current		-18		-18		mA
I _{OH}	High-level output current	A port	-80		-80		mA
		B port	-32		-32		
I _{OL}	Low-level output current	A port	188		188		mA
		B port	64		64		
Δt/Δv	Input transition rise or fall rate	Outputs enabled	Control inputs		4		ns/V
			A or B ports		10		
Δt/ΔV _{CC}	Power-up ramp rate		200		200		μs/V
T _A	Operating free-air temperature		-55	125	-40	85	°C

NOTE 3: Unused control pins must be held high or low to prevent them from floating.

SN54ABTH25245, SN74ABTH25245 25-Ω OCTAL BUS TRANSCEIVERS WITH 3-STATE OUTPUTS

SCBS251F - JUNE 1992 - REVISED MAY 1997

electrical characteristics over recommended operating free-air temperature range (unless otherwise noted)

PARAMETER	TEST CONDITIONS	SN54ABTH25245			SN74ABTH25245			UNIT
		MIN	TYP†	MAX	MIN	TYP†	MAX	
V_{IK}	$V_{CC} = 4.5\text{ V}$, $I_I = -18\text{ mA}$			-1.2			-1.2	V
V_{OH}	A port	$V_{CC} = 4.75\text{ V}$, $I_{OH} = -3\text{ mA}$		2.7			2.7	V
		$V_{CC} = 4.5\text{ V}$, $I_{OH} = -80\text{ mA}$		2.4			2.4	
	B port	$V_{CC} = 4.5\text{ V}$, $I_{OH} = -3\text{ mA}$		2.5			2.5	
		$V_{CC} = 5\text{ V}$, $I_{OH} = -3\text{ mA}$		3			3	
		$V_{CC} = 4.5\text{ V}$, $I_{OH} = -32\text{ mA}$		2*			2	
V_{OL}	A port	$V_{CC} = 4.5\text{ V}$	$I_{OL} = 94\text{ mA}$			0.55	0.55	V
			$I_{OL} = 188\text{ mA}$			0.7	0.7	
	B port	$V_{CC} = 4.5\text{ V}$	$I_{OL} = 64\text{ mA}$			0.55*	0.55	
V_{hys}				100		100		mV
I_I	Control inputs	$V_{CC} = 0\text{ to }5.5\text{ V}$, $V_I = V_{CC}\text{ or GND}$				± 1	± 1	μA
	A or B ports	$V_{CC} = 2.1\text{ V to }5.5\text{ V}$, $V_I = V_{CC}\text{ or GND}$				± 20	± 20	
$I_I(\text{hold})$	A or B ports	$V_{CC} = 4.5\text{ V}$	$V_I = 0.8\text{ V}$	100		100		μA
			$V_I = 2\text{ V}$	-100		-100		
I_{OZPU}^\ddagger		$V_{CC} = 0\text{ to }2.1\text{ V}$, $V_O = 0.5\text{ V to }2.7\text{ V}$, $\overline{OE} = X$				± 50	± 50	μA
I_{OZPD}^\ddagger		$V_{CC} = 2.1\text{ V to }0$, $V_O = 0.5\text{ V to }2.7\text{ V}$, $\overline{OE} = X$				± 50	± 50	μA
I_{off}		$V_{CC} = 0$, $V_I\text{ or }V_O \leq 4.5\text{ V}$				± 100	± 100	μA
I_{CEX}		$V_{CC} = 5.5\text{ V}$, $V_O = 5.5\text{ V}$				50	50	μA
I_O^\S	B port	$V_{CC} = 5.5\text{ V}$, $V_O = 2.5\text{ V}$				-50	-210	mA
I_{CC}		$V_{CC} = 5.5\text{ V}$, Outputs high, $V_I = V_{CC}\text{ or GND}$				500	500	μA
		Outputs open				20	20	mA
		Outputs disabled				500	500	μA
ΔI_{CC}^\parallel		$V_{CC} = 5.5\text{ V}$, One input at 3.4 V, Other inputs at $V_{CC}\text{ or GND}$				1	1	mA
C_i	Control inputs	$V_{CC} = 5\text{ V}$, $V_I = V_{CC}\text{ or GND}$				4	4	pF
C_{io}	A or B ports	$V_{CC} = 5\text{ V}$, $V_O = V_{CC}\text{ or GND}$				11.5	11.5	pF

* On products compliant to MIL-PRF-38535, this parameter does not apply.

† All typical values are at $V_{CC} = 5\text{ V}$, $T_A = 25^\circ\text{C}$.

‡ This parameter is characterized, but not production tested.

§ Not more than one output should be tested at a time, and the duration of the test should not exceed one second.

¶ This is the increase in supply current for each input that is at the specified TTL voltage level rather than V_{CC} or GND.

SN54ABTH25245, SN74ABTH25245
25-Ω OCTAL BUS TRANSCEIVERS
WITH 3-STATE OUTPUTS

SCBS251F - JUNE 1992 - REVISED MAY 1997

switching characteristics over recommended ranges of supply voltage and operating free-air temperature, $C_L = 50$ pF (unless otherwise noted) (see Figure 1)

PARAMETER	FROM (INPUT)	TO (OUTPUT)	VCC = 5 V, TA = 25°C			SN54ABTH25245		SN74ABTH25245		UNIT
			MIN	TYP	MAX	MIN	MAX	MIN	MAX	
tPLH	A or B	B or A	1	2.3	3.5	1		1	3.9	ns
tPHL			1	2.4	3.5	1		1	4.3	
tPZH	\overline{OE}	A or B	1.5	3.7	5.4	1.5		1.5	6.5	ns
tPZL			1.4	4	5.8	1.4		1.4	6.8	
tPHZ	\overline{OE}	A or B	2	4.3	6.1	2		2	7.2	ns
tPLZ			2	3.9	5.8	2		2	6.4	

SN54ABTH25245, SN74ABTH25245
25-Ω OCTAL BUS TRANSCEIVERS
WITH 3-STATE OUTPUTS

SCBS251F – JUNE 1992 – REVISED MAY 1997

PARAMETER MEASUREMENT INFORMATION

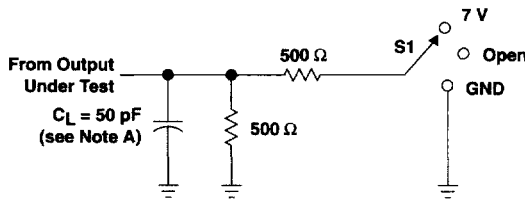

TEST	S1
t_{PLH}/t_{PHL}	Open
t_{PLZ}/t_{PZL}	7 V
t_{PHZ}/t_{PZH}	Open

LOAD CIRCUIT

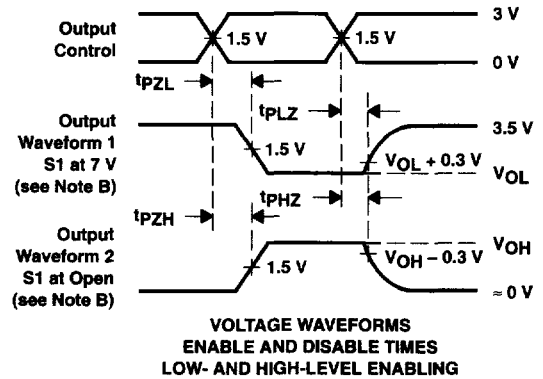
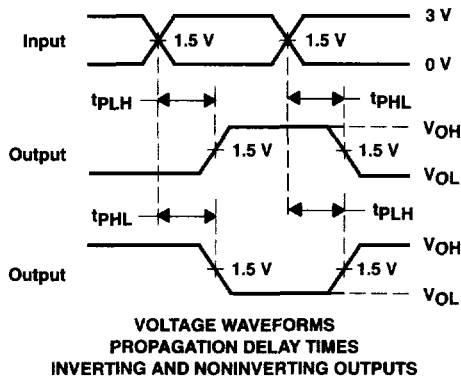
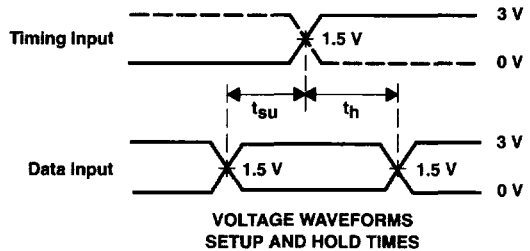
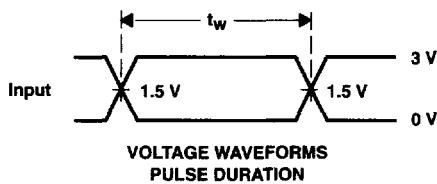

- NOTES: A. C_L includes probe and jig capacitance.
 B. Waveform 1 is for an output with internal conditions such that the output is low except when disabled by the output control. Waveform 2 is for an output with internal conditions such that the output is high except when disabled by the output control.
 C. All input pulses are supplied by generators having the following characteristics: $PRR \leq 10$ MHz, $Z_O = 50 \Omega$, $t_r \leq 2.5$ ns, $t_f \leq 2.5$ ns.
 D. The outputs are measured one at a time with one transition per measurement.

Figure 1. Load Circuit and Voltage Waveforms