

# SN54ABTH162460, SN74ABTH162460 4-TO-1 MULTIPLEXED/DEMULPLEXED REGISTERED TRANSCEIVERS WITH 3-STATE OUTPUTS

SCBS241E – FEBRUARY 1993 – REVISED MAY 1997

- **Members of the Texas Instruments Widebus™ Family**
- **B-Port Outputs Have Equivalent 25-Ω Series Resistors, So No External Resistors Are Required**
- **State-of-the-Art EPIC-IIB™ BiCMOS Design Significantly Reduces Power Dissipation**
- **Latch-Up Performance Exceeds 500 mA Per JEDEC Standard JESD-17**
- **Typical  $V_{OLP}$  (Output Ground Bounce) < 1 V at  $V_{CC} = 5 V$ ,  $T_A = 25^\circ C$**
- **High-Impedance State During Power Up and Power Down**
- **Distributed  $V_{CC}$  and GND Pin Configuration Minimizes High-Speed Switching Noise**
- **Flow-Through Architecture Optimizes PCB Layout**
- **Bus Hold on Data Inputs Eliminates the Need for External Pullup/Pulldown Resistors**
- **Package Options Include Plastic 300-mil Shrink Small-Outline (DL) Package and 380-mil Fine-Pitch Ceramic Flat (WD) Package Using 25-mil Center-to-Center Spacings**

SN54ABTH162460 . . . WD PACKAGE  
SN74ABTH162460 . . . DL PACKAGE  
(TOP VIEW)

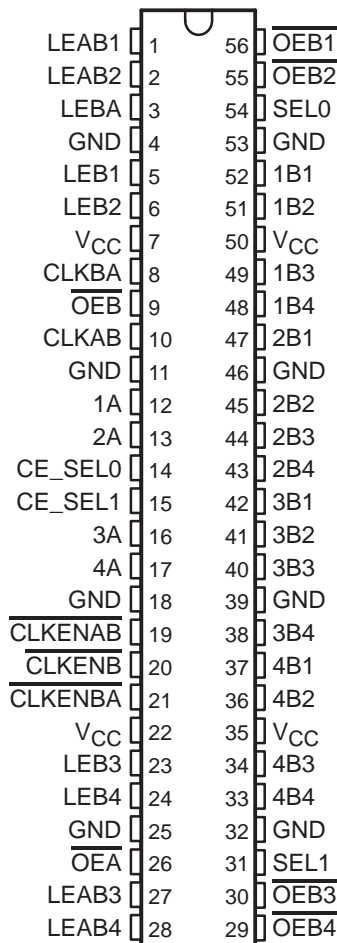

## description

The 'ABTH162460 are 4-bit to 1-bit multiplexed registered transceivers used in applications where four separate data paths must be multiplexed onto or demultiplexed from a single data path. Typical applications include multiplexing and/or demultiplexing of address and data information in microprocessor or bus-interface applications. This device also is useful in memory-interleaving applications.

Five 4-bit I/O ports (1A–4A, 1B1–4, 2B1–4, 3B1–4, and 4B1–4) are available for address and/or data transfer. The output-enable ( $\overline{OEB}$ ,  $\overline{OEB1}$ – $\overline{OEB4}$ , and  $\overline{OEA}$ ) inputs control the bus-transceiver functions. These control signals also allow 4-bit or 16-bit control, depending on the  $\overline{OEB}$  level.



Please be aware that an important notice concerning availability, standard warranty, and use in critical applications of Texas Instruments semiconductor products and disclaimers thereto appears at the end of this data sheet.

Widebus and EPIC-IIB are trademarks of Texas Instruments Incorporated.

UNLESS OTHERWISE NOTED this document contains PRODUCTION DATA information current as of publication date. Products conform to specifications per the terms of Texas Instruments standard warranty. Production processing does not necessarily include testing of all parameters.

 **TEXAS  
INSTRUMENTS**

POST OFFICE BOX 655303 • DALLAS, TEXAS 75265

Copyright © 1997, Texas Instruments Incorporated

# SN54ABTH162460, SN74ABTH162460 4-TO-1 MULTIPLEXED/DEMULTIPLEXED REGISTERED TRANSCEIVERS WITH 3-STATE OUTPUTS

SCBS241E – FEBRUARY 1993 – REVISED MAY 1997

## description (continued)

Address and/or data information can be stored using the internal storage latches/flip-flops. The latch-enable (LEB1–LEB4, LEBA, and LEAB1–LEAB4) and clock/clock-enable (CLK/ $\overline{\text{CLKEN}}$ ) inputs are used to control data storage. When either one of the latch-enable inputs is high, the latch is transparent (clock is a don't care as long as the latch enable is high). When the latch-enable input goes low (providing that the clock does not transit from low to high), the data present at the inputs is latched and remains latched until the latch-enable input is returned high. When the clock enable is low and the corresponding latch enable is low, data can be clocked on the low-to-high transition of the clock. When either the clock enable or the corresponding latch enable is high, the clock is a don't care.

Four select (SEL0, SEL1, CE\_SEL0, and CE\_SEL1) pins are provided to multiplex data (A port), or to select one of four clock enables (B port). This allows the user the flexibility of controlling one bit at a time.

The B-port outputs, which are designed to sink up to 12 mA, include equivalent 25- $\Omega$  series resistors to reduce overshoot and undershoot.

Active bus-hold circuitry is provided to hold unused or floating data inputs at a valid logic level.

When  $V_{CC}$  is between 0 and 2.1 V, the device is in the high-impedance state during power up or power down. However, to ensure the high-impedance state above 2.1 V,  $\overline{\text{OE}}$  should be tied to  $V_{CC}$  through a pullup resistor; the minimum value of the resistor is determined by the current-sinking capability of the driver.

The SN54ABTH162460 is characterized for operation over the full military temperature range of  $-55^{\circ}\text{C}$  to  $125^{\circ}\text{C}$ . The SN74ABTH162460 is characterized for operation from  $-40^{\circ}\text{C}$  to  $85^{\circ}\text{C}$ .

### Function Tables

A-TO-B OUTPUT ENABLE†

INPUTS		OUTPUT
$\overline{\text{OEB}}$	$\overline{\text{OEBn}}$	$\text{Bn}$
H	H	Z
H	L	Z
L	H	Z
L	L	Active

† n = 1, 2, 3, 4

A-TO-B STORAGE  
(assuming  $\overline{\text{OEB}} = \text{L}$ ,  $\overline{\text{OEBn}} = \text{L}$ )‡

INPUTS								OUTPUTS			
$\overline{\text{CLKENAB}}$	CE_SEL1	CE_SEL0	CLKAB	LEAB1	LEAB2	LEAB3	LEAB4	B1	B2	B3	B4
X	X	X	H or L	H	L	L	L	A	A <sub>0</sub>	A <sub>0</sub>	A <sub>0</sub>
X	X	X	H or L	H	H	H	L	A	A	A	A <sub>0</sub>
L	X	X	L	L	L	L	L	A <sub>0</sub>	A <sub>0</sub>	A <sub>0</sub>	A <sub>0</sub>
L	L	L	↑	L	L	L	L	A	A <sub>0</sub>	A <sub>0</sub>	A <sub>0</sub>
L	L	H	↑	L	L	L	L	A <sub>0</sub>	A	A <sub>0</sub>	A <sub>0</sub>
L	H	L	↑	L	L	L	L	A <sub>0</sub>	A <sub>0</sub>	A	A <sub>0</sub>
L	H	H	↑	L	L	L	L	A <sub>0</sub>	A <sub>0</sub>	A <sub>0</sub>	A
H	X	X	↑	L	L	L	L	A <sub>0</sub>	A <sub>0</sub>	A <sub>0</sub>	A <sub>0</sub>

‡ This table does not cover all the latch-enable cases since they have similar results.



SN54ABTH162460, SN74ABTH162460  
**4-TO-1 MULTIPLEXED/DEMULTIPLEXED REGISTERED TRANSCEIVERS  
 WITH 3-STATE OUTPUTS**

SCBS241E – FEBRUARY 1993 – REVISED MAY 1997

**Function Tables (Continued)**

**B-TO-A STORAGE  
 (before point P)**

INPUTS								P						
CLKENB	CLKBA	LEB1	LEB2	LEB3	LEB4	SEL1	SEL0							
X	X	H	L	L	L	L	L	B1						
X	X	L	H	L	L	L	H	B2						
X	X	L	L	H	L	H	L	B3						
X	X	L	L	L	H	H	H	B4						
L							↑	L	L	B1				
								L	L	L	L	L	H	B2
								H	L	L	L	L	L	B3
								H	H	L	L	L	L	B4
L								L	L	B1 <sup>†</sup>				
								L	L	L	L	L	H	B2 <sup>†</sup>
								H	L	L	L	L	L	B3 <sup>†</sup>
								H	H	L	L	L	L	B4 <sup>†</sup>

† Output level before the indicated steady-state input conditions were established

**B-TO-A STORAGE  
 (after point P)**

INPUTS					OUTPUT
CLKENB <sup>A</sup>	CLKBA	LEBA	$\overline{OE}A$	B	A
X	X	X	H	X	Z
X	X	H	L	L	L
X	X	H	L	H	H
H	X	L	L	X	A <sub>0</sub> <sup>†</sup>
L	↑	L	L	L	L
L	↑	L	L	H	H
L	L	L	L	X	A <sub>0</sub> <sup>†</sup>

† Output level before the indicated steady-state input conditions were established

# SN54ABTH162460, SN74ABTH162460

## 4-TO-1 MULTIPLEXED/DEMULTIPLEXED REGISTERED TRANSCEIVERS

### WITH 3-STATE OUTPUTS

SCBS241E – FEBRUARY 1993 – REVISED MAY 1997

#### logic diagram (positive logic)

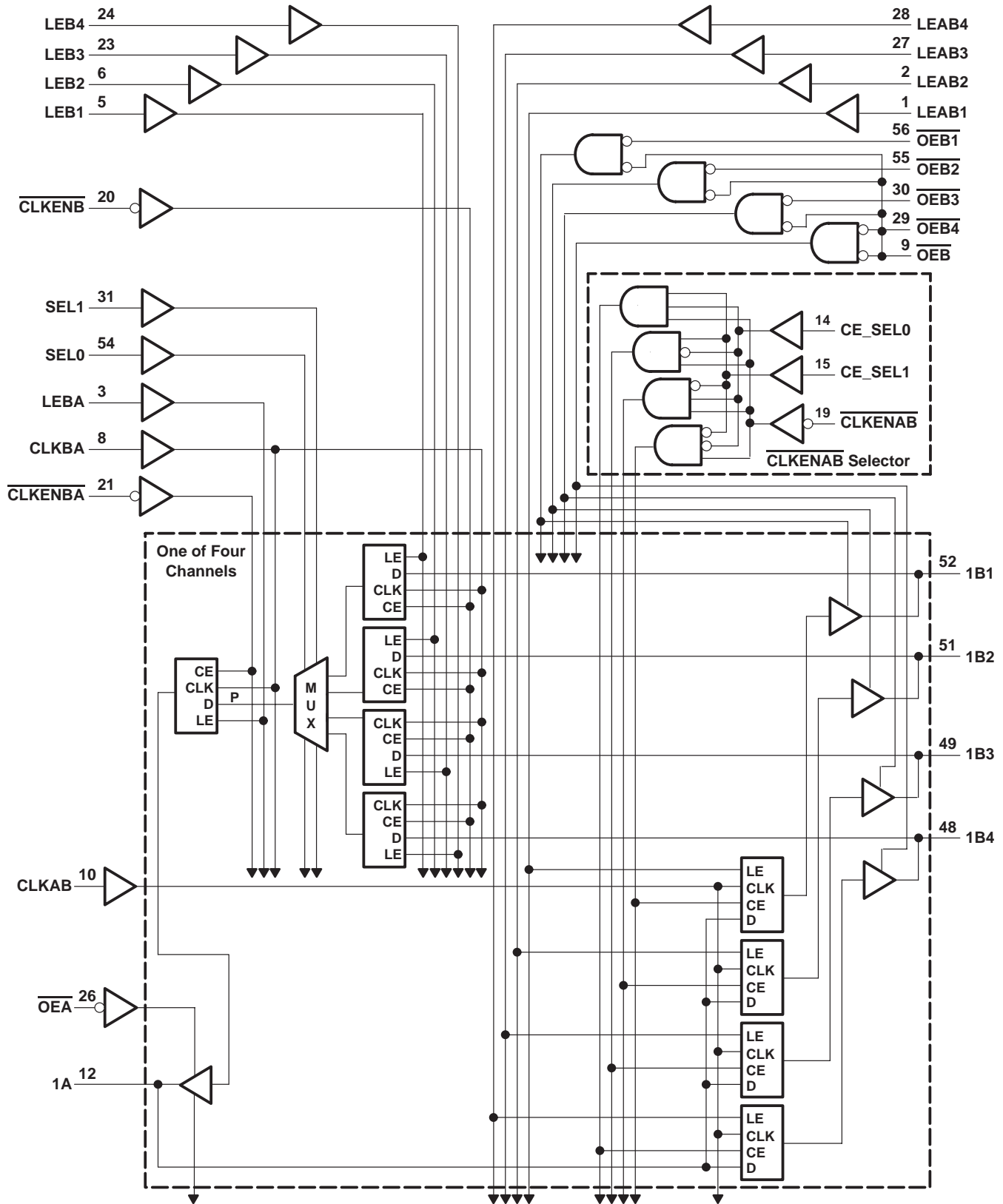

# SN54ABTH162460, SN74ABTH162460 4-TO-1 MULTIPLEXED/DEMULPLEXED REGISTERED TRANSCEIVERS WITH 3-STATE OUTPUTS

SCBS241E – FEBRUARY 1993 – REVISED MAY 1997

## absolute maximum ratings over operating free-air temperature range (unless otherwise noted)†

Supply voltage range, $V_{CC}$ .....	–0.5 V to 7 V
Input voltage range, $V_I$ (except I/O ports) (see Note 1) .....	–0.5 V to 7 V
Voltage range applied to any output in the high or power-off state, $V_O$ .....	–0.5 V to 5.5 V
Current into any output in the low state, $I_O$ : SN54ABTH162460 (A port) .....	96 mA
SN74ABTH162460 (A port) .....	128 mA
B port .....	30 mA
Input clamp current, $I_{IK}$ ( $V_I < 0$ ) .....	–18 mA
Output clamp current, $I_{OK}$ ( $V_O < 0$ ) .....	–50 mA
Package thermal impedance, $\theta_{JA}$ (see Note 2): DL package .....	74 °C/W
Storage temperature range, $T_{stg}$ .....	–65°C to 150°C

† Stresses beyond those listed under “absolute maximum ratings” may cause permanent damage to the device. These are stress ratings only, and functional operation of the device at these or any other conditions beyond those indicated under “recommended operating conditions” is not implied. Exposure to absolute-maximum-rated conditions for extended periods may affect device reliability.

- NOTES: 1. The input and output negative-voltage ratings may be exceeded if the input and output clamp-current ratings are observed.  
2. The package thermal impedance is calculated in accordance with EIA/JEDEC Std JESD51.

## recommended operating conditions (see Note 3)

		SN54ABTH162460			SN74ABTH162460			UNIT	
		MIN	NOM	MAX	MIN	NOM	MAX		
$V_{CC}$	Supply voltage	4.5	5	5.5	4.5	5	5.5	V	
$V_{IH}$	High-level input voltage	2			2			V	
$V_{IL}$	Low-level input voltage			0.8			0.8	V	
$V_I$	Input voltage	0		$V_{CC}$	0		$V_{CC}$	V	
$I_{OH}$	High-level output current	A port		–24	–32		mA		
		B port		–12	–12				
$I_{OL}$	Low-level output current	A port		48	64		mA		
		B port		12	12				
$\Delta t/\Delta v$	Input transition rise or fall rate	Outputs enabled			10	10		ns/V	
$\Delta t/\Delta V_{CC}$	Power-up ramp rate	200				200			µs/V
$T_A$	Operating free-air temperature	–55	125		–40	85		°C	

NOTE 3: Unused control pins must be held high or low to prevent them from floating.

**SN54ABTH162460, SN74ABTH162460**  
**4-TO-1 MULTIPLEXED/DEMULTIPLEXED REGISTERED TRANSCEIVERS**  
**WITH 3-STATE OUTPUTS**

SCBS241E – FEBRUARY 1993 – REVISED MAY 1997

**electrical characteristics over recommended operating free-air temperature range (unless otherwise noted)**

PARAMETER		TEST CONDITIONS		SN54ABTH162460			SN74ABTH162460			UNIT
				MIN	TYP†	MAX	MIN	TYP†	MAX	
V <sub>IK</sub>		V <sub>CC</sub> = 4.5 V, I <sub>I</sub> = -18 mA		-1.2			-1.2			V
V <sub>OH</sub>	A port	V <sub>CC</sub> = 5 V, I <sub>OH</sub> = -3 mA		3	3.4		3	3.4	V	
		V <sub>CC</sub> = 4.5 V, I <sub>OH</sub> = -3 mA		2.5	3					
	V <sub>CC</sub> = 4.5 V, I <sub>OH</sub> = -32 mA					2	2.7			
	B port	V <sub>CC</sub> = 5 V, I <sub>OH</sub> = -1 mA		3.8	4.2		3.85			
		V <sub>CC</sub> = 5 V, I <sub>OH</sub> = -1 mA		3.3	3.7		3.35			
		V <sub>CC</sub> = 4.5 V, I <sub>OH</sub> = -3 mA		3	3.6		3.1			
V <sub>CC</sub> = 4.5 V, I <sub>OH</sub> = -12 mA					2.6					
V <sub>OL</sub>	A port	V <sub>CC</sub> = 4.5 V, I <sub>OL</sub> = 24 mA		0.25	0.55			V		
		V <sub>CC</sub> = 4.5 V, I <sub>OL</sub> = 64 mA					0.3		0.55	
	B port	V <sub>CC</sub> = 4.5 V, I <sub>OL</sub> = 8 mA		0.4	0.8		0.4		0.65	
		V <sub>CC</sub> = 4.5 V, I <sub>OL</sub> = 12 mA					0.5		0.8	
V <sub>hys</sub>				100			100			mV
I <sub>I</sub>	Control inputs	V <sub>CC</sub> = 0 to 5.5 V, V <sub>I</sub> = V <sub>CC</sub> or GND		±1			±1			μA
	A or B ports	V <sub>CC</sub> = 2.1 V to 5.5 V, V <sub>I</sub> = V <sub>CC</sub> or GND		±20			±20			
I <sub>I</sub> (hold)	A or B ports	V <sub>CC</sub> = 5.5 V, V <sub>I</sub> = 0.8 V		75	500		75	500	μA	
		V <sub>CC</sub> = 4.5 V, V <sub>I</sub> = 2 V		-75	-500		-75	-500		
I <sub>O</sub> ‡	A port	V <sub>CC</sub> = 5.5 V, V <sub>O</sub> = 2.5 V		-50	-110	-180	-50	-180	mA	
	B port	V <sub>CC</sub> = 5.5 V, V <sub>O</sub> = 2.5 V		-25	-55	-90	-25	-90		
		V <sub>CC</sub> = 5.5 V, V <sub>O</sub> = 0		-50	-110	-180	-50	-180		
I <sub>CEX</sub>	Outputs high	V <sub>CC</sub> = 5.5 V, V <sub>O</sub> = 5.5 V		50			50			μA
I <sub>off</sub>		V <sub>CC</sub> = 0, V <sub>I</sub> or V <sub>O</sub> ≤ 4.5 V		±100			±100			μA
I <sub>OZPU</sub> §		V <sub>CC</sub> = 0 to 2.1 V, V <sub>O</sub> = 0.5 V to 2.7 V, $\overline{OE} = X$		±50			±50			μA
I <sub>OZPD</sub> §		V <sub>CC</sub> = 2.1 V to 0, V <sub>O</sub> = 0.5 V to 2.7 V, $\overline{OE} = X$		±50			±50			μA
I <sub>CC</sub>	Outputs high	V <sub>CC</sub> = 5.5 V, Outputs open		1.5			0.7	1.5	mA	
	A port low			10			6	10		
	B port low			32			18	32		
	Outputs disabled			1.5			0.7	1.5		
ΔI <sub>CC</sub> ¶		V <sub>CC</sub> = 5.5 V, One input at 3.4 V, Other inputs at V <sub>CC</sub> or GND		1			1			mA
C <sub>i</sub>	Control inputs	V <sub>I</sub> = 2.5 V or 0.5 V		3.5			3.5			pF
C <sub>io</sub>	A or B ports	V <sub>O</sub> = 2.5 V or 0.5 V		8			8			pF

† All typical values are at V<sub>CC</sub> = 5 V, T<sub>A</sub> = 25°C.

‡ Not more than one output should be tested at a time, and the duration of the test should not exceed one second.

§ This parameter is characterized but not production tested.

¶ This is the increase in supply current for each input that is at the specified TTL voltage level rather than V<sub>CC</sub> or GND.

**SN54ABTH162460, SN74ABTH162460**  
**4-TO-1 MULTIPLEXED/DEMULTIPLEXED REGISTERED TRANSCEIVERS**  
**WITH 3-STATE OUTPUTS**

SCBS241E – FEBRUARY 1993 – REVISED MAY 1997

**timing requirements over recommended ranges of supply voltage and operating free-air temperature (unless otherwise noted)(see Figure 1)**

		$V_{CC} = 5\text{ V},$ $T_A = 25^\circ\text{C}$		SN54ABTH162460		SN74ABTH162460		UNIT
		MIN	MAX	MIN	MAX	MIN	MAX	
$f_{\text{clock}}$	Clock frequency	0	160	0	160	0	160	MHz
$t_w$	Pulse duration	CLKAB high or low	3.8	3.8	3.8	3.8	ns	
		CLKBA high or low	4.5	4.5	4.5			
		LEAB1, 2, 3, or 4 high	2.8	2.8	2.8			
		LEBA high	2.8	2.8	2.8			
		LEB1, 2, 3, or 4 high	3	3	3			
$t_{su}$	Before CLKAB $\uparrow$	A bus	2.5	2.5	2.5	ns		
		CE_SEL0/1	3.2	3.2	3.2			
		CLKENAB	3.2	3.2	3.2			
	Before LEAB1, 2, 3, or 4 $\downarrow$	A bus	3.6	3.6	3.6			
		Before CLKBA $\uparrow$	B bus	3.8	3.8		3.8	
			CLKENB	2.3	2.3		2.3	
	CLKENBA		2.5	2.5	2.5			
	LEB1, 2, 3, or 4		4.3	4.3	4.3			
	Before LEB1, 2, 3, or 4 $\downarrow$	SEL0/1	4.5	4.5	4.5			
		Before LEBA $\downarrow$	B bus	3.2	3.2		3.2	
			B bus	4	4		4	
	LEB1, 2, 3, or 4		4.4	4.4	4.4			
	$t_h$	After CLKAB $\uparrow$	SEL0/1	4.3	4.3		4.3	
			After LEAB1, 2, 3, or 4 $\downarrow$	B bus	3.2		3.2	3.2
				A bus	1.2		1.2	1.2
After CLKBA $\uparrow$		B bus		1.3	1.3	1.3		
		CLKENB	1	1	1			
		CLKENBA	1	1	1			
After LEB1, 2, 3, or 4 $\downarrow$		SEL0/1	0	0	0			
		After LEBA $\downarrow$	B bus	1.5	1.5	1.5		
			B bus	0.4	0.4	0.4		
SEL0/1	0.1		0.1	0.1				

PRODUCT PREVIEW information concerns products in the formative or design phase of development. Characteristic data and other specifications are design goals. Texas Instruments reserves the right to change or discontinue these products without notice.



POST OFFICE BOX 655303 • DALLAS, TEXAS 75265

**SN54ABTH162460, SN74ABTH162460**  
**4-TO-1 MULTIPLEXED/DEMULTIPLEXED REGISTERED TRANSCEIVERS**  
**WITH 3-STATE OUTPUTS**

SCBS241E – FEBRUARY 1993 – REVISED MAY 1997

switching characteristics over recommended ranges of supply voltage and operating free-air temperature,  $C_L = 50$  pF (unless otherwise noted) (see Figure 1)

PARAMETER	FROM (INPUT)	TO (OUTPUT)	$V_{CC} = 5$ V, $T_A = 25^\circ$ C			SN54ABTH162460		SN74ABTH162460		UNIT
			MIN	TYP	MAX	MIN	MAX	MIN	MAX	
$f_{max}$			160			160		160		MHz
$t_{PLH}$	B	A	2	3.6	5.9	2	7.1	2	6.5	ns
$t_{PHL}$			2	3.5	5.8	2	6.8	2	6.5	
$t_{PZH}$	$\overline{OEA}$	A	1.5	2.8	4.8	1.5	5.9	1.5	5.6	ns
$t_{PZL}$			1.5	2.6	4.8	1.5	5.7	1.5	5.5	
$t_{PHZ}$	$\overline{OEA}$	A	2	3.8	5.3	2	6	2	5.9	ns
$t_{PLZ}$			1.5	4	6.1	1.5	7	1.5	6.5	
$t_{PLH}$	A	B	2	3.3	5.5	2	6.5	2	6.2	ns
$t_{PHL}$			2	3.7	5.8	2	6.8	2	6.5	
$t_{PZH}$	$\overline{OEB}$	B	2	3.9	5.8	2	7.1	2	6.8	ns
$t_{PZL}$			2	3.7	5.6	2	6.6	1.5	6.3	
$t_{PHZ}$	$\overline{OEB}$	B	2	4	5.6	2	6.4	2	6.2	ns
$t_{PLZ}$			2	3.7	5.2	2	6.1	2	5.8	
$t_{PZH}$	$\overline{OEB1}, \bar{2}, \bar{3}, \bar{4}$	B	2	3.7	5.8	2	6.8	2	6.6	ns
$t_{PZL}$			2	3.5	5.4	2	6.4	2	6.2	
$t_{PHZ}$	$\overline{OEB1}, \bar{2}, \bar{3}, \bar{4}$	B	1.5	3.3	4.8	1.5	5.4	1.5	5.3	ns
$t_{PLZ}$			1.5	3.1	4.4	1.5	5.1	1.5	4.9	
$t_{PLH}$	CLKBA	A	1.5	4.2	6.7	1.5	8.1	1.5	7.4	ns
$t_{PHL}$			1.5	4.4	6.9	1.5	8.4	1.5	7.7	
$t_{PLH}$	CLKAB	B	2	3.5	5.8	2	6.9	2	6.5	ns
$t_{PHL}$			2	3.7	6	2	7	2	6.5	
$t_{PLH}$	LEBA	A	1.5	3	5.2	1.5	6.3	1.5	5.8	ns
$t_{PHL}$			1.5	3	5	1.5	6.3	1.5	5.8	
$t_{PLH}$	LEAB1, 2, 3, 4	B	2	3.4	5.4	2	6.5	2	6.2	ns
$t_{PHL}$			2	3.6	5.7	2	6.3	2	6.2	
$t_{PLH}$	LEBA1, 2, 3, 4	A	2	4	6.5	2	7.8	2	7.2	ns
$t_{PHL}$			2	4	6.1	2	7.5	2	6.8	
$t_{PLH}$	SEL	A	2	4.1	6.7	2	8.1	2	7.5	ns
$t_{PHL}$			2	3.8	6.2	2	7.3	2	6.9	

PRODUCT PREVIEW information concerns products in the formative or design phase of development. Characteristic data and other specifications are design goals. Texas Instruments reserves the right to change or discontinue these products without notice.



POST OFFICE BOX 655303 • DALLAS, TEXAS 75265

**SN54ABTH162460, SN74ABTH162460**  
**4-TO-1 MULTIPLEXED/DEMULTIPLEXED REGISTERED TRANSCEIVERS**  
**WITH 3-STATE OUTPUTS**

SCBS241E – FEBRUARY 1993 – REVISED MAY 1997

**PARAMETER MEASUREMENT INFORMATION**

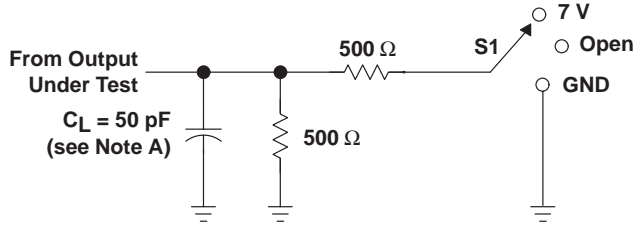

**LOAD CIRCUIT**

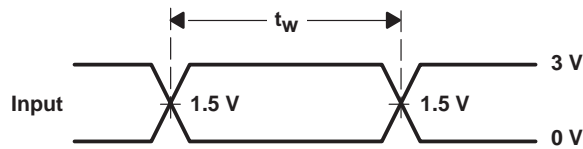

**VOLTAGE WAVEFORMS  
PULSE DURATION**

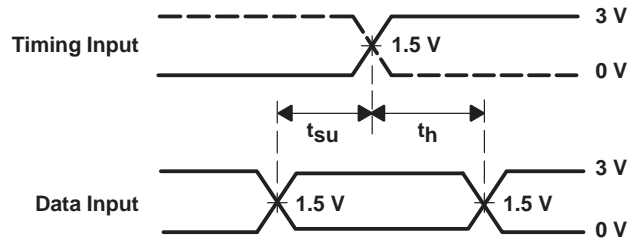

**VOLTAGE WAVEFORMS  
SETUP AND HOLD TIMES**

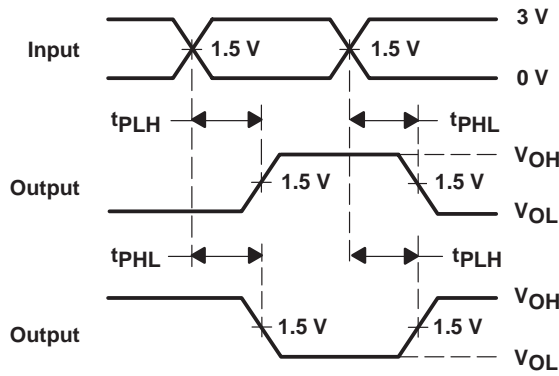

**VOLTAGE WAVEFORMS  
PROPAGATION DELAY TIMES  
INVERTING AND NONINVERTING OUTPUTS**

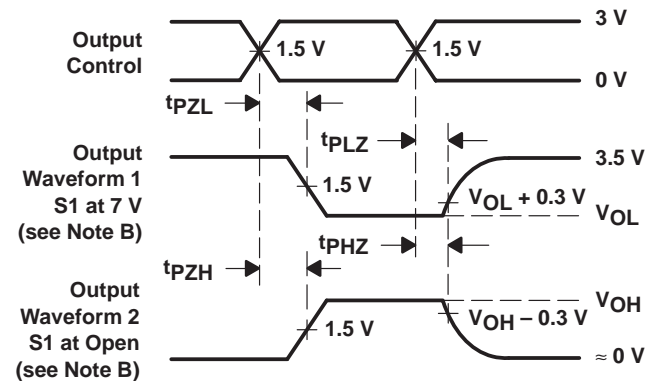

**VOLTAGE WAVEFORMS  
ENABLE AND DISABLE TIMES  
LOW- AND HIGH-LEVEL ENABLING**

- NOTES: A.  $C_L$  includes probe and jig capacitance.  
 B. Waveform 1 is for an output with internal conditions such that the output is low except when disabled by the output control. Waveform 2 is for an output with internal conditions such that the output is high except when disabled by the output control.  
 C. All input pulses are supplied by generators having the following characteristics:  $PRR \leq 10 \text{ MHz}$ ,  $Z_O = 50 \Omega$ ,  $t_r \leq 2.5 \text{ ns}$ ,  $t_f \leq 2.5 \text{ ns}$ .  
 D. The outputs are measured one at a time with one transition per measurement.

**Figure 1. Load Circuit and Voltage Waveforms**

**PACKAGING INFORMATION**

Orderable Device	Status <sup>(1)</sup>	Package Type	Package Drawing	Pins	Package Qty	Eco Plan <sup>(2)</sup>	Lead/Ball Finish	MSL Peak Temp <sup>(3)</sup>
74ABTH162460DGGRE4	ACTIVE	TSSOP	DGG	56	2000	Green (RoHS & no Sb/Br)	CU NIPDAU	Level-1-260C-UNLIM
74ABTH162460DGGRG4	ACTIVE	TSSOP	DGG	56	2000	Green (RoHS & no Sb/Br)	CU NIPDAU	Level-1-260C-UNLIM
74ABTH162460DLG4	ACTIVE	SSOP	DL	56	20	Green (RoHS & no Sb/Br)	CU NIPDAU	Level-1-260C-UNLIM
74ABTH162460DLRG4	ACTIVE	SSOP	DL	56	1000	Green (RoHS & no Sb/Br)	CU NIPDAU	Level-1-260C-UNLIM
SN74ABTH162460DGGR	ACTIVE	TSSOP	DGG	56	2000	Green (RoHS & no Sb/Br)	CU NIPDAU	Level-1-260C-UNLIM
SN74ABTH162460DL	ACTIVE	SSOP	DL	56	20	Green (RoHS & no Sb/Br)	CU NIPDAU	Level-1-260C-UNLIM
SN74ABTH162460DLR	ACTIVE	SSOP	DL	56	1000	Green (RoHS & no Sb/Br)	CU NIPDAU	Level-1-260C-UNLIM

<sup>(1)</sup> The marketing status values are defined as follows:

**ACTIVE:** Product device recommended for new designs.

**LIFEBUY:** TI has announced that the device will be discontinued, and a lifetime-buy period is in effect.

**NRND:** Not recommended for new designs. Device is in production to support existing customers, but TI does not recommend using this part in a new design.

**PREVIEW:** Device has been announced but is not in production. Samples may or may not be available.

**OBSELETE:** TI has discontinued the production of the device.

<sup>(2)</sup> Eco Plan - The planned eco-friendly classification: Pb-Free (RoHS), Pb-Free (RoHS Exempt), or Green (RoHS & no Sb/Br) - please check <http://www.ti.com/productcontent> for the latest availability information and additional product content details.

**TBD:** The Pb-Free/Green conversion plan has not been defined.

**Pb-Free (RoHS):** TI's terms "Lead-Free" or "Pb-Free" mean semiconductor products that are compatible with the current RoHS requirements for all 6 substances, including the requirement that lead not exceed 0.1% by weight in homogeneous materials. Where designed to be soldered at high temperatures, TI Pb-Free products are suitable for use in specified lead-free processes.

**Pb-Free (RoHS Exempt):** This component has a RoHS exemption for either 1) lead-based flip-chip solder bumps used between the die and package, or 2) lead-based die adhesive used between the die and leadframe. The component is otherwise considered Pb-Free (RoHS compatible) as defined above.

**Green (RoHS & no Sb/Br):** TI defines "Green" to mean Pb-Free (RoHS compatible), and free of Bromine (Br) and Antimony (Sb) based flame retardants (Br or Sb do not exceed 0.1% by weight in homogeneous material)

<sup>(3)</sup> MSL, Peak Temp. -- The Moisture Sensitivity Level rating according to the JEDEC industry standard classifications, and peak solder temperature.

**Important Information and Disclaimer:**The information provided on this page represents TI's knowledge and belief as of the date that it is provided. TI bases its knowledge and belief on information provided by third parties, and makes no representation or warranty as to the accuracy of such information. Efforts are underway to better integrate information from third parties. TI has taken and continues to take reasonable steps to provide representative and accurate information but may not have conducted destructive testing or chemical analysis on incoming materials and chemicals. TI and TI suppliers consider certain information to be proprietary, and thus CAS numbers and other limited information may not be available for release.

In no event shall TI's liability arising out of such information exceed the total purchase price of the TI part(s) at issue in this document sold by TI to Customer on an annual basis.

**TAPE AND REEL INFORMATION**



**QUADRANT ASSIGNMENTS FOR PIN 1 ORIENTATION IN TAPE**



\*All dimensions are nominal

Device	Package Type	Package Drawing	Pins	SPQ	Reel Diameter (mm)	Reel Width W1 (mm)	A0 (mm)	B0 (mm)	K0 (mm)	P1 (mm)	W (mm)	Pin1 Quadrant
SN74ABTH162460DGGR	TSSOP	DGG	56	2000	330.0	24.4	8.6	15.6	1.8	12.0	24.0	Q1
SN74ABTH162460DLR	SSOP	DL	56	1000	330.0	32.4	11.35	18.67	3.1	16.0	32.0	Q1

**TAPE AND REEL BOX DIMENSIONS**



\*All dimensions are nominal

Device	Package Type	Package Drawing	Pins	SPQ	Length (mm)	Width (mm)	Height (mm)
SN74ABTH162460DGGR	TSSOP	DGG	56	2000	346.0	346.0	41.0
SN74ABTH162460DLR	SSOP	DL	56	1000	346.0	346.0	49.0

DGG (R-PDSO-G\*\*)

PLASTIC SMALL-OUTLINE PACKAGE

48 PINS SHOWN



- NOTES: A. All linear dimensions are in millimeters.  
 B. This drawing is subject to change without notice.  
 C. Body dimensions do not include mold protrusion not to exceed 0,15.  
 D. Falls within JEDEC MO-153

DL (R-PDSO-G\*\*)

PLASTIC SMALL-OUTLINE PACKAGE

48 PINS SHOWN



- NOTES: A. All linear dimensions are in inches (millimeters).  
 B. This drawing is subject to change without notice.  
 C. Body dimensions do not include mold flash or protrusion not to exceed 0.006 (0,15).  
 D. Falls within JEDEC MO-118

## IMPORTANT NOTICE

Texas Instruments Incorporated and its subsidiaries (TI) reserve the right to make corrections, modifications, enhancements, improvements, and other changes to its products and services at any time and to discontinue any product or service without notice. Customers should obtain the latest relevant information before placing orders and should verify that such information is current and complete. All products are sold subject to TI's terms and conditions of sale supplied at the time of order acknowledgment.

TI warrants performance of its hardware products to the specifications applicable at the time of sale in accordance with TI's standard warranty. Testing and other quality control techniques are used to the extent TI deems necessary to support this warranty. Except where mandated by government requirements, testing of all parameters of each product is not necessarily performed.

TI assumes no liability for applications assistance or customer product design. Customers are responsible for their products and applications using TI components. To minimize the risks associated with customer products and applications, customers should provide adequate design and operating safeguards.

TI does not warrant or represent that any license, either express or implied, is granted under any TI patent right, copyright, mask work right, or other TI intellectual property right relating to any combination, machine, or process in which TI products or services are used. Information published by TI regarding third-party products or services does not constitute a license from TI to use such products or services or a warranty or endorsement thereof. Use of such information may require a license from a third party under the patents or other intellectual property of the third party, or a license from TI under the patents or other intellectual property of TI.

Reproduction of TI information in TI data books or data sheets is permissible only if reproduction is without alteration and is accompanied by all associated warranties, conditions, limitations, and notices. Reproduction of this information with alteration is an unfair and deceptive business practice. TI is not responsible or liable for such altered documentation. Information of third parties may be subject to additional restrictions.

Resale of TI products or services with statements different from or beyond the parameters stated by TI for that product or service voids all express and any implied warranties for the associated TI product or service and is an unfair and deceptive business practice. TI is not responsible or liable for any such statements.

TI products are not authorized for use in safety-critical applications (such as life support) where a failure of the TI product would reasonably be expected to cause severe personal injury or death, unless officers of the parties have executed an agreement specifically governing such use. Buyers represent that they have all necessary expertise in the safety and regulatory ramifications of their applications, and acknowledge and agree that they are solely responsible for all legal, regulatory and safety-related requirements concerning their products and any use of TI products in such safety-critical applications, notwithstanding any applications-related information or support that may be provided by TI. Further, Buyers must fully indemnify TI and its representatives against any damages arising out of the use of TI products in such safety-critical applications.

TI products are neither designed nor intended for use in military/aerospace applications or environments unless the TI products are specifically designated by TI as military-grade or "enhanced plastic." Only products designated by TI as military-grade meet military specifications. Buyers acknowledge and agree that any such use of TI products which TI has not designated as military-grade is solely at the Buyer's risk, and that they are solely responsible for compliance with all legal and regulatory requirements in connection with such use.

TI products are neither designed nor intended for use in automotive applications or environments unless the specific TI products are designated by TI as compliant with ISO/TS 16949 requirements. Buyers acknowledge and agree that, if they use any non-designated products in automotive applications, TI will not be responsible for any failure to meet such requirements.

Following are URLs where you can obtain information on other Texas Instruments products and application solutions:

### Products

Amplifiers	<a href="http://amplifier.ti.com">amplifier.ti.com</a>
Data Converters	<a href="http://dataconverter.ti.com">dataconverter.ti.com</a>
DSP	<a href="http://dsp.ti.com">dsp.ti.com</a>
Clocks and Timers	<a href="http://www.ti.com/clocks">www.ti.com/clocks</a>
Interface	<a href="http://interface.ti.com">interface.ti.com</a>
Logic	<a href="http://logic.ti.com">logic.ti.com</a>
Power Mgmt	<a href="http://power.ti.com">power.ti.com</a>
Microcontrollers	<a href="http://microcontroller.ti.com">microcontroller.ti.com</a>
RFID	<a href="http://www.ti-rfid.com">www.ti-rfid.com</a>
RF/IF and ZigBee® Solutions	<a href="http://www.ti.com/lprf">www.ti.com/lprf</a>

### Applications

Audio	<a href="http://www.ti.com/audio">www.ti.com/audio</a>
Automotive	<a href="http://www.ti.com/automotive">www.ti.com/automotive</a>
Broadband	<a href="http://www.ti.com/broadband">www.ti.com/broadband</a>
Digital Control	<a href="http://www.ti.com/digitalcontrol">www.ti.com/digitalcontrol</a>
Medical	<a href="http://www.ti.com/medical">www.ti.com/medical</a>
Military	<a href="http://www.ti.com/military">www.ti.com/military</a>
Optical Networking	<a href="http://www.ti.com/opticalnetwork">www.ti.com/opticalnetwork</a>
Security	<a href="http://www.ti.com/security">www.ti.com/security</a>
Telephony	<a href="http://www.ti.com/telephony">www.ti.com/telephony</a>
Video & Imaging	<a href="http://www.ti.com/video">www.ti.com/video</a>
Wireless	<a href="http://www.ti.com/wireless">www.ti.com/wireless</a>

Mailing Address: Texas Instruments, Post Office Box 655303, Dallas, Texas 75265  
Copyright © 2008, Texas Instruments Incorporated