

# SN54ABT8646, SN74ABT8646 SCAN TEST DEVICES WITH OCTAL BUS TRANSCEIVERS AND REGISTERS

SCBS123F – AUGUST 1992 – REVISED APRIL 2004

- Members of the Texas Instruments **SCOPE™** Family of Testability Products
- Compatible With the IEEE Standard 1149.1-1990 (JTAG) Test Access Port and Boundary-Scan Architecture
- Functionally Equivalent to 'F646 and 'ABT646 in the Normal-Function Mode
- **SCOPE™** Instruction Set
  - IEEE Standard 1149.1-1990 Required Instructions, Optional INTEST, CLAMP, and HIGHZ
  - Parallel-Signature Analysis at Inputs With Masking Option
  - Pseudorandom Pattern Generation From Outputs
  - Sample Inputs/Toggle Outputs
  - Binary Count From Outputs
  - Even-Parity Opcodes
- Two Boundary-Scan Cells Per I/O for Greater Flexibility
- State-of-the-Art **EPIC-II B™** BiCMOS Design Significantly Reduces Power Dissipation
- Package Options Include Plastic Small-Outline (DW) and Shrink Small-Outline (DL) Packages, Ceramic Chip Carriers (FK), and Standard Ceramic DIPs (JT)

## description

The 'ABT8646 and scan-test devices with octal bus transceivers and registers are members of the Texas Instruments **SCOPE™** testability integrated-circuit family. This family of devices supports IEEE Standard 1149.1-1990 boundary scan to facilitate testing of complex circuit-board assemblies. Scan access to the test circuitry is accomplished via the 4-wire test access port (TAP) interface.

In the normal mode, these devices are functionally equivalent to the 'F646 and 'ABT646 octal bus transceivers and registers. The test circuitry can be activated by the TAP to take snapshot samples of the data appearing at the device pins or to perform a self-test on the boundary-test cells. Activating the TAP in normal mode does not affect the functional operation of the **SCOPE™** octal bus transceivers and registers.

SN54ABT8646 . . . JT PACKAGE  
SN74ABT8646 . . . DL OR DW PACKAGE  
(TOP VIEW)

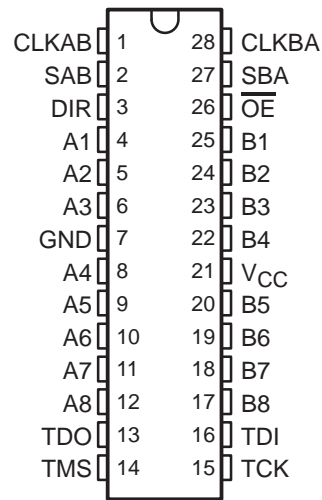

SN54ABT8646 . . . FK PACKAGE  
(TOP VIEW)

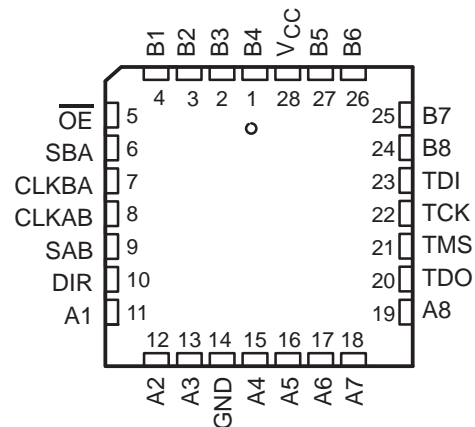

Please be aware that an important notice concerning availability, standard warranty, and use in critical applications of Texas Instruments semiconductor products and disclaimers thereto appears at the end of this data sheet.

SCOPE and EPIC-II B are trademarks of Texas Instruments.

PRODUCTION DATA information is current as of publication date. Products conform to specifications per the terms of Texas Instruments standard warranty. Production processing does not necessarily include testing of all parameters.



POST OFFICE BOX 655303 • DALLAS, TEXAS 75265

Copyright © 2004, Texas Instruments Incorporated  
On products compliant to MIL-PRF-38535, all parameters are tested unless otherwise noted. On all other products, production processing does not necessarily include testing of all parameters.

# SN54ABT8646, SN74ABT8646 SCAN TEST DEVICES WITH OCTAL BUS TRANSCEIVERS AND REGISTERS

SCBS123F – AUGUST 1992 – REVISED APRIL 2004

## description (continued)

Transceiver function is controlled by output-enable ( $\overline{OE}$ ) and direction (DIR) inputs. When  $\overline{OE}$  is low, the transceiver is active and operates in the A-to-B direction when DIR is high or in the B-to-A direction when DIR is low. When  $\overline{OE}$  is high, both the A and B outputs are in the high-impedance state, effectively isolating both buses.

Data flow is controlled by clock (CLKAB and CLKBA) and select (SAB and SBA) inputs. Data on the A bus is clocked into the associated registers on the low-to-high transition of CLKAB. When SAB is low, real-time A data is selected for presentation to the B bus (transparent mode). When SAB is high, stored A data is selected for presentation to the B bus (registered mode). The function of the CLKBA and SBA inputs mirrors that of CLKAB and SAB, respectively. Figure 1 shows the four fundamental bus-management functions that can be performed with the 'ABT8646.

In the test mode, the normal operation of the SCOPE™ bus transceivers and registers is inhibited, and the test circuitry is enabled to observe and control the I/O boundary of the device. When enabled, the test circuitry performs boundary-scan test operations as described in IEEE Standard 1149.1-1990.

Four dedicated test pins control the operation of the test circuitry: test data input (TDI), test data output (TDO), test mode select (TMS), and test clock (TCK). Additionally, the test circuitry performs other testing functions such as parallel-signature analysis (PSA) on data inputs and pseudorandom pattern generation (PRPG) from data outputs. All testing and scan operations are synchronized to the TAP interface.

The SN54ABT8646 is characterized for operation over the full military temperature range of  $-55^{\circ}\text{C}$  to  $125^{\circ}\text{C}$ . The SN74ABT8646 is characterized for operation from  $-40^{\circ}\text{C}$  to  $85^{\circ}\text{C}$ .

FUNCTION TABLE

INPUTS						DATA I/O		OPERATION OR FUNCTION
$\overline{OE}$	DIR	CLKAB	CLKBA	SAB	SBA	A1–A8	B1–B8	
X	X	↑	X	X	X	Input	Unspecified†	Store A, B unspecified†
X	X	X	↑	X	X	Unspecified†	Input	Store B, A unspecified†
H	X	↑	↑	X	X	Input	Input	Store A and B data
H	X	H or L	H or L	X	X	Input disabled	Input disabled	Isolation, hold storage
L	L	X	X	X	L	Output	Input	Real-time B data to A bus
L	L	X	H or L	X	H	Output	Input disabled	Stored B data to A bus
L	H	X	X	L	X	Input	Output	Real-time A data to B bus
L	H	H or L	X	H	X	Input disabled	Output	Stored A data to B bus

† The data-output functions can be enabled or disabled by various signals at  $\overline{OE}$  and DIR. Data-input functions are always enabled; i.e., data at the bus pins is stored on every low-to-high transition of the clock inputs.

**SN54ABT8646, SN74ABT8646**  
**SCAN TEST DEVICES WITH**  
**OCTAL BUS TRANSCEIVERS AND REGISTERS**

SCBS123F – AUGUST 1992 – REVISED APRIL 2004

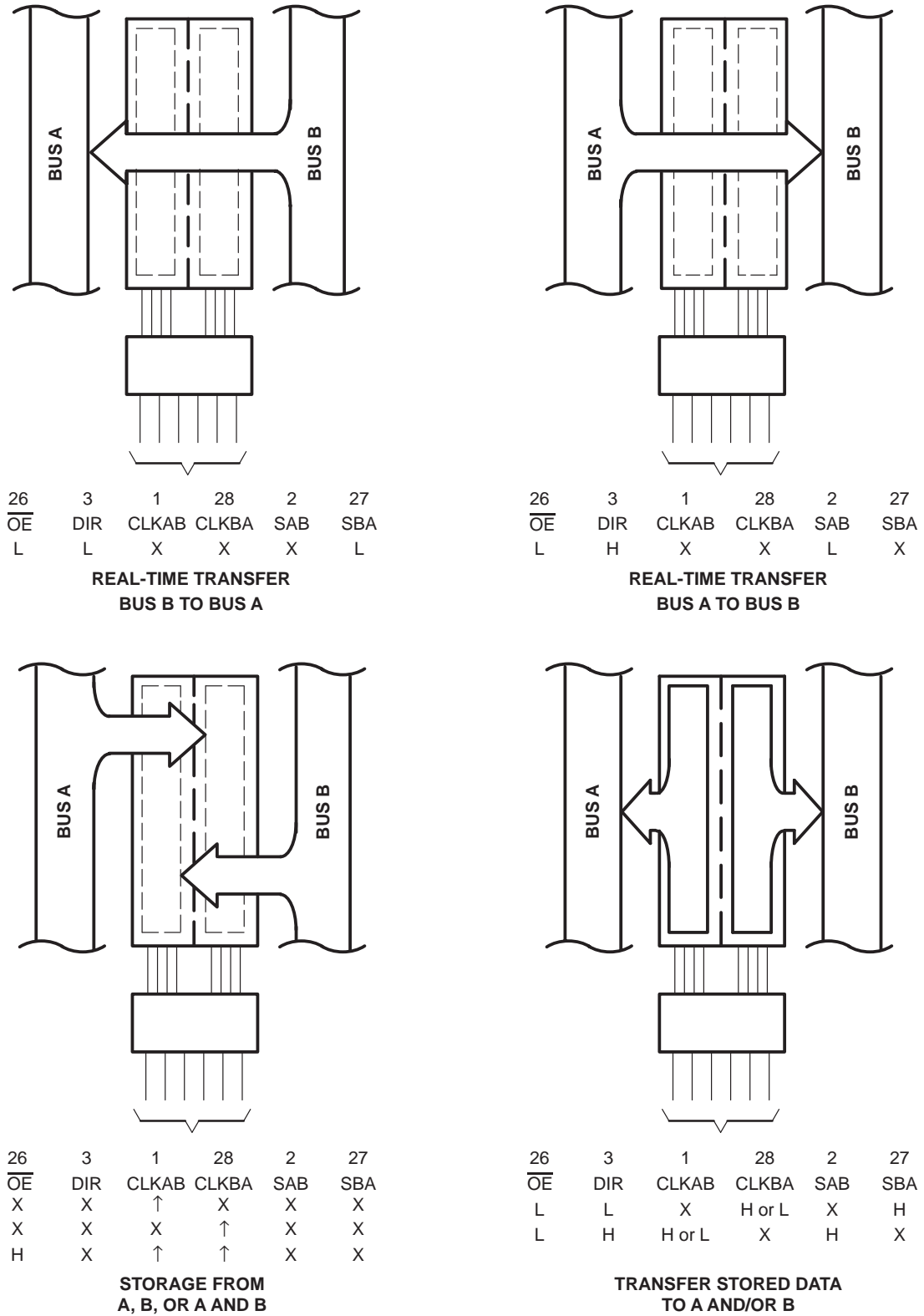

Pin numbers shown are for the DL, DW, and JT packages.

**Figure 1. Bus-Management Functions**

# SN54ABT8646, SN74ABT8646 SCAN TEST DEVICES WITH OCTAL BUS TRANSCEIVERS AND REGISTERS

SCBS123F – AUGUST 1992 – REVISED APRIL 2004

## functional block diagram

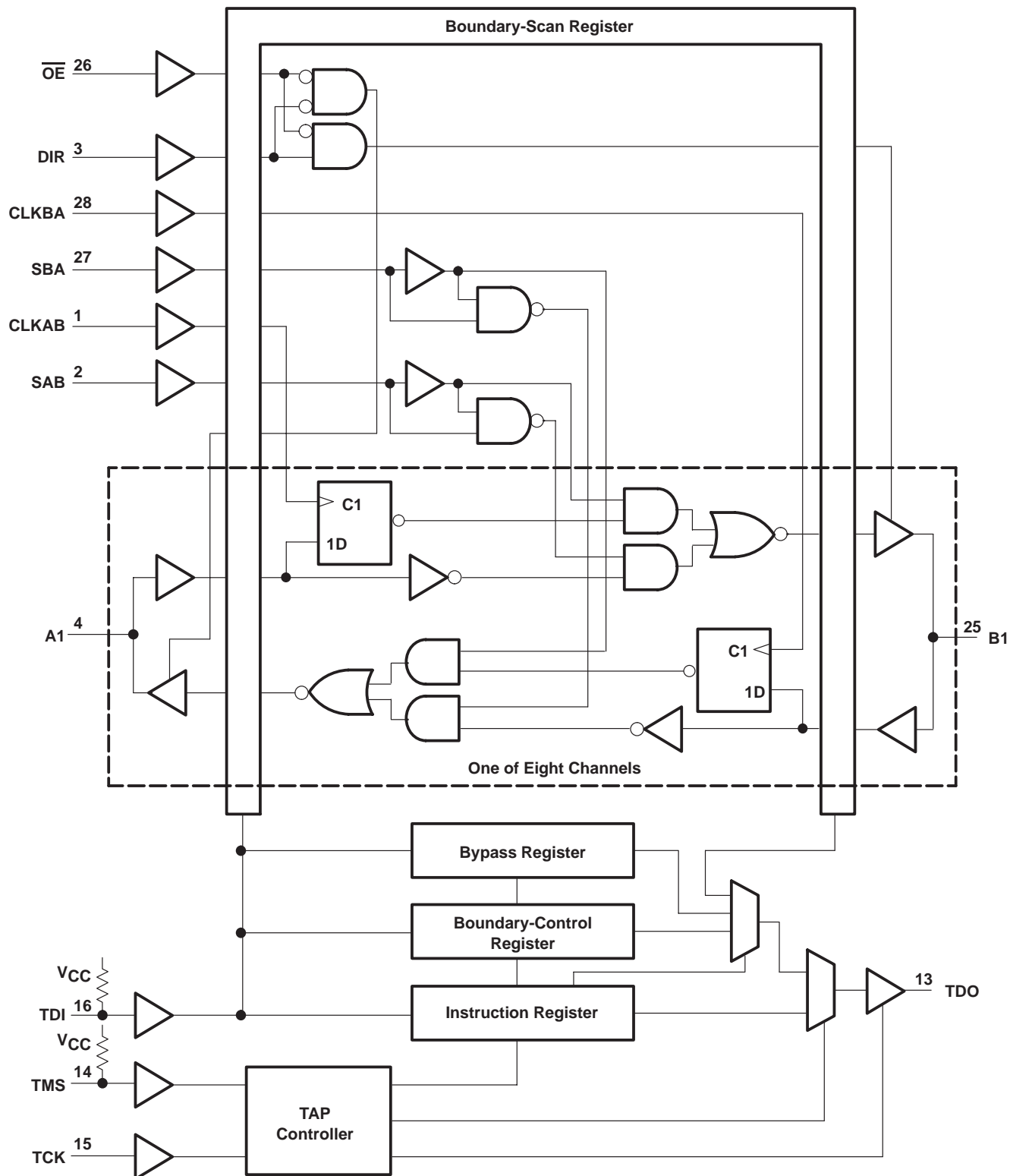

Pin numbers shown for the DL, DW, and JT packages.

### Terminal Functions

TERMINAL NAME	DESCRIPTION
A1–A8	Normal-function A-bus I/O ports. See function table for normal-mode logic.
B1–B8	Normal-function B-bus I/O ports. See function table for normal-mode logic.
CLKAB, CLKBA	Normal-function clock inputs. See function table for normal-mode logic.
DIR	Normal-function direction-control input. See function table for normal-mode logic.
GND	Ground
$\overline{OE}$	Normal-function output-enable input. See function table for normal-mode logic.
SAB, SBA	Normal-function select inputs. See function table for normal-mode logic.
TCK	Test clock. One of four terminals required by IEEE Standard 1149.1-1990. Test operations of the device are synchronous to TCK. Data is captured on the rising edge of TCK, and outputs change on the falling edge of TCK.
TDI	Test data input. One of four terminals required by IEEE Standard 1149.1-1990. TDI is the serial input for shifting data through the instruction register or selected data register. An internal pullup forces TDI to a high level if left unconnected.
TDO	Test data output. One of four terminals required by IEEE Standard 1149.1-1990. TDO is the serial output for shifting data through the instruction register or selected data register.
TMS	Test mode select. One of four terminals required by IEEE Standard 1149.1-1990. TMS input directs the device through its TAP controller states. An internal pullup forces TMS to a high level if left unconnected.
V <sub>CC</sub>	Supply voltage

# SN54ABT8646, SN74ABT8646 SCAN TEST DEVICES WITH OCTAL BUS TRANSCEIVERS AND REGISTERS

SCBS123F – AUGUST 1992 – REVISED APRIL 2004

## test architecture

Serial-test information is conveyed by means of a 4-wire test bus or TAP, that conforms to IEEE Standard 1149.1-1990. Test instructions, test data, and test control signals all are passed along this serial-test bus. The TAP controller monitors two signals from the test bus, TCK and TMS. The TAP controller extracts the synchronization (TCK) and state control (TMS) signals from the test bus and generates the appropriate on-chip control signals for the test structures in the device. Figure 2 shows the TAP-controller state diagram.

The TAP controller is fully synchronous to the TCK signal. Input data is captured on the rising edge of TCK and output data changes on the falling edge of TCK. This scheme ensures that data to be captured is valid for fully one-half of the TCK cycle.

The functional block diagram shows the IEEE Standard 1149.1-1990 4-wire test bus and boundary-scan architecture and the relationship among the test bus, the TAP controller, and the test registers. As shown, the device contains an 8-bit instruction register and three test-data registers: a 40-bit boundary-scan register, an 11-bit boundary-control register, and a 1-bit bypass register.

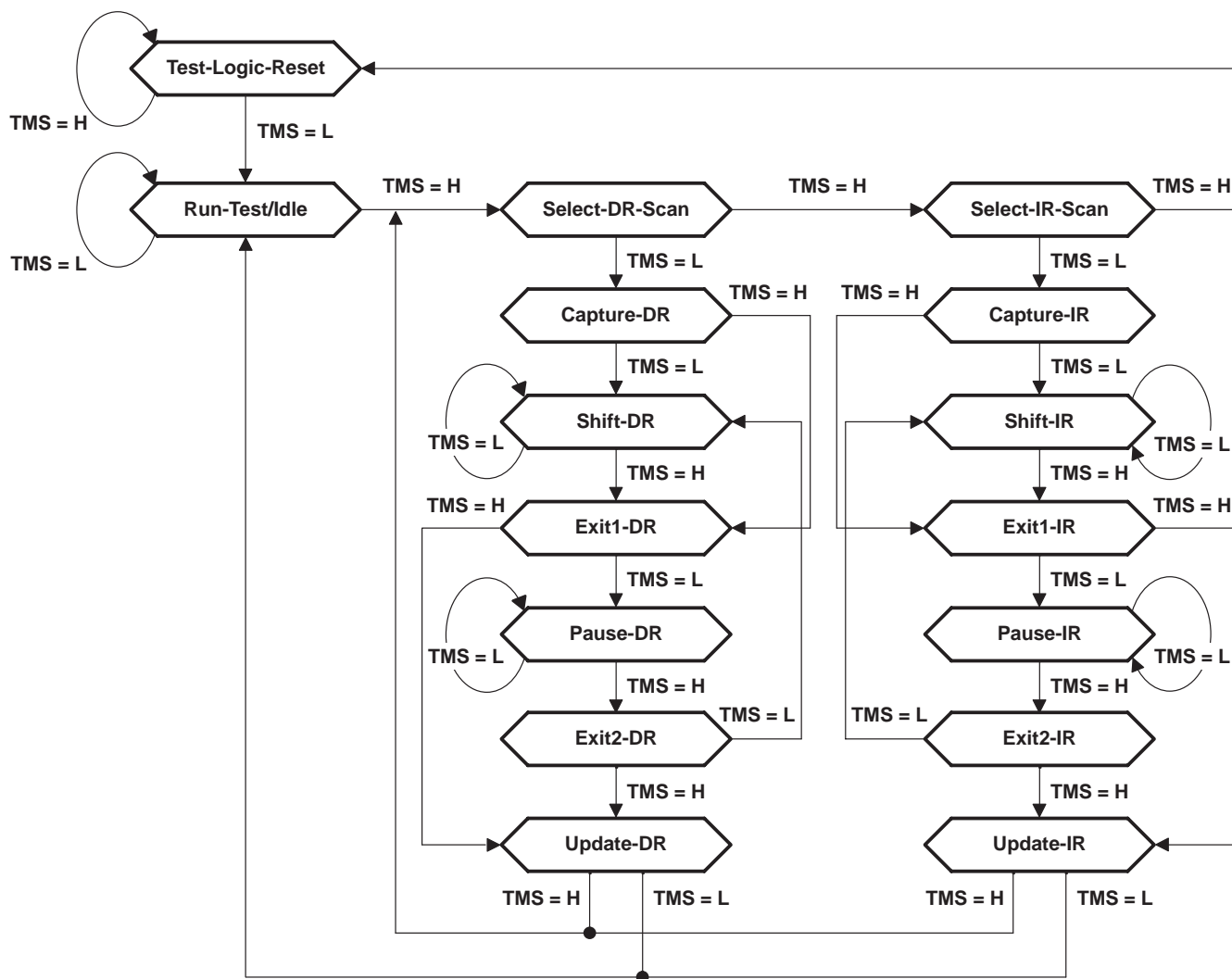

Figure 2. TAP-Controller State Diagram

## state diagram description

The TAP controller is a synchronous finite-state machine that provides test control signals throughout the device. The state diagram shown in Figure 2 is in accordance with IEEE Standard 1149.1-1990. The TAP controller proceeds through its states, based on the level of TMS at the rising edge of TCK.

As shown, the TAP controller consists of 16 states. There are six stable states (indicated by a looping arrow in the state diagram) and ten unstable states. A stable state is a state the TAP controller can retain for consecutive TCK cycles. Any state that does not meet this criterion is an unstable state.

There are two main paths through the state diagram: one to access and control the selected data register and one to access and control the instruction register. Only one register can be accessed at a time.

### Test-Logic-Reset

The device powers up in the Test-Logic-Reset state. In the stable Test-Logic-Reset state, the test logic is reset and is disabled so that the normal logic function of the device is performed. The instruction register is reset to an opcode that selects the optional IDCODE instruction, if supported, or the BYPASS instruction. Certain data registers also can be reset to their power-up values.

The state machine is constructed such that the TAP controller returns to the Test-Logic-Reset state in no more than five TCK cycles if TMS is left high. The TMS pin has an internal pullup resistor that forces it high if left unconnected or if a board defect causes it to be open circuited.

For the 'ABT8646, the instruction register is reset to the binary value 11111111, which selects the BYPASS instruction. Each bit in the boundary-scan register is reset to logic 0. The boundary-control register is reset to the binary value 0000000010, which selects the PSA test operation, with no input masking.

### Run-Test/Idle

The TAP controller must pass through the Run-Test/Idle state (from Test-Logic-Reset) before executing any test operations. The Run-Test/Idle state also can be entered following data-register or instruction-register scans. Run-Test/Idle is a stable state in which the test logic actively can be running a test or can be idle.

The test operations selected by the boundary-control register are performed while the TAP controller is in the Run-Test/Idle state.

### Select-DR-Scan, Select-IR-Scan

No specific function is performed in the Select-DR-Scan and Select-IR-Scan states, and the TAP controller exits either of these states on the next TCK cycle. These states allow the selection of either data-register scan or instruction-register scan.

### Capture-DR

When a data-register scan is selected, the TAP controller must pass through the Capture-DR state. In the Capture-DR state, the selected data register can capture a data value as specified by the current instruction. Such capture operations occur on the rising edge of TCK, upon which the TAP controller exits the Capture-DR state.

### Shift-DR

Upon entry to the Shift-DR state, the data register is placed in the scan path between TDI and TDO and, on the first falling edge of TCK, TDO goes from the high-impedance state to an active state. TDO enables to the logic level present in the least-significant bit of the selected data register.

While in the stable Shift-DR state, data is serially shifted through the selected data register on each TCK cycle. The first shift occurs on the first rising edge of TCK after entry to the Shift-DR state (i.e., no shifting occurs during the TCK cycle in which the TAP controller changes from Capture-DR to Shift-DR or from Exit2-DR to Shift-DR). The last shift occurs on the rising edge of TCK, upon which the TAP controller exits the Shift-DR state.

# SN54ABT8646, SN74ABT8646 SCAN TEST DEVICES WITH OCTAL BUS TRANSCEIVERS AND REGISTERS

SCBS123F – AUGUST 1992 – REVISED APRIL 2004

---

## Exit1-DR, Exit2-DR

The Exit1-DR and Exit2-DR states are temporary states that end a data-register scan. It is possible to return to the Shift-DR state from either Exit1-DR or Exit2-DR without recapturing the data register.

On the first falling edge of TCK after entry to Exit1-DR, TDO goes from the active state to the high-impedance state.

## Pause-DR

No specific function is performed in the stable Pause-DR state, in which the TAP controller can remain indefinitely. The Pause-DR state suspends and resumes data-register scan operations without loss of data.

## Update-DR

If the current instruction calls for the selected data register to be updated with current data, then such update occurs on the falling edge of TCK, following entry to the Update-DR state.

## Capture-IR

When an instruction-register scan is selected, the TAP controller must pass through the Capture-IR state. In the Capture-IR state, the instruction register captures its current status value. This capture operation occurs on the rising edge of TCK upon, which the TAP controller exits the Capture-IR state.

For the 'ABT8646, the status value loaded in the Capture-IR state is the fixed binary value 10000001.

## Shift-IR

Upon entry to the Shift-IR state, the instruction register is placed in the scan path between TDI and TDO and, on the first falling edge of TCK, TDO goes from the high-impedance state to an active state. TDO enables to the logic level present in the least-significant bit of the instruction register.

While in the stable Shift-IR state, instruction data is serially shifted through the instruction register on each TCK cycle. The first shift occurs on the first rising edge of TCK after entry to the Shift-IR state (i.e., no shifting occurs during the TCK cycle in which the TAP controller changes from Capture-IR to Shift-IR or from Exit2-IR to Shift-IR). The last shift occurs on the rising edge of TCK, upon which the TAP controller exits the Shift-IR state.

## Exit1-IR, Exit2-IR

The Exit1-IR and Exit2-IR states are temporary states that end an instruction-register scan. It is possible to return to the Shift-IR state from either Exit1-IR or Exit2-IR without recapturing the instruction register.

On the first falling edge of TCK after entry to Exit1-IR, TDO goes from the active state to the high-impedance state.

## Pause-IR

No specific function is performed in the stable Pause-IR state, in which the TAP controller can remain indefinitely. The Pause-IR state suspends and resumes instruction-register scan operations without loss of data.

## Update-IR

The current instruction is updated and takes effect on the falling edge of TCK, following entry to the Update-IR state.



## register overview

With the exception of the bypass register, any test register can be thought of as a serial-shift register with a shadow latch on each bit. The bypass register differs in that it contains only a shift register. During the appropriate capture state (Capture-IR for instruction register, Capture-DR for data registers), the shift register can be parallel loaded from a source specified by the current instruction. During the appropriate shift state (Shift-IR or Shift-DR), the contents of the shift register are shifted out from TDO while new contents are shifted in at TDI. During the appropriate update state (Update-IR or Update-DR), the shadow latches are updated from the shift register.

## instruction register description

The instruction register (IR) is eight bits long and tells the device what instruction is to be executed. Information contained in the instruction includes the mode of operation (either normal mode, in which the device performs its normal logic function, or test mode, in which the normal logic function is inhibited or altered), the test operation to be performed, which of the three data registers is to be selected for inclusion in the scan path during data-register scans, and the source of data to be captured into the selected data register during Capture-DR.

Table 3 lists the instructions supported by the 'ABT8646. The even-parity feature specified for SCOPE™ devices is supported in this device. Bit 7 of the instruction opcode is the parity bit. Any instructions that are defined for SCOPE™ devices but are not supported by this device default to BYPASS.

During Capture-IR, the IR captures the binary value 10000001. As an instruction is shifted in, this value is shifted out via TDO and can be inspected as verification that the IR is in the scan path. During Update-IR, the value that has been shifted into the IR is loaded into shadow latches. At this time, the current instruction is updated, and any specified mode change takes effect. At power up or in the Test-Logic-Reset state, the IR is reset to the binary value 11111111, which selects the BYPASS instruction. The IR order of scan is shown in Figure 3.



**Figure 3. Instruction Register Order of Scan**

# SN54ABT8646, SN74ABT8646 SCAN TEST DEVICES WITH OCTAL BUS TRANSCEIVERS AND REGISTERS

SCBS123F – AUGUST 1992 – REVISED APRIL 2004

## data register description

### boundary-scan register

The boundary-scan register (BSR) is 40 bits long. It contains one boundary-scan cell (BSC) for each normal-function input pin, two BSCs for each normal-function I/O pin (one for input data and one for output data), and one BSC for each of the internally decoded output-enable signals (OEA and OEB). The BSR is used 1) to store test data that is to be applied internally to the inputs of the normal on-chip logic and/or externally to the device output pins, and/or 2) to capture data that appears internally at the outputs of the normal on-chip logic and/or externally at the device input pins.

The source of data to be captured into the BSR during Capture-DR is determined by the current instruction. The contents of the BSR can change during Run-Test/Idle as determined by the current instruction. At power up or in Test-Logic-Reset, the value of each BSC is reset to logic 0.

When external data is to be captured, the BSCs for signals OEA and OEB capture logic values determined by the following positive-logic equations:  $OEA = \overline{OE} \cdot \overline{DIR}$ , and  $OEB = \overline{OE} \cdot DIR$ . When data is to be applied externally, these BSCs control the drive state (active or high-impedance) of their respective outputs.

The BSR order of scan is from TDI through bits 39–0 to TDO. Table 1 shows the BSR bits and their associated device pin signals.

**Table 1. Boundary-Scan Register Configuration**

BSR BIT NUMBER	DEVICE SIGNAL	BSR BIT NUMBER	DEVICE SIGNAL	BSR BIT NUMBER	DEVICE SIGNAL	BSR BIT NUMBER	DEVICE SIGNAL	BSR BIT NUMBER	DEVICE SIGNAL
39	OEB	31	A8-I	23	A8-O	15	B8-I	7	B8-O
38	OEA	30	A7-I	22	A7-O	14	B7-I	6	B7-O
37	DIR	29	A6-I	21	A6-O	13	B6-I	5	B6-O
36	$\overline{OE}$	28	A5-I	20	A5-O	12	B5-I	4	B5-O
35	CLKAB	27	A4-I	19	A4-O	11	B4-I	3	B4-O
34	CLKBA	26	A3-I	18	A3-O	10	B3-I	2	B3-O
33	SAB	25	A2-I	17	A2-O	9	B2-I	1	B2-O
32	SBA	24	A1-I	16	A1-O	8	B1-I	0	B1-O

**boundary-control register**

The boundary-control register (BCR) is 11 bits long. The BCR is used in the context of the RUNT instruction to implement additional test operations not included in the basic SCOPE™ instruction set. Such operations include PRPG, PSA with input masking, and binary count up (COUNT). Table 4 shows the test operations that are decoded by the BCR.

During Capture-DR, the contents of the BCR are not changed. At power up or in Test-Logic-Reset, the BCR is reset to the binary value 0000000010, which selects the PSA test operation with no input masking.

The BCR order of scan is from TDI through bits 10–0 to TDO. Table 2 shows the BCR bits and their associated test control signals.

**Table 2. Boundary-Control Register Configuration**

BCR BIT NUMBER	TEST CONTROL SIGNAL	BCR BIT NUMBER	TEST CONTROL SIGNAL	BCR BIT NUMBER	TEST CONTROL SIGNAL
10	MASK8	6	MASK4	2	OPCODE2
9	MASK7	5	MASK3	1	OPCODE1
8	MASK6	4	MASK2	0	OPCODE0
7	MASK5	3	MASK1	--	--

**bypass register**

The bypass register is a 1-bit scan path that can be selected to shorten the length of the system scan path, thereby reducing the number of bits per test pattern that must be applied to complete a test operation. During Capture-DR, the bypass register captures a logic 0. The bypass register order of scan is shown in Figure 4.

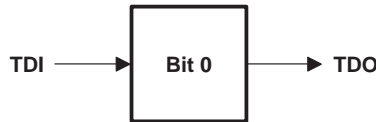

**Figure 4. Bypass Register Order of Scan**

# SN54ABT8646, SN74ABT8646 SCAN TEST DEVICES WITH OCTAL BUS TRANSCEIVERS AND REGISTERS

SCBS123F – AUGUST 1992 – REVISED APRIL 2004

## instruction-register opcode description

The instruction-register opcodes are shown in Table 3. The following descriptions detail the operation of each instruction.

**Table 3. Instruction-Register Opcodes**

BINARY CODE† BIT 7 → BIT 0 MSB → LSB	SCOPE OPCODE	DESCRIPTION	SELECTED DATA REGISTER	MODE
00000000	EXTEST/INTEST	Boundary scan	Boundary scan	Test
10000001	BYPASS‡	Bypass scan	Bypass	Normal
10000010	SAMPLE/PRELOAD	Sample boundary	Boundary scan	Normal
00000011	INTEST/EXTEST	Boundary scan	Boundary scan	Test
10000100	BYPASS‡	Bypass scan	Bypass	Normal
00000101	BYPASS‡	Bypass scan	Bypass	Normal
00000110	HIGHZ	Control boundary to high impedance	Bypass	Modified test
10000111	CLAMP	Control boundary to 1/0	Bypass	Test
10001000	BYPASS‡	Bypass scan	Bypass	Normal
00001001	RUNT	Boundary run test	Bypass	Test
00001010	READBN	Boundary read	Boundary scan	Normal
10001011	READBT	Boundary read	Boundary scan	Test
00001100	CELLTST	Boundary self test	Boundary scan	Normal
10001101	TOPHIP	Boundary toggle outputs	Bypass	Test
10001110	SCANCN	Boundary-control register scan	Boundary control	Normal
00001111	SCANCT	Boundary-control register scan	Boundary control	Test
All others	BYPASS	Bypass scan	Bypass	Normal

† Bit 7 is used to maintain even parity in the 8-bit instruction.

‡ The BYPASS instruction is executed in lieu of a SCOPE™ instruction that is not supported in the 'ABT8646.

### boundary scan

This instruction conforms to the IEEE Standard 1149.1-1990 EXTEST and INTEST instructions. The BSR is selected in the scan path. Data appearing at the device input pins is captured in the input BSCs, while data appearing at the outputs of the normal on-chip logic is captured in the output BSCs. Data that has been scanned into the input BSCs is applied to the inputs of the normal on-chip logic, while data that has been scanned into the output BSCs is applied to the device output pins. The device operates in the test mode.

### bypass scan

This instruction conforms to the IEEE Standard 1149.1-1990 BYPASS instruction. The bypass register is selected in the scan path. A logic 0 value is captured in the bypass register during Capture-DR. The device operates in the normal mode.

### sample boundary

This instruction conforms to the IEEE Standard 1149.1-1990 SAMPLE/PRELOAD instruction. The BSR is selected in the scan path. Data appearing at the device input pins is captured in the input BSCs, while data appearing at the outputs of the normal on-chip logic is captured in the output BSCs. The device operates in the normal mode.



POST OFFICE BOX 655303 • DALLAS, TEXAS 75265

**control boundary to high impedance**

This instruction conforms to the IEEE Standard 1149.1a-1993 HIGHZ instruction. The bypass register is selected in the scan path. A logic 0 value is captured in the bypass register during Capture-DR. The device operates in a modified test mode in which all device I/O pins are placed in the high-impedance state, the device input pins remain operational, and the normal on-chip logic function is performed.

**control boundary to 1/0**

This instruction conforms to the IEEE Standard 1149.1a-1993 CLAMP instruction. The bypass register is selected in the scan path. A logic 0 value is captured in the bypass register during Capture-DR. Data in the input BSCs is applied to the inputs of the normal on-chip logic, while data in the output BSCs is applied to the device output pins. The device operates in the test mode.

**boundary run test**

The bypass register is selected in the scan path. A logic 0 value is captured in the bypass register during Capture-DR. The device operates in the test mode. The test operation specified in the BCR is executed during Run-Test/Idle. The five test operations decoded by the BCR are: sample inputs/toggle outputs (TOPSIP), PRPG, PSA, simultaneous PSA and PRPG (PSA/PRPG), and simultaneous PSA and binary count up (PSA/COUNT).

**boundary read**

The BSR is selected in the scan path. The value in the BSR remains unchanged during Capture-DR. This instruction is useful for inspecting data after a PSA operation.

**boundary self test**

The BSR is selected in the scan path. All BSCs capture the inverse of their current values during Capture-DR. In this way, the contents of the shadow latches can be read out to verify the integrity of both shift-register and shadow-latch elements of the BSR. The device operates in the normal mode.

**boundary toggle outputs**

The bypass register is selected in the scan path. A logic 0 value is captured in the bypass register during Capture-DR. Data in the shift-register elements of the selected output BSCs is toggled on each rising edge of TCK in Run-Test/Idle, updated in the shadow latches, and applied to the associated device output pins on each falling edge of TCK in Run-Test/Idle. Data in the selected input BSCs remains constant and is applied to the inputs of the normal on-chip logic. Data appearing at the device input pins is not captured in the input BSCs. The device operates in the test mode.

**boundary-control-register scan**

The BCR is selected in the scan path. The value in the BCR remains unchanged during Capture-DR. This operation must be performed before a boundary-run test operation to specify which test operation is to be executed.

# SN54ABT8646, SN74ABT8646 SCAN TEST DEVICES WITH OCTAL BUS TRANSCEIVERS AND REGISTERS

SCBS123F – AUGUST 1992 – REVISED APRIL 2004

## boundary-control-register opcode description

The BCR opcodes are decoded from BCR bits 2–0 as shown in Table 4. The selected test operation is performed while the RUNT instruction is executed in the Run-Test/Idle state. The following descriptions detail the operation of each BCR instruction and illustrate the associated PSA and PRPG algorithms.

**Table 4. Boundary-Control Register Opcodes**

<b>BINARY CODE BIT 2 → BIT 0 MSB → LSB</b>	<b>DESCRIPTION</b>
X00	Sample inputs/toggle outputs (TOPSIP)
X01	Pseudorandom pattern generation/16-bit mode (PRPG)
X10	Parallel-signature analysis/16-bit mode (PSA)
011	Simultaneous PSA and PRPG/8-bit mode (PSA/PRPG)
111	Simultaneous PSA and binary count up/8-bit mode (PSA/COUNT)

In general, while the control input BSCs (bits 39–32) are not included in the sample, toggle, PSA, PRPG, or COUNT algorithms, the output-enable BSCs (bits 39–38 of the BSR) do control the drive state (active or high impedance) of the selected device output pins. These BCR instructions are valid only when the device is operating in one direction of data flow (that is, OEA ≠ OEB). Otherwise, the bypass instruction is operated.

### PSA input masking

Bits 10–3 of the BCR specify device input pins to be masked from PSA operations. Bit 10 selects masking for device input pin A8 during A-to-B data flow or for device input pin B8 during B-to-A data flow. Bit 3 selects masking for device input pins A1 or B1 during A-to-B or B-to-A data flow, respectively. Bits intermediate to 10 and 3 mask corresponding device input pins, in order, from most significant to least significant, as indicated in Table 3. When the mask bit that corresponds to a particular device input has a logic 1 value, the device input pin is masked from any PSA operation, i.e., the state of the device input pin is ignored and has no effect on the generated signature. Otherwise, when a mask bit has a logic 0 value, the corresponding device input is not masked from the PSA operation.

### sample inputs/toggle outputs (TOPSIP)

Data appearing at the selected device input pins is captured in the shift-register elements of the selected BSCs on each rising edge of TCK. This data is updated in the shadow latches of the selected input BSCs and applied to the inputs of the normal on-chip logic. Data in the shift-register elements of the selected output BSCs is toggled on each rising edge of TCK, updated in the shadow latches, and applied to the associated device output pins on each falling edge of TCK.

**pseudorandom pattern generation (PRPG)**

A pseudorandom pattern is generated in the shift-register elements of the selected BSCs on each rising edge of TCK, updated in the shadow latches, and applied to the associated device output pins on each falling edge of TCK. This data also is updated in the shadow latches of the selected input BSCs and applied to the inputs of the normal on-chip logic. Figures 5 and 6 show the 16-bit linear-feedback shift-register algorithms through which the patterns are generated. An initial seed value should be scanned into the BSR before performing this operation. A seed value of all zeroes does not produce additional patterns.

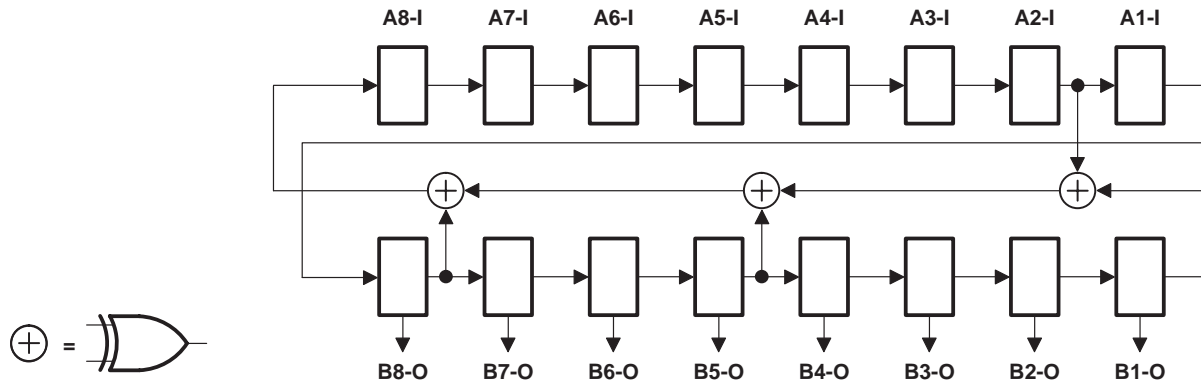

**Figure 5. 16-Bit PRPG Configuration (OEA = 0, OEB = 1)**

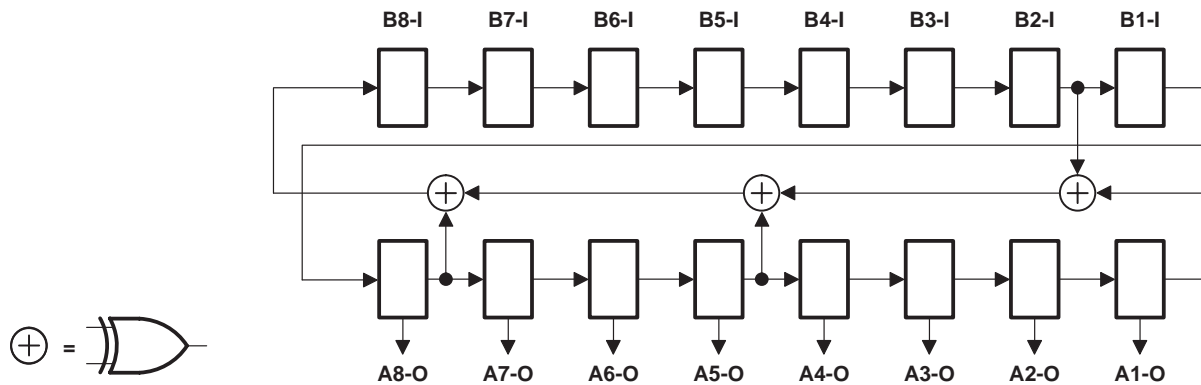

**Figure 6. 16-Bit PRPG Configuration (OEA=1, OEB= 0)**

# SN54ABT8646, SN74ABT8646 SCAN TEST DEVICES WITH OCTAL BUS TRANSCEIVERS AND REGISTERS

SCBS123F – AUGUST 1992 – REVISED APRIL 2004

## parallel-signature analysis (PSA)

Data appearing at the selected device input pins is compressed into a 16-bit parallel signature in the shift-register elements of the selected BSCs on each rising edge of TCK. This data is updated in the shadow latches of the selected input BSCs and applied to the inputs of the normal on-chip logic. Data in the shadow latches of the selected output BSCs remains constant and is applied to the device outputs. Figures 7 and 8 show the 16-bit linear-feedback shift-register algorithms through which the signature is generated. An initial seed value should be scanned into the BSR before performing this operation.

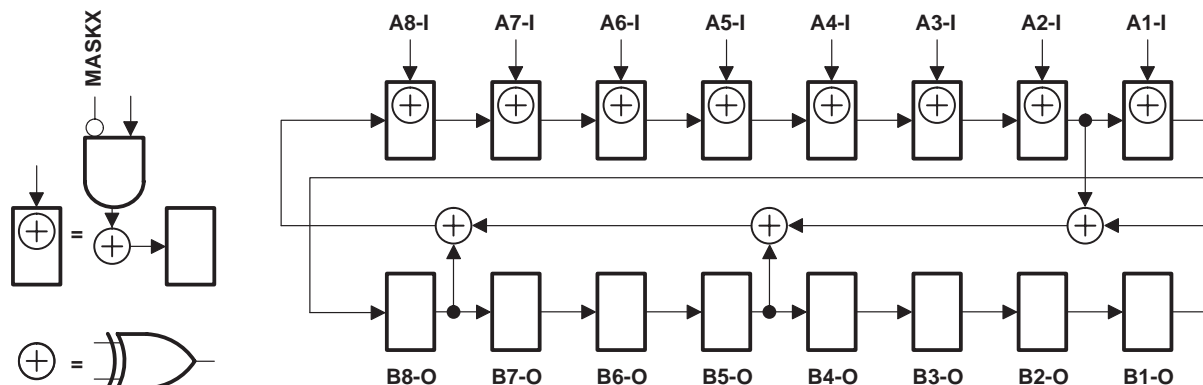

Figure 7. 16-Bit PSA Configuration (OEA = 0, OEB = 1)

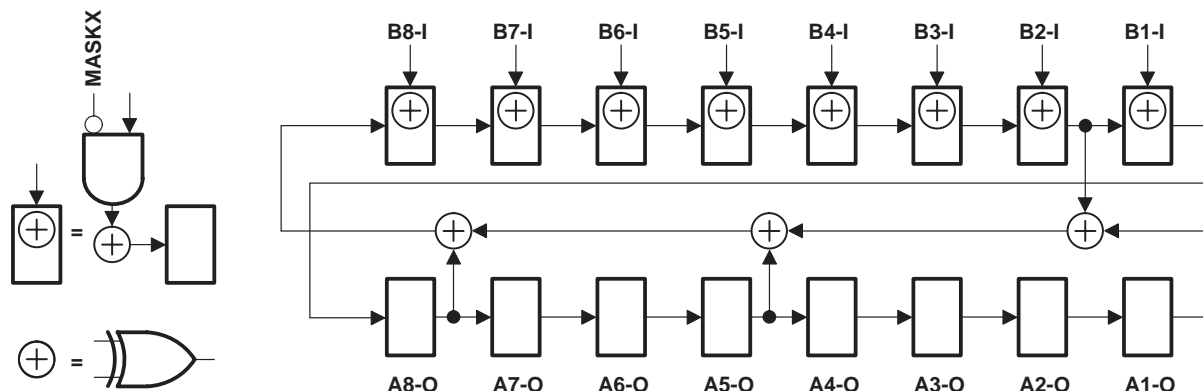
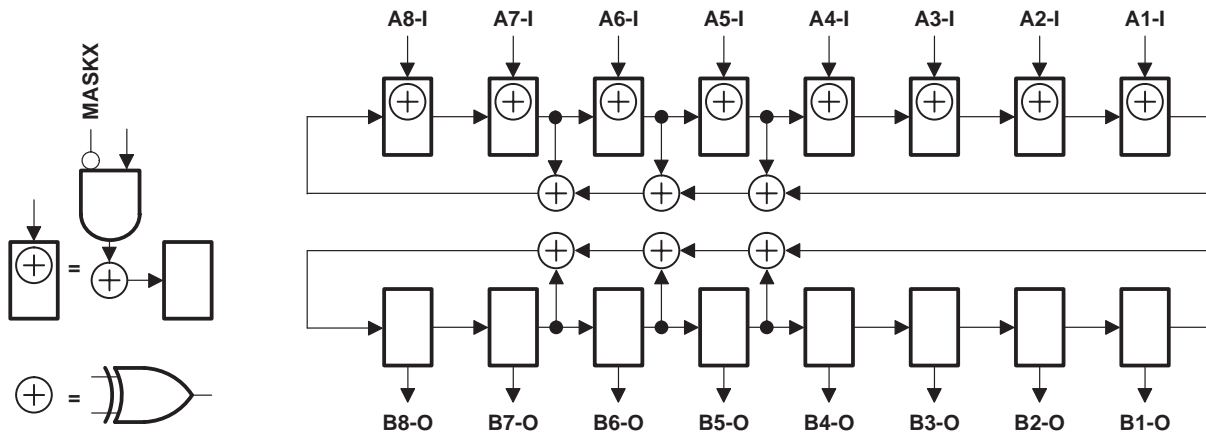

Figure 8. 16-Bit PSA Configuration (OEA = 1, OEB = 0)

**simultaneous PSA and PRPG (PSA/PRPG)**

Data appearing at the selected device input pins is compressed into an 8-bit parallel signature in the shift-register elements of the selected input BSCs on each rising edge of TCK. This data is updated in the shadow latches of the selected input BSCs and applied to the inputs of the normal on-chip logic. At the same time, an 8-bit pseudorandom pattern is generated in the shift-register elements of the selected output BSCs on each rising edge of TCK, updated in the shadow latches, and applied to the associated device output pins on each falling edge of TCK. Figures 9 and 10 show the 8-bit linear-feedback shift-register algorithms through which the signature and patterns are generated. An initial seed value should be scanned into the BSR before performing this operation. A seed value of all zeroes does not produce additional patterns.



**Figure 9. 8-Bit PSA/PRPG Configuration (OEA = 0, OEB = 1)**

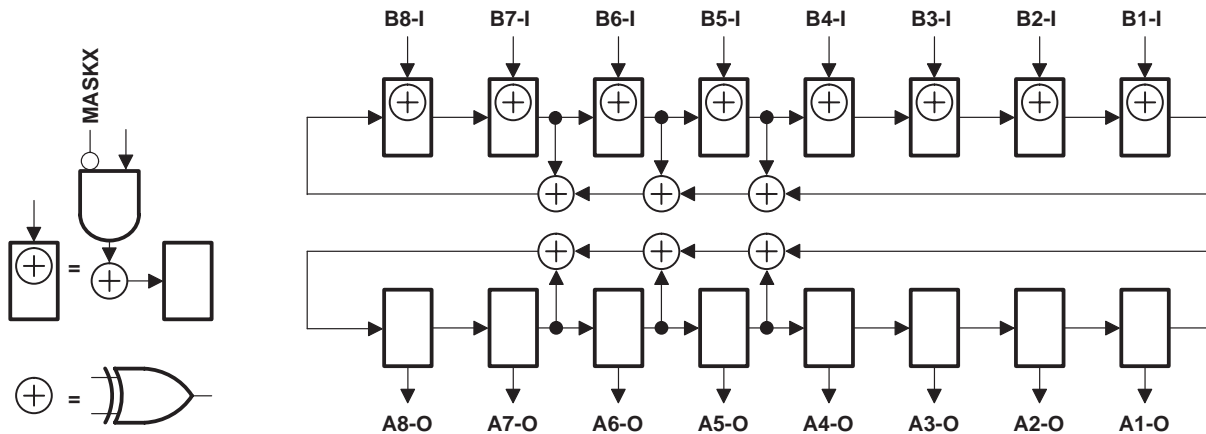

**Figure 10. 8-Bit PSA/PRPG Configuration (OEA = 1, OEB = 0)**

# SN54ABT8646, SN74ABT8646 SCAN TEST DEVICES WITH OCTAL BUS TRANSCEIVERS AND REGISTERS

SCBS123F – AUGUST 1992 – REVISED APRIL 2004

## simultaneous PSA and binary count up (PSA/COUNT)

Data appearing at the selected device input pins is compressed into an 8-bit parallel signature in the shift-register elements of the selected input BSCs on each rising edge of TCK. This data is updated in the shadow latches of the selected input BSCs and applied to the inputs of the normal on-chip logic. At the same time, an 8-bit binary count-up pattern is generated in the shift-register elements of the selected output BSCs on each rising edge of TCK, updated in the shadow latches, and applied to the associated device output pins on each falling edge of TCK. In addition, the shift-register elements of the opposite output BSCs count carries out of the selected output BSCs, extending the count to 16 bits. Figures 11 and 12 show the 8-bit linear-feedback shift-register algorithms through which the signature is generated. An initial seed value should be scanned into the BSR before performing this operation.

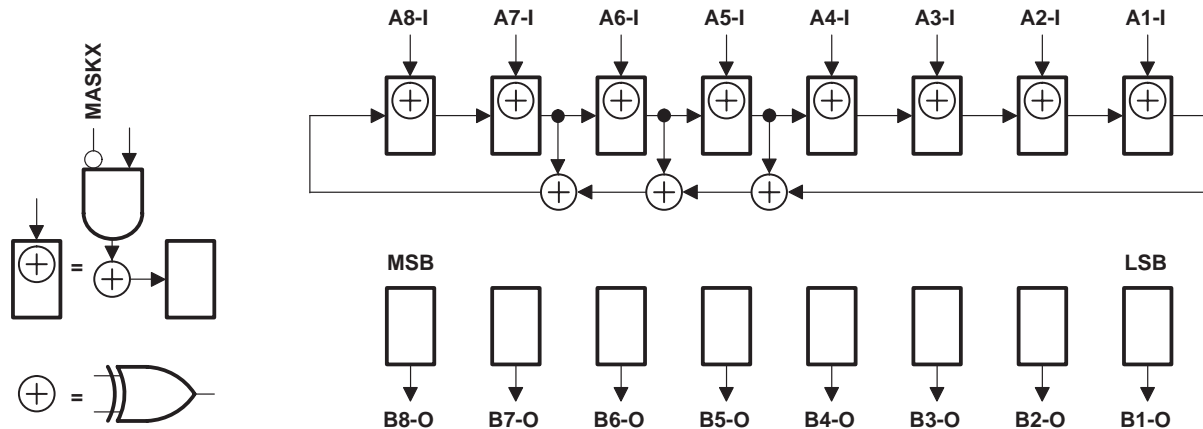

Figure 11. 8-Bit PSA/COUNT Configuration (OEA = 0, OEB = 1)

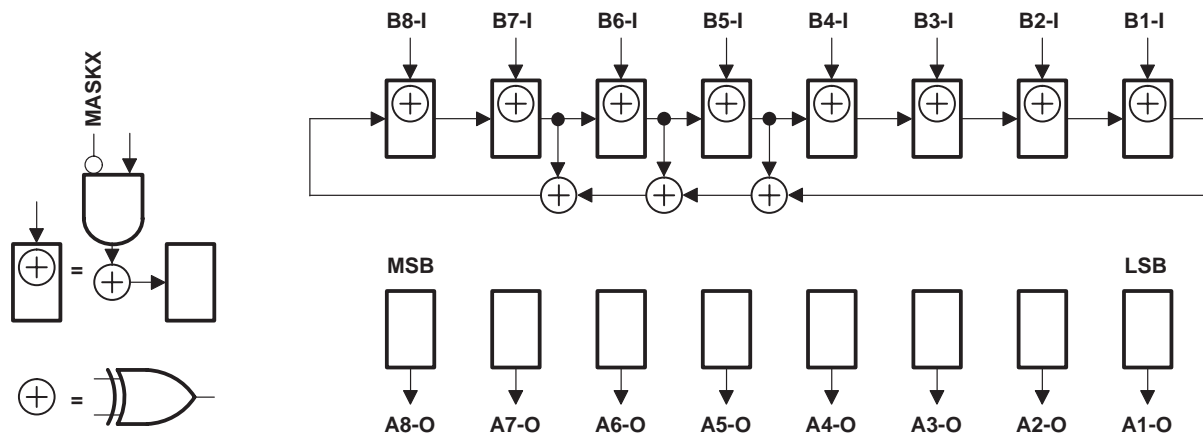

Figure 12. 8-Bit PSA/COUNT Configuration (OEA = 1, OEB = 0)

**timing description**

All test operations of the 'ABT8646 are synchronous to TCK. Data on the TDI, TMS, and normal-function inputs is captured on the rising edge of TCK. Data appears on the TDO and normal-function output pins on the falling edge of TCK. The TAP controller is advanced through its states (as shown in Figure 2) by changing the value of TMS on the falling edge of TCK and then applying a rising edge to TCK.

A simple timing example is shown in Figure 13. In this example, the TAP controller begins in the Test-Logic-Reset state and is advanced through its states as necessary to perform one instruction-register scan and one data-register scan. While in the Shift-IR and Shift-DR states, TDI is used to input serial data, and TDO is used to output serial data. The TAP controller then is returned to the Test-Logic-Reset state. Table 5 details the operation of the test circuitry during each TCK cycle.

**Table 5. Explanation of Timing Example**

TCK CYCLE(S)	TAP STATE AFTER TCK	DESCRIPTION
1	Test-Logic-Reset	TMS is changed to a logic 0 value on the falling edge of TCK to begin advancing the TAP controller toward the desired state.
2	Run-Test/Idle	
3	Select-DR-Scan	
4	Select-IR-Scan	
5	Capture-IR	The IR captures the 8-bit binary value 10000001 on the rising edge of TCK as the TAP controller exits the Capture-IR state.
6	Shift-IR	TDO becomes active and TDI is made valid on the falling edge of TCK. The first bit is shifted into the TAP on the rising edge of TCK as the TAP controller advances to the next state.
7–13	Shift-IR	One bit is shifted into the IR on each TCK rising edge. With TDI held at a logic 1 value, the 8-bit binary value 11111111 is serially scanned into the IR. At the same time, the 8-bit binary value 10000001 is serially scanned out of the IR via TDO. In TCK cycle 13, TMS is changed to a logic 1 value to end the IR scan on the next TCK cycle. The last bit of the instruction is shifted as the TAP controller advances from Shift-IR to Exit1-IR.
14	Exit1-IR	TDO becomes inactive (goes to the high-impedance state) on the falling edge of TCK.
15	Update-IR	The IR is updated with the new instruction (BYPASS) on the falling edge of TCK.
16	Select-DR-Scan	
17	Capture-DR	The bypass register captures a logic 0 value on the rising edge of TCK as the TAP controller exits the Capture-DR state.
18	Shift-DR	TDO becomes active and TDI is made valid on the falling edge of TCK. The first bit is shifted into the TAP on the rising edge of TCK as the TAP controller advances to the next state.
19–20	Shift-DR	The binary value 101 is shifted in via TDI, while the binary value 010 is shifted out via TDO.
21	Exit1-DR	TDO becomes inactive (goes to the high-impedance state) on the falling edge of TCK.
22	Update-DR	In general, the selected data register is updated with the new data on the falling edge of TCK.
23	Select-DR-Scan	
24	Select-IR-Scan	
25	Test-Logic-Reset	Test operation completed

# SN54ABT8646, SN74ABT8646 SCAN TEST DEVICES WITH OCTAL BUS TRANSCEIVERS AND REGISTERS

SCBS123F – AUGUST 1992 – REVISED APRIL 2004

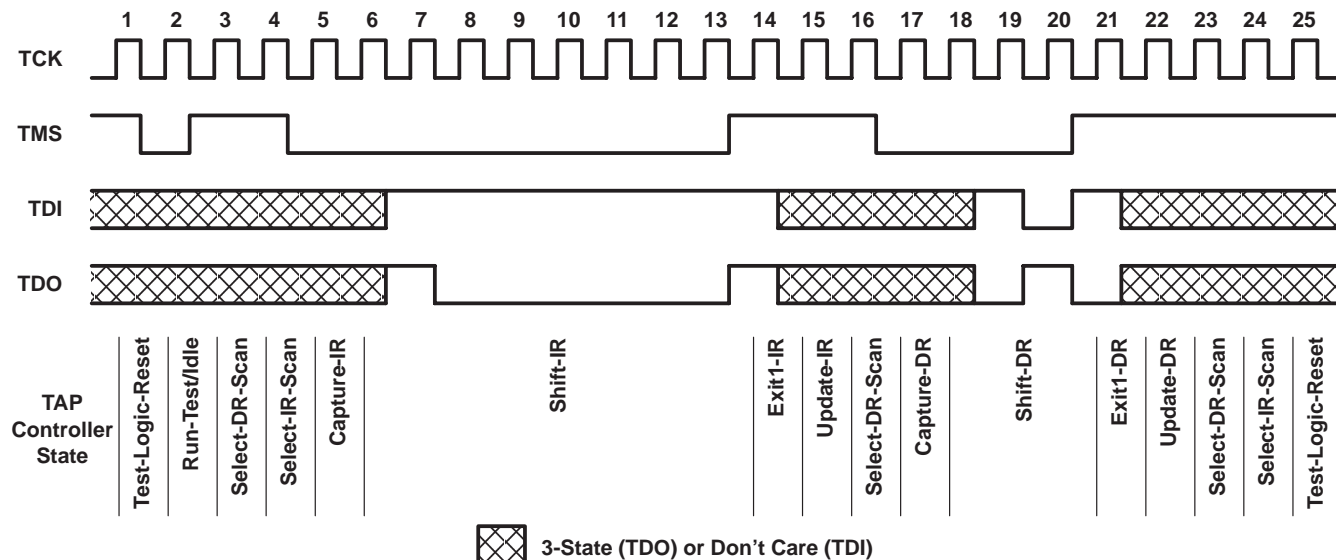

Figure 13. Timing Example

## absolute maximum ratings over operating free-air temperature range (unless otherwise noted)†

Supply voltage range, $V_{CC}$ .....	-0.5 V to 7 V
Input voltage range, $V_I$ (except I/O ports) (see Note 1) .....	-0.5 V to 7 V
Input voltage range, $V_I$ (I/O ports) (see Note 1) .....	-0.5 V to 5.5 V
Voltage range applied to any output in the high state or power-off state, $V_O$ .....	-0.5 V to 5.5 V
Current into any output in the low state, $I_O$ : SN54ABT8646 .....	96 mA
SN74ABT8646 .....	128 mA
Input clamp current, $I_{IK}$ ( $V_I < 0$ ) .....	-18 mA
Output clamp current, $I_{OK}$ ( $V_O < 0$ ) .....	-50 mA
Maximum power dissipation at $T_A = 55^\circ\text{C}$ (in still air) (see Note 2): DL package .....	0.7 W
DW package .....	1.7 W
Storage temperature range, $T_{stg}$ .....	-65°C to 150°C

† Stresses beyond those listed under "absolute maximum ratings" may cause permanent damage to the device. These are stress ratings only, and functional operation of the device at these or any other conditions beyond those indicated under "recommended operating conditions" is not implied. Exposure to absolute-maximum-rated conditions for extended periods may affect device reliability.

- NOTES: 1. The input and output negative-voltage ratings can be exceeded if the input and output clamp-current ratings are observed.  
2. The maximum package power dissipation is calculated using a junction temperature of 150°C and a board trace length of 750 mils. For more information, refer to the *Package Thermal Considerations* application note in the *ABT Advanced BiCMOS Technology Data Book*, literature number SCBD002.

**SN54ABT8646, SN74ABT8646**  
**SCAN TEST DEVICES WITH**  
**OCTAL BUS TRANSCEIVERS AND REGISTERS**  
SCBS123F – AUGUST 1992 – REVISED APRIL 2004

**recommended operating conditions (see Note 3)**

	SN54ABT8646		SN74ABT8646		UNIT
	MIN	MAX	MIN	MAX	
V <sub>CC</sub> Supply voltage	4.5	5.5	4.5	5.5	V
V <sub>IH</sub> High-level input voltage	2		2		V
V <sub>IL</sub> Low-level input voltage		0.8		0.8	V
V <sub>I</sub> Input voltage	0	V <sub>CC</sub>	0	V <sub>CC</sub>	V
I <sub>OH</sub> High-level output current		-24		-32	mA
I <sub>OL</sub> Low-level output current		48		64	mA
Δt/Δv Input transition rise or fall rate		10		10	ns/V
T <sub>A</sub> Operating free-air temperature	-55	125	-40	85	°C

NOTE 3: Unused pins (input or I/O) must be held high or low to prevent them from floating.

# SN54ABT8646, SN74ABT8646 SCAN TEST DEVICES WITH OCTAL BUS TRANSCEIVERS AND REGISTERS

SCBS123F – AUGUST 1992 – REVISED APRIL 2004

electrical characteristics over recommended operating free-air temperature range (unless otherwise noted)

PARAMETER	TEST CONDITIONS	T <sub>A</sub> = 25°C			SN54ABT8646		SN74ABT8646		UNIT			
		MIN	TYP†	MAX	MIN	MAX	MIN	MAX				
V <sub>IK</sub>	V <sub>CC</sub> = 4.5 V, I <sub>I</sub> = -18 mA			-1.2		-1.2		-1.2	V			
V <sub>OH</sub>	V <sub>CC</sub> = 4.5 V, I <sub>OH</sub> = -3 mA			2.5		2.5		2.5	V			
	V <sub>CC</sub> = 5 V, I <sub>OH</sub> = -3 mA			3		3		3				
	V <sub>CC</sub> = 4.5 V	I <sub>OH</sub> = -24 mA			2		2					
I <sub>OH</sub> = -32 mA				2*				2				
V <sub>OL</sub>	V <sub>CC</sub> = 4.5 V	I <sub>OL</sub> = 48 mA				0.55		0.55	V			
		I <sub>OL</sub> = 64 mA				0.55*		0.55				
I <sub>I</sub>	CLK, DIR, OE, S, TCK	V <sub>CC</sub> = 5.5 V, V <sub>I</sub> = V <sub>CC</sub> or GND					±1	±1	±1	μA		
	A or B ports						±100	±100	±100			
I <sub>IH</sub>	TDI, TMS	V <sub>CC</sub> = 5.5 V, V <sub>I</sub> = V <sub>CC</sub>				10		10	10	μA		
I <sub>IL</sub>	TDI, TMS	V <sub>CC</sub> = 5.5 V, V <sub>I</sub> = GND			-40	-160		-40	-160	μA		
I <sub>OZH</sub> ‡		V <sub>CC</sub> = 5.5 V, V <sub>O</sub> = 2.7 V				50		50	50	μA		
I <sub>OZL</sub> ‡		V <sub>CC</sub> = 5.5 V, V <sub>O</sub> = 0.5 V				-50		-50	-50	μA		
I <sub>off</sub>		V <sub>CC</sub> = 0, V <sub>I</sub> or V <sub>O</sub> ≤ 4.5 V				±100		±100	±100	μA		
I <sub>OZPU</sub>		V <sub>CC</sub> = 0 to 2 V, V <sub>O</sub> = 0.5 V or 2.7 V				±50		±50	±50	μA		
I <sub>OZPD</sub>		V <sub>CC</sub> = 2 V to 0, V <sub>O</sub> = 0.5 V or 2.7 V				±50		±50	±50	μA		
I <sub>CEX</sub>	Outputs high	V <sub>CC</sub> = 5.5 V, V <sub>O</sub> = 5.5 V				50		50	50	μA		
I <sub>O</sub> §		V <sub>CC</sub> = 5.5 V, V <sub>O</sub> = 2.5 V			-50	-100	-180	-50	-180	-50	-180	mA
I <sub>CC</sub>	A or B ports	V <sub>CC</sub> = 5.5 V, I <sub>O</sub> = 0, V <sub>I</sub> = V <sub>CC</sub> or GND	Outputs high			0.9	2		2	2	mA	
			Outputs low			30	38		38	38		
			Outputs disabled			0.9	2		2	2		
ΔI <sub>CC</sub> ¶		V <sub>CC</sub> = 5.5 V, One input at 3.4 V, Other inputs at V <sub>CC</sub> or GND				1.5		1.5	1.5	mA		
C <sub>I</sub>	Control inputs	V <sub>I</sub> = 2.5 V or 0.5 V				3				pF		
C <sub>io</sub>	A or B ports	V <sub>O</sub> = 2.5 V or 0.5 V				10				pF		
C <sub>O</sub>	TDO	V <sub>O</sub> = 2.5 V or 0.5 V				8				pF		

\* On products compliant to MIL-PRF-38535, this parameter does not apply.

† All typical values are at V<sub>CC</sub> = 5 V.

‡ The parameters I<sub>OZH</sub> and I<sub>OZL</sub> include the input leakage current.

§ Not more than one output should be tested at a time, and the duration of the test should not exceed one second.

¶ This is the increase in supply current for each input that is at the specified TTL voltage level, rather than V<sub>CC</sub> or GND.



**SN54ABT8646, SN74ABT8646**  
**SCAN TEST DEVICES WITH**  
**OCTAL BUS TRANSCEIVERS AND REGISTERS**

SCBS123F – AUGUST 1992 – REVISED APRIL 2004

**timing requirements over recommended ranges of supply voltage and operating free-air temperature (unless otherwise noted) (normal mode) (see Figure 14)**

			SN54ABT8646		SN74ABT8646		UNIT
			MIN	MAX	MIN	MAX	
$f_{\text{clock}}$	Clock frequency	CLKAB or CLKBA	0	100	0	100	MHz
$t_w$	Pulse duration	CLKAB or CLKBA high or low	3		3		ns
$t_{\text{su}}$	Setup time	A before CLKAB $\uparrow$ or B before CLKBA $\uparrow$	4.7		4.5		ns
$t_h$	Hold time	A after CLKAB $\uparrow$ or B after CLKBA $\uparrow$	0		0		ns

**timing requirements over recommended ranges of supply voltage and operating free-air temperature (unless otherwise noted) (test mode) (see Figure 14)**

			SN54ABT8646		SN74ABT8646		UNIT
			MIN	MAX	MIN	MAX	
$f_{\text{clock}}$	Clock frequency	TCK	0	50	0	50	MHz
$t_w$	Pulse duration	TCK high or low	5		5		ns
$t_{\text{su}}$	Setup time	A, B, CLK, DIR, $\overline{\text{OE}}$ , or S before TCK $\uparrow$	7		5		ns
		TDI before TCK $\uparrow$	6		6		
		TMS before TCK $\uparrow$	6		6		
$t_h$	Hold time	A, B, CLK, DIR, $\overline{\text{OE}}$ , or S after TCK $\uparrow$	0		0		ns
		TDI after TCK $\uparrow$	0		0		
		TMS after TCK $\uparrow$	0		0		
$t_d$	Delay time	Power up to TCK $\uparrow$	50*		50		ns
$t_r$	Rise time	V <sub>CC</sub> power up	1*		1		$\mu$ s

\* On products compliant to MIL-PRF-38535, this parameter is not production tested.



**SN54ABT8646, SN74ABT8646**  
**SCAN TEST DEVICES WITH**  
**OCTAL BUS TRANSCEIVERS AND REGISTERS**

SCBS123F – AUGUST 1992 – REVISED APRIL 2004

switching characteristics over recommended ranges of supply voltage and operating free-air temperature (unless otherwise noted) (normal mode) (see Figure 14)

PARAMETER	FROM (INPUT)	TO (OUTPUT)	SN54ABT8646					UNIT
			V <sub>CC</sub> = 5 V, T <sub>A</sub> = 25°C			MIN	MAX	
			MIN	TYP	MAX			
f <sub>max</sub>	CLKAB or CLKBA		100	130		100	MHz	
t <sub>PLH</sub>	A or B	B or A	2	3.7	4.5	2	5.5	ns
t <sub>PHL</sub>			2	3.5	4.6	2	5.8	
t <sub>PLH</sub>	CLKAB or CLKBA	B or A	3	4.4	5.3	3	6.3	ns
t <sub>PHL</sub>			2.5	4.3	5.2	2.5	6.7	
t <sub>PLH</sub>	SAB or SBA	B or A	2	4.8	6	2	7.5	ns
t <sub>PHL</sub>			2	4.7	5.9	2	7.8	
t <sub>PZH</sub>	DIR	B or A	2.5	4.4	5.4	2.5	6.6	ns
t <sub>PZL</sub>			3	4.8	6.2	3	8.1	
t <sub>PZH</sub>	$\overline{\text{OE}}$	B or A	2.5	4.4	5.4	2.5	6.7	ns
t <sub>PZL</sub>			3	5.2	6.2	3	7.6	
t <sub>PHZ</sub>	DIR	B or A	3	6	7.9	3	8.9	ns
t <sub>PLZ</sub>			3	5.2	6.6	3	8.1	
t <sub>PHZ</sub>	$\overline{\text{OE}}$	B or A	2	5.9	7.7	2.8	8.6	ns
t <sub>PLZ</sub>			3	5.2	6.2	3	8.3	

switching characteristics over recommended ranges of supply voltage and operating free-air temperature (unless otherwise noted) (normal mode) (see Figure 14)

PARAMETER	FROM (INPUT)	TO (OUTPUT)	SN74ABT8646					UNIT
			V <sub>CC</sub> = 5 V, T <sub>A</sub> = 25°C			MIN	MAX	
			MIN	TYP	MAX			
f <sub>max</sub>	CLKAB or CLKBA		100	130		100	MHz	
t <sub>PLH</sub>	A or B	B or A	2	3.7	4.5	2	5.2	ns
t <sub>PHL</sub>			2	3.5	4.4	2	5.5	
t <sub>PLH</sub>	CLKAB or CLKBA	B or A	3	4.4	5.3	3	6	ns
t <sub>PHL</sub>			2.5	4.3	5.2	2.5	6.2	
t <sub>PLH</sub>	SAB or SBA	B or A	2	4.8	6	2	7.3	ns
t <sub>PHL</sub>			2	4.7	5.9	2	7.4	
t <sub>PZH</sub>	DIR	B or A	2.5	4.4	5.3	2.5	6.5	ns
t <sub>PZL</sub>			3	4.8	6.2	3	7.1	
t <sub>PZH</sub>	$\overline{\text{OE}}$	B or A	2.5	4.4	5.4	2.5	6.5	ns
t <sub>PZL</sub>			3	5.2	6.2	3	7.5	
t <sub>PHZ</sub>	DIR	B or A	3	6	7	3	8.6	ns
t <sub>PLZ</sub>			3	5.2	6.2	3	7.9	
t <sub>PHZ</sub>	$\overline{\text{OE}}$	B or A	3	5.9	6.9	3	7.9	ns
t <sub>PLZ</sub>			3	5.2	6.2	3	7.4	



**SN54ABT8646, SN74ABT8646**  
**SCAN TEST DEVICES WITH**  
**OCTAL BUS TRANSCEIVERS AND REGISTERS**

SCBS123F – AUGUST 1992 – REVISED APRIL 2004

switching characteristics over recommended ranges of supply voltage and operating free-air temperature (unless otherwise noted) (test mode) (see Figure 14)

PARAMETER	FROM (INPUT)	TO (OUTPUT)	SN54ABT8646				UNIT	
			V <sub>CC</sub> = 5 V, T <sub>A</sub> = 25°C			MIN		MAX
			MIN	TYP	MAX			
f <sub>max</sub>	TCK		50	90		50	MHz	
t <sub>PLH</sub>	TCK↓	A or B	3.5	8	9.5	3.5	13.4	ns
t <sub>PHL</sub>			3	7.7	10	3	12	
t <sub>PLH</sub>	TCK↓	TDO	2.5	4.3	5.5	2.5	7	ns
t <sub>PHL</sub>			2.5	4.2	5.5	2.5	7	
t <sub>PZH</sub>	TCK↓	A or B	4.5	8.2	9.7	4.5	12.5	ns
t <sub>PZL</sub>			4.5	9	11.2	4.5	13.5	
t <sub>PZH</sub>	TCK↓	TDO	2.5	4.3	5.5	2.5	7	ns
t <sub>PZL</sub>			2.5	4.9	6	2.5	7.5	
t <sub>PHZ</sub>	TCK↓	A or B	3.5	8.4	13	3.5	14.5	ns
t <sub>PLZ</sub>			3	8	10.5	3	13.5	
t <sub>PHZ</sub>	TCK↓	TDO	3	5.9	7	3	9	ns
t <sub>PLZ</sub>			3	5	6.5	3	8	

switching characteristics over recommended ranges of supply voltage and operating free-air temperature (unless otherwise noted) (test mode) (see Figure 14)

PARAMETER	FROM (INPUT)	TO (OUTPUT)	SN74ABT8646				UNIT	
			V <sub>CC</sub> = 5 V, T <sub>A</sub> = 25°C			MIN		MAX
			MIN	TYP	MAX			
f <sub>max</sub>	TCK		50	90		50	MHz	
t <sub>PLH</sub>	TCK↓	A or B	3.5	8	9.5	3.5	12	ns
t <sub>PHL</sub>			3	7.7	9	3	11.5	
t <sub>PLH</sub>	TCK↓	TDO	2.5	4.3	5.5	2.5	6.5	ns
t <sub>PHL</sub>			2.5	4.2	5.5	2.5	6.5	
t <sub>PZH</sub>	TCK↓	A or B	4.5	8.2	9.5	4.5	12	ns
t <sub>PZL</sub>			4.5	9	10.5	4.5	13	
t <sub>PZH</sub>	TCK↓	TDO	2.5	4.3	5.5	2.5	6.5	ns
t <sub>PZL</sub>			2.5	4.9	6	2.5	7	
t <sub>PHZ</sub>	TCK↓	A or B	3.5	8.4	10.5	3.5	13.5	ns
t <sub>PLZ</sub>			3	8	10.5	3	13	
t <sub>PHZ</sub>	TCK↓	TDO	3	5.9	7	3	8.5	ns
t <sub>PLZ</sub>			3	5	6.5	3	7.5	



**SN54ABT8646, SN74ABT8646**  
**SCAN TEST DEVICES WITH**  
**OCTAL BUS TRANSCEIVERS AND REGISTERS**

SCBS123F – AUGUST 1992 – REVISED APRIL 2004

**PARAMETER MEASUREMENT INFORMATION**

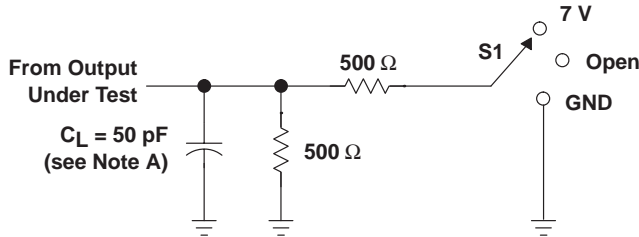

**LOAD CIRCUIT**

TEST	S1
$t_{PLH}/t_{PHL}$	Open
$t_{PLZ}/t_{PZL}$	7 V
$t_{PHZ}/t_{PZH}$	Open



**VOLTAGE WAVEFORMS**  
**PULSE DURATION**

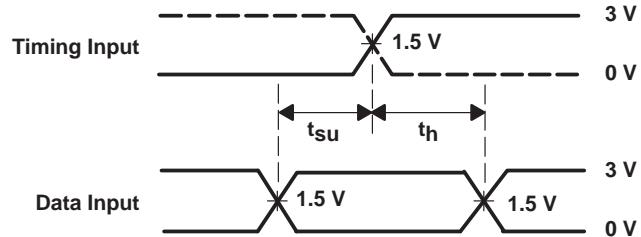

**VOLTAGE WAVEFORMS**  
**SETUP AND HOLD TIMES**

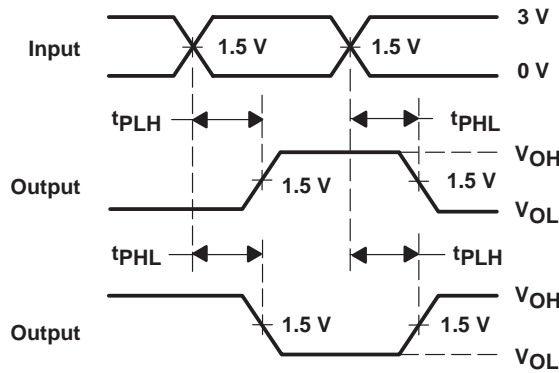

**VOLTAGE WAVEFORMS**  
**PROPAGATION DELAY TIMES**  
**INVERTING AND NONINVERTING OUTPUTS**

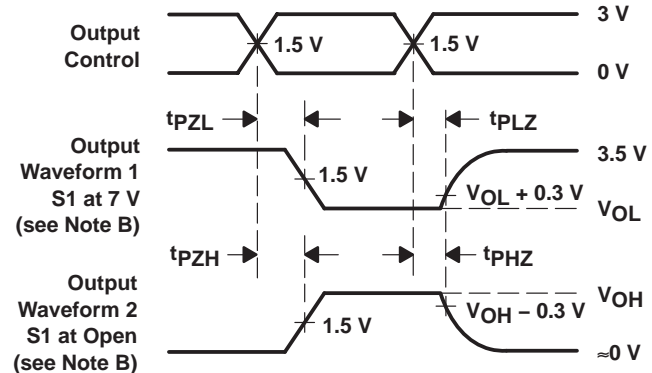

**VOLTAGE WAVEFORMS**  
**ENABLE AND DISABLE TIMES**  
**LOW- AND HIGH-LEVEL ENABLING**

- NOTES: A.  $C_L$  includes probe and jig capacitance.  
 B. Waveform 1 is for an output with internal conditions such that the output is low, except when disabled by the output control. Waveform 2 is for an output with internal conditions such that the output is high, except when disabled by the output control.  
 C. All input pulses are supplied by generators having the following characteristics:  $PRR \leq 10 \text{ MHz}$ ,  $Z_O = 50 \Omega$ ,  $t_r \leq 2.5 \text{ ns}$ ,  $t_f \leq 2.5 \text{ ns}$ .  
 D. The outputs are measured one at a time, with one transition per measurement.

**Figure 14. Load Circuit and Voltage Waveforms**

JT (R-GDIP-T\*\*)

CERAMIC DUAL-IN-LINE

24 LEADS SHOWN

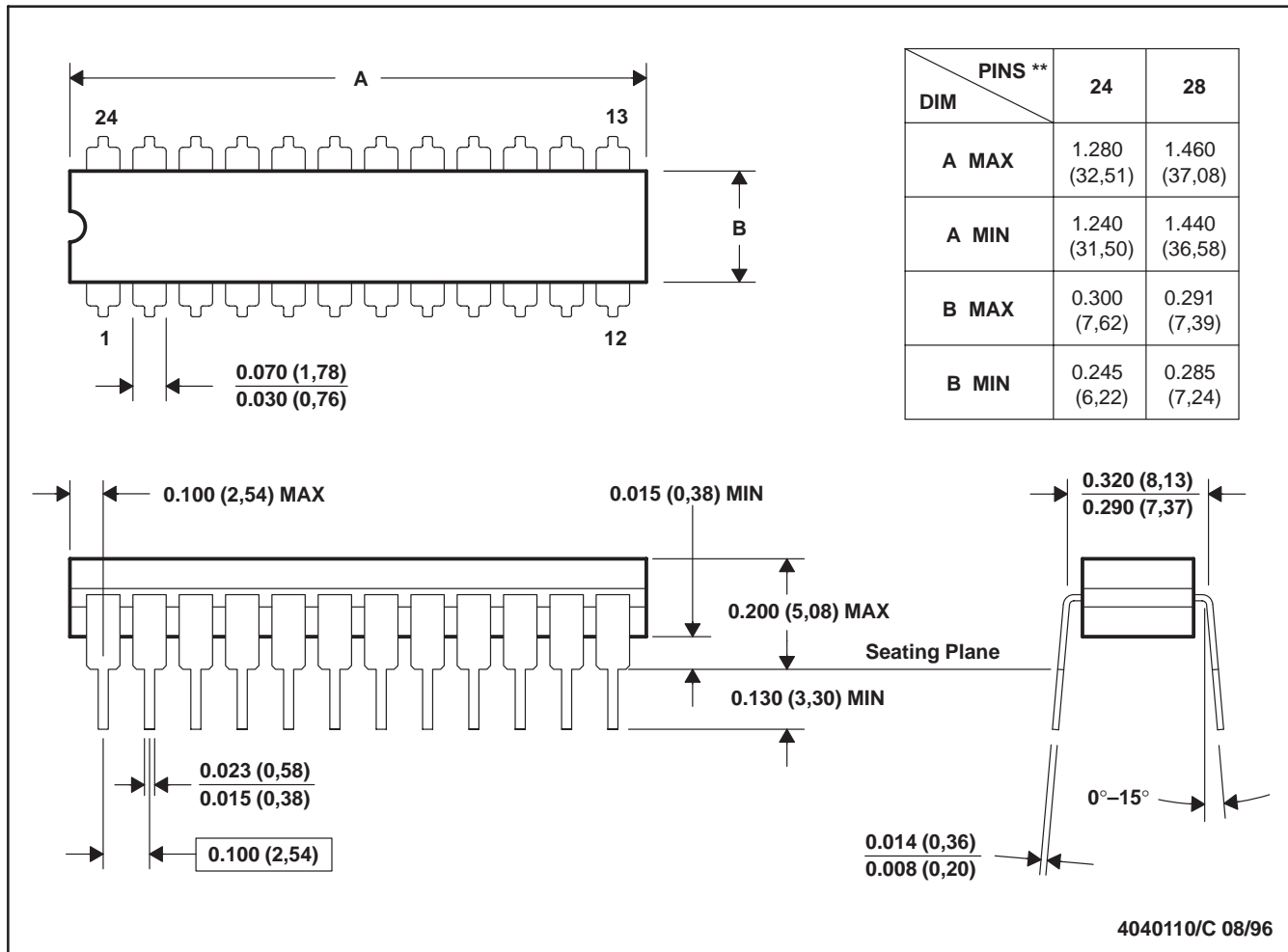

- NOTES: A. All linear dimensions are in inches (millimeters).  
 B. This drawing is subject to change without notice.  
 C. This package can be hermetically sealed with a ceramic lid using glass frit.  
 D. Index point is provided on cap for terminal identification.  
 E. Falls within MIL STD 1835 GDIP3-T24, GDIP4-T28, and JEDEC MO-058 AA, MO-058 AB

FK (S-CQCC-N\*\*)

LEADLESS CERAMIC CHIP CARRIER

28 TERMINAL SHOWN

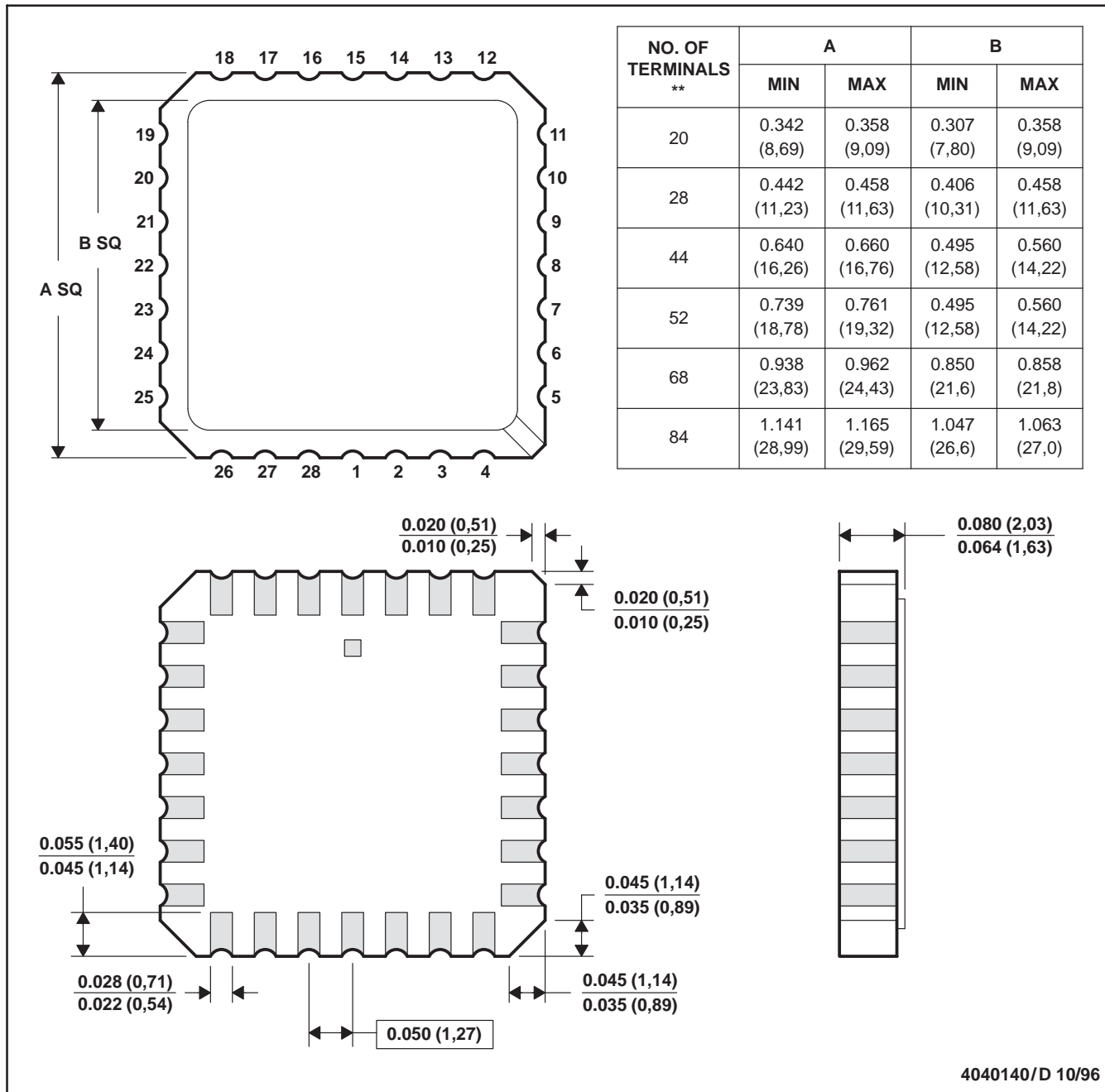

- NOTES:
- A. All linear dimensions are in inches (millimeters).
  - B. This drawing is subject to change without notice.
  - C. This package can be hermetically sealed with a metal lid.
  - D. The terminals are gold plated.
  - E. Falls within JEDEC MS-004

DW (R-PDSO-G28)

PLASTIC SMALL-OUTLINE PACKAGE

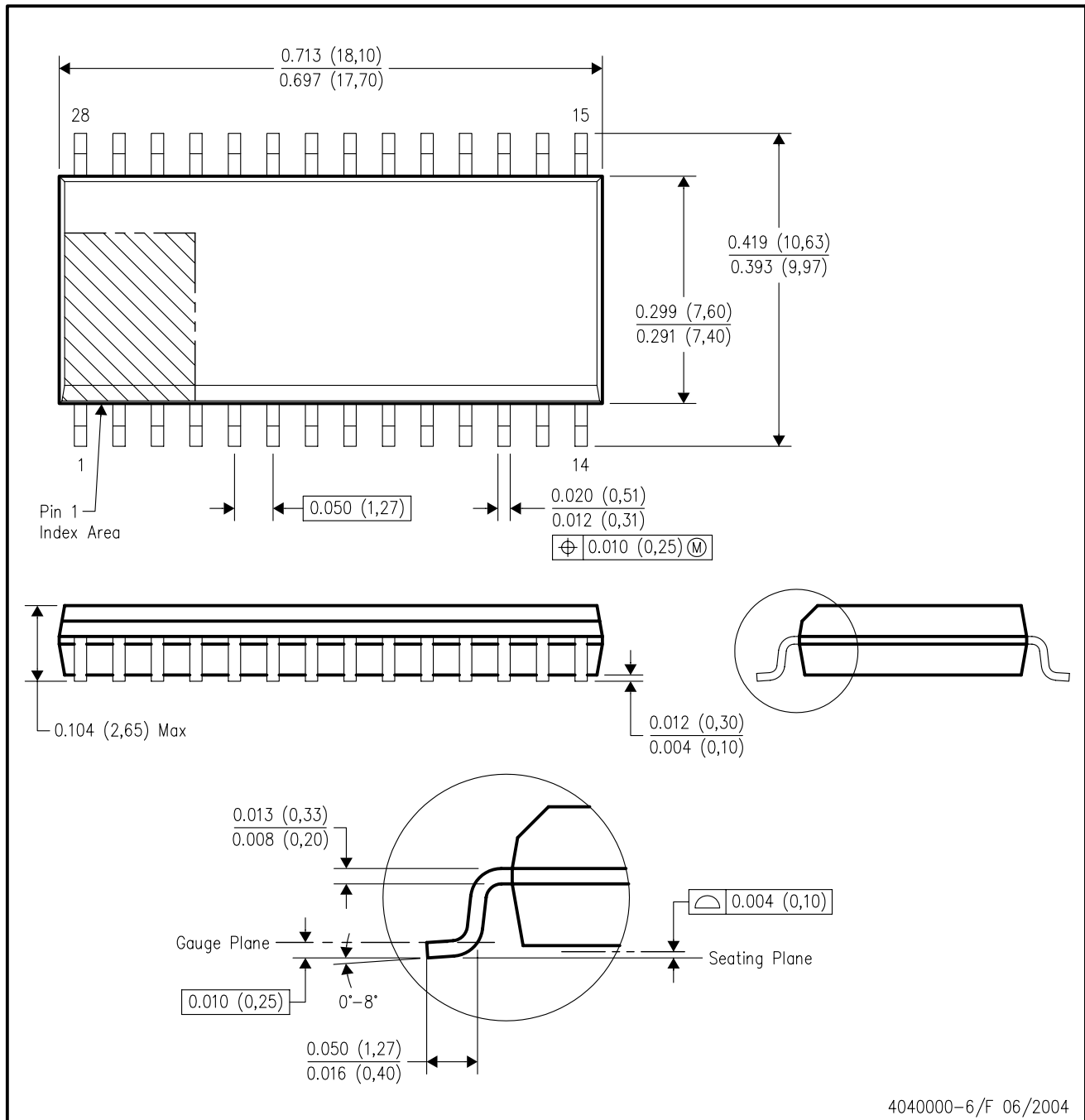

4040000-6/F 06/2004

- NOTES:
- A. All linear dimensions are in inches (millimeters).
  - B. This drawing is subject to change without notice.
  - C. Body dimensions do not include mold flash or protrusion not to exceed 0.006 (0,15).
  - D. Falls within JEDEC MS-013 variation AE.

DL (R-PDSO-G\*\*)

PLASTIC SMALL-OUTLINE PACKAGE

48 PINS SHOWN

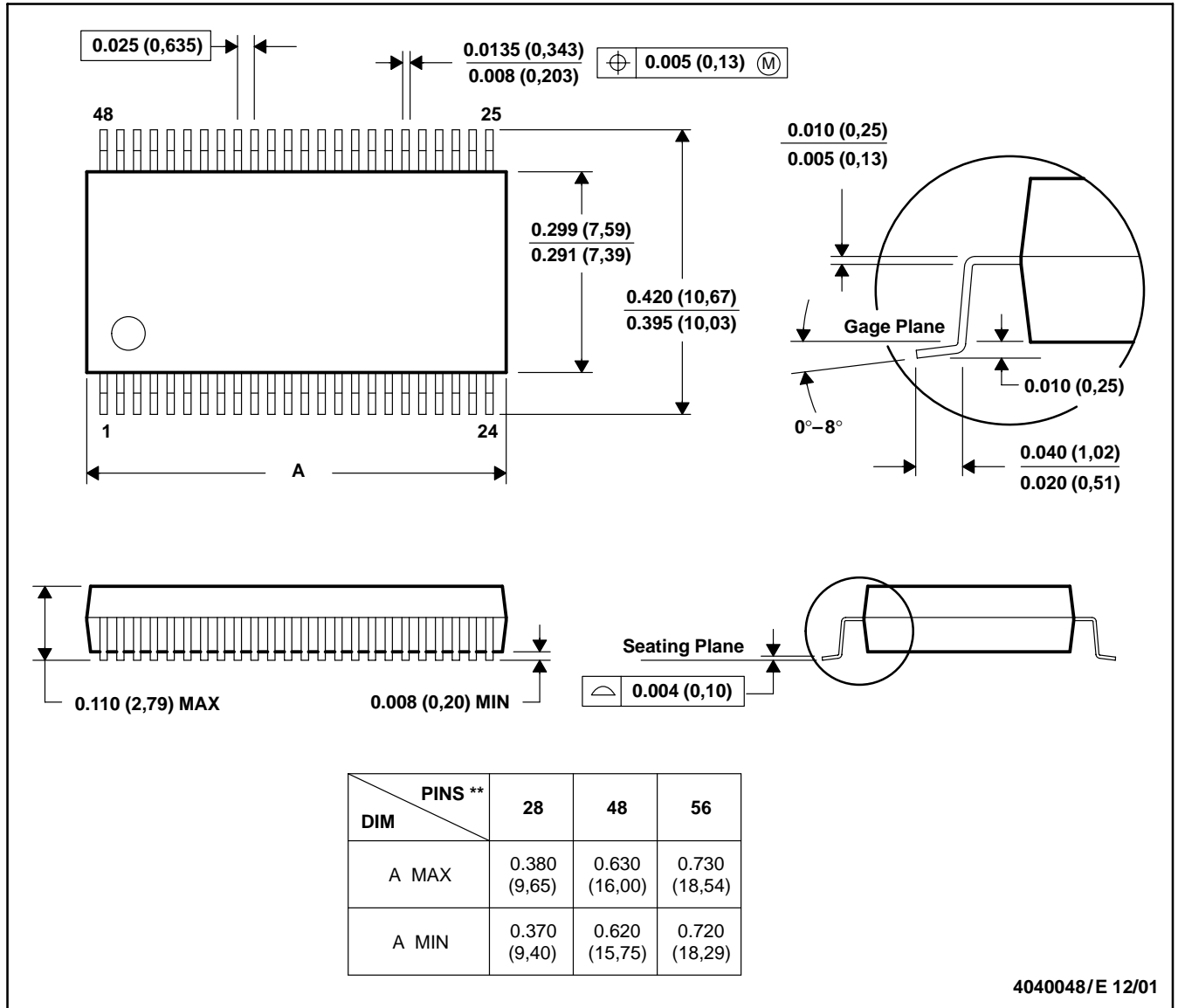

- NOTES: A. All linear dimensions are in inches (millimeters).  
 B. This drawing is subject to change without notice.  
 C. Body dimensions do not include mold flash or protrusion not to exceed 0.006 (0,15).  
 D. Falls within JEDEC MO-118

## IMPORTANT NOTICE

Texas Instruments Incorporated and its subsidiaries (TI) reserve the right to make corrections, modifications, enhancements, improvements, and other changes to its products and services at any time and to discontinue any product or service without notice. Customers should obtain the latest relevant information before placing orders and should verify that such information is current and complete. All products are sold subject to TI's terms and conditions of sale supplied at the time of order acknowledgment.

TI warrants performance of its hardware products to the specifications applicable at the time of sale in accordance with TI's standard warranty. Testing and other quality control techniques are used to the extent TI deems necessary to support this warranty. Except where mandated by government requirements, testing of all parameters of each product is not necessarily performed.

TI assumes no liability for applications assistance or customer product design. Customers are responsible for their products and applications using TI components. To minimize the risks associated with customer products and applications, customers should provide adequate design and operating safeguards.

TI does not warrant or represent that any license, either express or implied, is granted under any TI patent right, copyright, mask work right, or other TI intellectual property right relating to any combination, machine, or process in which TI products or services are used. Information published by TI regarding third-party products or services does not constitute a license from TI to use such products or services or a warranty or endorsement thereof. Use of such information may require a license from a third party under the patents or other intellectual property of the third party, or a license from TI under the patents or other intellectual property of TI.

Reproduction of information in TI data books or data sheets is permissible only if reproduction is without alteration and is accompanied by all associated warranties, conditions, limitations, and notices. Reproduction of this information with alteration is an unfair and deceptive business practice. TI is not responsible or liable for such altered documentation.

Resale of TI products or services with statements different from or beyond the parameters stated by TI for that product or service voids all express and any implied warranties for the associated TI product or service and is an unfair and deceptive business practice. TI is not responsible or liable for any such statements.

Following are URLs where you can obtain information on other Texas Instruments products and application solutions:

<b>Products</b>		<b>Applications</b>	
Amplifiers	<a href="http://amplifier.ti.com">amplifier.ti.com</a>	Audio	<a href="http://www.ti.com/audio">www.ti.com/audio</a>
Data Converters	<a href="http://dataconverter.ti.com">dataconverter.ti.com</a>	Automotive	<a href="http://www.ti.com/automotive">www.ti.com/automotive</a>
DSP	<a href="http://dsp.ti.com">dsp.ti.com</a>	Broadband	<a href="http://www.ti.com/broadband">www.ti.com/broadband</a>
Interface	<a href="http://interface.ti.com">interface.ti.com</a>	Digital Control	<a href="http://www.ti.com/digitalcontrol">www.ti.com/digitalcontrol</a>
Logic	<a href="http://logic.ti.com">logic.ti.com</a>	Military	<a href="http://www.ti.com/military">www.ti.com/military</a>
Power Mgmt	<a href="http://power.ti.com">power.ti.com</a>	Optical Networking	<a href="http://www.ti.com/opticalnetwork">www.ti.com/opticalnetwork</a>
Microcontrollers	<a href="http://microcontroller.ti.com">microcontroller.ti.com</a>	Security	<a href="http://www.ti.com/security">www.ti.com/security</a>
		Telephony	<a href="http://www.ti.com/telephony">www.ti.com/telephony</a>
		Video & Imaging	<a href="http://www.ti.com/video">www.ti.com/video</a>
		Wireless	<a href="http://www.ti.com/wireless">www.ti.com/wireless</a>

Mailing Address: Texas Instruments  
Post Office Box 655303 Dallas, Texas 75265