

# SN54ABT833, SN74ABT833 8-BIT TO 9-BIT PARITY BUS TRANSCEIVERS

SCBS195C – FEBRUARY 1991 – REVISED JANUARY 1997

- State-of-the-Art *EPIC-IIB™* BiCMOS Design Significantly Reduces Power Dissipation
- ESD Protection Exceeds 2000 V Per MIL-STD-883, Method 3015; Exceeds 200 V Using Machine Model (C = 200 pF, R = 0)
- Latch-Up Performance Exceeds 500 mA Per JEDEC Standard JESD-17
- Typical  $V_{OLP}$  (Output Ground Bounce) < 1 V at  $V_{CC} = 5$  V,  $T_A = 25^\circ\text{C}$
- High-Drive Outputs (–32-mA  $I_{OH}$ , 64-mA  $I_{OL}$ )
- Parity Error Flag With Parity Generator/Checker
- Register for Storage of the Parity Error Flag
- Package Options Include Plastic Small-Outline (DW) Packages, Ceramic Chip Carriers (FK), and Plastic (NT) and Ceramic (JT) DIPs

## description

The 'ABT833 8-bit to 9-bit parity transceivers are designed for communication between data buses. When data is transmitted from the A bus to the B bus, a parity bit is generated. When data is transmitted from the B bus to the A bus with its corresponding parity bit, the open-collector parity-error ( $\overline{ERR}$ ) output indicates whether or not an error in the B data has occurred. The output-enable ( $\overline{OEA}$  and  $\overline{OEB}$ ) inputs can be used to disable the device so that the buses are effectively isolated. The 'ABT833 provide true data at their outputs.

A 9-bit parity generator/checker generates a parity-odd (PARITY) output and monitors the parity of the I/O ports with the  $\overline{ERR}$  flag.  $\overline{ERR}$  is clocked into the register on the rising edge of the clock (CLK) input. The error flag register is cleared with a low pulse on the clear ( $\overline{CLR}$ ) input. When both  $\overline{OEA}$  and  $\overline{OEB}$  are low, data is transferred from the A bus to the B bus and inverted parity is generated. Inverted parity is a forced error condition that gives the designer more system diagnostic capability.

SN54ABT833 . . . JT PACKAGE  
SN74ABT833 . . . DW OR NT PACKAGE  
(TOP VIEW)

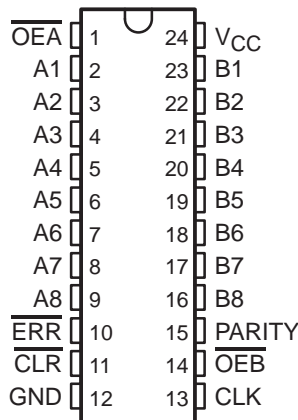

SN54ABT833 . . . FK PACKAGE  
(TOP VIEW)

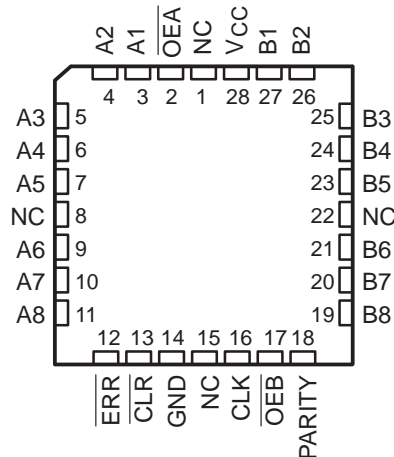

NC – No internal connection



Please be aware that an important notice concerning availability, standard warranty, and use in critical applications of Texas Instruments semiconductor products and disclaimers thereto appears at the end of this data sheet.

EPIC-IIB is a trademark of Texas Instruments Incorporated.

UNLESS OTHERWISE NOTED this document contains PRODUCTION DATA information current as of publication date. Products conform to specifications per the terms of Texas Instruments standard warranty. Production processing does not necessarily include testing of all parameters.

 **TEXAS  
INSTRUMENTS**

POST OFFICE BOX 655303 • DALLAS, TEXAS 75265

Copyright © 1997, Texas Instruments Incorporated

# SN54ABT833, SN74ABT833 8-BIT TO 9-BIT PARITY BUS TRANSCEIVERS

SCBS195C – FEBRUARY 1991 – REVISED JANUARY 1997

## description (continued)

To ensure the high-impedance state during power up or power down,  $\overline{OE}$  should be tied to  $V_{CC}$  through a pullup resistor; the minimum value of the resistor is determined by the current-sinking capability of the driver.

The SN54ABT833 is characterized for operation over the full military temperature range of  $-55^{\circ}\text{C}$  to  $125^{\circ}\text{C}$ . The SN74ABT833 is characterized for operation from  $-40^{\circ}\text{C}$  to  $85^{\circ}\text{C}$ .

FUNCTION TABLE

INPUTS						OUTPUT AND I/O				FUNCTION
$\overline{OEB}$	$\overline{OEA}$	$\overline{CLR}$	CLK	Ai Σ OF H's	Bi† Σ OF H's	A	B	PARITY	$\overline{ERR}‡$	
L	H	X	X	Odd Even	NA	NA	A	L H	NA	A data to B bus and generate parity
H	L	H	↑	NA	Odd Even	B	NA	NA	H L	B data to A bus and check parity
X	X	L	X	X	X	X	NA	NA	H	Check error-flag register
H	H	H	No↑	X	X	Z	Z	Z	NC	Isolation§
		L	No↑	H						
		H	↑	Odd					H	
		H	↑	Even					L	
L	L	X	X	Odd Even	NA	NA	A	H L	NA	A data to B bus and generate inverted parity

NA = not applicable, NC = no change, X = don't care

† Summation of high-level inputs includes PARITY along with Bi inputs.

‡ Output states shown assume ERR was previously high.

§ In this mode,  $\overline{ERR}$  (when clocked) shows inverted parity of the A bus.

## logic symbol¶

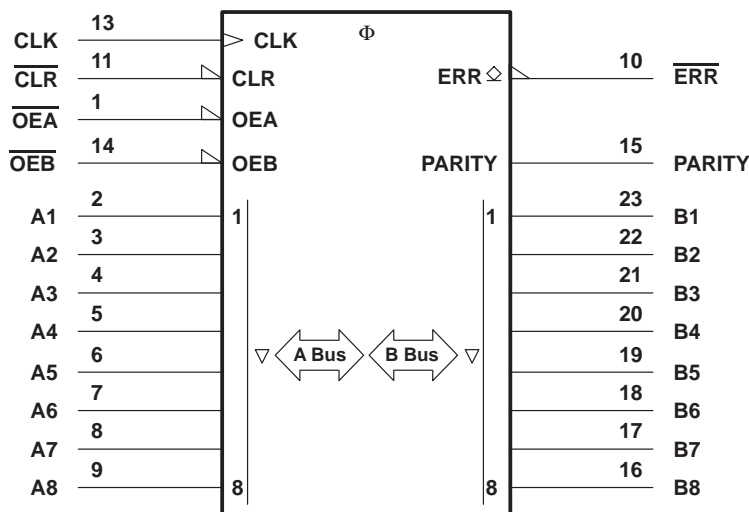

¶ This symbol is in accordance with ANSI/IEEE Std 91-1984 and IEC Publication 617-12.

Pin numbers shown are for the DW, JT, and NT packages.



POST OFFICE BOX 655303 • DALLAS, TEXAS 75265

logic diagram (positive logic)

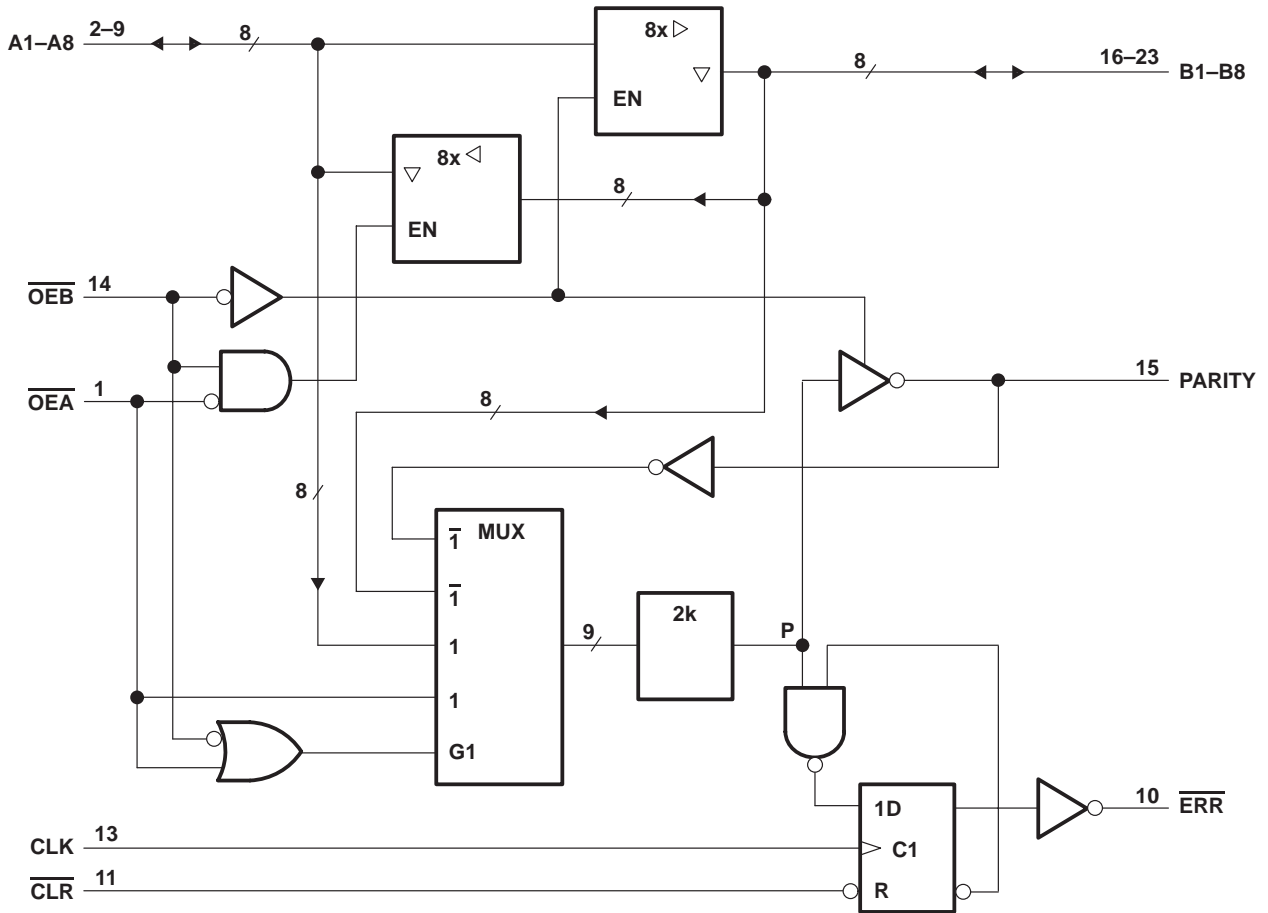

Pin numbers shown are for the DW, JT, and NT packages.

ERROR-FLAG FUNCTION TABLE

INPUTS		INTERNAL TO DEVICE	OUTPUT PRE-STATE	OUTPUT ERR	FUNCTION
CLR	CLK	POINT P	ERR <sub>n-1</sub> †		
H	↑	H	H	H	Sample
H	↑	X	L	L	
H	↑	L	X	L	
L	X	X	X	H	Clear

† The state of ERR before any changes at CLR, CLK, or point P

# SN54ABT833, SN74ABT833 8-BIT TO 9-BIT PARITY BUS TRANSCEIVERS

SCBS195C – FEBRUARY 1991 – REVISED JANUARY 1997

## error-flag waveforms

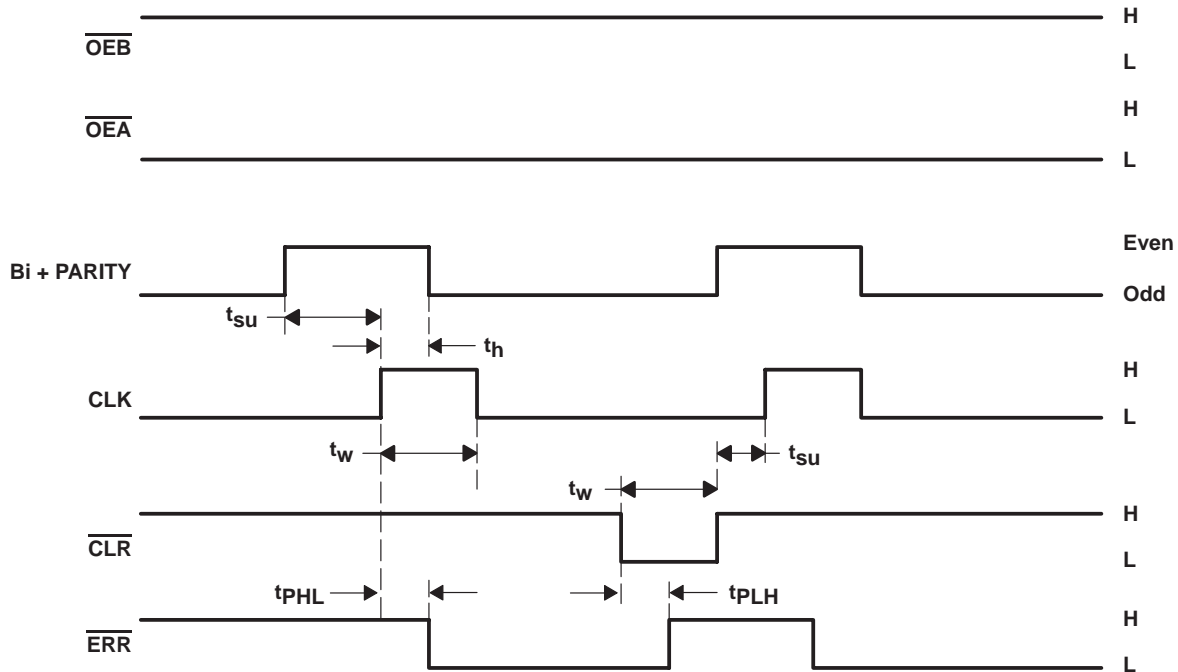

## absolute maximum ratings over operating free-air temperature range (unless otherwise noted)†

Supply voltage range, $V_{CC}$ .....	-0.5 V to 7 V
Input voltage range, $V_I$ (except I/O ports) (see Note 1) .....	-0.5 V to 7 V
Voltage range applied to any output in the high or power-off state, $V_O$ .....	-0.5 V to 5.5 V
Current into any output in the low state, $I_O$ : SN54ABT833 .....	96 mA
SN74ABT833 .....	128 mA
Input clamp current, $I_{IK}$ ( $V_I < 0$ ) .....	-18 mA
Output clamp current, $I_{OK}$ ( $V_O < 0$ ) .....	-50 mA
Package thermal impedance, $\theta_{JA}$ (see Note 2): DW package .....	81°C/W
NT package .....	67°C/W
Storage temperature range, $T_{stg}$ .....	-65°C to 150°C

† Stresses beyond those listed under "absolute maximum ratings" may cause permanent damage to the device. These are stress ratings only, and functional operation of the device at these or any other conditions beyond those indicated under "recommended operating conditions" is not implied. Exposure to absolute-maximum-rated conditions for extended periods may affect device reliability.

- NOTES: 1. The input and output negative-voltage ratings may be exceeded if the input and output clamp-current ratings are observed.  
2. The package thermal impedance is calculated in accordance with EIA/JEDEC Std JESD51, except for through-hole packages, which use a trace length of zero.



POST OFFICE BOX 655303 • DALLAS, TEXAS 75265

# SN54ABT833, SN74ABT833 8-BIT TO 9-BIT PARITY BUS TRANSCEIVERS

SCBS195C – FEBRUARY 1991 – REVISED JANUARY 1997

## recommended operating conditions (see Note 3)

		SN54ABT833		SN74ABT833		UNIT
		MIN	MAX	MIN	MAX	
V <sub>CC</sub>	Supply voltage	4.5	5.5	4.5	5.5	V
V <sub>IH</sub>	High-level input voltage	2		2		V
V <sub>IL</sub>	Low-level input voltage		0.8		0.8	V
V <sub>I</sub>	Input voltage	0	V <sub>CC</sub>	0	V <sub>CC</sub>	V
V <sub>OH</sub>	High-level output voltage		$\overline{\text{ERR}}$		5.5	V
I <sub>OH</sub>	High-level output current		Except $\overline{\text{ERR}}$		-24	mA
I <sub>OL</sub>	Low-level output current				48	mA
Δt/Δv	Input transition rise or fall rate		Outputs enabled		5	ns/V
T <sub>A</sub>	Operating free-air temperature	-55	125	-40	85	°C

NOTE 3: Unused pins (input or I/O) must be held high or low to prevent them from floating.

# SN54ABT833, SN74ABT833 8-BIT TO 9-BIT PARITY BUS TRANSCEIVERS

SCBS195C – FEBRUARY 1991 – REVISED JANUARY 1997

electrical characteristics over recommended operating free-air temperature range (unless otherwise noted)

PARAMETER	TEST CONDITIONS	T <sub>A</sub> = 25°C			SN54ABT833		SN74ABT833		UNIT		
		MIN	TYP†	MAX	MIN	MAX	MIN	MAX			
V <sub>IK</sub>	V <sub>CC</sub> = 4.5 V, I <sub>I</sub> = -18 mA			-1.2		-1.2		-1.2	V		
V <sub>OH</sub>	All outputs except ERR	V <sub>CC</sub> = 4.5 V, I <sub>OH</sub> = -3 mA		2.5		2.5		2.5	V		
		V <sub>CC</sub> = 5 V, I <sub>OH</sub> = -3 mA		3		3		3			
		V <sub>CC</sub> = 4.5 V	I <sub>OH</sub> = -24 mA		2		2			2	
V <sub>OL</sub>	V <sub>CC</sub> = 4.5 V	I <sub>OL</sub> = 24 mA				0.55			V		
		I <sub>OL</sub> = 64 mA				0.55*		0.55			
V <sub>hys</sub>				100					mV		
I <sub>OH</sub>	ERR	V <sub>CC</sub> = 4.5 V, V <sub>OH</sub> = 5.5 V		20		20		20	μA		
I <sub>I</sub>	Control inputs	V <sub>CC</sub> = 5.5 V, V <sub>I</sub> = V <sub>CC</sub> or GND		±1		±1		±1	μA		
	A or B ports			±100		±100		±100			
I <sub>IL</sub>	A or B ports	V <sub>CC</sub> = 0, V <sub>I</sub> = GND		-50		-50		-50	μA		
I <sub>OZH</sub> ‡		V <sub>CC</sub> = 5.5 V, V <sub>O</sub> = 2.7 V		50		50		50	μA		
I <sub>OZL</sub> ‡		V <sub>CC</sub> = 5.5 V, V <sub>O</sub> = 0.5 V		-50		-50		-50	μA		
I <sub>off</sub>		V <sub>CC</sub> = 0, V <sub>I</sub> or V <sub>O</sub> ≤ 4.5 V		±100				±100	μA		
I <sub>CEX</sub>		V <sub>CC</sub> = 5.5 V, V <sub>O</sub> = 5.5 V	Outputs high		50		50		μA		
I <sub>O</sub> §		V <sub>CC</sub> = 5.5 V, V <sub>O</sub> = 2.5 V		-50	-100	-200¶	-50	-200¶	-50	-200¶	mA
I <sub>CC</sub>	A or B ports	V <sub>CC</sub> = 5.5 V, I <sub>O</sub> = 0, V <sub>I</sub> = V <sub>CC</sub> or GND	Outputs high		1	250		250		250	μA
			Outputs low		24	38¶		38¶		38¶	mA
			Outputs disabled		0.5	250		250		250	μA
ΔI <sub>CC</sub> #	Data inputs	V <sub>CC</sub> = 5.5 V, One input at 3.4 V, Other inputs at V <sub>CC</sub> or GND	Outputs enabled		1.5		1.5		1.5	mA	
			Outputs disabled		50		50		50	μA	
	Control inputs	V <sub>CC</sub> = 5.5 V, One input at 3.4 V, Other inputs at V <sub>CC</sub> or GND		1.5		1.5		1.5	mA		
C <sub>i</sub>	Control inputs	V <sub>I</sub> = 2.5 V or 0.5 V		4.5					pF		
C <sub>io</sub>	A or B ports	V <sub>O</sub> = 2.5 V or 0.5 V		10.5					pF		

\* On products compliant to MIL-PRF-38535, this parameter does not apply.

† All typical values are at V<sub>CC</sub> = 5 V.

‡ The parameters I<sub>OZH</sub> and I<sub>OZL</sub> include the input leakage current.

§ Not more than one output should be tested at a time, and the duration of the test should not exceed one second.

¶ These limits may vary among suppliers.

# This is the increase in supply current for each input that is at the specified TTL voltage level rather than V<sub>CC</sub> or GND.

PRODUCT PREVIEW information concerns products in the formative or design phase of development. Characteristic data and other specifications are design goals. Texas Instruments reserves the right to change or discontinue these products without notice.



POST OFFICE BOX 655303 • DALLAS, TEXAS 75265

# SN54ABT833, SN74ABT833 8-BIT TO 9-BIT PARITY BUS TRANSCEIVERS

SCBS195C – FEBRUARY 1991 – REVISED JANUARY 1997

**timing requirements over recommended ranges of supply voltage and operating free-air temperature (unless otherwise noted) (see Figure 1)**

		$V_{CC} = 5\text{ V},$ $T_A = 25^\circ\text{C}$		SN54ABT833		SN74ABT833		UNIT
		MIN	MAX	MIN	MAX	MIN	MAX	
$t_w$	Pulse duration	CLK high or low	3	3	3	3	3	ns
		CLR low	3	3	3	3	3	
$t_{su}$	Setup time before CLK $\uparrow$	B or PARITY high	9.8	9.8	9.8	9.8	9.8	ns
		B or PARITY low	8.1	8.1	8.1	8.1	8.1	
		CLR	2	2	2	2	2	
$t_h$	Hold time after CLK $\uparrow$	B or PARITY	0	0	0	0	0	ns

**switching characteristics over recommended ranges of supply voltage and operating free-air temperature (unless otherwise noted) (see Figure 1)**

PARAMETER	FROM (INPUT)	TO (OUTPUT)	$V_{CC} = 5\text{ V},$ $T_A = 25^\circ\text{C}$			SN54ABT833		SN74ABT833		UNIT
			MIN	TYP $\dagger$	MAX	MIN	MAX	MIN	MAX	
$t_{PLH}$	A or B	B or A	1.2	2.8	4.8	1.2	5.4	1.2	5.3	ns
$t_{PHL}$			1	3	4.8 $\ddagger$	1	5.4	1	5.3 $\ddagger$	
$t_{PLH}$	A	PARITY	2.1	5.5	9.5	2.1	11.3	2.1	11.2	ns
$t_{PHL}$			2.5	5.3	9.7	2.5	11.1	2.5	11	
$t_{PZH}$	$\overline{OE}$	PARITY	2.6	6.2	8.5	2.6	10.6	2.6	10.5	ns
$t_{PZL}$			2.6 $\ddagger$	5.8	8.6	2.6 $\ddagger$	10.1	2.6 $\ddagger$	10	
$t_{PLH}$	$\overline{CLR}$	$\overline{ERR}$	1	3.2	4.8 $\ddagger$	1	5.3	1	5.2	ns
$t_{PHL}$	CLK		1.2 $\ddagger$	2.8	5.7	1.2 $\ddagger$	6.3	1.2 $\ddagger$	6.2	
$t_{PZH}$	$\overline{OE}$	A, B, or PARITY	1	3.7	5.8 $\ddagger$	1	6.6	1	6.5 $\ddagger$	ns
$t_{PZL}$			1.3 $\ddagger$	3.8	5.8	1.3 $\ddagger$	6.6	1.3 $\ddagger$	6.5 $\ddagger$	
$t_{PHZ}$	$\overline{OE}$	A, B, or PARITY	1.9 $\ddagger$	4.4	7.3	1.9 $\ddagger$	8	1.9 $\ddagger$	7.9	ns
$t_{PLZ}$			2.2 $\ddagger$	4.4	7.7	2.2 $\ddagger$	8.2	2.2 $\ddagger$	8.1	

$\dagger$  All typical values are at  $V_{CC} = 5\text{ V}$ .

$\ddagger$  These limits may vary among suppliers.

# SN54ABT833, SN74ABT833 8-BIT TO 9-BIT PARITY BUS TRANSCEIVERS

SCBS195C – FEBRUARY 1991 – REVISED JANUARY 1997

## PARAMETER MEASUREMENT INFORMATION

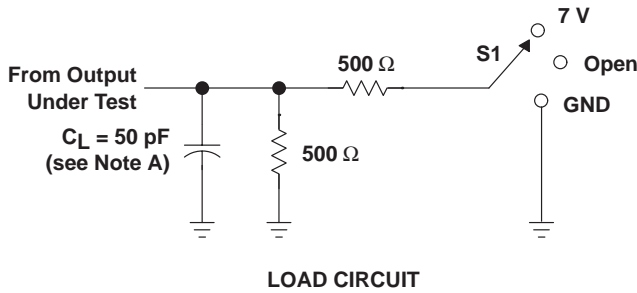

TEST	S1
$t_{PLH}/t_{PHL}$	Open
$t_{PLZ}/t_{PZL}$	7 V
$t_{PHZ}/t_{PZH}$	Open

ERR	S1
$t_{PHL}$	7 V
$t_{PLH}$	7 V

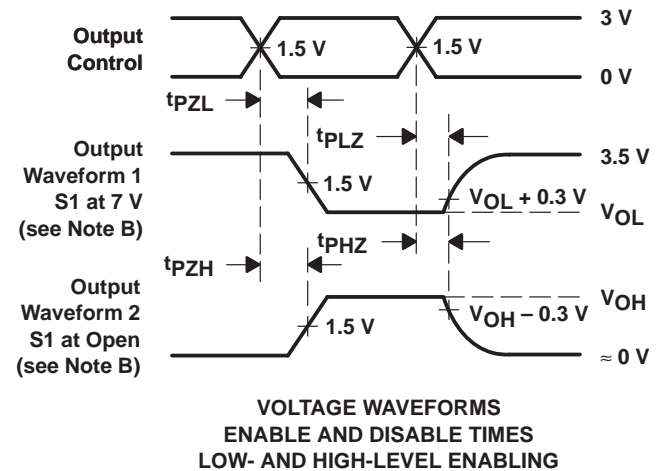
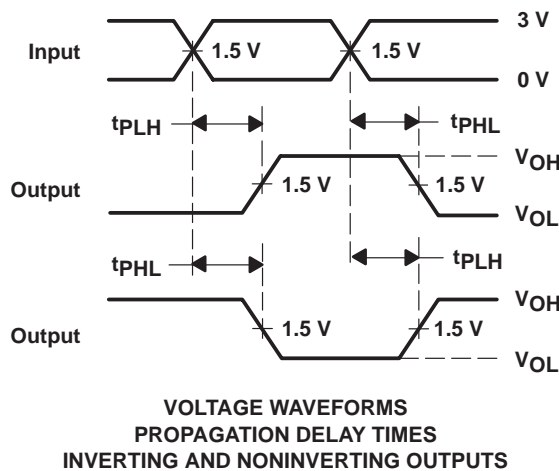
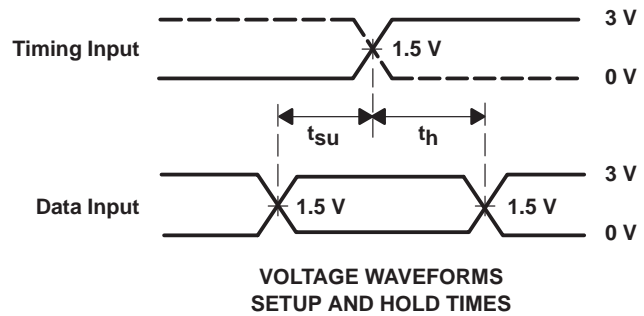
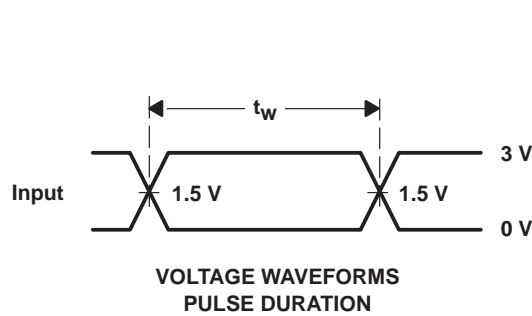

- NOTES: A.  $C_L$  includes probe and jig capacitance.  
 B. Waveform 1 is for an output with internal conditions such that the output is low except when disabled by the output control. Waveform 2 is for an output with internal conditions such that the output is high except when disabled by the output control.  
 C. All input pulses are supplied by generators having the following characteristics: PRR  $\leq 10 \text{ MHz}$ ,  $Z_O = 50 \Omega$ ,  $t_r \leq 2.5 \text{ ns}$ ,  $t_f \leq 2.5 \text{ ns}$   
 D. The outputs are measured one at a time with one transition per measurement.

Figure 1. Load Circuit and Voltage Waveforms

**PACKAGING INFORMATION**

Orderable Device	Status <sup>(1)</sup>	Package Type	Package Drawing	Pins	Package Qty	Eco Plan <sup>(2)</sup>	Lead/Ball Finish	MSL Peak Temp <sup>(3)</sup>
SN74ABT833DW	ACTIVE	SOIC	DW	24	25	Green (RoHS & no Sb/Br)	CU NIPDAU	Level-1-260C-UNLIM
SN74ABT833DWE4	ACTIVE	SOIC	DW	24	25	Green (RoHS & no Sb/Br)	CU NIPDAU	Level-1-260C-UNLIM
SN74ABT833DWR	ACTIVE	SOIC	DW	24	2000	Green (RoHS & no Sb/Br)	CU NIPDAU	Level-1-260C-UNLIM
SN74ABT833DWRE4	ACTIVE	SOIC	DW	24	2000	Green (RoHS & no Sb/Br)	CU NIPDAU	Level-1-260C-UNLIM
SN74ABT833NSR	ACTIVE	SO	NS	24	2000	Green (RoHS & no Sb/Br)	CU NIPDAU	Level-1-260C-UNLIM
SN74ABT833NSRE4	ACTIVE	SO	NS	24	2000	Green (RoHS & no Sb/Br)	CU NIPDAU	Level-1-260C-UNLIM
SN74ABT833NT	ACTIVE	PDIP	NT	24	15	Pb-Free (RoHS)	CU NIPDAU	N / A for Pkg Type
SN74ABT833NTE4	ACTIVE	PDIP	NT	24	15	Pb-Free (RoHS)	CU NIPDAU	N / A for Pkg Type

<sup>(1)</sup> The marketing status values are defined as follows:

**ACTIVE:** Product device recommended for new designs.

**LIFEBUY:** TI has announced that the device will be discontinued, and a lifetime-buy period is in effect.

**NRND:** Not recommended for new designs. Device is in production to support existing customers, but TI does not recommend using this part in a new design.

**PREVIEW:** Device has been announced but is not in production. Samples may or may not be available.

**OBSELETE:** TI has discontinued the production of the device.

<sup>(2)</sup> Eco Plan - The planned eco-friendly classification: Pb-Free (RoHS), Pb-Free (RoHS Exempt), or Green (RoHS & no Sb/Br) - please check <http://www.ti.com/productcontent> for the latest availability information and additional product content details.

**TBD:** The Pb-Free/Green conversion plan has not been defined.

**Pb-Free (RoHS):** TI's terms "Lead-Free" or "Pb-Free" mean semiconductor products that are compatible with the current RoHS requirements for all 6 substances, including the requirement that lead not exceed 0.1% by weight in homogeneous materials. Where designed to be soldered at high temperatures, TI Pb-Free products are suitable for use in specified lead-free processes.

**Pb-Free (RoHS Exempt):** This component has a RoHS exemption for either 1) lead-based flip-chip solder bumps used between the die and package, or 2) lead-based die adhesive used between the die and leadframe. The component is otherwise considered Pb-Free (RoHS compatible) as defined above.

**Green (RoHS & no Sb/Br):** TI defines "Green" to mean Pb-Free (RoHS compatible), and free of Bromine (Br) and Antimony (Sb) based flame retardants (Br or Sb do not exceed 0.1% by weight in homogeneous material)

<sup>(3)</sup> MSL, Peak Temp. -- The Moisture Sensitivity Level rating according to the JEDEC industry standard classifications, and peak solder temperature.

**Important Information and Disclaimer:**The information provided on this page represents TI's knowledge and belief as of the date that it is provided. TI bases its knowledge and belief on information provided by third parties, and makes no representation or warranty as to the accuracy of such information. Efforts are underway to better integrate information from third parties. TI has taken and continues to take reasonable steps to provide representative and accurate information but may not have conducted destructive testing or chemical analysis on incoming materials and chemicals. TI and TI suppliers consider certain information to be proprietary, and thus CAS numbers and other limited information may not be available for release.

In no event shall TI's liability arising out of such information exceed the total purchase price of the TI part(s) at issue in this document sold by TI to Customer on an annual basis.

NT (R-PDIP-T\*\*)

PLASTIC DUAL-IN-LINE PACKAGE

24 PINS SHOWN

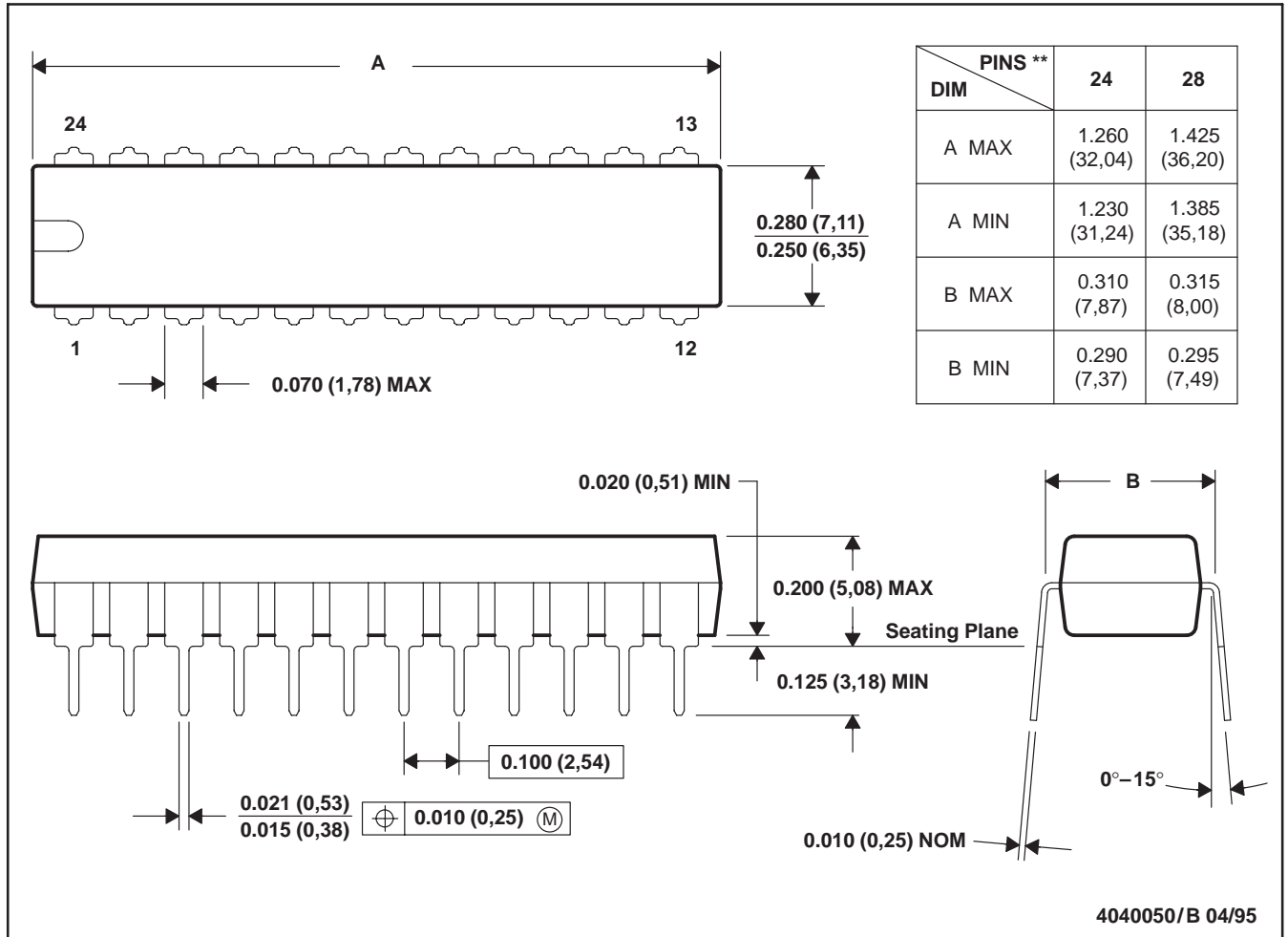

- NOTES: A. All linear dimensions are in inches (millimeters).  
 B. This drawing is subject to change without notice.

DW (R-PDSO-G24)

PLASTIC SMALL-OUTLINE PACKAGE

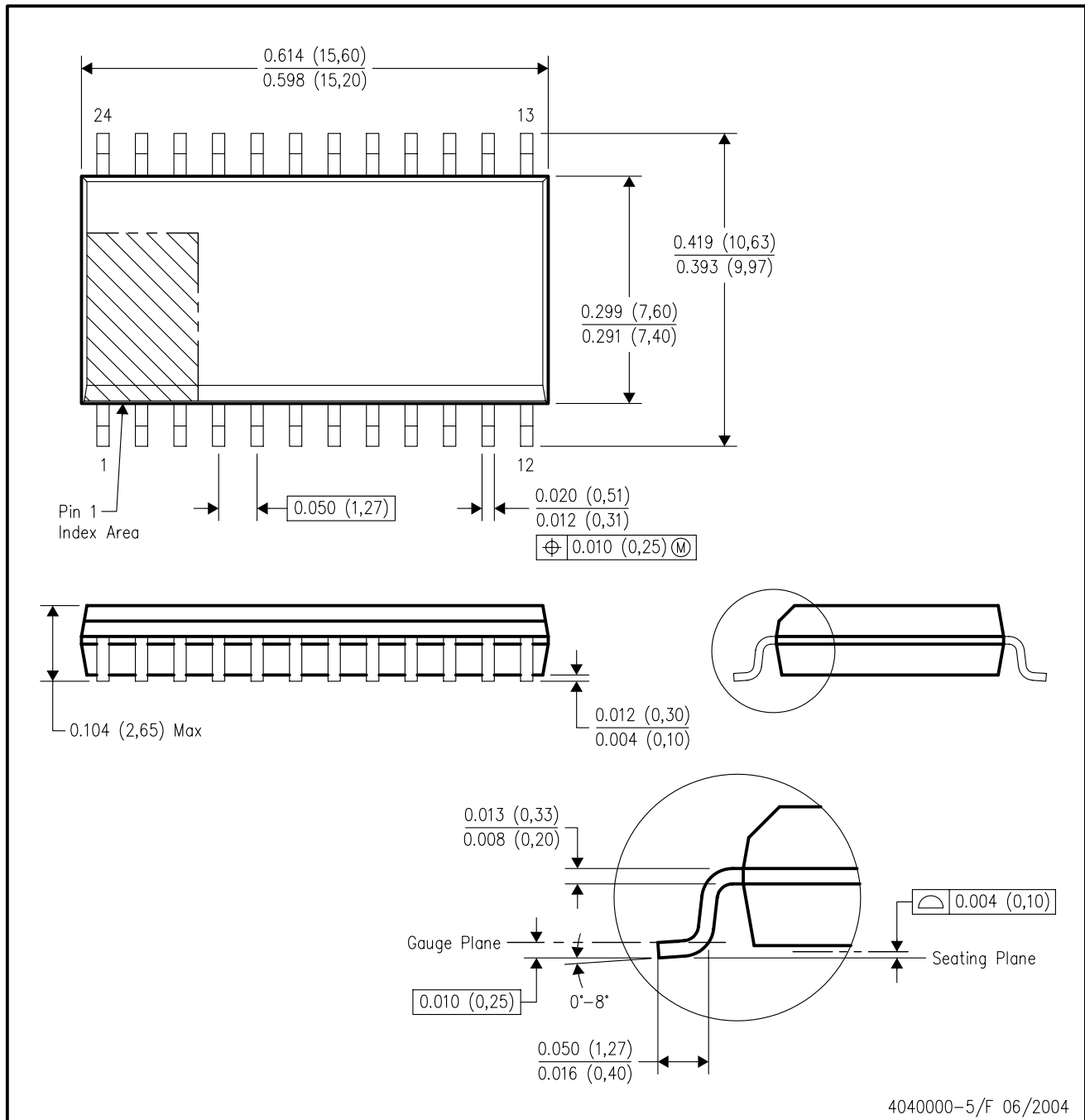

- NOTES:
- A. All linear dimensions are in inches (millimeters).
  - B. This drawing is subject to change without notice.
  - C. Body dimensions do not include mold flash or protrusion not to exceed 0.006 (0,15).
  - D. Falls within JEDEC MS-013 variation AD.

# MECHANICAL DATA

NS (R-PDSO-G\*\*)

PLASTIC SMALL-OUTLINE PACKAGE

14-PINS SHOWN



- NOTES:
- A. All linear dimensions are in millimeters.
  - B. This drawing is subject to change without notice.
  - C. Body dimensions do not include mold flash or protrusion, not to exceed 0,15.

## IMPORTANT NOTICE

Texas Instruments Incorporated and its subsidiaries (TI) reserve the right to make corrections, modifications, enhancements, improvements, and other changes to its products and services at any time and to discontinue any product or service without notice. Customers should obtain the latest relevant information before placing orders and should verify that such information is current and complete. All products are sold subject to TI's terms and conditions of sale supplied at the time of order acknowledgment.

TI warrants performance of its hardware products to the specifications applicable at the time of sale in accordance with TI's standard warranty. Testing and other quality control techniques are used to the extent TI deems necessary to support this warranty. Except where mandated by government requirements, testing of all parameters of each product is not necessarily performed.

TI assumes no liability for applications assistance or customer product design. Customers are responsible for their products and applications using TI components. To minimize the risks associated with customer products and applications, customers should provide adequate design and operating safeguards.

TI does not warrant or represent that any license, either express or implied, is granted under any TI patent right, copyright, mask work right, or other TI intellectual property right relating to any combination, machine, or process in which TI products or services are used. Information published by TI regarding third-party products or services does not constitute a license from TI to use such products or services or a warranty or endorsement thereof. Use of such information may require a license from a third party under the patents or other intellectual property of the third party, or a license from TI under the patents or other intellectual property of TI.

Reproduction of information in TI data books or data sheets is permissible only if reproduction is without alteration and is accompanied by all associated warranties, conditions, limitations, and notices. Reproduction of this information with alteration is an unfair and deceptive business practice. TI is not responsible or liable for such altered documentation.

Resale of TI products or services with statements different from or beyond the parameters stated by TI for that product or service voids all express and any implied warranties for the associated TI product or service and is an unfair and deceptive business practice. TI is not responsible or liable for any such statements.

Following are URLs where you can obtain information on other Texas Instruments products and application solutions:

<b>Products</b>		<b>Applications</b>	
Amplifiers	<a href="http://amplifier.ti.com">amplifier.ti.com</a>	Audio	<a href="http://www.ti.com/audio">www.ti.com/audio</a>
Data Converters	<a href="http://dataconverter.ti.com">dataconverter.ti.com</a>	Automotive	<a href="http://www.ti.com/automotive">www.ti.com/automotive</a>
DSP	<a href="http://dsp.ti.com">dsp.ti.com</a>	Broadband	<a href="http://www.ti.com/broadband">www.ti.com/broadband</a>
Interface	<a href="http://interface.ti.com">interface.ti.com</a>	Digital Control	<a href="http://www.ti.com/digitalcontrol">www.ti.com/digitalcontrol</a>
Logic	<a href="http://logic.ti.com">logic.ti.com</a>	Military	<a href="http://www.ti.com/military">www.ti.com/military</a>
Power Mgmt	<a href="http://power.ti.com">power.ti.com</a>	Optical Networking	<a href="http://www.ti.com/opticalnetwork">www.ti.com/opticalnetwork</a>
Microcontrollers	<a href="http://microcontroller.ti.com">microcontroller.ti.com</a>	Security	<a href="http://www.ti.com/security">www.ti.com/security</a>
Low Power Wireless	<a href="http://www.ti.com/lpw">www.ti.com/lpw</a>	Telephony	<a href="http://www.ti.com/telephony">www.ti.com/telephony</a>
		Video & Imaging	<a href="http://www.ti.com/video">www.ti.com/video</a>
		Wireless	<a href="http://www.ti.com/wireless">www.ti.com/wireless</a>

Mailing Address: Texas Instruments  
Post Office Box 655303 Dallas, Texas 75265