

SN54ABT657A, SN74ABT657A OCTAL TRANSCEIVERS WITH PARITY GENERATORS/CHECKERS AND 3-STATE OUTPUTS

SCBS192E – JANUARY 1991 – REVISED JUNE 1997

- State-of-the-Art *EPIC-II^B*™ BiCMOS Design Significantly Reduces Power Dissipation
- ESD Protection Exceeds 2000 V Per MIL-STD-883, Method 3015; Exceeds 200 V Using Machine Model (C = 200 pF, R = 0)
- Latch-Up Performance Exceeds 500 mA Per JEDEC Standard JESD-17
- Typical V_{OLP} (Output Ground Bounce) < 1 V at $V_{CC} = 5$ V, $T_A = 25^\circ\text{C}$
- High-Impedance State During Power Up and Power Down
- Flow-Through Architecture Optimizes PCB Layout
- High-Drive Outputs (–32-mA I_{OH} , 64-mA I_{OL})
- Package Options Include Plastic Small-Outline (DW) Packages, Ceramic Chip Carriers (FK), and Plastic (NT) and Ceramic (JT) DIPs

description

The 'ABT657A transceivers have eight noninverting buffers with parity-generator/checker circuits and control signals. The transmit/receive (T/\bar{R}) input determines the direction of data flow. When T/\bar{R} is high, data flows from the A port to the B port (transmit mode); when T/\bar{R} is low, data flows from the B port to the A port (receive mode). When the output-enable (\overline{OE}) input is high, both the A and B ports are in the high-impedance state.

Odd or even parity is selected by a logic high or low level on the ODD/\overline{EVEN} input. $PARITY$ carries the parity-bit value; it is an output from the parity generator/checker in the transmit mode and an input to the parity generator/checker in the receive mode.

In the transmit mode, after the A bus is polled to determine the number of high bits, $PARITY$ is set to the logic level that maintains the parity sense selected by the level at ODD/\overline{EVEN} . For example, if ODD/\overline{EVEN} is low (even parity selected) and there are five high bits on the A bus, $PARITY$ is set to the logic high level so that an even number of the nine total bits (eight A-bus bits plus parity bit) are high.

In the receive mode, after the B bus is polled to determine the number of high bits, the error (\overline{ERR}) output logic level indicates whether or not the data to be received exhibits the correct parity sense. For example, if ODD/\overline{EVEN} is high (odd parity selected), $PARITY$ is high, and there are three high bits on the B bus, \overline{ERR} is low, indicating a parity error.

SN54ABT657A . . . JT PACKAGE
SN74ABT657A . . . DW OR NT PACKAGE
(TOP VIEW)

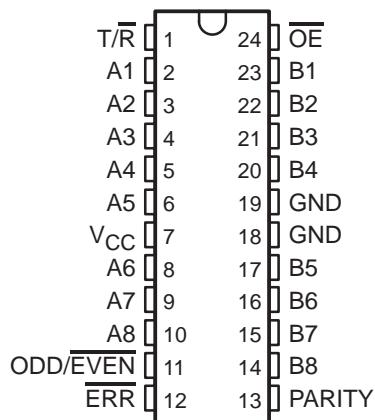

SN54ABT657A . . . FK PACKAGE
(TOP VIEW)

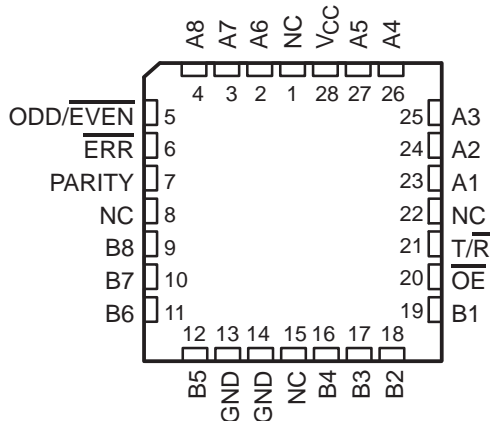

NC – No internal connection



Please be aware that an important notice concerning availability, standard warranty, and use in critical applications of Texas Instruments semiconductor products and disclaimers thereto appears at the end of this data sheet.

EPIC-II^B is a trademark of Texas Instruments Incorporated.

UNLESS OTHERWISE NOTED this document contains PRODUCTION DATA information current as of publication date. Products conform to specifications per the terms of Texas Instruments standard warranty. Production processing does not necessarily include testing of all parameters.

**TEXAS
INSTRUMENTS**

POST OFFICE BOX 655303 • DALLAS, TEXAS 75265

Copyright © 1997, Texas Instruments Incorporated

SN54ABT657A, SN74ABT657A OCTAL TRANSCEIVERS WITH PARITY GENERATORS/CHECKERS AND 3-STATE OUTPUTS

SCBS192E – JANUARY 1991 – REVISED JUNE 1997

description (continued)

When V_{CC} is between 0 and 2.1 V, the device is in the high-impedance state during power up or power down. However, to ensure the high-impedance state above 2.1 V, \overline{OE} should be tied to V_{CC} through a pullup resistor; the minimum value of the resistor is determined by the current-sinking capability of the driver.

The SN54ABT657A is characterized for operation over the full military temperature range of -55°C to 125°C . The SN74ABT657A is characterized for operation from -40°C to 85°C .

FUNCTION TABLE

NUMBER OF A OR B INPUTS THAT ARE HIGH	INPUTS			I/O PARITY	OUTPUTS	
	\overline{OE}	$\overline{T/R}$	ODD/ \overline{EVEN}		\overline{ERR}	OUTPUT MODE
0, 2, 4, 6, 8	L	H	H	H	Z	Transmit
	L	H	L	L	Z	Transmit
	L	L	H	H	H	Receive
	L	L	H	L	L	Receive
	L	L	L	H	L	Receive
	L	L	L	L	H	Receive
1, 3, 5, 7	L	H	H	L	Z	Transmit
	L	H	L	H	Z	Transmit
	L	L	H	H	L	Receive
	L	L	H	L	H	Receive
	L	L	L	H	H	Receive
	L	L	L	L	L	Receive
Don't care	H	X	X	Z	Z	Z



SN54ABT657A, SN74ABT657A OCTAL TRANSCEIVERS WITH PARITY GENERATORS/CHECKERS AND 3-STATE OUTPUTS

SCBS192E – JANUARY 1991 – REVISED JUNE 1997

logic symbol†

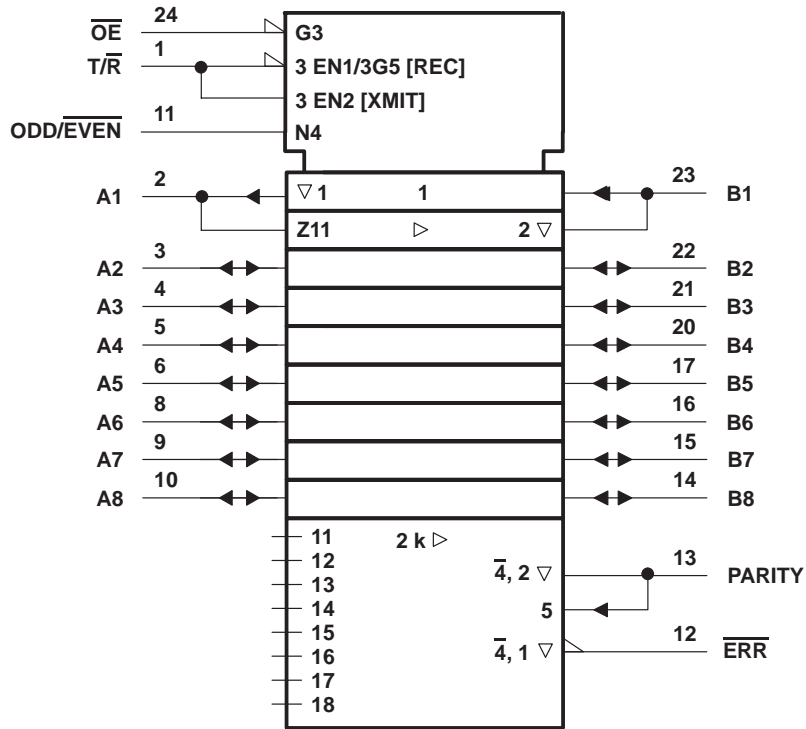

† This symbol is in accordance with ANSI/IEEE Std 91-1984 and IEC Publication 617-12. Pin numbers shown are for the DW, JT, and NT packages.

SN54ABT657A, SN74ABT657A OCTAL TRANSCEIVERS WITH PARITY GENERATORS/CHECKERS AND 3-STATE OUTPUTS

SCBS192E – JANUARY 1991 – REVISED JUNE 1997

logic diagram (positive logic)

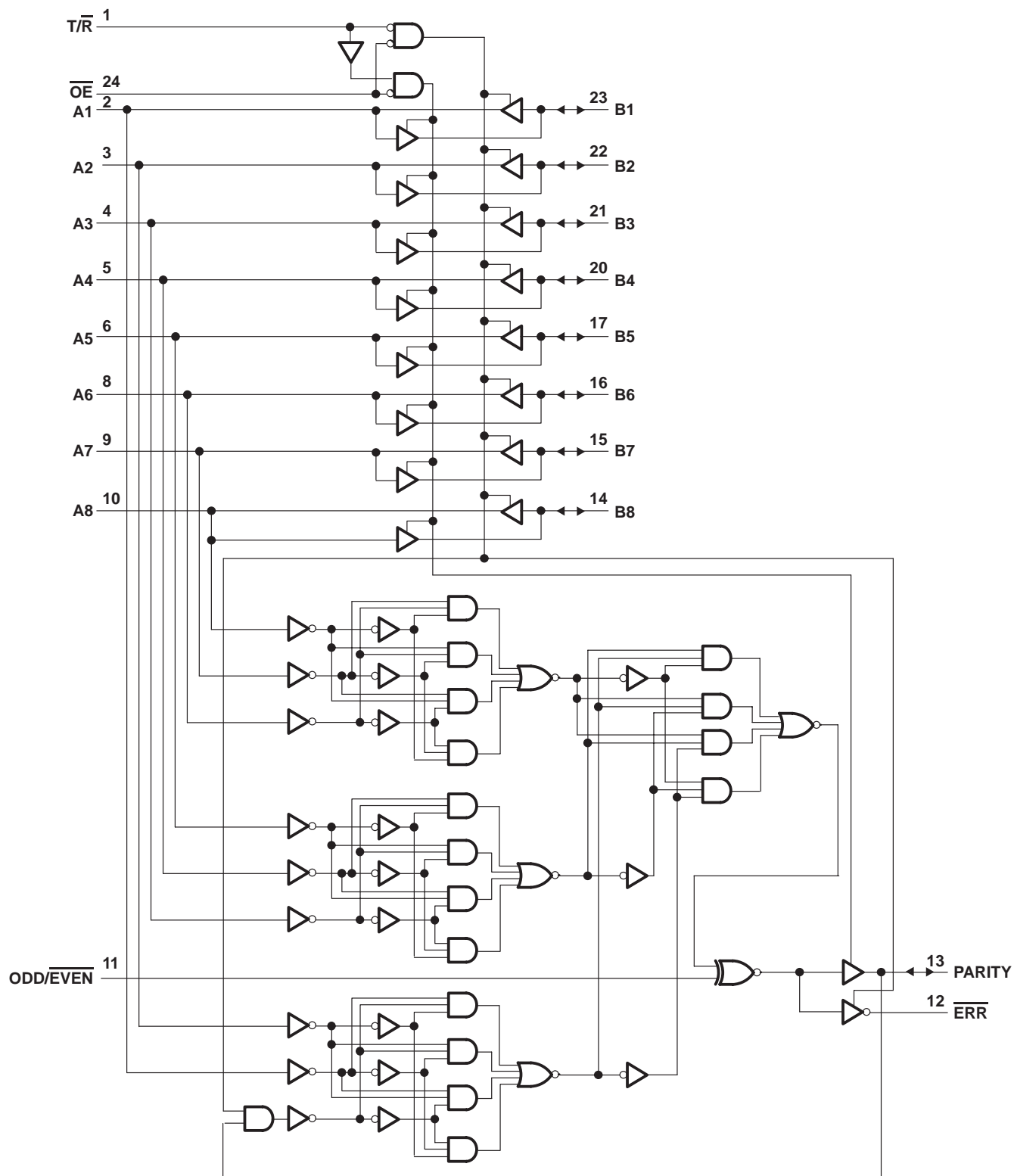

Pin numbers shown are for the DW, JT, and NT packages.



POST OFFICE BOX 655303 • DALLAS, TEXAS 75265

SN54ABT657A, SN74ABT657A OCTAL TRANSCEIVERS WITH PARITY GENERATORS/CHECKERS AND 3-STATE OUTPUTS

SCBS192E – JANUARY 1991 – REVISED JUNE 1997

absolute maximum ratings over operating free-air temperature range (unless otherwise noted)†

Supply voltage range, V_{CC}	–0.5 V to 7 V
Input voltage range, V_I (except I/O ports) (see Note 1)	–0.5 V to 7 V
Voltage range applied to any output in the high or power-off state, V_O	–0.5 V to 5.5 V
Current into any output in the low state, I_O : SN54ABT657A	96 mA
SN74ABT657A	128 mA
Input clamp current, I_{IK} ($V_I < 0$)	–18 mA
Output clamp current, I_{OK} ($V_O < 0$)	–50 mA
Package thermal impedance, θ_{JA} (see Note 2): DW package	81°C/W
NT package	67°C/W
Storage temperature range, T_{stg}	–65°C to 150°C

† Stresses beyond those listed under “absolute maximum ratings” may cause permanent damage to the device. These are stress ratings only, and functional operation of the device at these or any other conditions beyond those indicated under “recommended operating conditions” is not implied. Exposure to absolute-maximum-rated conditions for extended periods may affect device reliability.

- NOTES: 1. The input and output negative-voltage ratings may be exceeded if the input and output clamp-current ratings are observed.
 2. The package thermal impedance is calculated in accordance with EIA/JEDEC Std JESD51, except for through-hole packages, which use a trace length of zero.

recommended operating conditions (see Note 3)

		SN54ABT657A		SN74ABT657A		UNIT
		MIN	MAX	MIN	MAX	
V_{CC}	Supply voltage	4.5	5.5	4.5	5.5	V
V_{IH}	High-level input voltage	2		2		V
V_{IL}	Low-level input voltage		0.8		0.8	V
V_I	Input voltage	0	V_{CC}	0	V_{CC}	V
I_{OH}	High-level output current		–24		–32	mA
I_{OL}	Low-level output current		48		64	mA
$\Delta t/\Delta v$	Input transition rise or fall rate	Outputs enabled			5	ns/V
$\Delta t/\Delta V_{CC}$	Power-up ramp rate	200		200		μ s/V
T_A	Operating free-air temperature	–55	125	–40	85	°C

NOTE 3: Unused pins (input or I/O) must be held high or low to prevent them from floating.

SN54ABT657A, SN74ABT657A OCTAL TRANSCEIVERS WITH PARITY GENERATORS/CHECKERS AND 3-STATE OUTPUTS

SCBS192E – JANUARY 1991 – REVISED JUNE 1997

electrical characteristics over recommended operating free-air temperature range (unless otherwise noted)

PARAMETER	TEST CONDITIONS		T _A = 25°C			SN54ABT657A		SN74ABT657A		UNIT	
			MIN	TYP†	MAX	MIN	MAX	MIN	MAX		
V _{IK}	V _{CC} = 4.5 V, I _I = -18 mA		-1.2			-1.2		-1.2		V	
V _{OH}	V _{CC} = 4.5 V, I _{OH} = -3 mA		2.5			2.5		2.5		V	
	V _{CC} = 5 V, I _{OH} = -3 mA		3			3		3			
	V _{CC} = 4.5 V	I _{OH} = -24 mA	2			2					
I _{OH} = -32 mA		2*					2				
V _{OL}	V _{CC} = 4.5 V		I _{OL} = 48 mA			0.55		0.55		V	
			I _{OL} = 64 mA			0.55*			0.55		
V _{hys}			100							mV	
I _I	Control inputs	V _{CC} = 0 to 5.5 V, V _I = V _{CC} or GND		±1			±1		±1		
	A or B ports	V _{CC} = 2.1 V to 5.5 V, V _I = V _{CC} or GND		±20			±20		±20		
I _{OZPU} ‡	V _{CC} = 0 to 2.1 V, V _O = 0.5 V to 2.7 V, $\overline{OE} = X$		±50			±50		±50		µA	
I _{OZPD} ‡	V _{CC} = 2.1 V to 0, V _O = 0.5 V to 2.7 V, $\overline{OE} = X$		±50			±50		±50		µA	
I _{OZH} §	V _{CC} = 2.1 V to 5.5 V, V _O = 2.7 V, $\overline{OE} \geq 2 V$		10			10		10		µA	
I _{OZL} §	V _{CC} = 2.1 V to 5.5 V, V _O = 0.5 V, $\overline{OE} \geq 2 V$		-10			-10		-10		µA	
I _{off}	V _{CC} = 0, V _I or V _O ≤ 4.5 V		±100					±100		µA	
I _{CEX}	V _{CC} = 5.5 V, V _O = 5.5 V	Outputs high		50			50		50		
I _O ¶	V _{CC} = 5.5 V, V _O = 2.5 V		-50	-100	-200	-50	-200	-50	-200	mA	
I _{CC}	V _{CC} = 5.5 V, I _O = 0, V _I = V _{CC} or GND		Outputs high		250			250		250	
			Outputs low		40			40		40	
			Outputs disabled		250			250		250	
ΔI _{CC} #	Data inputs	V _{CC} = 5.5 V, One input at 3.4 V, Other inputs at V _{CC} or GND		Outputs enabled		1.5			1.5		mA
				Outputs disabled		0.25			0.25		
	Control inputs	V _{CC} = 5.5 V, One input at 3.4 V, Other inputs at V _{CC} or GND		1.5			1.5		1.5		
C _i	Control inputs	V _I = 2.5 V or 0.5 V		4					pF		
C _{io}	A or B ports	V _O = 2.5 V or 0.5 V		10					pF		

* On products compliant to MIL-PRF-38535, this parameter does not apply.

† All typical values are at V_{CC} = 5 V.

‡ This parameter is characterized, but not production tested.

§ The parameters I_{OZH} and I_{OZL} include the input leakage current.

¶ Not more than one output should be tested at a time, and the duration of the test should not exceed one second.

This is the increase in supply current for each input that is at the specified TTL voltage level rather than V_{CC} or GND.

PRODUCT PREVIEW information concerns products in the formative or design phase of development. Characteristic data and other specifications are design goals. Texas Instruments reserves the right to change or discontinue these products without notice.



POST OFFICE BOX 655303 • DALLAS, TEXAS 75265

SN54ABT657A, SN74ABT657A OCTAL TRANSCEIVERS WITH PARITY GENERATORS/CHECKERS AND 3-STATE OUTPUTS

SCBS192E – JANUARY 1991 – REVISED JUNE 1997

switching characteristics over recommended ranges of supply voltage and operating free-air temperature, $C_L = 50$ pF (unless otherwise noted) (see Figure 1)

PARAMETER	FROM (INPUT)	TO (OUTPUT)	$V_{CC} = 5$ V, $T_A = 25^\circ$ C			SN54ABT657A		SN74ABT657A		UNIT
			MIN	TYP	MAX	MIN	MAX	MIN	MAX	
t_{PLH}	A or B	B or A	1	3.2	4.2	1	5	1	4.6	ns
t_{PHL}			1	2.8	3.8	1	4.5	1	4.3	
t_{PLH}	A	PARITY	1.8	4.8	6.3	1.8	8.5	1.8	8.1	ns
t_{PHL}			2.3	4.9	6.4	2.3	8.1	2.3	7.7	
t_{PLH}	ODD/EVEN	PARITY, \overline{ERR}	1.1	3.3	4.2	1.1	5.3	1.1	4.9	ns
t_{PHL}			1.3	3.4	4.5	1.3	5.1	1.3	4.9	
t_{PLH}	B	\overline{ERR}	1.6	4.7	6.5	1.6	8.4	1.6	7.9	ns
t_{PHL}			2.1	4.9	6.9	2.1	8	2.1	7.8	
t_{PLH}	PARITY	\overline{ERR}	2	4.8	6.3	2	8.1	2	7.7	ns
t_{PHL}			2.1	4.9	6.7	2.1	8	2.1	7.5	
t_{PZH}	\overline{OE}	A, B, PARITY	1.4	4	5.4	1.4	6.8	1.4	6.5	ns
t_{PZL}			1.7	4.1	5.8	1.7	6.7	1.7	6.5	
t_{PZH}	\overline{OE}	\overline{ERR}	1.8	4.1	5.4	1.8	6.9	1.8	6.6	ns
t_{PZL}			3.3	6.2	7.6	3.3	9.7	3.3	9.2	
t_{PHZ}	\overline{OE}	A, B, PARITY, or \overline{ERR}	2.4	4.2	5.6	2.4	6.3	2.4	6.2	ns
t_{PLZ}			1.8	4.2	6.2	1.8	8.9	1.8	7.8	

PRODUCT PREVIEW information concerns products in the formative or design phase of development. Characteristic data and other specifications are design goals. Texas Instruments reserves the right to change or discontinue these products without notice.



POST OFFICE BOX 655303 • DALLAS, TEXAS 75265

SN54ABT657A, SN74ABT657A OCTAL TRANSCEIVERS WITH PARITY GENERATORS/CHECKERS AND 3-STATE OUTPUTS

SCBS192E – JANUARY 1991 – REVISED JUNE 1997

PARAMETER MEASUREMENT INFORMATION

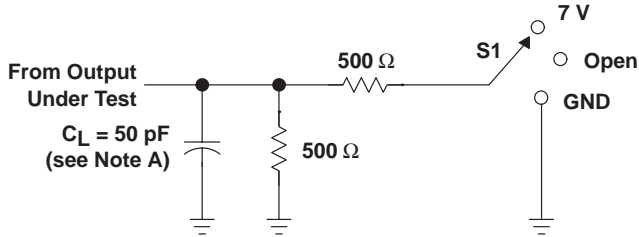

LOAD CIRCUIT

TEST	S1
t_{PLH}/t_{PHL}	Open
t_{PLZ}/t_{PZL}	7 V
t_{PHZ}/t_{PZH}	Open

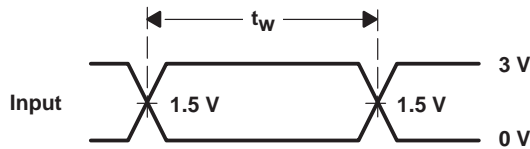

VOLTAGE WAVEFORMS
PULSE DURATION

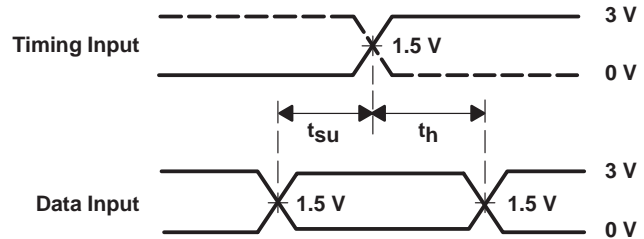

VOLTAGE WAVEFORMS
SETUP AND HOLD TIMES

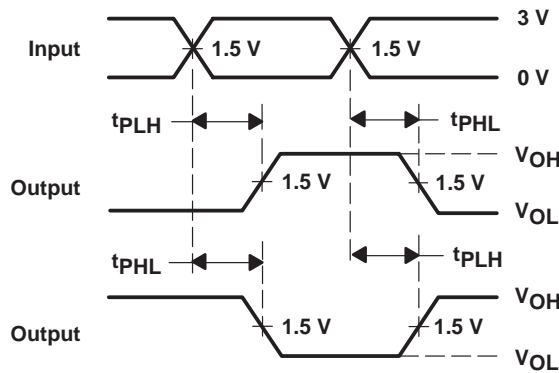

VOLTAGE WAVEFORMS
PROPAGATION DELAY TIMES
INVERTING AND NONINVERTING OUTPUTS

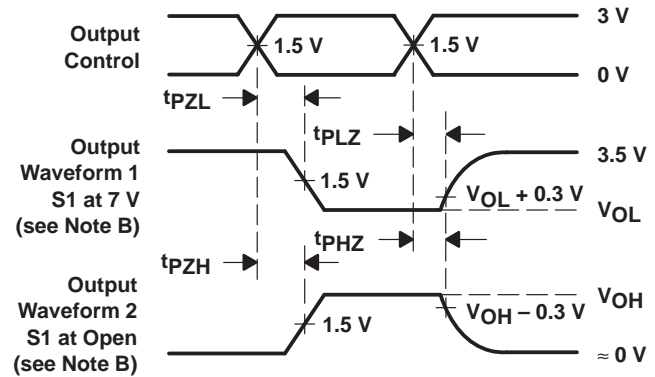

VOLTAGE WAVEFORMS
ENABLE AND DISABLE TIMES
LOW- AND HIGH-LEVEL ENABLING

- NOTES: A. C_L includes probe and jig capacitance.
B. Waveform 1 is for an output with internal conditions such that the output is low except when disabled by the output control. Waveform 2 is for an output with internal conditions such that the output is high except when disabled by the output control.
C. All input pulses are supplied by generators having the following characteristics: $PRR \leq 10 \text{ MHz}$, $Z_O = 50 \Omega$, $t_r \leq 2.5 \text{ ns}$, $t_f \leq 2.5 \text{ ns}$.
D. The outputs are measured one at a time with one transition per measurement.

Figure 1. Load Circuit and Voltage Waveforms

PACKAGING INFORMATION

Orderable Device	Status ⁽¹⁾	Package Type	Package Drawing	Pins	Package Qty	Eco Plan ⁽²⁾	Lead/Ball Finish	MSL Peak Temp ⁽³⁾
SN74ABT657ADBLE	OBSOLETE	SSOP	DB	24		TBD	Call TI	Call TI
SN74ABT657ADBR	ACTIVE	SSOP	DB	24	2000	Green (RoHS & no Sb/Br)	CU NIPDAU	Level-1-260C-UNLIM
SN74ABT657ADBRE4	ACTIVE	SSOP	DB	24	2000	Green (RoHS & no Sb/Br)	CU NIPDAU	Level-1-260C-UNLIM
SN74ABT657ADW	ACTIVE	SOIC	DW	24	25	Green (RoHS & no Sb/Br)	CU NIPDAU	Level-1-260C-UNLIM
SN74ABT657ADWE4	ACTIVE	SOIC	DW	24	25	Green (RoHS & no Sb/Br)	CU NIPDAU	Level-1-260C-UNLIM
SN74ABT657ADWR	ACTIVE	SOIC	DW	24	2000	Green (RoHS & no Sb/Br)	CU NIPDAU	Level-1-260C-UNLIM
SN74ABT657ADWRE4	ACTIVE	SOIC	DW	24	2000	Green (RoHS & no Sb/Br)	CU NIPDAU	Level-1-260C-UNLIM
SN74ABT657ANSR	ACTIVE	SO	NS	24	2000	Green (RoHS & no Sb/Br)	CU NIPDAU	Level-1-260C-UNLIM
SN74ABT657ANSRE4	ACTIVE	SO	NS	24	2000	Green (RoHS & no Sb/Br)	CU NIPDAU	Level-1-260C-UNLIM
SN74ABT657ANT	ACTIVE	PDIP	NT	24	15	Pb-Free (RoHS)	CU NIPDAU	N / A for Pkg Type
SN74ABT657ANTE4	ACTIVE	PDIP	NT	24	15	Pb-Free (RoHS)	CU NIPDAU	N / A for Pkg Type

⁽¹⁾ The marketing status values are defined as follows:

ACTIVE: Product device recommended for new designs.

LIFEBUY: TI has announced that the device will be discontinued, and a lifetime-buy period is in effect.

NRND: Not recommended for new designs. Device is in production to support existing customers, but TI does not recommend using this part in a new design.

PREVIEW: Device has been announced but is not in production. Samples may or may not be available.

OBSOLETE: TI has discontinued the production of the device.

⁽²⁾ Eco Plan - The planned eco-friendly classification: Pb-Free (RoHS), Pb-Free (RoHS Exempt), or Green (RoHS & no Sb/Br) - please check <http://www.ti.com/productcontent> for the latest availability information and additional product content details.

TBD: The Pb-Free/Green conversion plan has not been defined.

Pb-Free (RoHS): TI's terms "Lead-Free" or "Pb-Free" mean semiconductor products that are compatible with the current RoHS requirements for all 6 substances, including the requirement that lead not exceed 0.1% by weight in homogeneous materials. Where designed to be soldered at high temperatures, TI Pb-Free products are suitable for use in specified lead-free processes.

Pb-Free (RoHS Exempt): This component has a RoHS exemption for either 1) lead-based flip-chip solder bumps used between the die and package, or 2) lead-based die adhesive used between the die and leadframe. The component is otherwise considered Pb-Free (RoHS compatible) as defined above.

Green (RoHS & no Sb/Br): TI defines "Green" to mean Pb-Free (RoHS compatible), and free of Bromine (Br) and Antimony (Sb) based flame retardants (Br or Sb do not exceed 0.1% by weight in homogeneous material)

⁽³⁾ MSL, Peak Temp. -- The Moisture Sensitivity Level rating according to the JEDEC industry standard classifications, and peak solder temperature.

Important Information and Disclaimer:The information provided on this page represents TI's knowledge and belief as of the date that it is provided. TI bases its knowledge and belief on information provided by third parties, and makes no representation or warranty as to the accuracy of such information. Efforts are underway to better integrate information from third parties. TI has taken and continues to take reasonable steps to provide representative and accurate information but may not have conducted destructive testing or chemical analysis on incoming materials and chemicals. TI and TI suppliers consider certain information to be proprietary, and thus CAS numbers and other limited information may not be available for release.

In no event shall TI's liability arising out of such information exceed the total purchase price of the TI part(s) at issue in this document sold by TI to Customer on an annual basis.

IMPORTANT NOTICE

Texas Instruments Incorporated and its subsidiaries (TI) reserve the right to make corrections, modifications, enhancements, improvements, and other changes to its products and services at any time and to discontinue any product or service without notice. Customers should obtain the latest relevant information before placing orders and should verify that such information is current and complete. All products are sold subject to TI's terms and conditions of sale supplied at the time of order acknowledgment.

TI warrants performance of its hardware products to the specifications applicable at the time of sale in accordance with TI's standard warranty. Testing and other quality control techniques are used to the extent TI deems necessary to support this warranty. Except where mandated by government requirements, testing of all parameters of each product is not necessarily performed.

TI assumes no liability for applications assistance or customer product design. Customers are responsible for their products and applications using TI components. To minimize the risks associated with customer products and applications, customers should provide adequate design and operating safeguards.

TI does not warrant or represent that any license, either express or implied, is granted under any TI patent right, copyright, mask work right, or other TI intellectual property right relating to any combination, machine, or process in which TI products or services are used. Information published by TI regarding third-party products or services does not constitute a license from TI to use such products or services or a warranty or endorsement thereof. Use of such information may require a license from a third party under the patents or other intellectual property of the third party, or a license from TI under the patents or other intellectual property of TI.

Reproduction of information in TI data books or data sheets is permissible only if reproduction is without alteration and is accompanied by all associated warranties, conditions, limitations, and notices. Reproduction of this information with alteration is an unfair and deceptive business practice. TI is not responsible or liable for such altered documentation.

Resale of TI products or services with statements different from or beyond the parameters stated by TI for that product or service voids all express and any implied warranties for the associated TI product or service and is an unfair and deceptive business practice. TI is not responsible or liable for any such statements.

Following are URLs where you can obtain information on other Texas Instruments products and application solutions:

Products		Applications	
Amplifiers	amplifier.ti.com	Audio	www.ti.com/audio
Data Converters	dataconverter.ti.com	Automotive	www.ti.com/automotive
DSP	dsp.ti.com	Broadband	www.ti.com/broadband
Interface	interface.ti.com	Digital Control	www.ti.com/digitalcontrol
Logic	logic.ti.com	Military	www.ti.com/military
Power Mgmt	power.ti.com	Optical Networking	www.ti.com/opticalnetwork
Microcontrollers	microcontroller.ti.com	Security	www.ti.com/security
Low Power Wireless	www.ti.com/lpw	Telephony	www.ti.com/telephony
		Video & Imaging	www.ti.com/video
		Wireless	www.ti.com/wireless

Mailing Address: Texas Instruments
Post Office Box 655303 Dallas, Texas 75265