

SN54ABT2827, SN74ABT2827 10-BIT BUFFERS/DRIVERS WITH 3-STATE OUTPUTS

SCBS648A – DECEMBER 1995 – REVISED JANUARY 1997

- Output Ports Have Equivalent 25- Ω Series Resistors, So No External Resistors Are Required
- State-of-the-Art EPIC-IIB™ BiCMOS Design Significantly Reduces Power Dissipation
- Flow-Through Architecture Optimizes PCB Layout
- Latch-Up Performance Exceeds 500 mA Per JEDEC Standard JESD-17
- Typical V_{OLP} (Output Ground Bounce) < 1 V at $V_{CC} = 5$ V, $T_A = 25^\circ\text{C}$
- Package Options Include Plastic Small-Outline (DW) Package, Ceramic Chip Carriers (FK), and Plastic (NT) and Ceramic (JT) DIPs

description

These 10-bit buffers or bus drivers provide a high-performance bus interface for wide data paths or buses carrying parity.

The 3-state control gate is a 2-input AND gate with active-low inputs so that if either output-enable ($\overline{OE1}$ or $\overline{OE2}$) input is high, all ten outputs are in the high-impedance state. The 'ABT2827 provide true data at their outputs.

To ensure the high-impedance state during power up or power down, \overline{OE} should be tied to V_{CC} through a pullup resistor; the minimum value of the resistor is determined by the current-sinking capability of the driver.

The outputs, which are designed to source or sink up to 12 mA, include equivalent 25- Ω series resistors to reduce overshoot and undershoot.

The SN54ABT2827 is characterized for operation over the full military temperature range of -55°C to 125°C . The SN74ABT2827 is characterized for operation from -40°C to 85°C .

SN54ABT2827 . . . JT PACKAGE
SN74ABT2827 . . . DW OR NT PACKAGE
(TOP VIEW)

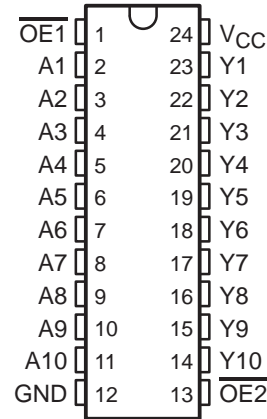

SN54ABT2827 . . . FK PACKAGE
(TOP VIEW)

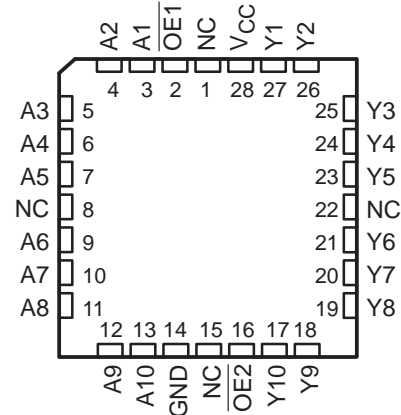

NC – No internal connection



Please be aware that an important notice concerning availability, standard warranty, and use in critical applications of Texas Instruments semiconductor products and disclaimers thereto appears at the end of this data sheet.

EPIC-IIB is a trademark of Texas Instruments Incorporated.

UNLESS OTHERWISE NOTED this document contains PRODUCTION DATA information current as of publication date. Products conform to specifications per the terms of Texas Instruments standard warranty. Production processing does not necessarily include testing of all parameters.



POST OFFICE BOX 655303 • DALLAS, TEXAS 75265

Copyright © 1997, Texas Instruments Incorporated

SN54ABT2827, SN74ABT2827 10-BIT BUFFERS/DRIVERS WITH 3-STATE OUTPUTS

SCBS648A – DECEMBER 1995 – REVISED JANUARY 1997

FUNCTION TABLE

INPUTS			OUTPUT Y
OE1	OE2	A	
L	L	L	L
L	L	H	H
H	X	X	Z
X	H	X	Z

logic symbol†

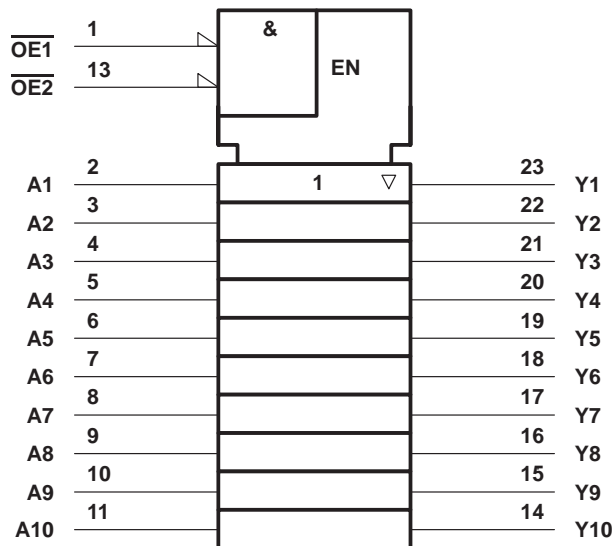

logic diagram (positive logic)

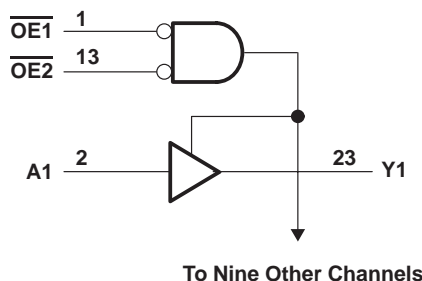

† This symbol is in accordance with ANSI/IEEE Std 91-1984 and IEC Publication 617-12.

Pin numbers shown are for the DW, JT, and NT packages.

absolute maximum ratings over operating free-air temperature range (unless otherwise noted)‡

Supply voltage range, V_{CC}	-0.5 V to 7 V
Input voltage range, V_I (see Note 1)	-0.5 V to 7 V
Voltage range applied to any output in the high or power-off state, V_O	-0.5 V to 5.5 V
Current into any output in the low state, I_O : SN54ABT2827	96 mA
SN74ABT2827	128 mA
Input clamp current, I_{IK} ($V_I < 0$)	-18 mA
Output clamp current, I_{OK} ($V_O < 0$)	-50 mA
Package thermal impedance, θ_{JA} (see Note 2): DW package	81°C/W
NT package	67°C/W
Storage temperature range, T_{stg}	-65°C to 150°C

‡ Stresses beyond those listed under “absolute maximum ratings” may cause permanent damage to the device. These are stress ratings only, and functional operation of the device at these or any other conditions beyond those indicated under “recommended operating conditions” is not implied. Exposure to absolute-maximum-rated conditions for extended periods may affect device reliability.

NOTES: 1. The input and output negative-voltage ratings may be exceeded if the input and output clamp-current ratings are observed.
2. The package thermal impedance is calculated in accordance with EIA/JEDEC Std JESD51, except for through-hole packages, which use a trace length of zero.

SN54ABT2827, SN74ABT2827 10-BIT BUFFERS/DRIVERS WITH 3-STATE OUTPUTS

SCBS648A – DECEMBER 1995 – REVISED JANUARY 1997

recommended operating conditions (see Note 3)

		SN54ABT2827		SN74ABT2827		UNIT
		MIN	MAX	MIN	MAX	
V_{CC}	Supply voltage	4.5	5.5	4.5	5.5	V
V_{IH}	High-level input voltage	2		2		V
V_{IL}	Low-level input voltage		0.8		0.8	V
V_I	Input voltage	0	V_{CC}	0	V_{CC}	V
I_{OH}	High-level output current		-12		-12	mA
I_{OL}	Low-level output current		12		12	mA
$\Delta t/\Delta v$	Input transition rise or fall rate		5		5	ns/V
T_A	Operating free-air temperature	-55	125	-40	85	°C

NOTE 3: Unused inputs must be held high or low to prevent them from floating.

electrical characteristics over recommended operating free-air temperature range (unless otherwise noted)

PARAMETER	TEST CONDITIONS		$T_A = 25^\circ\text{C}$			SN54ABT2827		SN74ABT2827		UNIT
			MIN	TYP†	MAX	MIN	MAX	MIN	MAX	
V_{IK}	$V_{CC} = 4.5\text{ V}$,	$I_I = -18\text{ mA}$			-1.2		-1.2		-1.2	V
V_{OH}	$V_{CC} = 4.5\text{ V}$,	$I_{OH} = -1\text{ mA}$	2.5			2.5		2.5		V
	$V_{CC} = 5\text{ V}$,	$I_{OH} = -1\text{ mA}$	3			3		3		
	$V_{CC} = 4.5\text{ V}$	$I_{OH} = -3\text{ mA}$	2.4			2.4		2.4		
		$I_{OH} = -12\text{ mA}$	2			2		2		
V_{OL}	$V_{CC} = 4.5\text{ V}$	$I_{OL} = 12\text{ mA}$			0.8		0.8		0.8	V
V_{hys}				100						mV
I_I	$V_{CC} = 0\text{ to }5.5\text{ V}$,	$V_I = V_{CC}\text{ or GND}$			± 1		± 1		± 1	μA
I_{OZH}	$V_{CC} = 5.5\text{ V}$,	$V_O = 2.7\text{ V}$			10^\ddagger		10		10^\ddagger	μA
I_{OZL}	$V_{CC} = 5.5\text{ V}$,	$V_O = 0.5\text{ V}$			-10^\ddagger		-10		-10^\ddagger	μA
I_{off}	$V_{CC} = 0$,	$V_I\text{ or }V_O \leq 4.5\text{ V}$			± 100				± 100	μA
I_{CEX}	$V_{CC} = 5.5\text{ V}$, $V_O = 5.5\text{ V}$	Outputs high			50		50		50	μA
I_O^\S	$V_{CC} = 5.5\text{ V}$,	$V_O = 2.5\text{ V}$	-50	-140	-225^\ddagger	-50	-225^\ddagger	-50	-225^\ddagger	mA
I_{CC}	$V_{CC} = 5.5\text{ V}$, $I_O = 0$, $V_I = V_{CC}\text{ or GND}$	Outputs high	80	250		250		250		μA
		Outputs low	35	40^\ddagger		40^\ddagger		40^\ddagger		mA
		Outputs disabled	80	250		250		250		μA
ΔI_{CC}^\parallel	$V_{CC} = 5.5\text{ V}$, One input at 3.4 V, Other inputs at $V_{CC}\text{ or GND}$	Outputs enabled		1.5		1.5		1.5		mA
		Outputs disabled		50		50		50		μA
		Control inputs		1.5		1.5		1.5		mA
C_i	$V_I = 2.5\text{ V or }0.5\text{ V}$			4						pF
C_o	$V_O = 2.5\text{ V or }0.5\text{ V}$			8.5						pF

† All typical values are at $V_{CC} = 5\text{ V}$, $T_A = 25^\circ\text{C}$.

‡ This data sheet limit may vary among suppliers.

§ Not more than one output should be tested at a time, and the duration of the test should not exceed one second.

¶ This is the increase in supply current for each input that is at the specified TTL voltage level rather than V_{CC} or GND.

PRODUCT PREVIEW information concerns products in the formative or design phase of development. Characteristic data and other specifications are design goals. Texas Instruments reserves the right to change or discontinue these products without notice.



POST OFFICE BOX 655303 • DALLAS, TEXAS 75265

SN54ABT2827, SN74ABT2827
10-BIT BUFFERS/DRIVERS
WITH 3-STATE OUTPUTS

SCBS648A – DECEMBER 1995 – REVISED JANUARY 1997

switching characteristics over recommended ranges of supply voltage and operating free-air temperature, $C_L = 50$ pF (unless otherwise noted) (see Figure 1)

PARAMETER	FROM (INPUT)	TO (OUTPUT)	$V_{CC} = 5$ V, $T_A = 25^\circ$ C			SN54ABT2827		SN74ABT2827		UNIT
			MIN	TYP	MAX	MIN	MAX	MIN	MAX	
t_{PLH}	A	Y	1.1	3.3	5.1	1.1	5.6	1.1	5.5	ns
t_{PHL}			1.1	2.7	4.5	1.1	5.2	1.1	5.1	
t_{PZH}	\overline{OE}	Y	1	4	5.9	1	6.8	1	6.7	ns
t_{PZL}			1	4.2	6.8	1	8	1	7.8	
t_{PHZ}	\overline{OE}	Y	2	5.3	6.7	2	7.4	2	7.2	ns
t_{PLZ}			1.3	4.8	7.2	1.3	8.5	1.3	7.5	

PRODUCT PREVIEW information concerns products in the formative or design phase of development. Characteristic data and other specifications are design goals. Texas Instruments reserves the right to change or discontinue these products without notice.



POST OFFICE BOX 655303 • DALLAS, TEXAS 75265

PARAMETER MEASUREMENT INFORMATION

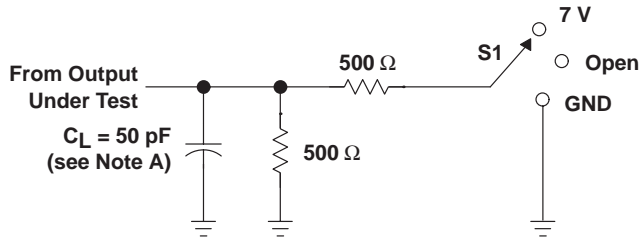

LOAD CIRCUIT

TEST	S1
t_{PLH}/t_{PHL}	Open
t_{PLZ}/t_{PZL}	7 V
t_{PHZ}/t_{PZH}	Open

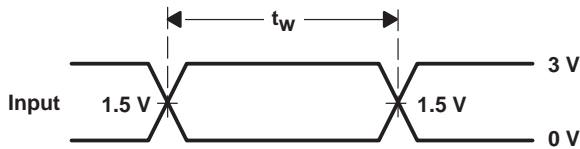

VOLTAGE WAVEFORMS
PULSE DURATION

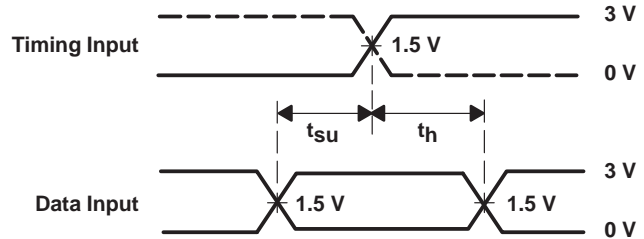

VOLTAGE WAVEFORMS
SETUP AND HOLD TIMES

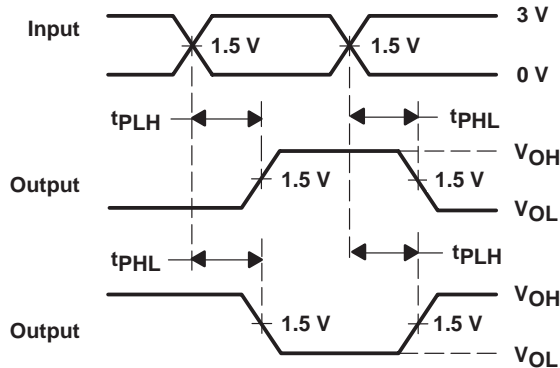

VOLTAGE WAVEFORMS
PROPAGATION DELAY TIMES
INVERTING AND NONINVERTING OUTPUTS

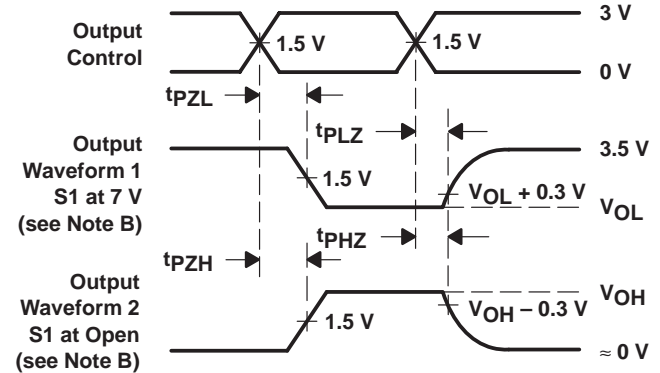

VOLTAGE WAVEFORMS
ENABLE AND DISABLE TIMES
LOW- AND HIGH-LEVEL ENABLING

- NOTES: A. C_L includes probe and jig capacitance.
B. Waveform 1 is for an output with internal conditions such that the output is low except when disabled by the output control.
Waveform 2 is for an output with internal conditions such that the output is high except when disabled by the output control.
C. All input pulses are supplied by generators having the following characteristics: $PRR \leq 10 \text{ MHz}$, $Z_O = 50 \Omega$, $t_r \leq 2.5 \text{ ns}$, $t_f \leq 2.5 \text{ ns}$.
D. The outputs are measured one at a time with one transition per measurement.

Figure 1. Load Circuit and Voltage Waveforms

IMPORTANT NOTICE

Texas Instruments and its subsidiaries (TI) reserve the right to make changes to their products or to discontinue any product or service without notice, and advise customers to obtain the latest version of relevant information to verify, before placing orders, that information being relied on is current and complete. All products are sold subject to the terms and conditions of sale supplied at the time of order acknowledgement, including those pertaining to warranty, patent infringement, and limitation of liability.

TI warrants performance of its semiconductor products to the specifications applicable at the time of sale in accordance with TI's standard warranty. Testing and other quality control techniques are utilized to the extent TI deems necessary to support this warranty. Specific testing of all parameters of each device is not necessarily performed, except those mandated by government requirements.

CERTAIN APPLICATIONS USING SEMICONDUCTOR PRODUCTS MAY INVOLVE POTENTIAL RISKS OF DEATH, PERSONAL INJURY, OR SEVERE PROPERTY OR ENVIRONMENTAL DAMAGE ("CRITICAL APPLICATIONS"). TI SEMICONDUCTOR PRODUCTS ARE NOT DESIGNED, AUTHORIZED, OR WARRANTED TO BE SUITABLE FOR USE IN LIFE-SUPPORT DEVICES OR SYSTEMS OR OTHER CRITICAL APPLICATIONS. INCLUSION OF TI PRODUCTS IN SUCH APPLICATIONS IS UNDERSTOOD TO BE FULLY AT THE CUSTOMER'S RISK.

In order to minimize risks associated with the customer's applications, adequate design and operating safeguards must be provided by the customer to minimize inherent or procedural hazards.

TI assumes no liability for applications assistance or customer product design. TI does not warrant or represent that any license, either express or implied, is granted under any patent right, copyright, mask work right, or other intellectual property right of TI covering or relating to any combination, machine, or process in which such semiconductor products or services might be or are used. TI's publication of information regarding any third party's products or services does not constitute TI's approval, warranty or endorsement thereof.