

SN54ABT16652, SN74ABT16652 16-BIT BUS TRANSCEIVERS AND REGISTERS WITH 3-STATE OUTPUTS

SCBS215B – FEBRUARY 1991 – REVISED JANUARY 1997

- **Members of the Texas Instruments Widebus™ Family**
- **State-of-the-Art EPIC-II B™ BiCMOS Design Significantly Reduces Power Dissipation**
- **Latch-Up Performance Exceeds 500 mA Per JEDEC Standard JESD-17**
- **Typical V_{OLP} (Output Ground Bounce) < 1 V at $V_{CC} = 5 V, T_A = 25^\circ C$**
- **Distributed V_{CC} and GND Pin Configuration Minimizes High-Speed Switching Noise**
- **Flow-Through Architecture Optimizes PCB Layout**
- **High-Drive Outputs ($-32\text{-mA } I_{OH}, 64\text{-mA } I_{OL}$)**
- **Package Options Include Plastic 300-mil Shrink Small-Outline (DL) Package and 380-mil Fine-Pitch Ceramic Flat (WD) Package Using 25-mil Center-to-Center Spacings**

SN54ABT16652 . . . WD PACKAGE
SN74ABT16652 . . . DL PACKAGE
(TOP VIEW)

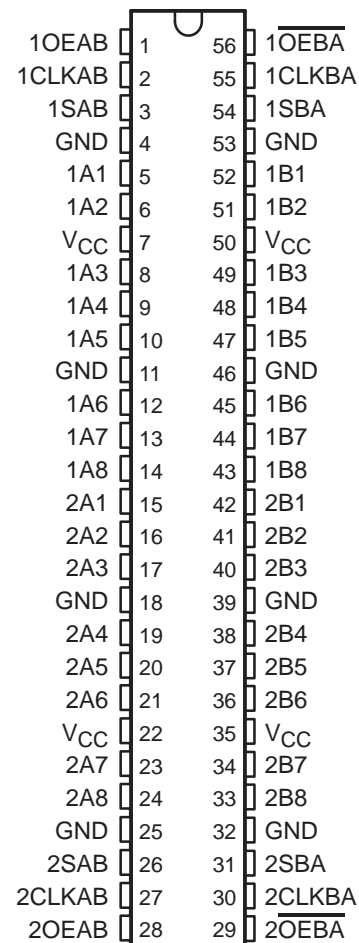

description

The 'ABT16652 are 16-bit bus transceivers that consist of D-type flip-flops and control circuitry arranged for multiplexed transmission of data directly from the data bus or from the internal storage registers. These devices can be used as two 8-bit transceivers or one 16-bit transceiver.

Output-enable (OEAB and \overline{OEBA}) inputs are provided to control the transceiver functions. Select-control (SAB and SBA) inputs are provided to select whether real-time or stored data is transferred. The circuitry used for select control eliminates the typical decoding glitch that occurs in a multiplexer during the transition between stored and real-time data. A low input selects real-time data, and a high input selects stored data. Figure 1 illustrates the four fundamental bus-management functions that can be performed with the 'ABT16652.

Data on the A- or B-data bus, or both, can be stored in the internal D-type flip-flops by low-to-high transitions at the appropriate clock (CLKAB or CLKBA) inputs regardless of the select- or enable-control inputs. When SAB and SBA are in the real-time transfer mode, it is possible to store data without using the internal D-type flip-flops by simultaneously enabling OEAB and \overline{OEBA} . In this configuration, each output reinforces its input. When all other data sources to the two sets of bus lines are at high impedance, each set of bus lines remains at its last state.



Please be aware that an important notice concerning availability, standard warranty, and use in critical applications of Texas Instruments semiconductor products and disclaimers thereto appears at the end of this data sheet.

Widebus and EPIC-II B are trademarks of Texas Instruments Incorporated.

PRODUCTION DATA information is current as of publication date. Products conform to specifications per the terms of Texas Instruments standard warranty. Production processing does not necessarily include testing of all parameters.

 **TEXAS
INSTRUMENTS**

POST OFFICE BOX 655303 • DALLAS, TEXAS 75265

Copyright © 1997, Texas Instruments Incorporated

SN54ABT16652, SN74ABT16652 16-BIT BUS TRANSCEIVERS AND REGISTERS WITH 3-STATE OUTPUTS

SCBS215B – FEBRUARY 1991 – REVISED JANUARY 1997

description (continued)

To ensure the high-impedance state during power up or power down, \overline{OEBA} should be tied to V_{CC} through a pullup resistor; the minimum value of the resistor is determined by the current-sinking capability of the driver (B to A). OEAB should be tied to GND through a pulldown resistor; the minimum value of the resistor is determined by the current-sourcing capability of the driver (A to B).

The SN54ABT16652 is characterized for operation over the full military temperature range of -55°C to 125°C . The SN74ABT16652 is characterized for operation from -40°C to 85°C .

FUNCTION TABLE

INPUTS						DATA I/O†		OPERATION OR FUNCTION
OEAB	\overline{OEBA}	CLKAB	CLKBA	SAB	SBA	A1–A8	B1–B8	
L	H	H or L	H or L	X	X	Input	Input	Isolation
L	H	↑	↑	X	X	Input	Input	Store A and B data
X	H	↑	H or L	X	X	Input	Unspecified‡	Store A, hold B
H	H	↑	↑	X‡	X	Input	Output	Store A in both registers
L	X	H or L	↑	X	X	Unspecified‡	Input	Hold A, store B
L	L	↑	↑	X	X‡	Output	Input	Store B in both registers
L	L	X	X	X	L	Output	Input	Real-time B data to A bus
L	L	X	H or L	X	H	Output	Input	Stored B data to A bus
H	H	X	X	L	X	Input	Output	Real-time A data to B bus
H	H	H or L	X	H	X	Input	Output	Stored A data to B bus
H	L	H or L	H or L	H	H	Output	Output	Stored A data to B bus and stored B data to A bus

† The data-output functions may be enabled or disabled by a variety of level combinations at OEAB or \overline{OEBA} . Data-input functions are always enabled; i.e., data at the bus terminals is stored on every low-to-high transition of the clock inputs.

‡ Select control = L; clocks can occur simultaneously.

Select control = H; clocks must be staggered to load both registers.

SN54ABT16652, SN74ABT16652
 16-BIT BUS TRANSCEIVERS AND REGISTERS
 WITH 3-STATE OUTPUTS

SCBS215B – FEBRUARY 1991 – REVISED JANUARY 1997

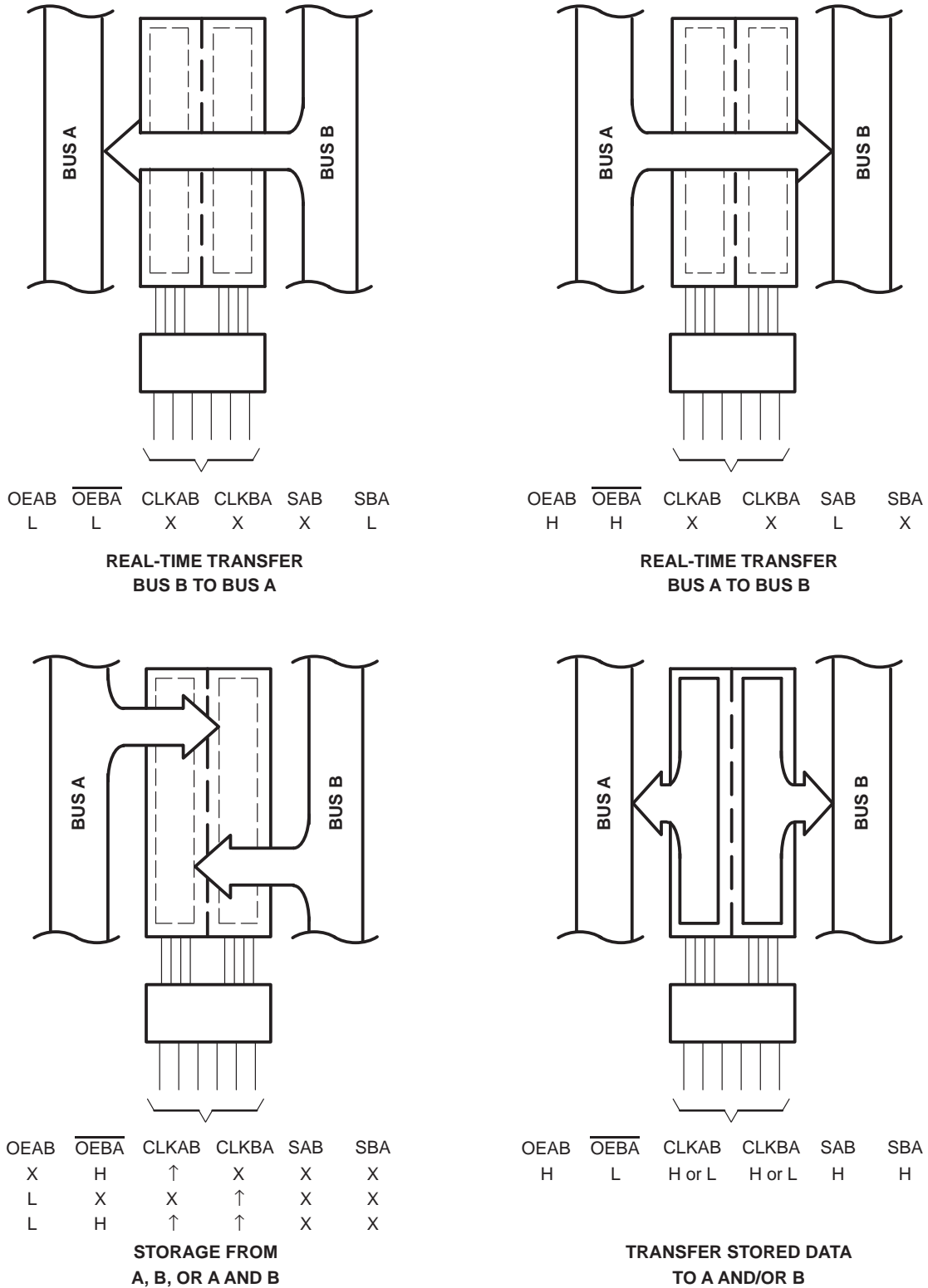
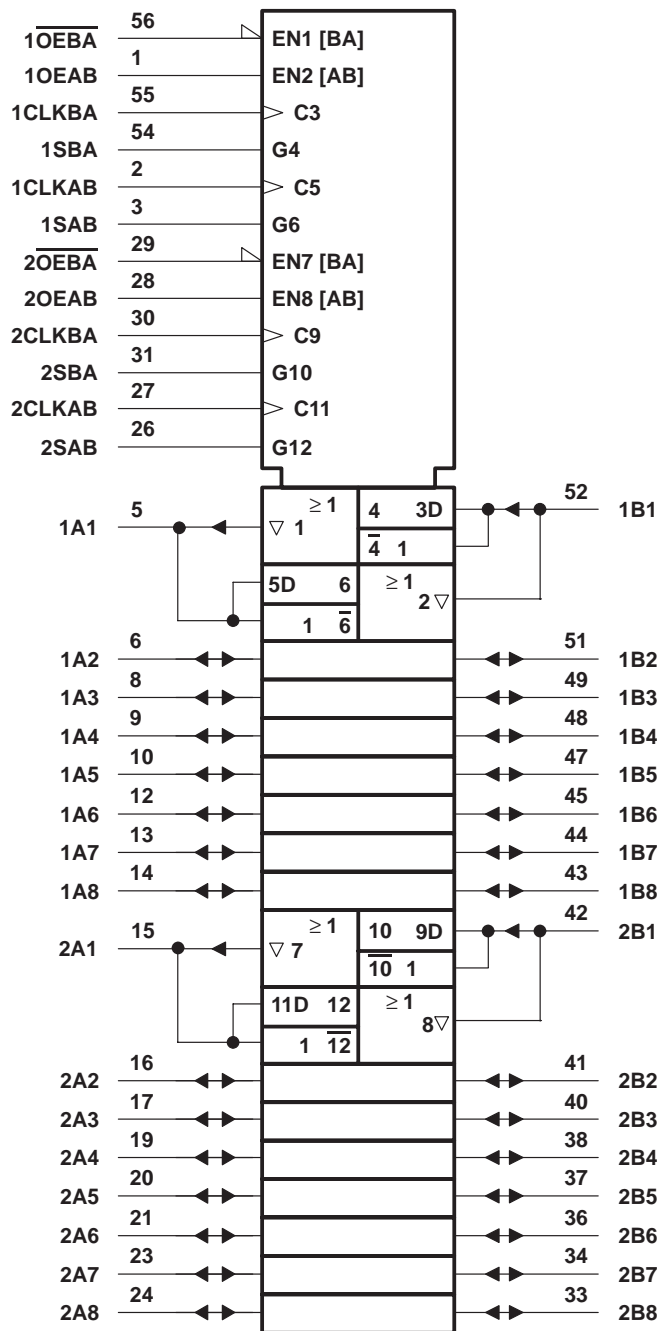

Figure 1. Bus-Management Functions

SN54ABT16652, SN74ABT16652 16-BIT BUS TRANSCEIVERS AND REGISTERS WITH 3-STATE OUTPUTS

SCBS215B – FEBRUARY 1991 – REVISED JANUARY 1997

logic symbol†



† This symbol is in accordance with ANSI/IEEE Std 91-1984 and IEC Publication 617-12.



SN54ABT16652, SN74ABT16652
 16-BIT BUS TRANSCEIVERS AND REGISTERS
 WITH 3-STATE OUTPUTS

SCBS215B – FEBRUARY 1991 – REVISED JANUARY 1997

logic diagram (positive logic)

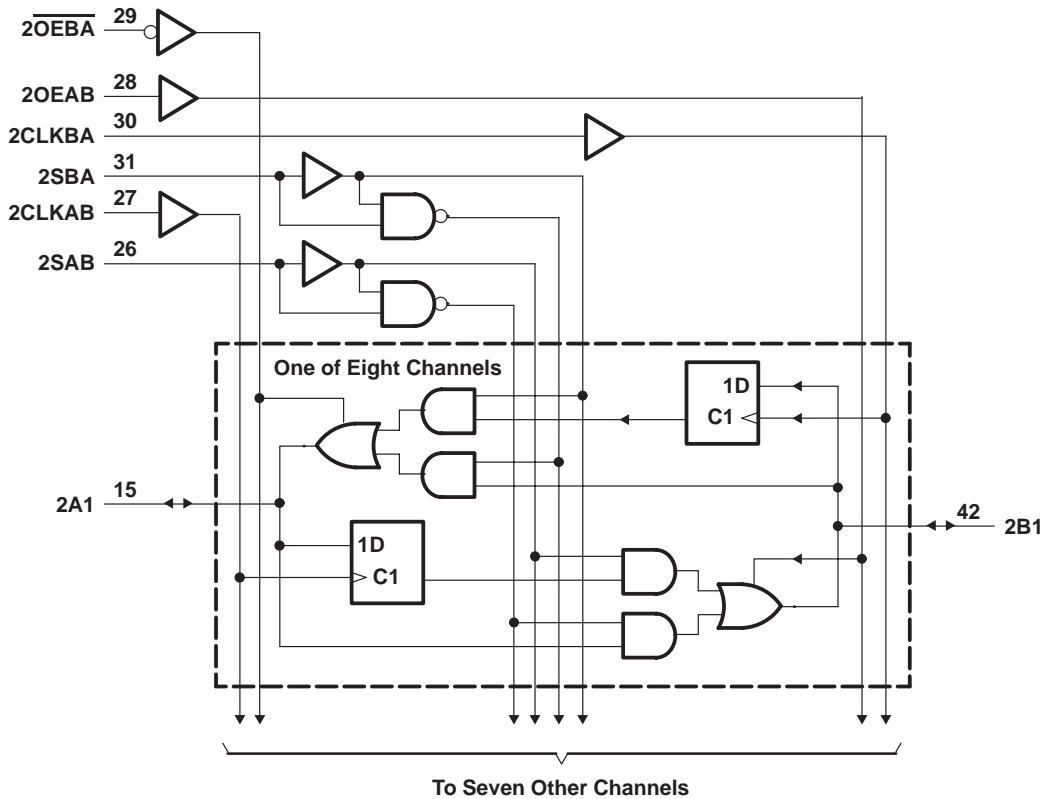
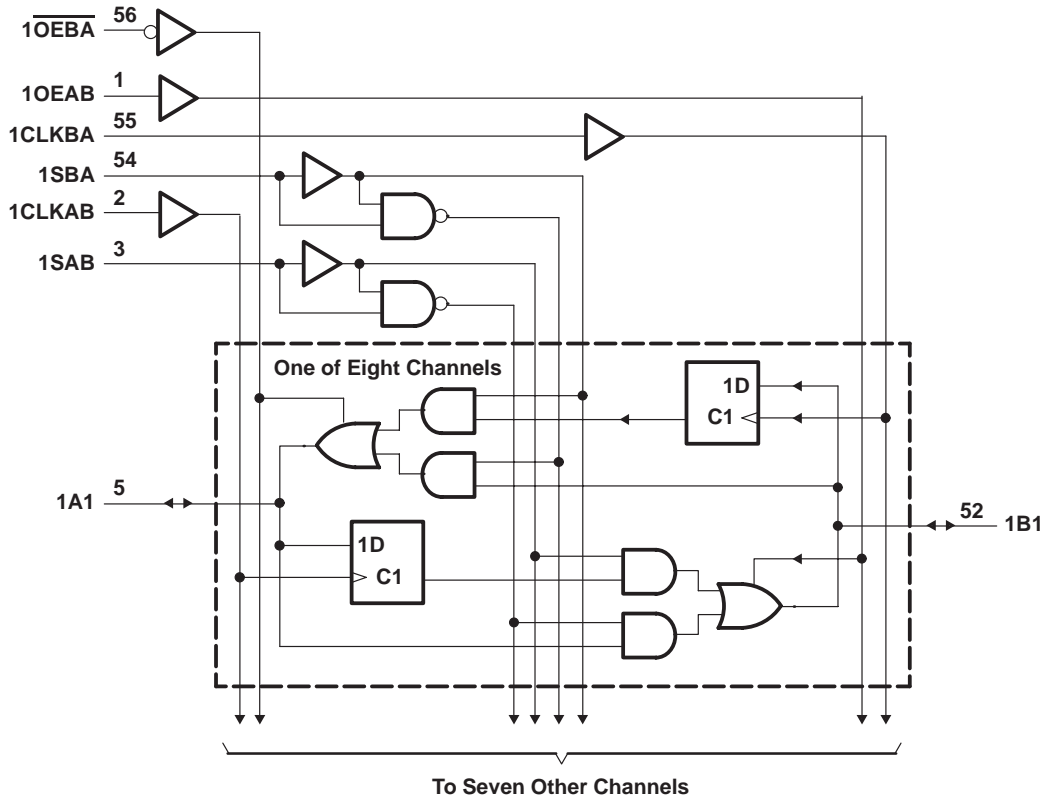

SN54ABT16652, SN74ABT16652 16-BIT BUS TRANSCEIVERS AND REGISTERS WITH 3-STATE OUTPUTS

SCBS215B – FEBRUARY 1991 – REVISED JANUARY 1997

absolute maximum ratings over operating free-air temperature range (unless otherwise noted)†

Supply voltage range, V_{CC}	-0.5 V to 7 V
Input voltage range, V_I (except I/O ports) (see Note 1)	-0.5 V to 7 V
Voltage range applied to any output in the high or power-off state, V_O	-0.5 V to 5.5 V
Current into any output in the low state, I_O : SN54ABT16652	96 mA
SN74ABT16652	128 mA
Input clamp current, I_{IK} ($V_I < 0$)	-18 mA
Output clamp current, I_{OK} ($V_O < 0$)	-50 mA
Package thermal impedance, θ_{JA} (see Note 2): DL package	74°C/W
Storage temperature range, T_{stg}	-65°C to 150°C

† Stresses beyond those listed under “absolute maximum ratings” may cause permanent damage to the device. These are stress ratings only, and functional operation of the device at these or any other conditions beyond those indicated under “recommended operating conditions” is not implied. Exposure to absolute-maximum-rated conditions for extended periods may affect device reliability.

- NOTES: 1. The input and output negative-voltage ratings may be exceeded if the input and output clamp-current ratings are observed.
2. The package thermal impedance is calculated in accordance with EIA/JEDEC Std JESD51.

recommended operating conditions (see Note 3)

		SN54ABT16652		SN74ABT16652		UNIT
		MIN	MAX	MIN	MAX	
V_{CC}	Supply voltage	4.5	5.5	4.5	5.5	V
V_{IH}	High-level input voltage	2		2		V
V_{IL}	Low-level input voltage		0.8		0.8	V
V_I	Input voltage	0	V_{CC}	0	V_{CC}	V
I_{OH}	High-level output current		-24		-32	mA
I_{OL}	Low-level output current		48		64	mA
$\Delta t/\Delta v$	Input transition rise or fall rate	Outputs enabled		10	10	ns/V
T_A	Operating free-air temperature	-55	125	-40	85	°C

NOTE 3: Unused pins (input or I/O) must be held high or low to prevent them from floating.



SN54ABT16652, SN74ABT16652 16-BIT BUS TRANSCEIVERS AND REGISTERS WITH 3-STATE OUTPUTS

SCBS215B – FEBRUARY 1991 – REVISED JANUARY 1997

electrical characteristics over recommended operating free-air temperature range (unless otherwise noted)

PARAMETER	TEST CONDITIONS	T _A = 25°C			SN54ABT16652		SN74ABT16652		UNIT	
		MIN	TYP†	MAX	MIN	MAX	MIN	MAX		
V _{IK}	V _{CC} = 4.5 V, I _I = -18 mA			-1.2		-1.2		-1.2	V	
V _{OH}	V _{CC} = 4.5 V, I _{OH} = -3 mA			2.5		2.5		2.5	V	
	V _{CC} = 5 V, I _{OH} = -3 mA			3		3		3		
	V _{CC} = 4.5 V, I _{OH} = -24 mA I _{OH} = -32 mA			2 2*		2		2		
V _{OL}	V _{CC} = 4.5 V					0.55		0.55	V	
						0.55*		0.55		
V _{hys}				100					mV	
I _I	Control inputs A or B ports	V _{CC} = 5.5 V, V _I = V _{CC} or GND					±1		±1	μA
							±20		±20	
I _{OZH} ‡	V _{CC} = 5.5 V, V _O = 2.7 V			10		10		10	μA	
I _{OZL} ‡	V _{CC} = 5.5 V, V _O = 0.5 V			-10		-10		-10	μA	
I _{off}	V _{CC} = 0, V _I or V _O ≤ 4.5 V			±100				±100	μA	
I _{CEX}	V _{CC} = 5.5 V, V _O = 5.5 V	Outputs high		50		50		50	μA	
I _O §	V _{CC} = 5.5 V, V _O = 2.5 V			-50	-100	-180		-50	-180	mA
I _{CC}	A or B ports	V _{CC} = 5.5 V, I _O = 0, V _I = V _{CC} or GND	Outputs high			2		2	2	mA
			Outputs low			32		32	32	
			Outputs disabled			2		2	2	
ΔI _{CC} ¶	Data inputs	V _{CC} = 5.5 V, One input at 3.4 V, Other inputs at V _{CC} or GND	Outputs enabled			50		50	50	μA
			Outputs disabled			50		50	50	
	Control inputs			V _{CC} = 5.5 V, One input at 3.4 V, Other inputs at V _{CC} or GND			50		50	
C _i	Control inputs	V _I = 2.5 V or 0.5 V			4				pF	
C _{io}	A or B ports	V _O = 2.5 V or 0.5 V			8				pF	

* On products compliant to MIL-PRF-38535, this parameter does not apply.

† All typical values are at V_{CC} = 5 V.

‡ The parameters I_{OZH} and I_{OZL} include the input leakage current.

§ Not more than one output should be tested at a time, and the duration of the test should not exceed one second.

¶ This is the increase in supply current for each input that is at the specified TTL voltage level rather than V_{CC} or GND.



SN54ABT16652, SN74ABT16652
16-BIT BUS TRANSCEIVERS AND REGISTERS
WITH 3-STATE OUTPUTS

SCBS215B – FEBRUARY 1991 – REVISED JANUARY 1997

timing requirements over recommended ranges of supply voltage and operating free-air temperature (unless otherwise noted) (see Figure 2)

	SN54ABT16652				UNIT
	V _{CC} = 5 V, T _A = 25°C		MIN	MAX	
	MIN	MAX			
f _{clock} Clock frequency	0	125	0	125	MHz
t _w Pulse duration, CLK high or low	4.3		4.3		ns
t _{su} Setup time, A or B before CLKAB↑ or CLKBA↑	3.5		4		ns
t _h Hold time, A or B after CLKAB↑ or CLKBA↑	0.5		0.5		ns

timing requirements over recommended ranges of supply voltage and operating free-air temperature (unless otherwise noted) (see Figure 2)

	SN74ABT16652				UNIT
	V _{CC} = 5 V, T _A = 25°C		MIN	MAX	
	MIN	MAX			
f _{clock} Clock frequency	0	125	0	125	MHz
t _w Pulse duration, CLK high or low	4.3		4.3		ns
t _{su} Setup time, A or B before CLKAB↑ or CLKBA↑	3		3		ns
t _h Hold time, A or B after CLKAB↑ or CLKBA↑	0		0		ns



SN54ABT16652, SN74ABT16652 16-BIT BUS TRANSCEIVERS AND REGISTERS WITH 3-STATE OUTPUTS

SCBS215B – FEBRUARY 1991 – REVISED JANUARY 1997

switching characteristics over recommended ranges of supply voltage and operating free-air temperature, $C_L = 50$ pF (unless otherwise noted) (see Figure 2)

PARAMETER	FROM (INPUT)	TO (OUTPUT)	SN54ABT16652				UNIT	
			$V_{CC} = 5$ V, $T_A = 25^\circ\text{C}$			MIN		MAX
			MIN	TYP	MAX			
f_{max}			125			125	MHz	
t_{PLH}	CLK	B or A	1.5	3.1	4	1	5	ns
t_{PHL}			1.5	3.2	4.1	1	5	
t_{PLH}	A or B	B or A	1	2.3	3.2	0.6	4	ns
t_{PHL}			1	3	4.1	0.6	4.9	
t_{PLH}	SAB or SBA†	B or A	1	2.9	4.3	0.6	5.3	ns
t_{PHL}			1	3.1	4.6	0.6	5.3	
t_{PZH}	\overline{OEBA}	A	1	2.8	4.1	0.6	5.2	ns
t_{PZL}			1.5	3.1	4.4	1	5.4	
t_{PHZ}	\overline{OEBA}	A	1.5	3.4	4.7	0.8	5.3	ns
t_{PLZ}			1.5	2.7	4	1	5.3	
t_{PZH}	OEAB	B	1	2.6	3.6	0.8	4.7	ns
t_{PZL}			1.5	2.8	4.5	1	5	
t_{PHZ}	OEAB	B	2	4.2	5.9	1	6.4	ns
t_{PLZ}			1.5	3.4	4.9	1	5.9	

† These parameters are measured with the internal output state of the storage register opposite that of the bus input.

switching characteristics over recommended ranges of supply voltage and operating free-air temperature, $C_L = 50$ pF (unless otherwise noted) (see Figure 2)

PARAMETER	FROM (INPUT)	TO (OUTPUT)	SN74ABT16652				UNIT	
			$V_{CC} = 5$ V, $T_A = 25^\circ\text{C}$			MIN		MAX
			MIN	TYP	MAX			
f_{max}			125			125	MHz	
t_{PLH}	CLK	B or A	1.5	3.1	4	1.5	4.9	ns
t_{PHL}			1.5	3.2	4.1	1.5	4.7	
t_{PLH}	A or B	B or A	1	2.3	3.2	1	3.9	ns
t_{PHL}			1	3	4.1	1	4.6	
t_{PLH}	SAB or SBA†	B or A	1	2.9	4.3	1	5	ns
t_{PHL}			1	3.1	4.3	1	5	
t_{PZH}	\overline{OEBA}	A	1	2.8	4.1	1	5	ns
t_{PZL}			1.5	3.1	4.4	1.5	5.3	
t_{PHZ}	\overline{OEBA}	A	1.5	3.4	4.4	1.5	4.9	ns
t_{PLZ}			1.5	2.7	3.6	1.5	4	
t_{PZH}	OEAB	B	1	2.6	3.6	1	4.2	ns
t_{PZL}			1.5	2.8	3.9	1.5	4.6	
t_{PHZ}	OEAB	B	2	4.2	5.5	2	5.9	ns
t_{PLZ}			1.5	3.4	4.5	1.5	5.2	

† These parameters are measured with the internal output state of the storage register opposite that of the bus input.



SN54ABT16652, SN74ABT16652 16-BIT BUS TRANSCEIVERS AND REGISTERS WITH 3-STATE OUTPUTS

SCBS215B – FEBRUARY 1991 – REVISED JANUARY 1997

PARAMETER MEASUREMENT INFORMATION

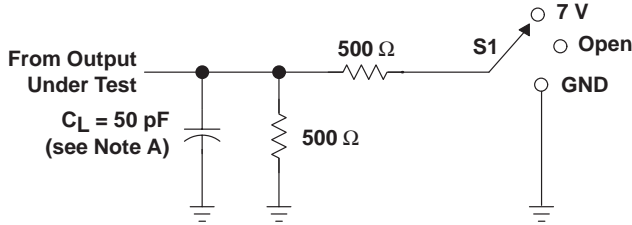

LOAD CIRCUIT

TEST	S1
t_{PLH}/t_{PHL}	Open
t_{PLZ}/t_{PZL}	7 V
t_{PHZ}/t_{PZH}	Open

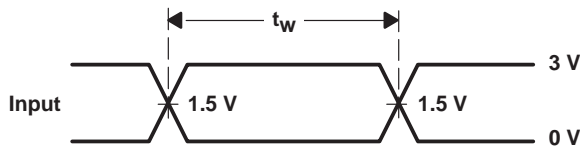

VOLTAGE WAVEFORMS
PULSE DURATION

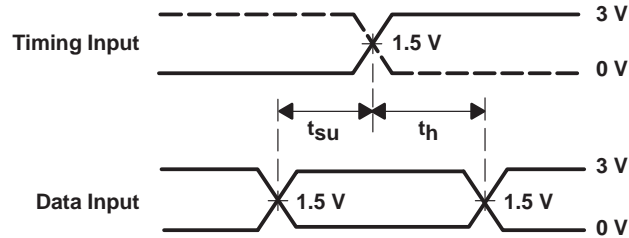

VOLTAGE WAVEFORMS
SETUP AND HOLD TIMES

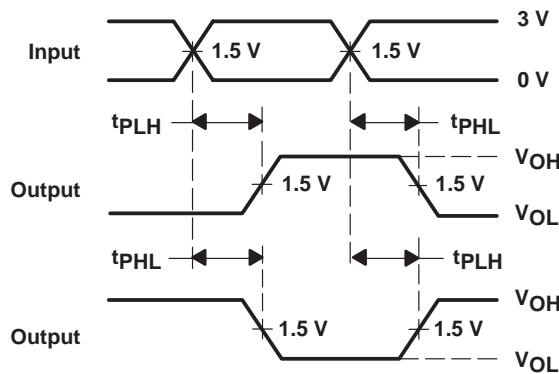

VOLTAGE WAVEFORMS
PROPAGATION DELAY TIMES
INVERTING AND NONINVERTING OUTPUTS

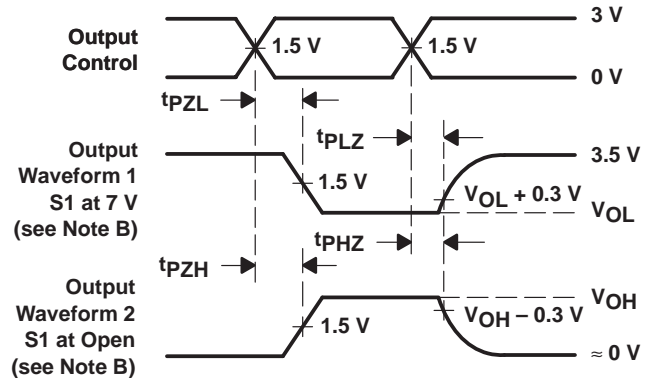

VOLTAGE WAVEFORMS
ENABLE AND DISABLE TIMES
LOW- AND HIGH-LEVEL ENABLING

- NOTES: A. C_L includes probe and jig capacitance.
 B. Waveform 1 is for an output with internal conditions such that the output is low except when disabled by the output control. Waveform 2 is for an output with internal conditions such that the output is high except when disabled by the output control.
 C. All input pulses are supplied by generators having the following characteristics: $PRR \leq 10 \text{ MHz}$, $Z_O = 50 \Omega$, $t_r \leq 2.5 \text{ ns}$, $t_f \leq 2.5 \text{ ns}$.
 D. The outputs are measured one at a time with one transition per measurement.

Figure 2. Load Circuit and Voltage Waveforms

IMPORTANT NOTICE

Texas Instruments and its subsidiaries (TI) reserve the right to make changes to their products or to discontinue any product or service without notice, and advise customers to obtain the latest version of relevant information to verify, before placing orders, that information being relied on is current and complete. All products are sold subject to the terms and conditions of sale supplied at the time of order acknowledgement, including those pertaining to warranty, patent infringement, and limitation of liability.

TI warrants performance of its semiconductor products to the specifications applicable at the time of sale in accordance with TI's standard warranty. Testing and other quality control techniques are utilized to the extent TI deems necessary to support this warranty. Specific testing of all parameters of each device is not necessarily performed, except those mandated by government requirements.

CERTAIN APPLICATIONS USING SEMICONDUCTOR PRODUCTS MAY INVOLVE POTENTIAL RISKS OF DEATH, PERSONAL INJURY, OR SEVERE PROPERTY OR ENVIRONMENTAL DAMAGE ("CRITICAL APPLICATIONS"). TI SEMICONDUCTOR PRODUCTS ARE NOT DESIGNED, AUTHORIZED, OR WARRANTED TO BE SUITABLE FOR USE IN LIFE-SUPPORT DEVICES OR SYSTEMS OR OTHER CRITICAL APPLICATIONS. INCLUSION OF TI PRODUCTS IN SUCH APPLICATIONS IS UNDERSTOOD TO BE FULLY AT THE CUSTOMER'S RISK.

In order to minimize risks associated with the customer's applications, adequate design and operating safeguards must be provided by the customer to minimize inherent or procedural hazards.

TI assumes no liability for applications assistance or customer product design. TI does not warrant or represent that any license, either express or implied, is granted under any patent right, copyright, mask work right, or other intellectual property right of TI covering or relating to any combination, machine, or process in which such semiconductor products or services might be or are used. TI's publication of information regarding any third party's products or services does not constitute TI's approval, warranty or endorsement thereof.