

SN54ABT16500B, SN74ABT16500B 18-BIT UNIVERSAL BUS TRANSCEIVERS WITH 3-STATE OUTPUTS

SCBS057G – DECEMBER 1990 – REVISED MAY 1997

- **Members of the Texas Instruments Widebus™ Family**
- **State-of-the-Art EPIC-IIB™ BiCMOS Design Significantly Reduces Power Dissipation**
- **UBT™ (Universal Bus Transceiver) Combines D-Type Latches and D-Type Flip-Flops for Operation in Transparent, Latched, or Clocked Mode**
- **ESD Protection Exceeds 2000 V Per MIL-STD-883, Method 3015**
- **Latch-Up Performance Exceeds 500 mA Per JEDEC Standard JESD-17**
- **Typical V_{OLP} (Output Ground Bounce) < 0.8 V at $V_{CC} = 5 V$, $T_A = 25^\circ C$**
- **High-Impedance State During Power Up and Power Down**
- **Flow-Through Architecture Optimizes PCB Layout**
- **Package Options Include Plastic 300-mil Shrink Small-Outline (DL) and Thin Shrink Small-Outline (DGG) Packages and 380-mil Fine-Pitch Ceramic Flat (WD) Package Using 25-mil Center-to-Center Spacings**

SN54ABT16500B . . . WD PACKAGE
SN74ABT16500B . . . DGG OR DL PACKAGE
(TOP VIEW)

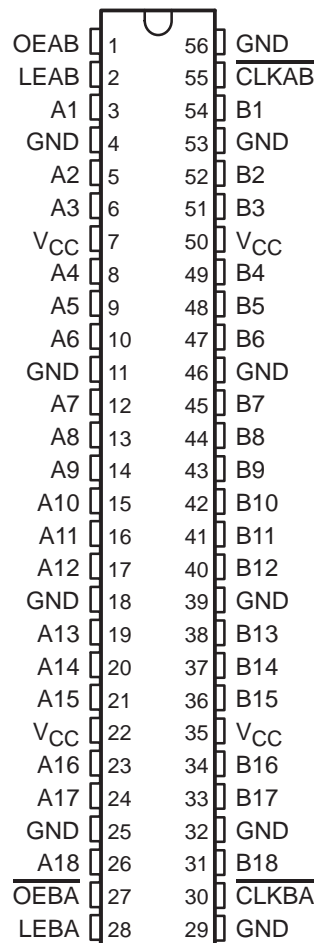

description

These 18-bit universal bus transceivers combine D-type latches and D-type flip-flops to allow data flow in transparent, latched, and clocked modes.

Data flow in each direction is controlled by output-enable (OEAB and OEBA), latch-enable (LEAB and LEBA), and clock (CLKAB and CLKBA) inputs. For A-to-B data flow, the device operates in the transparent mode when LEAB is high. When LEAB is low, the A data is latched if CLKAB is held at a high or low logic level. If LEAB is low, the A data is stored in the latch/flip-flop on the high-to-low transition of CLKAB. OEAB is active-high. When OEAB is high, the outputs are active. When OEAB is low, the outputs are in the high-impedance state.

Data flow for B to A is similar to that of A to B but uses OEBA, LEBA, and CLKBA. The output enables are complementary (OEAB is active high and OEBA is active low).



Please be aware that an important notice concerning availability, standard warranty, and use in critical applications of Texas Instruments semiconductor products and disclaimers thereto appears at the end of this data sheet.

Widebus, EPIC-IIB, and UBT are trademarks of Texas Instruments Incorporated.

UNLESS OTHERWISE NOTED this document contains PRODUCTION DATA information current as of publication date. Products conform to specifications per the terms of Texas Instruments standard warranty. Production processing does not necessarily include testing of all parameters.

 **TEXAS
INSTRUMENTS**

POST OFFICE BOX 655303 • DALLAS, TEXAS 75265

Copyright © 1997, Texas Instruments Incorporated

SN54ABT16500B, SN74ABT16500B
18-BIT UNIVERSAL BUS TRANSCEIVERS
WITH 3-STATE OUTPUTS

SCBS057G – DECEMBER 1990 – REVISED MAY 1997

description (continued)

When V_{CC} is between 0 and 2.1 V, the device is in the high-impedance state during power up or power down. However, to ensure the high-impedance state above 2.1 V, \overline{OE} should be tied to V_{CC} through a pullup resistor and OE should be tied to GND through a pulldown resistor; the minimum value of the resistor is determined by the current-sinking/current-sourcing capability of the driver.

The SN54ABT16500B is characterized for operation over the full military temperature range of -55°C to 125°C . The SN74ABT16500B is characterized for operation from -40°C to 85°C .

FUNCTION TABLE†

INPUTS				OUTPUT
OEAB	LEAB	CLKAB	A	B
L	X	X	X	Z
H	H	X	L	L
H	H	X	H	H
H	L	↓	L	L
H	L	↓	H	H
H	L	H	X	B_0^{\ddagger}
H	L	L	X	B_0^{\S}

† A-to-B data flow is shown: B-to-A flow is similar but uses \overline{OEBA} , \overline{LEBA} , and \overline{CLKBA} .

‡ Output level before the indicated steady-state input conditions were established

§ Output level before the indicated steady-state input conditions were established, provided that CLKAB was low before LEAB went low



SN54ABT16500B, SN74ABT16500B 18-BIT UNIVERSAL BUS TRANSCEIVERS WITH 3-STATE OUTPUTS

SCBS057G – DECEMBER 1990 – REVISED MAY 1997

logic symbol†

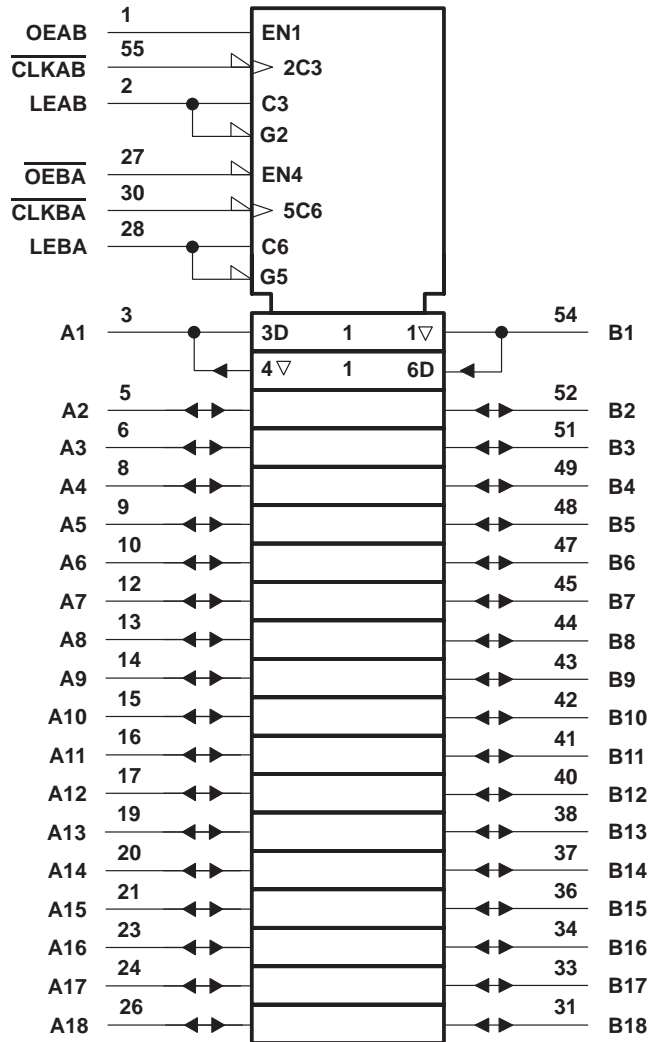

† This symbol is in accordance with ANSI/IEEE Std 91-1984 and IEC Publication 617-12.

SN54ABT16500B, SN74ABT16500B
18-BIT UNIVERSAL BUS TRANSCEIVERS
WITH 3-STATE OUTPUTS

SCBS057G – DECEMBER 1990 – REVISED MAY 1997

logic diagram (positive logic)

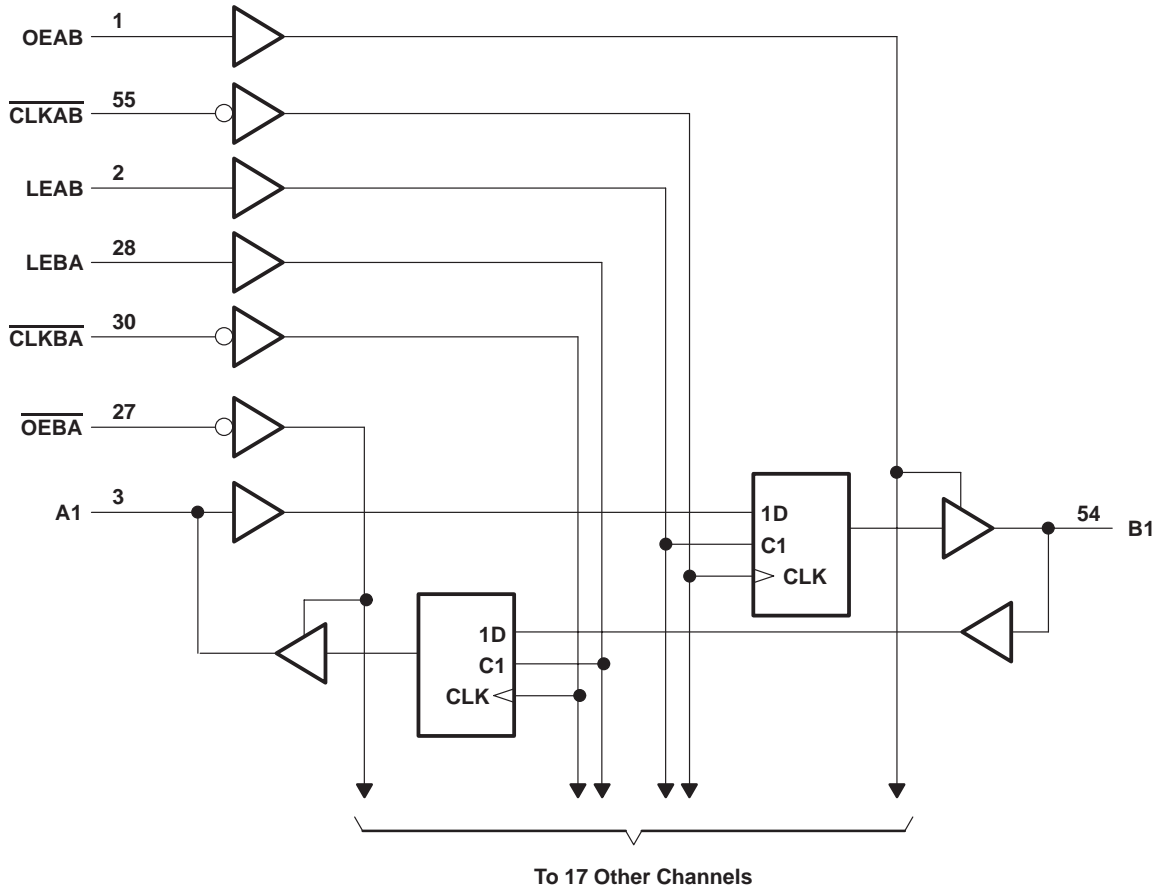

absolute maximum ratings over operating free-air temperature range (unless otherwise noted)†

Supply voltage range, V_{CC}	-0.5 V to 7 V
Input voltage range, V_I (except I/O ports) (see Note 1)	-0.5 V to 7 V
Voltage range applied to any output in the high or power-off state, V_O	-0.5 V to 5.5 V
Current into any output in the low state, I_O : SN54ABT16500B	96 mA
SN74ABT16500B	128 mA
Input clamp current, I_{IK} ($V_I < 0$)	-18 mA
Output clamp current, I_{OK} ($V_O < 0$)	-50 mA
Package thermal impedance, θ_{JA} (see Note 2): DGG package	81°C/W
DL package	74°C/W
Storage temperature range, T_{stg}	-65°C to 150°C

† Stresses beyond those listed under “absolute maximum ratings” may cause permanent damage to the device. These are stress ratings only, and functional operation of the device at these or any other conditions beyond those indicated under “recommended operating conditions” is not implied. Exposure to absolute-maximum-rated conditions for extended periods may affect device reliability.

- NOTES: 1. The input and output negative-voltage ratings may be exceeded if the input and output clamp-current ratings are observed.
 2. The package thermal impedance is calculated in accordance with EIA/JEDEC Std JESD51.



SN54ABT16500B, SN74ABT16500B 18-BIT UNIVERSAL BUS TRANSCEIVERS WITH 3-STATE OUTPUTS

SCBS057G – DECEMBER 1990 – REVISED MAY 1997

recommended operating conditions (see Note 3)

		SN54ABT16500B		SN74ABT16500B		UNIT
		MIN	MAX	MIN	MAX	
V _{CC}	Supply voltage	4.5	5.5	4.5	5.5	V
V _{IH}	High-level input voltage	2		2		V
V _{IL}	Low-level input voltage		0.8		0.8	V
V _I	Input voltage	0	V _{CC}	0	V _{CC}	V
I _{OH}	High-level output current		-24		-32	mA
I _{OL}	Low-level output current		48		64	mA
Δt/Δv	Input transition rise or fall rate	Outputs enabled			10	ns/V
Δt/ΔV _{CC}	Power-up ramp rate	200		200		μs/V
T _A	Operating free-air temperature	-55	125	-40	85	°C

NOTE 3: Unused pins (input or I/O) must be held high or low to prevent them from floating.

PRODUCT PREVIEW information concerns products in the formative or design phase of development. Characteristic data and other specifications are design goals. Texas Instruments reserves the right to change or discontinue these products without notice.



POST OFFICE BOX 655303 • DALLAS, TEXAS 75265

SN54ABT16500B, SN74ABT16500B 18-BIT UNIVERSAL BUS TRANSCEIVERS WITH 3-STATE OUTPUTS

SCBS057G – DECEMBER 1990 – REVISED MAY 1997

electrical characteristics over recommended operating free-air temperature range (unless otherwise noted)

PARAMETER	TEST CONDITIONS	T _A = 25°C			SN54ABT16500B		SN74ABT16500B		UNIT
		MIN	TYP†	MAX	MIN	MAX	MIN	MAX	
V _{IK}	V _{CC} = 4.5 V, I _I = -18 mA			-1.2		-1.2		-1.2	V
V _{OH}	V _{CC} = 4.5 V, I _{OH} = -3 mA			2.5		2.5		2.5	V
	V _{CC} = 5 V, I _{OH} = -3 mA			3		3		3	
	V _{CC} = 4.5 V	I _{OH} = -24 mA			2		2		
I _{OH} = -32 mA				2*				2	
V _{OL}	V _{CC} = 4.5 V	I _{OL} = 48 mA				0.55			V
		I _{OL} = 64 mA				0.55*		0.55	
V _{hys}				100					mV
I _{off}	V _{CC} = 0, V _I or V _O ≤ 4.5 V					±100		±100	μA
I _{CEX}	V _{CC} = 5.5 V, V _O = 5.5 V	Outputs high				50		50	μA
I _I	Control inputs	V _{CC} = 0 to 5.5 V, V _I = V _{CC} or GND				±1		±1	μA
	A or B ports	V _{CC} = 2.1 V to 5.5 V, V _I = V _{CC} or GND				±20		±20	
I _{O‡}	V _{CC} = 5.5 V, V _O = 2.5 V			-50 -100 -180		-50 -180		-50 -180	mA
I _{OZPU§}	V _{CC} = 0 to 2.1 V, V _O = 0.5 V to 2.7 V, \overline{OE} or OE = X					±50		±50	μA
I _{OZPD§}	V _{CC} = 2.1 V to 0, V _O = 0.5 V to 2.7 V, \overline{OE} or OE = X					±50		±50	μA
I _{OZH¶}	V _{CC} = 2.1 V to 5.5 V, V _O = 2.7 V, $\overline{OE} \geq 2$ V, OE ≤ 0.8 V#					10		10	μA
I _{OZL¶}	V _{CC} = 2.1 V to 5.5 V, V _O = 0.5 V, $\overline{OE} \geq 2$ V, OE ≤ 0.8 V#					-10		-10	μA
I _{CC}	A or B ports	V _{CC} = 5.5 V, I _O = 0, V _I = V _{CC} or GND	Outputs high			3		3	mA
		Outputs low			36		36		
		Outputs disabled			3		3		
ΔI _{CC}	V _{CC} = 5.5 V, One input at 3.4 V, Other inputs at V _{CC} or GND					50		50	μA
C _i	Control inputs	V _I = 2.5 V or 0.5 V				3			pF
C _{iO}	A or B ports	V _O = 2.5 V or 0.5 V				9			pF

* On products compliant to MIL-PRF-38535, this parameter does not apply.

† All typical values are at V_{CC} = 5 V.

‡ Not more than one output should be tested at a time, and the duration of the test should not exceed one second.

§ This parameter is characterized, but not production tested.

¶ The parameters I_{OZH} and I_{OZL} include the input leakage current.

For V_{CC} between 2.1 V and 4 V, OE should be less than or equal to 0.5 V to ensure a low state.

|| This is the increase in supply current for each input that is at the specified TTL voltage level rather than V_{CC} or GND.

PRODUCT PREVIEW information concerns products in the formative or design phase of development. Characteristic data and other specifications are design goals. Texas Instruments reserves the right to change or discontinue these products without notice.



SN54ABT16500B, SN74ABT16500B 18-BIT UNIVERSAL BUS TRANSCEIVERS WITH 3-STATE OUTPUTS

SCBS057G – DECEMBER 1990 – REVISED MAY 1997

timing requirements over recommended ranges of supply voltage and operating free-air temperature (unless otherwise noted) (see Figure 1)

		SN54ABT16500B		SN74ABT16500B		UNIT
		MIN	MAX	MIN	MAX	
f_{clock}	Clock frequency	0	150	0	150	MHz
t_w^\dagger	Pulse duration	LEAB or LEBA high		2.5		ns
		$\overline{\text{CLKAB}}$ or $\overline{\text{CLKBA}}$ high or low		3		
t_{su}	Setup time	A before $\overline{\text{CLKAB}}\downarrow$		3		ns
		B before $\overline{\text{CLKBA}}\downarrow$		3		
		A before LEAB \downarrow or B before LEBA \downarrow	$\overline{\text{CLK}}$ high	1		
			$\overline{\text{CLK}}$ low	2.5		
t_h	Hold time	A after $\overline{\text{CLKAB}}\downarrow$ or B after $\overline{\text{CLKBA}}\downarrow$		0		ns
		A after LEAB \downarrow or B after LEBA \downarrow		2		

† This parameter is characterized, but not production tested.

switching characteristics over recommended ranges of supply voltage and operating free-air temperature, $C_L = 50$ pF (unless otherwise noted) (see Figure 1)

PARAMETER	FROM (INPUT)	TO (OUTPUT)	$V_{CC} = 5$ V, $T_A = 25^\circ\text{C}$			SN54ABT16500B		SN74ABT16500B		UNIT
			MIN	TYP	MAX	MIN	MAX	MIN	MAX	
f_{max}			150	200		150		150	MHz	
t_{PLH}	A or B	B or A	1	2.5	3.6	1	4.2	1	4	ns
t_{PHL}			1	3.2	4.5	1	5.1	1	4.9	
t_{PLH}	LEAB or LEBA	B or A	1	3.2	4.5	1	5.6	1	5	ns
t_{PHL}			1	3.4	4.5	1	5.4	1	5	
t_{PLH}	$\overline{\text{CLKAB}}$ or $\overline{\text{CLKBA}}$	B or A	1	3.5	4.7	1	5.4	1	5.3	ns
t_{PHL}			1	3.5	4.7	1	5.4	1	5.3	
t_{PZH}	OEAB or $\overline{\text{OEBA}}$	B or A	1	3.4	4.6	1	5.3	1	5.1	ns
t_{PZL}			1.5	3.8	4.7	1.5	5.6	1.5	5.4	
t_{PHZ}	OEAB or $\overline{\text{OEBA}}$	B or A	1.5	4.5	5.7	1.5	6.9	1.5	6.5	ns
t_{PLZ}			1.4	3.4	4.7	1.4	5.8	1.4	5.4	

PRODUCT PREVIEW information concerns products in the formative or design phase of development. Characteristic data and other specifications are design goals. Texas Instruments reserves the right to change or discontinue these products without notice.



POST OFFICE BOX 655303 • DALLAS, TEXAS 75265

SN54ABT16500B, SN74ABT16500B
18-BIT UNIVERSAL BUS TRANSCEIVERS
WITH 3-STATE OUTPUTS

SCBS057G – DECEMBER 1990 – REVISED MAY 1997

PARAMETER MEASUREMENT INFORMATION

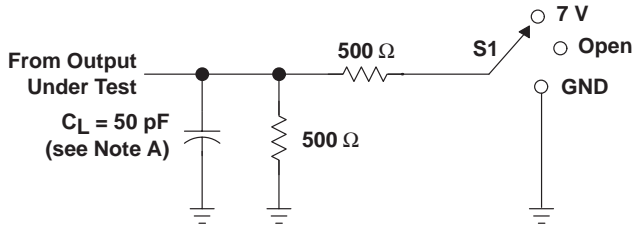

LOAD CIRCUIT

TEST	S1
t_{PLH}/t_{PHL}	Open
t_{PLZ}/t_{PZL}	7 V
t_{PHZ}/t_{PZH}	Open

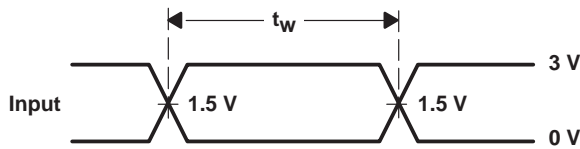

VOLTAGE WAVEFORMS
PULSE DURATION

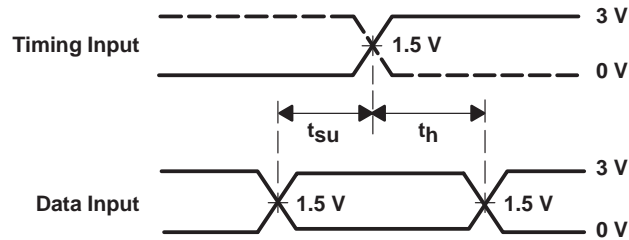

VOLTAGE WAVEFORMS
SETUP AND HOLD TIMES

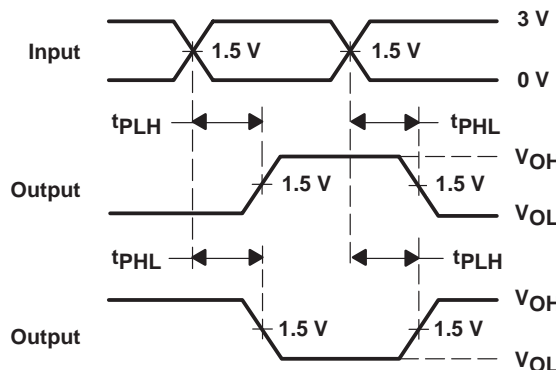

VOLTAGE WAVEFORMS
PROPAGATION DELAY TIMES
INVERTING AND NONINVERTING OUTPUTS

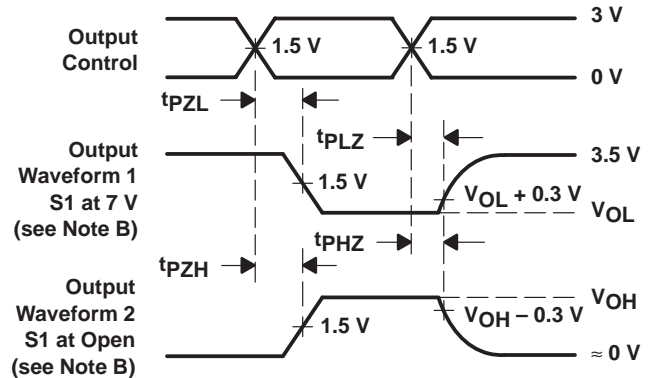

VOLTAGE WAVEFORMS
ENABLE AND DISABLE TIMES
LOW- AND HIGH-LEVEL ENABLING

- NOTES: A. C_L includes probe and jig capacitance.
 B. Waveform 1 is for an output with internal conditions such that the output is low except when disabled by the output control. Waveform 2 is for an output with internal conditions such that the output is high except when disabled by the output control.
 C. All input pulses are supplied by generators having the following characteristics: $PRR \leq 10 \text{ MHz}$, $Z_O = 50 \Omega$, $t_r \leq 2.5 \text{ ns}$, $t_f \leq 2.5 \text{ ns}$.
 D. The outputs are measured one at a time with one transition per measurement.

Figure 1. Load Circuit and Voltage Waveforms

TAPE AND REEL INFORMATION



QUADRANT ASSIGNMENTS FOR PIN 1 ORIENTATION IN TAPE



*All dimensions are nominal

Device	Package Type	Package Drawing	Pins	SPQ	Reel Diameter (mm)	Reel Width W1 (mm)	A0 (mm)	B0 (mm)	K0 (mm)	P1 (mm)	W (mm)	Pin1 Quadrant
SN74ABT16500BDGGR	TSSOP	DGG	56	2000	330.0	24.4	8.6	15.6	1.8	12.0	24.0	Q1
SN74ABT16500BDLR	SSOP	DL	56	1000	330.0	32.4	11.35	18.67	3.1	16.0	32.0	Q1

TAPE AND REEL BOX DIMENSIONS



*All dimensions are nominal

Device	Package Type	Package Drawing	Pins	SPQ	Length (mm)	Width (mm)	Height (mm)
SN74ABT16500BDGGR	TSSOP	DGG	56	2000	346.0	346.0	41.0
SN74ABT16500BDLR	SSOP	DL	56	1000	346.0	346.0	49.0

IMPORTANT NOTICE

Texas Instruments Incorporated and its subsidiaries (TI) reserve the right to make corrections, modifications, enhancements, improvements, and other changes to its products and services at any time and to discontinue any product or service without notice. Customers should obtain the latest relevant information before placing orders and should verify that such information is current and complete. All products are sold subject to TI's terms and conditions of sale supplied at the time of order acknowledgment.

TI warrants performance of its hardware products to the specifications applicable at the time of sale in accordance with TI's standard warranty. Testing and other quality control techniques are used to the extent TI deems necessary to support this warranty. Except where mandated by government requirements, testing of all parameters of each product is not necessarily performed.

TI assumes no liability for applications assistance or customer product design. Customers are responsible for their products and applications using TI components. To minimize the risks associated with customer products and applications, customers should provide adequate design and operating safeguards.

TI does not warrant or represent that any license, either express or implied, is granted under any TI patent right, copyright, mask work right, or other TI intellectual property right relating to any combination, machine, or process in which TI products or services are used. Information published by TI regarding third-party products or services does not constitute a license from TI to use such products or services or a warranty or endorsement thereof. Use of such information may require a license from a third party under the patents or other intellectual property of the third party, or a license from TI under the patents or other intellectual property of TI.

Reproduction of TI information in TI data books or data sheets is permissible only if reproduction is without alteration and is accompanied by all associated warranties, conditions, limitations, and notices. Reproduction of this information with alteration is an unfair and deceptive business practice. TI is not responsible or liable for such altered documentation. Information of third parties may be subject to additional restrictions.

Resale of TI products or services with statements different from or beyond the parameters stated by TI for that product or service voids all express and any implied warranties for the associated TI product or service and is an unfair and deceptive business practice. TI is not responsible or liable for any such statements.

TI products are not authorized for use in safety-critical applications (such as life support) where a failure of the TI product would reasonably be expected to cause severe personal injury or death, unless officers of the parties have executed an agreement specifically governing such use. Buyers represent that they have all necessary expertise in the safety and regulatory ramifications of their applications, and acknowledge and agree that they are solely responsible for all legal, regulatory and safety-related requirements concerning their products and any use of TI products in such safety-critical applications, notwithstanding any applications-related information or support that may be provided by TI. Further, Buyers must fully indemnify TI and its representatives against any damages arising out of the use of TI products in such safety-critical applications.

TI products are neither designed nor intended for use in military/aerospace applications or environments unless the TI products are specifically designated by TI as military-grade or "enhanced plastic." Only products designated by TI as military-grade meet military specifications. Buyers acknowledge and agree that any such use of TI products which TI has not designated as military-grade is solely at the Buyer's risk, and that they are solely responsible for compliance with all legal and regulatory requirements in connection with such use.

TI products are neither designed nor intended for use in automotive applications or environments unless the specific TI products are designated by TI as compliant with ISO/TS 16949 requirements. Buyers acknowledge and agree that, if they use any non-designated products in automotive applications, TI will not be responsible for any failure to meet such requirements.

Following are URLs where you can obtain information on other Texas Instruments products and application solutions:

Products

Amplifiers	amplifier.ti.com
Data Converters	dataconverter.ti.com
DSP	dsp.ti.com
Clocks and Timers	www.ti.com/clocks
Interface	interface.ti.com
Logic	logic.ti.com
Power Mgmt	power.ti.com
Microcontrollers	microcontroller.ti.com
RFID	www.ti-rfid.com
RF/IF and ZigBee® Solutions	www.ti.com/lprf

Applications

Audio	www.ti.com/audio
Automotive	www.ti.com/automotive
Broadband	www.ti.com/broadband
Digital Control	www.ti.com/digitalcontrol
Medical	www.ti.com/medical
Military	www.ti.com/military
Optical Networking	www.ti.com/opticalnetwork
Security	www.ti.com/security
Telephony	www.ti.com/telephony
Video & Imaging	www.ti.com/video
Wireless	www.ti.com/wireless

Mailing Address: Texas Instruments, Post Office Box 655303, Dallas, Texas 75265
Copyright © 2008, Texas Instruments Incorporated