

## FEATURES

- Members of the Texas Instruments Widebus™ Family
- State-of-the-Art EPIC-IIB™ BiCMOS Design Significantly Reduces Power Dissipation
- Latch-Up Performance Exceeds 500 mA Per JESD 70
- Typical  $V_{OLP}$  (Output Ground Bounce)  $<1$  V at  $V_{CC} = 5$  V,  $T_A = 25^\circ\text{C}$
- Distributed  $V_{CC}$  and GND Pin Configuration Minimizes High-Speed Switching Noise
- Flow-Through Architecture Optimizes PCB Layout
- High-Drive Outputs ( $-32\text{-mA } I_{OH}$ ,  $64\text{-mA } I_{OL}$ )
- Package Options Include Plastic 300-mil Shrink Small-Outline (DL), Thin Shrink Small-Outline (DGG), and Thin Very Small-Outline (DGV) Packages and 380-mil Fine-Pitch Ceramic Flat (WD) Package Using 25-mil Center-to-Center Spacings

## DESCRIPTION

The SN54ABT16244 and SN74ABT16244A are 16-bit buffers and line drivers designed specifically to improve both the performance and density of 3-state memory address drivers, clock drivers, and bus-oriented receivers and transmitters. These devices can be used as four 4-bit buffers, two 8-bit buffers, or one 16-bit buffer. These devices provide true outputs and symmetrical  $\overline{OE}$  (active-low output-enable) inputs.

To ensure the high-impedance state during power up or power down,  $\overline{OE}$  should be tied to  $V_{CC}$  through a pullup resistor; the minimum value of the resistor is determined by the current-sinking capability of the driver.

The SN54ABT16244 is characterized for operation over the full military temperature range of  $-55^\circ\text{C}$  to  $125^\circ\text{C}$ . The SN74ABT16244A is characterized for operation from  $-40^\circ\text{C}$  to  $85^\circ\text{C}$ .

SN54ABT16244... WD PACKAGE  
SN74ABT16244A... DGG, DGV, OR DL PACKAGE  
(TOP VIEW)

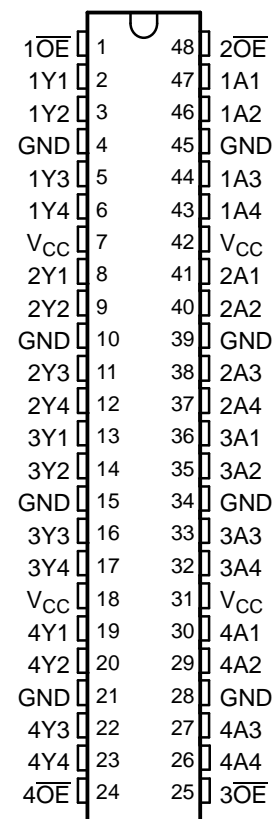

FUNCTION TABLE  
(EACH BUFFER)

INPUTS		OUTPUT
$\overline{OE}$	A	Y
L	H	H
L	L	L
H	X	Z



Please be aware that an important notice concerning availability, standard warranty, and use in critical applications of Texas Instruments semiconductor products and disclaimers thereto appears at the end of this data sheet.

Widebus, EPIC-IIB are trademarks of Texas Instruments.

**SN54ABT16244, SN74ABT16244A**  
**16-BIT BUFFERS/DRIVERS**  
**WITH 3-STATE OUTPUTS**

SCBS073H—SEPTEMBER 1991—REVISED AUGUST 2005

**LOGIC SYMBOL<sup>(1)</sup>**

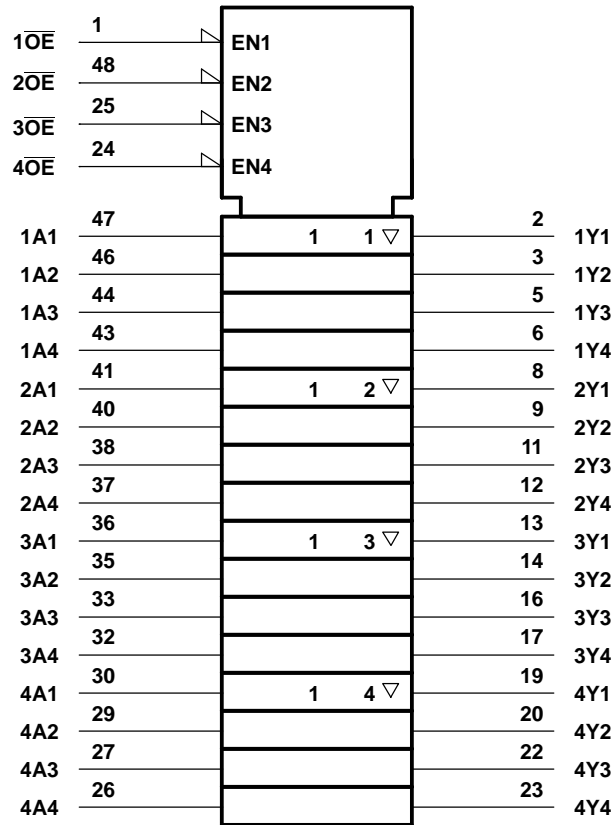

(1) This symbol is in accordance with ANSI/IEEE Std 91-1984 and IEC Publication 617-12.

**LOGIC DIAGRAM (POSITIVE LOGIC)**

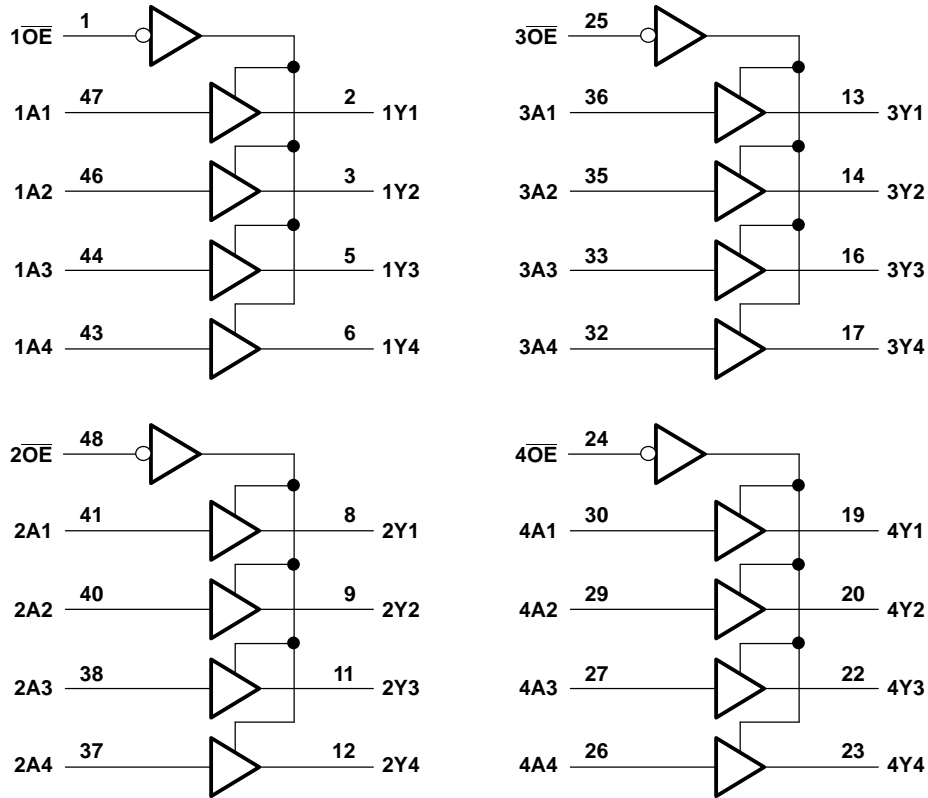

**Absolute Maximum Ratings<sup>(1)</sup>**

over operating free-air temperature range (unless otherwise noted)

		MIN	MAX	UNIT
$V_{CC}$	Supply voltage range	-0.5	7	V
$V_I$	Input voltage range <sup>(2)</sup>	-0.5	7	V
$V_O$	Voltage range applied to any output in the high or power-off state	-0.5	5.5	V
$I_O$	Current into any output in the low state	SN54ABT16244	96	mA
		SN74ABT16244A	128	
$I_{IK}$	Input clamp current	$V_I < 0$	-18	mA
$I_{OK}$	Output clamp current	$V_O < 0$	-50	mA
$\theta_{JA}$	Package thermal impedance <sup>(3)</sup>	DGG package	89	°C/W
		DGV package	93	
		DL package	94	
$T_{stg}$	Storage temperature range	-65	150	°C

- (1) Stresses beyond those listed under "absolute maximum ratings" may cause permanent damage to the device. These are stress ratings only, and functional operation of the device at these or any other conditions beyond those indicated under "recommended operating conditions" is not implied. Exposure to absolute-maximum-rated conditions for extended periods may affect device reliability
- (2) The input and output negative-voltage ratings may be exceeded if the input and output clamp-current ratings are observed.
- (3) The package thermal impedance is calculated in accordance with EIA/JEDEC Std JESD 51.

# SN54ABT16244, SN74ABT16244A

## 16-BIT BUFFERS/DRIVERS

### WITH 3-STATE OUTPUTS

SCBS073H—SEPTEMBER 1991—REVISED AUGUST 2005

### Recommended Operating Conditions<sup>(1)</sup>

		SN54ABT16244		SN74ABT16244A		UNIT
		MIN	MAX	MIN	MAX	
V <sub>CC</sub>	Supply voltage	4.5	5.5	4.5	5.5	V
V <sub>IH</sub>	High-level input voltage	2		2		V
V <sub>IL</sub>	Low-level input voltage		0.8		0.8	V
V <sub>I</sub>	Input voltage	0	V <sub>CC</sub>	0	V <sub>CC</sub>	V
I <sub>OH</sub>	High-level output current		-24		-32	mA
I <sub>OL</sub>	Low-level output current		48		64	mA
Δt/Δv	Input transition rise or fall rate	Outputs enabled		10	10	ns/V
T <sub>A</sub>	Operating free-air temperature	-55	125	-40	85	°C

(1) All unused inputs of the device must be held at V<sub>CC</sub> or GND to ensure proper device operation. Refer to the TI application report, *Implications of Slow or Floating CMOS Inputs*, literature number SCBA004.

### Electrical Characteristics

over recommended operating free-air temperature range (unless otherwise noted)

PARAMETER	TEST CONDITIONS	T <sub>A</sub> = 25°C <sup>(1)</sup>			SN54ABT16244		SN74ABT16244A		UNIT
		MIN	TYP <sup>(2)</sup>	MAX	MIN	MAX	MIN	MAX	
V <sub>IK</sub>	V <sub>CC</sub> = 4.5 V, I <sub>I</sub> = -18 mA			-1.2		-1.2		-1.2	V
V <sub>OH</sub>	V <sub>CC</sub> = 4.5 V, I <sub>OH</sub> = -3 mA	2.5			2.5		2.5		V
	V <sub>CC</sub> = 5 V, I <sub>OH</sub> = -3 mA	3			3		3		
	V <sub>CC</sub> = 4.5 V				2		2		
V <sub>OL</sub>	V <sub>CC</sub> = 4.5 V	I <sub>OL</sub> = 48 mA		0.55		0.55			V
		I <sub>OL</sub> = 64 mA		0.55 <sup>(3)</sup>			0.55		
V <sub>hys</sub>			100						mV
I <sub>I</sub>	V <sub>CC</sub> = 5.5 V, V <sub>I</sub> = V <sub>CC</sub> or GND			±1		±1		±1	μA
I <sub>OZH</sub>	V <sub>CC</sub> = 5.5 V, V <sub>O</sub> = 2.7 V			10 <sup>(4)</sup>		10		10 <sup>(4)</sup>	μA
I <sub>OZL</sub>	V <sub>CC</sub> = 5.5 V, V <sub>O</sub> = 0.5 V			-10 <sup>(4)</sup>		-10		-10 <sup>(4)</sup>	μA
I <sub>off</sub>	V <sub>CC</sub> = 0, V <sub>I</sub> or V <sub>O</sub> ≤ 5.5 V			±100				±100	μA
I <sub>CEX</sub>	V <sub>CC</sub> = 5.5 V, V <sub>O</sub> = 5.5 V	Outputs high		50		50		50	μA
I <sub>O</sub> <sup>(5)</sup>	V <sub>CC</sub> = 5.5 V, V <sub>O</sub> = 2.5 V	-50	-100	-180	-50	-180	-50	-180	mA
I <sub>CC</sub>	V <sub>CC</sub> = 5.5 V, I <sub>O</sub> = 0, V <sub>I</sub> = V <sub>CC</sub> or GND	Outputs high		3		2		3	mA
		Outputs low		32		32		32	
		Outputs disabled		3		2		3	
ΔI <sub>CC</sub> <sup>(6)</sup>	Data inputs V <sub>CC</sub> = 5.5 V, One input at 3.4 V, Other inputs at V <sub>CC</sub> or GND	Outputs enabled		0.05		1.5		0.05	mA
		Outputs disabled		0.05		1		0.05	
	Control inputs V <sub>CC</sub> = 5.5 V, One input at 3.4 V, Other inputs at V <sub>CC</sub> or GND			0.05		1.5		0.05	
C <sub>i</sub>	V <sub>I</sub> = 2.5 V or 0.5 V			3					pF
C <sub>o</sub>	V <sub>O</sub> = 2.5 V or 0.5 V			6					pF

(1) Characteristics for T<sub>A</sub> = 25°C apply to the SN74ABT16244A only.

(2) All typical values are at V<sub>CC</sub> = 5 V.

(3) On products compliant to MIL-PRF-38535, this parameter does not apply.

(4) This data-sheet limit may vary among suppliers.

(5) Not more than one output should be tested at a time, and the duration of the test should not exceed one second.

(6) This is the increase in supply current for each input that is at the specified TTL voltage level rather than V<sub>CC</sub> or GND.

### Switching Characteristics

over recommended ranges of supply voltage and operating free-air temperature,  $C_L = 50$  pF  
(unless otherwise noted) (see [Figure 1](#) )

PARAMETER	FROM (INPUT)	TO (OUTPUT)	SN54ABT16244					UNIT
			$V_{CC} = 5$ V, $T_A = 25^\circ\text{C}$			MIN	MAX	
			MIN	TYP	MAX			
$t_{PLH}$	A	Y	0.7	2.3	3.2	0.7	3.6	ns
$t_{PHL}$			0.5	2.6	3.7	0.5	4.2	
$t_{PZH}$	$\overline{OE}$	Y	0.7	3	4	0.7	4.9	ns
$t_{PZL}$			0.9	3.2	5.5	0.9	6.5	
$t_{PHZ}$	$\overline{OE}$	Y	1.7	3.6	5	1.7	6	ns
$t_{PLZ}$			1.5	2.9	4.7	1.5	5.7	

### Switching Characteristics

over recommended ranges of supply voltage and operating free-air temperature,  $C_L = 50$  pF  
(unless otherwise noted) (see [Figure 1](#) )

PARAMETER	FROM (INPUT)	TO (OUTPUT)	SN74ABT16244A					UNIT
			$V_{CC} = 5$ V, $T_A = 25^\circ\text{C}$			MIN	MAX	
			MIN	TYP	MAX			
$t_{PLH}$	A or B	Y	1	2.3	3.2	1	3.5	ns
$t_{PHL}$			1	2.6	3.7	1	4.1	
$t_{PZH}$	$\overline{OE}$	Y	1	3	3.8	1	4.8	ns
$t_{PZL}$			1	3.2	4	1	4.8	
$t_{PHZ}$	$\overline{OE}$	Y	1	3.6	4.4	1	4.8	ns
$t_{PLZ}$			1	2.9	3.7	1	4.1	

PARAMETER MEASUREMENT INFORMATION

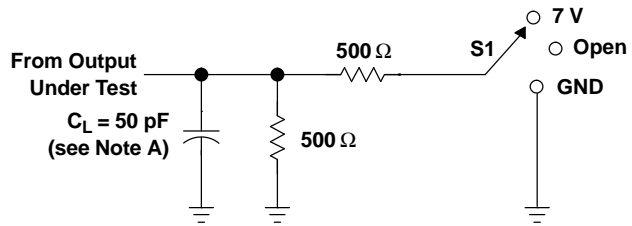

LOAD CIRCUIT

TEST	S1
$t_{PLH}/t_{PHL}$	Open
$t_{PLZ}/t_{PZL}$	7 V
$t_{PHZ}/t_{PZH}$	Open

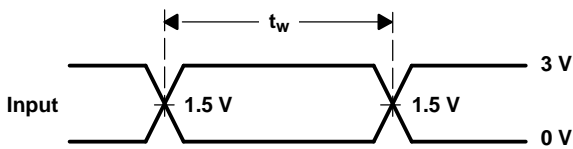

VOLTAGE WAVEFORMS  
 PULSE DURATION

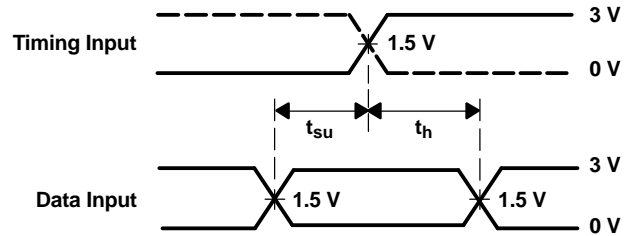

VOLTAGE WAVEFORMS  
 SETUP AND HOLD TIMES

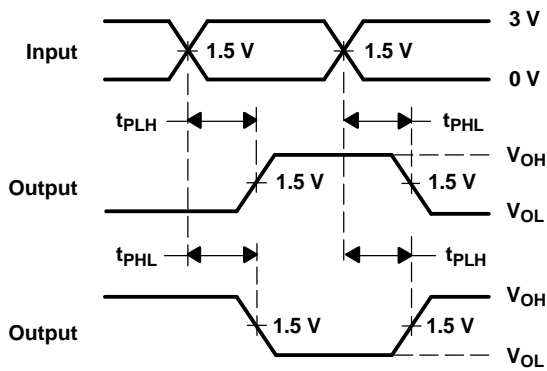

VOLTAGE WAVEFORMS  
 PROPAGATION DELAY TIMES  
 INVERTING AND NONINVERTING OUTPUTS

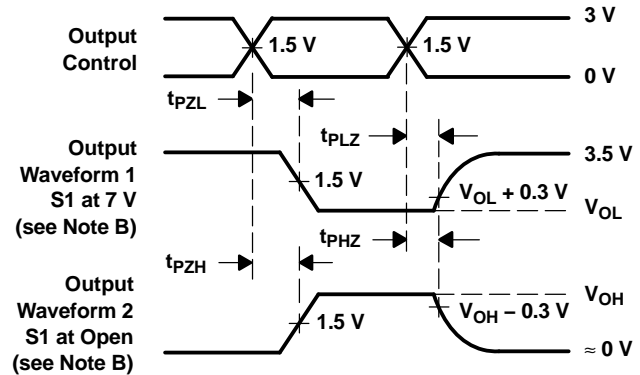

VOLTAGE WAVEFORMS  
 ENABLE AND DISABLE TIMES  
 LOW- AND HIGH-LEVEL ENABLING

- NOTES: A.  $C_L$  includes probe and jig capacitance.  
 B. Waveform 1 is for an output with internal conditions such that the output is low, except when disabled by the output control. Waveform 2 is for an output with internal conditions such that the output is high, except when disabled by the output control.  
 C. All input pulses are supplied by generators having the following characteristics:  $PRR \leq 10 \text{ MHz}$ ,  $Z_O = 50 \Omega$ ,  $t_r \leq 2.5 \text{ ns}$ ,  $t_f \leq 2.5 \text{ ns}$ .  
 D. The outputs are measured one at a time, with one transition per measurement.

Figure 1. Load Circuit and Voltage Waveforms

**PACKAGING INFORMATION**

Orderable Device	Status <sup>(1)</sup>	Package Type	Package Drawing	Pins	Package Qty	Eco Plan <sup>(2)</sup>	Lead/Ball Finish	MSL Peak Temp <sup>(3)</sup>
5962-9317401MXA	ACTIVE	CFP	WD	48	1	TBD	A42 SNPB	N / A for Pkg Type
74ABT16244ADGGRG4	ACTIVE	TSSOP	DGG	48	2000	Green (RoHS & no Sb/Br)	CU NIPDAU	Level-1-260C-UNLIM
74ABT16244ADGVRE4	ACTIVE	TVSOP	DGV	48	2000	Green (RoHS & no Sb/Br)	CU NIPDAU	Level-1-260C-UNLIM
SN74ABT16244ADGGR	ACTIVE	TSSOP	DGG	48	2000	Green (RoHS & no Sb/Br)	CU NIPDAU	Level-1-260C-UNLIM
SN74ABT16244ADGVR	ACTIVE	TVSOP	DGV	48	2000	Green (RoHS & no Sb/Br)	CU NIPDAU	Level-1-260C-UNLIM
SN74ABT16244ADL	ACTIVE	SSOP	DL	48	25	Green (RoHS & no Sb/Br)	CU NIPDAU	Level-1-260C-UNLIM
SN74ABT16244ADLG4	ACTIVE	SSOP	DL	48	25	Green (RoHS & no Sb/Br)	CU NIPDAU	Level-1-260C-UNLIM
SN74ABT16244ADLR	ACTIVE	SSOP	DL	48	1000	Green (RoHS & no Sb/Br)	CU NIPDAU	Level-1-260C-UNLIM
SN74ABT16244ADLRG4	ACTIVE	SSOP	DL	48	1000	Green (RoHS & no Sb/Br)	CU NIPDAU	Level-1-260C-UNLIM
SNJ54ABT16244WD	ACTIVE	CFP	WD	48	1	TBD	A42 SNPB	N / A for Pkg Type

<sup>(1)</sup> The marketing status values are defined as follows:

**ACTIVE:** Product device recommended for new designs.

**LIFEBUY:** TI has announced that the device will be discontinued, and a lifetime-buy period is in effect.

**NRND:** Not recommended for new designs. Device is in production to support existing customers, but TI does not recommend using this part in a new design.

**PREVIEW:** Device has been announced but is not in production. Samples may or may not be available.

**OBSELETE:** TI has discontinued the production of the device.

<sup>(2)</sup> Eco Plan - The planned eco-friendly classification: Pb-Free (RoHS), Pb-Free (RoHS Exempt), or Green (RoHS & no Sb/Br) - please check <http://www.ti.com/productcontent> for the latest availability information and additional product content details.

**TBD:** The Pb-Free/Green conversion plan has not been defined.

**Pb-Free (RoHS):** TI's terms "Lead-Free" or "Pb-Free" mean semiconductor products that are compatible with the current RoHS requirements for all 6 substances, including the requirement that lead not exceed 0.1% by weight in homogeneous materials. Where designed to be soldered at high temperatures, TI Pb-Free products are suitable for use in specified lead-free processes.

**Pb-Free (RoHS Exempt):** This component has a RoHS exemption for either 1) lead-based flip-chip solder bumps used between the die and package, or 2) lead-based die adhesive used between the die and leadframe. The component is otherwise considered Pb-Free (RoHS compatible) as defined above.

**Green (RoHS & no Sb/Br):** TI defines "Green" to mean Pb-Free (RoHS compatible), and free of Bromine (Br) and Antimony (Sb) based flame retardants (Br or Sb do not exceed 0.1% by weight in homogeneous material)

<sup>(3)</sup> MSL, Peak Temp. -- The Moisture Sensitivity Level rating according to the JEDEC industry standard classifications, and peak solder temperature.

**Important Information and Disclaimer:**The information provided on this page represents TI's knowledge and belief as of the date that it is provided. TI bases its knowledge and belief on information provided by third parties, and makes no representation or warranty as to the accuracy of such information. Efforts are underway to better integrate information from third parties. TI has taken and continues to take reasonable steps to provide representative and accurate information but may not have conducted destructive testing or chemical analysis on incoming materials and chemicals. TI and TI suppliers consider certain information to be proprietary, and thus CAS numbers and other limited information may not be available for release.

In no event shall TI's liability arising out of such information exceed the total purchase price of the TI part(s) at issue in this document sold by TI to Customer on an annual basis.

WD (R-GDFP-F\*\*)

CERAMIC DUAL FLATPACK

48 LEADS SHOWN

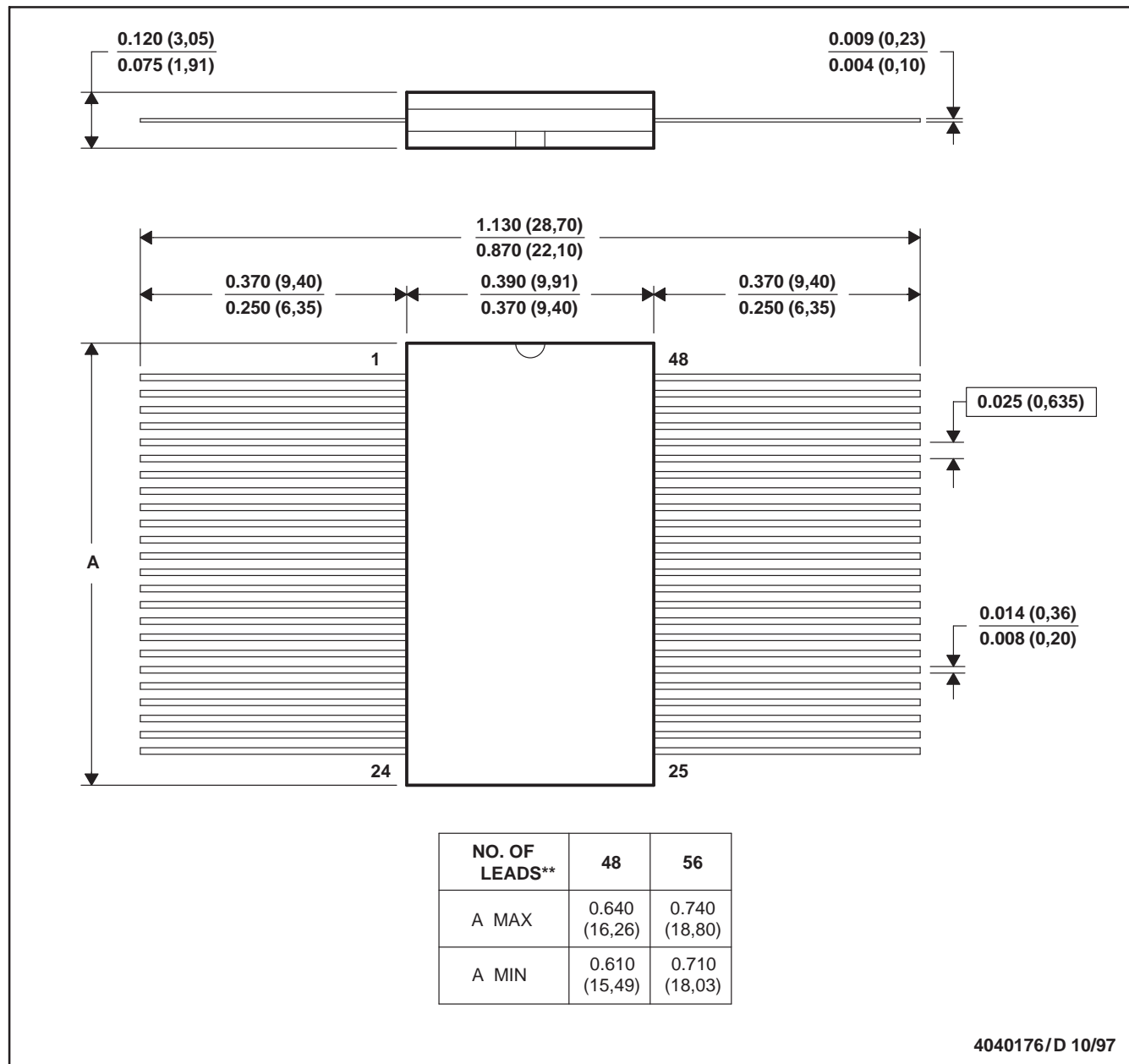

- NOTES: A. All linear dimensions are in inches (millimeters).  
 B. This drawing is subject to change without notice.  
 C. This package can be hermetically sealed with a ceramic lid using glass frit.  
 D. Index point is provided on cap for terminal identification only  
 E. Falls within MIL STD 1835: GDFP1-F48 and JEDEC MO-146AA  
 GDFP1-F56 and JEDEC MO-146AB

DGV (R-PDSO-G\*\*)

PLASTIC SMALL-OUTLINE

24 PINS SHOWN



- NOTES: A. All linear dimensions are in millimeters.  
 B. This drawing is subject to change without notice.  
 C. Body dimensions do not include mold flash or protrusion, not to exceed 0,15 per side.  
 D. Falls within JEDEC: 24/48 Pins – MO-153  
 14/16/20/56 Pins – MO-194

DL (R-PDSO-G\*\*)

PLASTIC SMALL-OUTLINE PACKAGE

48 PINS SHOWN



- NOTES: A. All linear dimensions are in inches (millimeters).  
 B. This drawing is subject to change without notice.  
 C. Body dimensions do not include mold flash or protrusion not to exceed 0.006 (0,15).  
 D. Falls within JEDEC MO-118

DGG (R-PDSO-G\*\*)

PLASTIC SMALL-OUTLINE PACKAGE

48 PINS SHOWN



- NOTES: A. All linear dimensions are in millimeters.  
 B. This drawing is subject to change without notice.  
 C. Body dimensions do not include mold protrusion not to exceed 0,15.  
 D. Falls within JEDEC MO-153

## IMPORTANT NOTICE

Texas Instruments Incorporated and its subsidiaries (TI) reserve the right to make corrections, modifications, enhancements, improvements, and other changes to its products and services at any time and to discontinue any product or service without notice. Customers should obtain the latest relevant information before placing orders and should verify that such information is current and complete. All products are sold subject to TI's terms and conditions of sale supplied at the time of order acknowledgment.

TI warrants performance of its hardware products to the specifications applicable at the time of sale in accordance with TI's standard warranty. Testing and other quality control techniques are used to the extent TI deems necessary to support this warranty. Except where mandated by government requirements, testing of all parameters of each product is not necessarily performed.

TI assumes no liability for applications assistance or customer product design. Customers are responsible for their products and applications using TI components. To minimize the risks associated with customer products and applications, customers should provide adequate design and operating safeguards.

TI does not warrant or represent that any license, either express or implied, is granted under any TI patent right, copyright, mask work right, or other TI intellectual property right relating to any combination, machine, or process in which TI products or services are used. Information published by TI regarding third-party products or services does not constitute a license from TI to use such products or services or a warranty or endorsement thereof. Use of such information may require a license from a third party under the patents or other intellectual property of the third party, or a license from TI under the patents or other intellectual property of TI.

Reproduction of information in TI data books or data sheets is permissible only if reproduction is without alteration and is accompanied by all associated warranties, conditions, limitations, and notices. Reproduction of this information with alteration is an unfair and deceptive business practice. TI is not responsible or liable for such altered documentation.

Resale of TI products or services with statements different from or beyond the parameters stated by TI for that product or service voids all express and any implied warranties for the associated TI product or service and is an unfair and deceptive business practice. TI is not responsible or liable for any such statements.

Following are URLs where you can obtain information on other Texas Instruments products and application solutions:

<b>Products</b>		<b>Applications</b>	
Amplifiers	<a href="http://amplifier.ti.com">amplifier.ti.com</a>	Audio	<a href="http://www.ti.com/audio">www.ti.com/audio</a>
Data Converters	<a href="http://dataconverter.ti.com">dataconverter.ti.com</a>	Automotive	<a href="http://www.ti.com/automotive">www.ti.com/automotive</a>
DSP	<a href="http://dsp.ti.com">dsp.ti.com</a>	Broadband	<a href="http://www.ti.com/broadband">www.ti.com/broadband</a>
Interface	<a href="http://interface.ti.com">interface.ti.com</a>	Digital Control	<a href="http://www.ti.com/digitalcontrol">www.ti.com/digitalcontrol</a>
Logic	<a href="http://logic.ti.com">logic.ti.com</a>	Military	<a href="http://www.ti.com/military">www.ti.com/military</a>
Power Mgmt	<a href="http://power.ti.com">power.ti.com</a>	Optical Networking	<a href="http://www.ti.com/opticalnetwork">www.ti.com/opticalnetwork</a>
Microcontrollers	<a href="http://microcontroller.ti.com">microcontroller.ti.com</a>	Security	<a href="http://www.ti.com/security">www.ti.com/security</a>
Low Power Wireless	<a href="http://www.ti.com/lpw">www.ti.com/lpw</a>	Telephony	<a href="http://www.ti.com/telephony">www.ti.com/telephony</a>
		Video & Imaging	<a href="http://www.ti.com/video">www.ti.com/video</a>
		Wireless	<a href="http://www.ti.com/wireless">www.ti.com/wireless</a>

Mailing Address: Texas Instruments  
Post Office Box 655303 Dallas, Texas 75265