

**SN5414, SN54LS14,  
SN7414, SN74LS14**  
**HEX SCHMITT-TRIGGER INVERTERS**  
SDLS049B – DECEMBER 1983 – REVISED FEBRUARY 2002

- Operation From Very Slow Edges
- Improved Line-Receiving Characteristics
- High Noise Immunity

**description**

Each circuit functions as an inverter, but because of the Schmitt action, it has different input threshold levels for positive-going ( $V_{T+}$ ) and negative-going ( $V_{T-}$ ) signals.

These circuits are temperature compensated and can be triggered from the slowest of input ramps and still give clean, jitter-free output signals.

**SN5414, SN54LS14 . . . J OR W PACKAGE**  
**SN7414 . . . D, N, OR NS PACKAGE**  
**SN74LS14 . . . D, DB, OR N PACKAGE**  
**(TOP VIEW)**

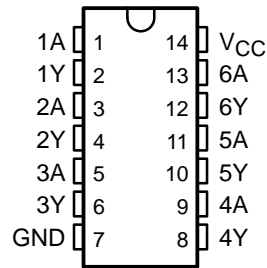

**SN54LS14 . . . FK PACKAGE**  
**(TOP VIEW)**

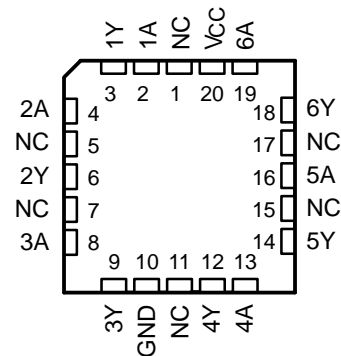

NC – No internal connection

**ORDERING INFORMATION**

$T_A$	PACKAGE†		ORDERABLE PART NUMBER	TOP-SIDE MARKING
0°C to 70°C	PDIP – N	Tube	SN7414N	SN7414N
		Tube	SN74LS14N	SN74LS14N
	SOIC – D	Tube	SN7414D	7414
		Tape and reel	SN7414DR	
		Tube	SN74LS14D	LS14
	Tape and reel	SN74LS14DR		
SOP – NS	Tape and reel	SN7414NSR	SN7414	
SSOP – DB	Tape and reel	SN74LS14DBR	LS14	
–55°C to 125°C	CDIP – J	Tube	SN5414J	SN5414J
		Tube	SNJ5414J	SNJ5414J
		Tube	SN54LS14J	SN54LS14J
		Tube	SNJ54LS14J	SNJ54LS14J
	CFP – W	Tube	SNJ5414W	SNJ5414W
		Tube	SNJ54LS14W	SNJ54LS14W
LCCC – FK	Tube	SNJ54LS14FK	SNJ54LS14FK	

† Package drawings, standard packing quantities, thermal data, symbolization, and PCB design guidelines are available at [www.ti.com/sc/package](http://www.ti.com/sc/package).



Please be aware that an important notice concerning availability, standard warranty, and use in critical applications of Texas Instruments semiconductor products and disclaimers thereto appears at the end of this data sheet.

PRODUCTION DATA information is current as of publication date. Products conform to specifications per the terms of Texas Instruments standard warranty. Production processing does not necessarily include testing of all parameters.



POST OFFICE BOX 655303 • DALLAS, TEXAS 75265

Copyright © 2002, Texas Instruments Incorporated  
On products compliant to MIL-PRF-38535, all parameters are tested unless otherwise noted. On all other products, production processing does not necessarily include testing of all parameters.

# SN5414, SN54LS14, SN7414, SN74LS14 HEX SCHMITT-TRIGGER INVERTERS

SDLS049B – DECEMBER 1983 – REVISED FEBRUARY 2002

---

## logic diagram (positive logic)

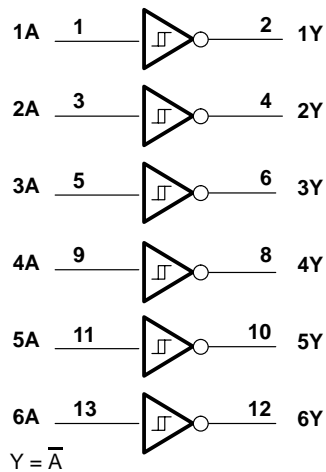

Pin numbers shown are for the D, DB, J, N, NS, and W packages.

schematic

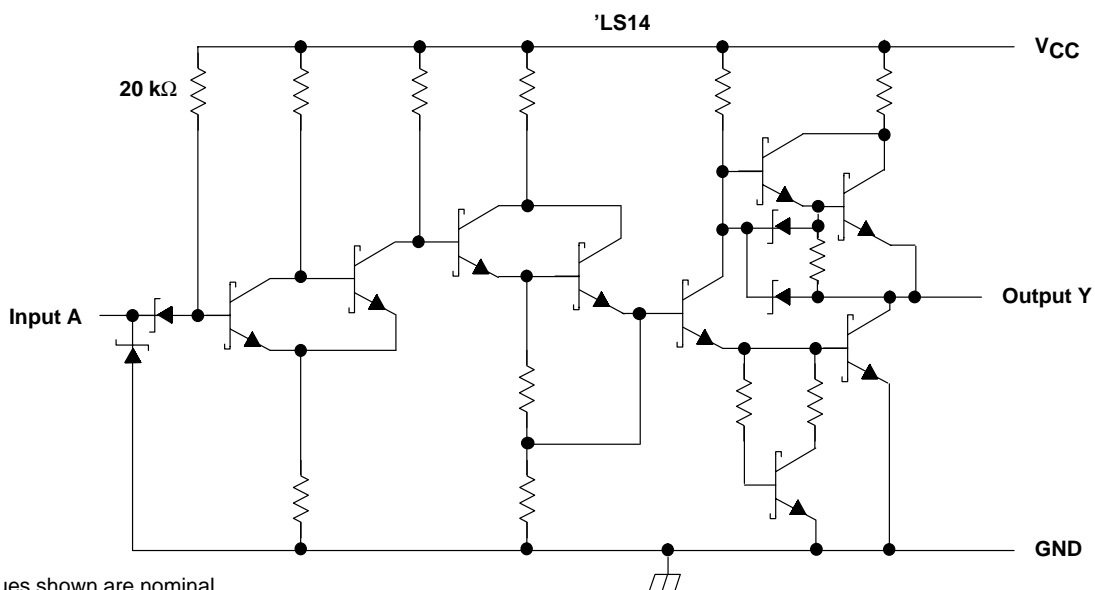
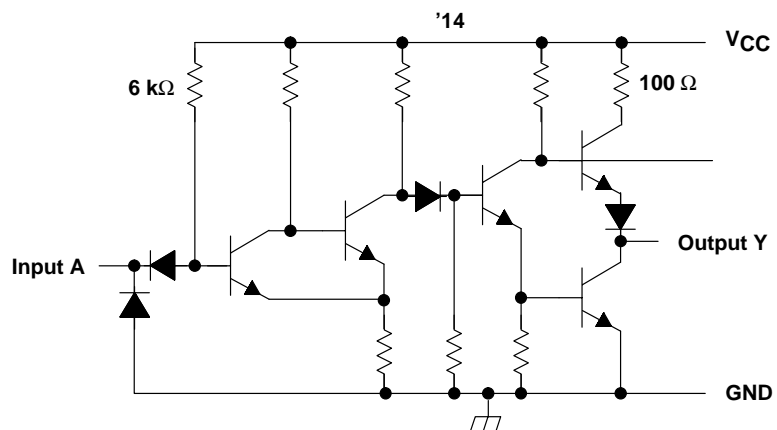

Resistor values shown are nominal.

**SN5414, SN54LS14,  
SN7414, SN74LS14  
HEX SCHMITT-TRIGGER INVERTERS**

SDLS049B – DECEMBER 1983 – REVISED FEBRUARY 2002

**absolute maximum ratings over operating free-air temperature (unless otherwise noted)†**

Supply voltage, $V_{CC}$ (see Note 1) .....	7 V
Input voltage: '14 .....	5.5 V
'LS14 .....	7 V
Package thermal impedance, $\theta_{JA}$ (see Note 2): D package .....	86°C/W
DB package .....	96°C/W
N package .....	80°C/W
NS package .....	76°C/W
Storage temperature range, $T_{stg}$ .....	-65°C to 150°C

† Stresses beyond those listed under “absolute maximum ratings” may cause permanent damage to the device. These are stress ratings only, and functional operation of the device at these or any other conditions beyond those indicated under “recommended operating conditions” is not implied. Exposure to absolute-maximum-rated conditions for extended periods may affect device reliability.

- NOTES: 1. Voltage values are with respect to network ground terminal.  
2. The package thermal impedance is calculated in accordance with JESD 51-7

**recommended operating conditions**

	SN5414			SN7414			UNIT
	MIN	NOM	MAX	MIN	NOM	MAX	
$V_{CC}$ Supply voltage	4.5	5	5.5	4.75	5	5.25	V
$I_{OH}$ High-level output current			-0.8			-0.8	mA
$I_{OL}$ Low-level output current			16			16	mA
$T_A$ Operating free-air temperature	-55		125	0		70	°C

**electrical characteristics over recommended operating free-air temperature range (unless otherwise noted)**

PARAMETER	TEST CONDITIONS‡	SN5414 SN7414			UNIT
		MIN	TYP§	MAX	
$V_{T+}$	$V_{CC} = 5 V$	1.5	1.7	2	V
$V_{T-}$	$V_{CC} = 5 V$	0.6	0.9	1.1	V
Hysteresis ( $V_{T+} - V_{T-}$ )	$V_{CC} = 5 V$	0.4	0.8		V
$V_{IK}$	$V_{CC} = \text{MIN}, I_I = -12 \text{ mA}$			-1.5	V
$V_{OH}$	$V_{CC} = \text{MIN}, V_I = 0.6 V, I_{OH} = -0.8 \text{ mA}$	2.4	3.4		V
$V_{OL}$	$V_{CC} = \text{MIN}, V_I = 2 V, I_{OL} = 16 \text{ mA}$		0.2	0.4	V
$I_{T+}$	$V_{CC} = 5 V, V_I = V_{T+}$		-0.43		mA
$I_{T-}$	$V_{CC} = 5 V, V_I = V_{T-}$		-0.56		mA
$I_I$	$V_{CC} = \text{MAX}, V_I = 5.5 V$			1	mA
$I_{IH}$	$V_{CC} = \text{MAX}, V_{IH} = 2.4 V$			40	µA
$I_{IL}$	$V_{CC} = \text{MAX}, V_{IL} = 0.4 V$		-0.8	-1.2	mA
$I_{OS}¶$	$V_{CC} = \text{MAX}$	-18		-55	mA
$I_{CCH}$	$V_{CC} = \text{MAX}$		22	36	mA
$I_{CCL}$	$V_{CC} = \text{MAX}$		39	60	mA

‡ For conditions shown as MIN or MAX, use the appropriate value specified under recommended operating conditions.

§ All typical values are at  $V_{CC} = 5 V, T_A = 25^\circ C$ .

¶ Not more than one output should be shorted at a time.



**switching characteristics,  $V_{CC} = 5\text{ V}$ ,  $T_A = 25^\circ\text{C}$  (see Figure 1)**

PARAMETER	FROM (INPUT)	TO (OUTPUT)	TEST CONDITIONS	SN5414 SN7414			UNIT
				MIN	TYP	MAX	
$t_{PLH}$	A	Y	$R_L = 400\ \Omega$ , $C_L = 15\ \text{pF}$		15	22	ns
$t_{PHL}$					15	22	

**recommended operating conditions**

	SN54LS14			SN74LS14			UNIT
	MIN	NOM	MAX	MIN	NOM	MAX	
$V_{CC}$ Supply voltage	4.5	5	5.5	4.75	5	5.25	V
$I_{OH}$ High-level output current			-0.4			-0.4	mA
$I_{OL}$ Low-level output current			4			8	mA
$T_A$ Operating free-air temperature	-55		125	0		70	$^\circ\text{C}$

**electrical characteristics over recommended operating free-air temperature range (unless otherwise noted)**

PARAMETER	TEST CONDITIONS†	SN54LS14			SN74LS14			UNIT
		MIN	TYP‡	MAX	MIN	TYP‡	MAX	
$V_{T+}$	$V_{CC} = 5\text{ V}$	1.4	1.6	1.9	1.4	1.6	1.9	V
$V_{T-}$	$V_{CC} = 5\text{ V}$	0.5	0.8	1	0.5	0.8	1	V
Hysteresis ( $V_{T+} - V_{T-}$ )	$V_{CC} = 5\text{ V}$	0.4	0.8		0.4	0.8		V
$V_{IK}$	$V_{CC} = \text{MIN}$ , $I_I = -18\text{ mA}$			-1.5			-1.5	V
$V_{OH}$	$V_{CC} = \text{MIN}$ , $V_I = 0.5\text{ V}$ , $I_{OH} = -0.4\text{ mA}$	2.5	3.4		2.7	3.4		V
$V_{OL}$	$V_{CC} = \text{MIN}$ , $V_I = -1.9\text{ V}$		0.25	0.4		0.25	0.4	V
						0.35	0.5	
$I_{T+}$	$V_{CC} = 5\text{ V}$ , $V_I = V_{T+}$		-0.14			-0.14		mA
$I_{T-}$	$V_{CC} = 5\text{ V}$ , $V_I = V_{T-}$		-0.18			-0.18		mA
$I_I$	$V_{CC} = \text{MAX}$ , $V_I = 7\text{ V}$			0.1			0.1	mA
$I_{IH}$	$V_{CC} = \text{MAX}$ , $V_{IH} = 2.7\text{ V}$			20			20	$\mu\text{A}$
$I_{IL}$	$V_{CC} = \text{MAX}$ , $V_{IL} = 0.4\text{ V}$			-0.4			-0.4	mA
$I_{OS}^{\S}$	$V_{CC} = \text{MAX}$	-20		-100	-20		-100	mA
$I_{CCH}$	$V_{CC} = \text{MAX}$		8.6	16		8.6	16	mA
$I_{CCL}$	$V_{CC} = \text{MAX}$		12	21		12	21	mA

† For conditions shown as MIN or MAX, use the appropriate value specified under recommended operating conditions.

‡ All typical values are at  $V_{CC} = 5\text{ V}$ ,  $T_A = 25^\circ\text{C}$ .

§ Not more than one output should be shorted at a time, and duration of the short-circuit should not exceed one second.

**switching characteristics,  $V_{CC} = 5\text{ V}$ ,  $T_A = 25^\circ\text{C}$  (see Figure 2)**

PARAMETER	FROM (INPUT)	TO (OUTPUT)	TEST CONDITIONS	MIN	TYP	MAX	UNIT
$t_{PLH}$	A	Y	$R_L = 2\ \text{k}\Omega$ , $C_L = 15\ \text{pF}$		15	22	ns
$t_{PHL}$					15	22	

**SN5414, SN54LS14,  
SN7414, SN74LS14  
HEX SCHMITT-TRIGGER INVERTERS**

SDLS049B – DECEMBER 1983 – REVISED FEBRUARY 2002

**PARAMETER MEASUREMENT INFORMATION  
SERIES 54/74 DEVICES**

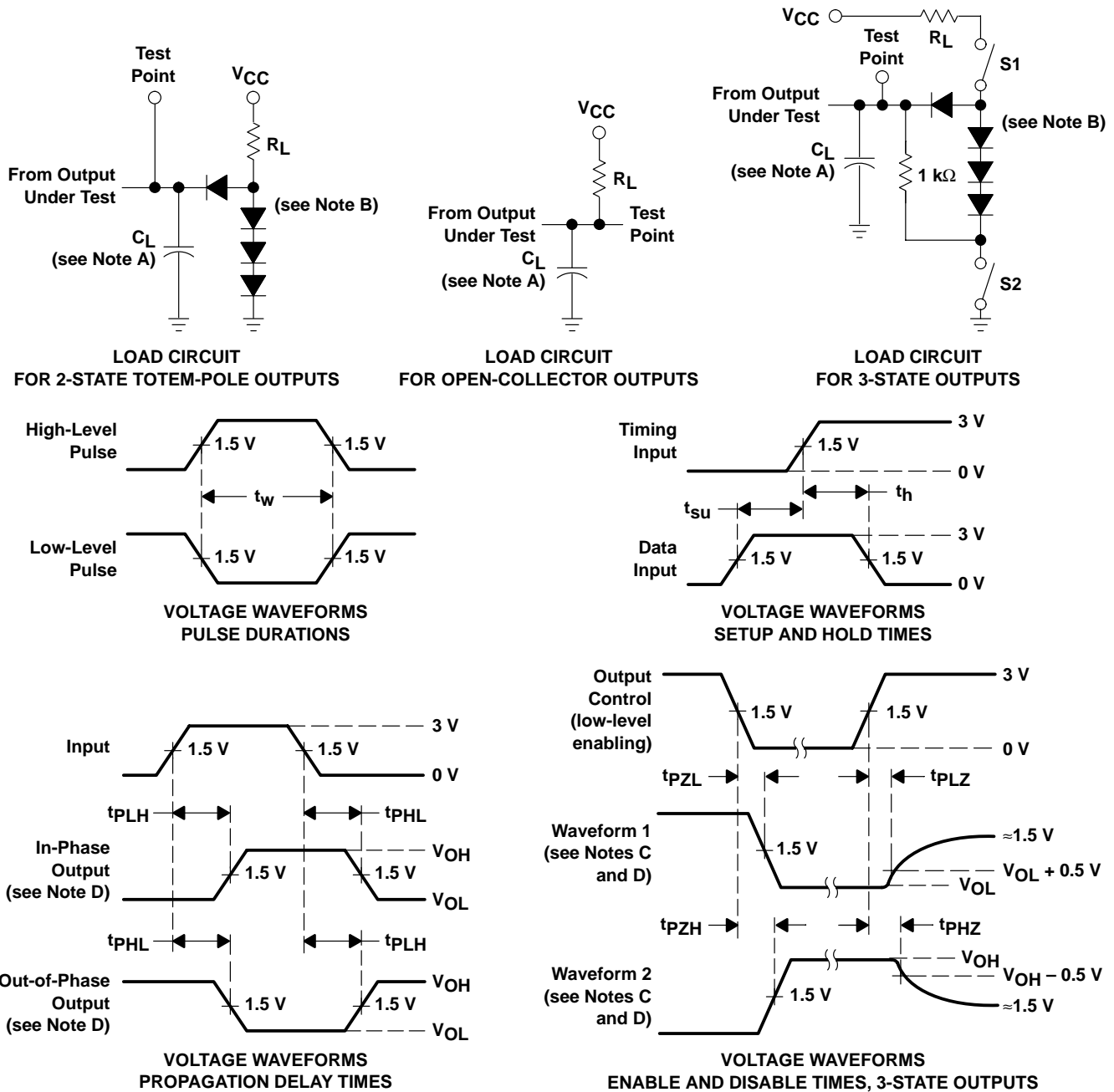

- NOTES: A.  $C_L$  includes probe and jig capacitance.  
 B. All diodes are 1N3064 or equivalent.  
 C. Waveform 1 is for an output with internal conditions such that the output is low except when disabled by the output control. Waveform 2 is for an output with internal conditions such that the output is high except when disabled by the output control.  
 D. S1 and S2 are closed for  $t_{PLH}$ ,  $t_{PHL}$ ,  $t_{PHZ}$ , and  $t_{PLZ}$ ; S1 is open and S2 is closed for  $t_{PZH}$ ; S1 is closed and S2 is open for  $t_{PZL}$ .  
 E. All input pulses are supplied by generators having the following characteristics:  $PRR \leq 1$  MHz,  $Z_O \approx 50 \Omega$ ;  $t_r$  and  $t_f \leq 7$  ns for Series 54/74 devices and  $t_r$  and  $t_f \leq 2.5$  ns for Series 54S/74S devices.  
 F. The outputs are measured one at a time with one input transition per measurement.

**Figure 1. Load Circuits and Voltage Waveforms**

**PARAMETER MEASUREMENT INFORMATION**  
**SERIES 54LS/74LS DEVICES**

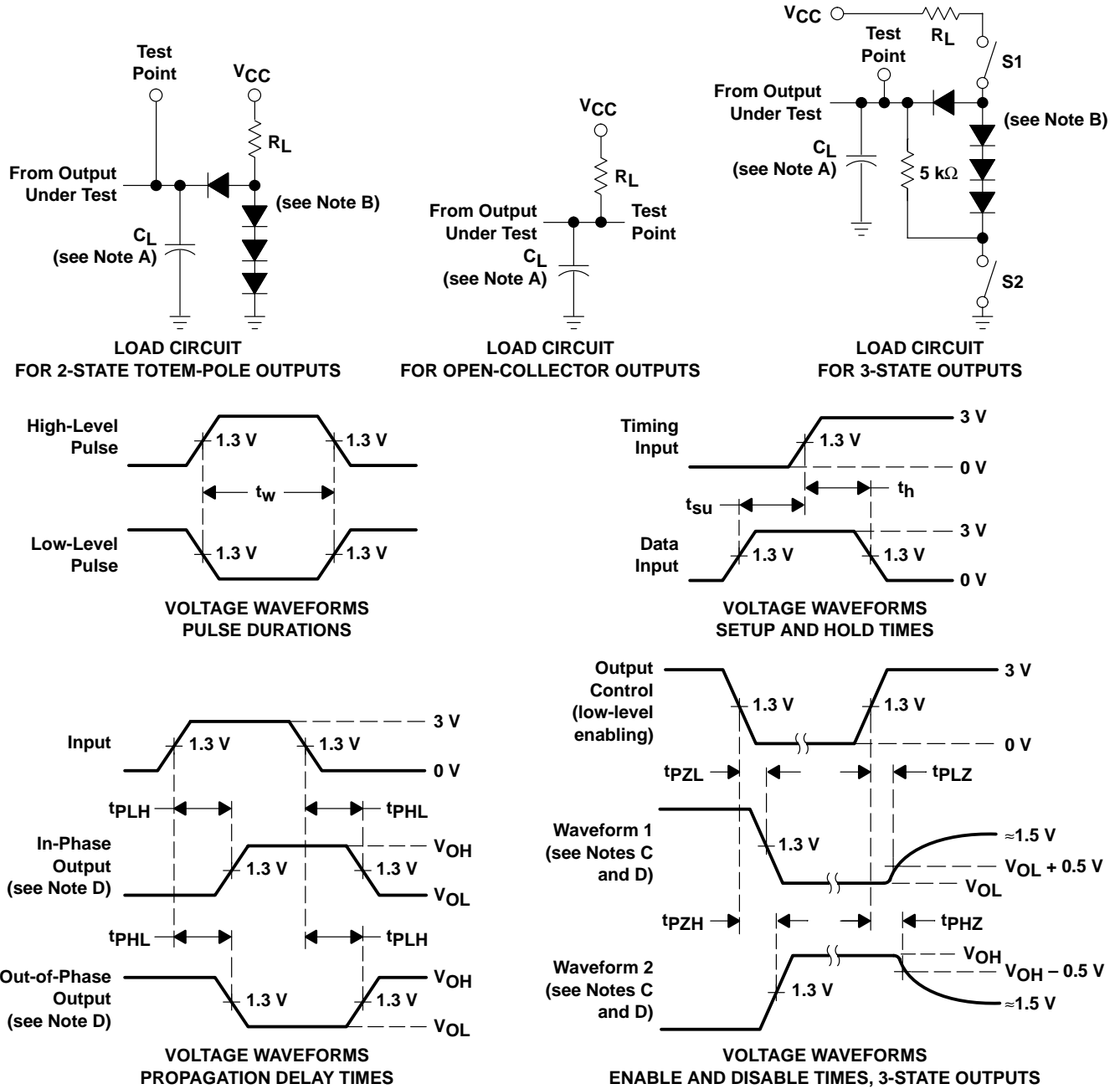

- NOTES: A.  $C_L$  includes probe and jig capacitance.  
 B. All diodes are 1N3064 or equivalent.  
 C. Waveform 1 is for an output with internal conditions such that the output is low except when disabled by the output control. Waveform 2 is for an output with internal conditions such that the output is high except when disabled by the output control.  
 D. S1 and S2 are closed for  $t_{PLH}$ ,  $t_{PHL}$ ,  $t_{PHZ}$ , and  $t_{PLZ}$ ; S1 is open and S2 is closed for  $t_{PZH}$ ; S1 is closed and S2 is open for  $t_{PZL}$ .  
 E. Phase relationships between inputs and outputs have been chosen arbitrarily for these examples.  
 F. All input pulses are supplied by generators having the following characteristics:  $PRR \leq 1$  MHz,  $Z_O \approx 50 \Omega$ ,  $t_r \leq 1.5$  ns,  $t_f \leq 2.6$  ns.  
 G. The outputs are measured one at a time with one input transition per measurement.

**Figure 2. Load Circuits and Voltage Waveforms**