

**SN5412, SN54LS12
SN7412, SN74LS12**

SDLS040 TRIPLE 3-INPUT POSITIVE-NAND GATES WITH OPEN-COLLECTOR OUTPUTS

DECEMBER 1983—REVISED MARCH 1988

- Package Options Include Plastic "Small Outline" Packages, Ceramic Chip Carriers and Flat Packages, and Plastic and Ceramic DIPs
- Dependable Texas Instruments Quality and Reliability

description

These devices contain three independent 3-input NAND gates with open-collector outputs. The open-collector outputs require pull-up resistors to perform correctly. They may be connected to other open-collector outputs to implement active-low wired-OR or active-high wired-AND functions. Open-collector devices are often used to generate higher V_{OH} levels.

The SN5412 and SN54LS12 are characterized for operation over the full military temperature range of -55°C to 125°C . The SN7412 and SN74LS12 are characterized for operation from 0°C to 70°C .

FUNCTION TABLE (each gate)

| INPUTS | | | OUTPUT |
|--------|---|---|--------|
| A | B | C | Y |
| H | H | H | L |
| L | X | X | H |
| X | L | X | H |
| X | X | L | H |

logic symbol†

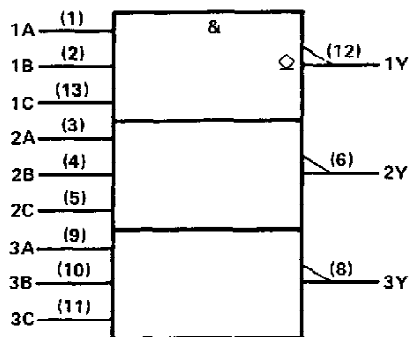

† This symbol is in accordance with ANSI/IEEE Std 91-1984 and IEC Publication 617-12.

Pin numbers shown are for D, J, N, and W packages.

SN5412, SN54LS12 . . . J OR W PACKAGE
SN7412 . . . N PACKAGE
SN74LS12 . . . D OR N PACKAGE

(TOP VIEW)

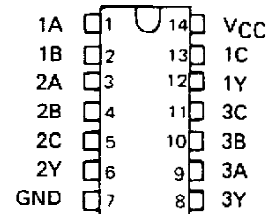

SN54LS12 . . . FK PACKAGE

(TOP VIEW)

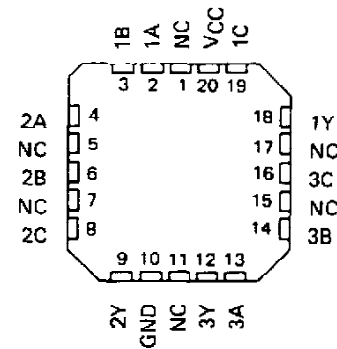

NC—No internal connection

logic diagram (positive logic)

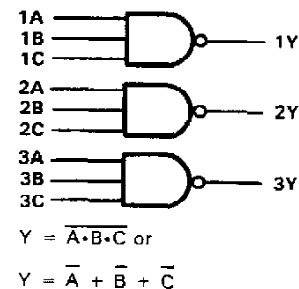

PRODUCTION DATA documents contain information current as of publication date. Products conform to specifications per the terms of Texas Instruments standard warranty. Production processing does not necessarily include testing of all parameters.



POST OFFICE BOX 655012 • DALLAS, TEXAS 75265

SN5412, SN54LS12
SN7412, SN74LS12
TRIPLE 3-INPUT POSITIVE-NAND GATES WITH OPEN-COLLECTOR OUTPUTS

schematics (each gate)

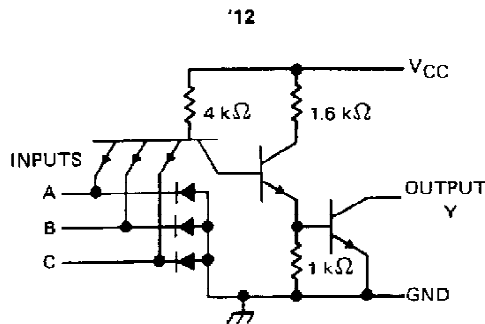

Resistor values shown are nominal.

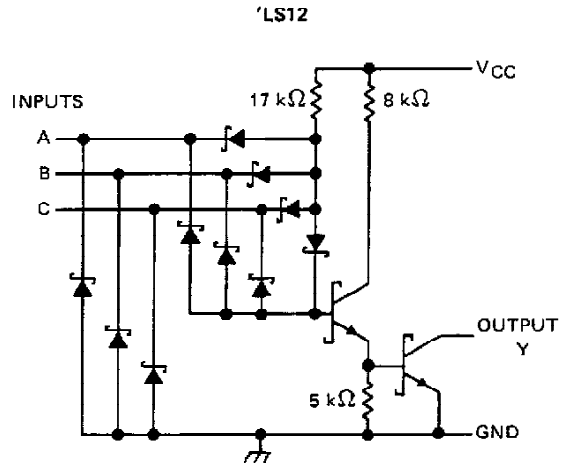

absolute maximum ratings over operating free-air temperature range (unless otherwise noted)

| | |
|---------------------------------------|----------------|
| Supply voltage, V_{CC} (see Note 1) | 7 V |
| Input voltage: '12 | 5.5 V |
| 'LS12 | 7 V |
| Off-state output voltage | 7 V |
| Operating free-air temperature: SN54' | -55°C to 125°C |
| SN74' | 0°C to 70°C |
| Storage temperature range | -65°C to 150°C |

NOTE 1: Voltage values are with respect to network ground terminal.

SN5412, SN5412

TRIPLE 3-INPUT POSITIVE-NAND GATES WITH OPEN-COLLECTOR OUTPUTS

recommended operating conditions

| | SN5412 | | | SN7412 | | | UNIT |
|---|--------|-----|-----|--------|-----|------|------|
| | MIN | NOM | MAX | MIN | NOM | MAX | |
| V _{CC} Supply voltage | 4.5 | 5 | 5.5 | 4.75 | 5 | 5.25 | V |
| V _{IH} High-level input voltage | 2 | | | 2 | | | V |
| V _{IL} Low-level input voltage | | | 0.8 | | | 0.8 | V |
| V _{OH} High-level output voltage | | | 5.5 | | | 5.5 | V |
| I _{OL} Low-level output current | | | 16 | | | 16 | mA |
| T _A Operating free-air temperature | -55 | | 125 | 0 | | 70 | °C |

electrical characteristics over recommended operating free-air temperature range (unless otherwise noted)

| PARAMETER | TEST CONDITIONS† | SN5412 | | | SN7412 | | | UNIT |
|------------------|---|--------|------|------|--------|------|------|------|
| | | MIN | TYP‡ | MAX | MIN | TYP‡ | MAX | |
| V _{IK} | V _{CC} = MIN, I _I = -12 mA | | | -1.5 | | | -1.5 | V |
| I _{OH} | V _{CC} = MIN, V _{IL} = 0.8 V, V _{OH} = 5.5 V | | | | | | 0.25 | mA |
| | V _{CC} = MIN, V _{IL} = 0.7 V, V _{OH} = 5.5 V | | | 0.25 | | | | |
| V _{OL} | V _{CC} = MIN, V _{IH} = 2 V, I _{OL} = 16 mA | | 0.2 | 0.4 | | 0.2 | 0.4 | V |
| I _I | V _{CC} = MAX, V _I = 5.5 V | | | 1 | | | 1 | mA |
| I _{IH} | V _{CC} = MAX, V _I = 2.4 V | | | 40 | | | 40 | μA |
| I _{IL} | V _{CC} = MAX, V _I = 0.4 V | | | -1.6 | | | -1.6 | mA |
| I _{CCH} | V _{CC} = MAX, V _I = 0 | | 3 | 6 | | 3 | 6 | mA |
| I _{CCL} | V _{CC} = MAX, V _I = 4.5 V | | 9 | 16.5 | | 9 | 16.5 | mA |

†For conditions shown as MIN or MAX, use the appropriate value specified under recommended operating conditions.

‡All typical values are at V_{CC} = 5 V, T_A = 25°C.

switching characteristics, V_{CC} = 5 V, T_A = 25°C (see note 2)

| PARAMETER | FROM (INPUT) | TO (OUTPUT) | TEST CONDITIONS | | MIN | TYP | MAX | UNIT |
|------------------|--------------|-------------|-------------------------|------------------------|-----|-----|-----|------|
| t _{PLH} | A, B or C | Y | R _L = 4 kΩ, | C _L = 15 pF | | 35 | 45 | ns |
| t _{PHL} | | | R _L = 400 Ω, | C _L = 15 pF | | 8 | 15 | ns |

NOTE 2: Load circuits and voltage waveforms are shown in Section 1.

TEXAS
INSTRUMENTS

POST OFFICE BOX 655012 • DALLAS, TEXAS 75265

SN54LS12, SN74LS12

TRIPLE 3-INPUT POSITIVE-NAND GATES WITH OPEN-COLLECTOR OUTPUTS

recommended operating conditions

| | SN54LS12 | | | SN74LS12 | | | UNIT |
|---|----------|-----|-----|----------|-----|------|------|
| | MIN | NOM | MAX | MIN | NOM | MAX | |
| V _{CC} Supply voltage | 4.5 | 5 | 5.5 | 4.75 | 5 | 5.25 | V |
| V _{IH} High-level input voltage | 2 | | | 2 | | | V |
| V _{IL} Low-level input voltage | | | 0.7 | | | 0.8 | V |
| V _{OH} High-level output voltage | | | 5.5 | | | 5.5 | V |
| I _{OL} Low-level output current | | | 4 | | | 8 | mA |
| T _A Operating free-air temperature | -55 | | 125 | 0 | | 70 | °C |

electrical characteristics over recommended operating free-air temperature range (unless otherwise noted)

| PARAMETER | TEST CONDITIONS † | SN54LS12 | | | SN74LS12 | | | UNIT |
|-------------------|---|----------|-------|------|----------|-------|------|------|
| | | MIN | TYP ‡ | MAX | MIN | TYP ‡ | MAX | |
| V _{IK} | V _{CC} = MIN, I _I = -18 mA | | -1.5 | | | -1.5 | | V |
| I _{OH} | V _{CC} = MIN, V _{IL} = MAX, V _{OH} = 5.5 V | | | 0.1 | | | 0.1 | mA |
| V _{OL} | V _{CC} = MIN, V _{IH} = 2 V, I _{OL} = 4 mA | | 0.25 | 0.4 | | 0.25 | 0.4 | V |
| | V _{CC} = MIN, V _{IH} = 2 V, I _{OL} = 8 mA | | | | | 0.35 | 0.5 | |
| I _I | V _{CC} = MAX, V _I = 7 V | | | 0.1 | | | 0.1 | mA |
| I _{IH} | V _{CC} = MAX, V _I = 2.7 V | | | 20 | | | 20 | μA |
| I _{IL} | V _{CC} = MAX, V _I = 0.4 V | | | -0.4 | | | -0.4 | mA |
| I _{CC} H | V _{CC} = MAX, V _I = 0 | | 0.7 | 1.4 | | 0.7 | 1.4 | mA |
| I _{CC} L | V _{CC} = MAX, V _I = 4.5 V | | 1.8 | 3.3 | | 1.8 | 3.3 | mA |

† For conditions shown as MIN or MAX, use the appropriate value specified under recommended operating conditions.

‡ All typical values are at V_{CC} = 5 V, T_A = 25°C.

switching characteristics, V_{CC} = 5 V, T_A = 25°C (see note 2)

| PARAMETER | FROM (INPUT) | TO (OUTPUT) | TEST CONDITIONS | MIN | TYP | MAX | UNIT |
|------------------|--------------|-------------|---|-----|-----|-----|------|
| t _{PLH} | A, B or C | Y | R _L = 2 kΩ, C _L = 15 pF | | 17 | 32 | ns |
| t _{PHL} | | | | | 15 | 28 | ns |

NOTE 2: Load circuits and voltage waveforms are shown in Section 1.

TEXAS
INSTRUMENTS

POST OFFICE BOX 655012 • DALLAS, TEXAS 75265

IMPORTANT NOTICE

Texas Instruments (TI) reserves the right to make changes to its products or to discontinue any semiconductor product or service without notice, and advises its customers to obtain the latest version of relevant information to verify, before placing orders, that the information being relied on is current.

TI warrants performance of its semiconductor products and related software to the specifications applicable at the time of sale in accordance with TI's standard warranty. Testing and other quality control techniques are utilized to the extent TI deems necessary to support this warranty. Specific testing of all parameters of each device is not necessarily performed, except those mandated by government requirements.

Certain applications using semiconductor products may involve potential risks of death, personal injury, or severe property or environmental damage ("Critical Applications").

TI SEMICONDUCTOR PRODUCTS ARE NOT DESIGNED, INTENDED, AUTHORIZED, OR WARRANTED TO BE SUITABLE FOR USE IN LIFE-SUPPORT APPLICATIONS, DEVICES OR SYSTEMS OR OTHER CRITICAL APPLICATIONS.

Inclusion of TI products in such applications is understood to be fully at the risk of the customer. Use of TI products in such applications requires the written approval of an appropriate TI officer. Questions concerning potential risk applications should be directed to TI through a local SC sales office.

In order to minimize risks associated with the customer's applications, adequate design and operating safeguards should be provided by the customer to minimize inherent or procedural hazards.

TI assumes no liability for applications assistance, customer product design, software performance, or infringement of patents or services described herein. Nor does TI warrant or represent that any license, either express or implied, is granted under any patent right, copyright, mask work right, or other intellectual property right of TI covering or relating to any combination, machine, or process in which such semiconductor products or services might be or are used.

PACKAGING INFORMATION

| Orderable Device | Status ⁽¹⁾ | Package Type | Package Drawing | Pins | Package Qty | Eco Plan ⁽²⁾ | Lead/Ball Finish | MSL Peak Temp ⁽³⁾ |
|------------------|-----------------------|--------------|-----------------|------|-------------|-------------------------|------------------|------------------------------|
| SN5412J | OBSOLETE | CDIP | J | 14 | | TBD | Call TI | Call TI |
| SN7412N | OBSOLETE | PDIP | N | 14 | | TBD | Call TI | Call TI |
| SN7412N | OBSOLETE | PDIP | N | 14 | | TBD | Call TI | Call TI |
| SN74LS12D | OBSOLETE | SOIC | D | 14 | | TBD | Call TI | Call TI |
| SN74LS12D | OBSOLETE | SOIC | D | 14 | | TBD | Call TI | Call TI |
| SN74LS12DR | OBSOLETE | SOIC | D | 14 | | TBD | Call TI | Call TI |
| SN74LS12DR | OBSOLETE | SOIC | D | 14 | | TBD | Call TI | Call TI |
| SN74LS12N | OBSOLETE | PDIP | N | 14 | | TBD | Call TI | Call TI |
| SN74LS12N | OBSOLETE | PDIP | N | 14 | | TBD | Call TI | Call TI |
| SN74LS12N3 | OBSOLETE | PDIP | N | 14 | | TBD | Call TI | Call TI |
| SN74LS12N3 | OBSOLETE | PDIP | N | 14 | | TBD | Call TI | Call TI |
| SNJ5412J | OBSOLETE | CDIP | J | 14 | | TBD | Call TI | Call TI |
| SNJ5412J | OBSOLETE | CDIP | J | 14 | | TBD | Call TI | Call TI |
| SNJ5412W | OBSOLETE | CFP | W | 14 | | TBD | Call TI | Call TI |
| SNJ5412W | OBSOLETE | CFP | W | 14 | | TBD | Call TI | Call TI |

⁽¹⁾ The marketing status values are defined as follows:

ACTIVE: Product device recommended for new designs.

LIFEBUY: TI has announced that the device will be discontinued, and a lifetime-buy period is in effect.

NRND: Not recommended for new designs. Device is in production to support existing customers, but TI does not recommend using this part in a new design.

PREVIEW: Device has been announced but is not in production. Samples may or may not be available.

OBSOLETE: TI has discontinued the production of the device.

⁽²⁾ Eco Plan - The planned eco-friendly classification: Pb-Free (RoHS) or Green (RoHS & no Sb/Br) - please check <http://www.ti.com/productcontent> for the latest availability information and additional product content details.

TBD: The Pb-Free/Green conversion plan has not been defined.

Pb-Free (RoHS): TI's terms "Lead-Free" or "Pb-Free" mean semiconductor products that are compatible with the current RoHS requirements for all 6 substances, including the requirement that lead not exceed 0.1% by weight in homogeneous materials. Where designed to be soldered at high temperatures, TI Pb-Free products are suitable for use in specified lead-free processes.

Green (RoHS & no Sb/Br): TI defines "Green" to mean Pb-Free (RoHS compatible), and free of Bromine (Br) and Antimony (Sb) based flame retardants (Br or Sb do not exceed 0.1% by weight in homogeneous material)

⁽³⁾ MSL, Peak Temp. -- The Moisture Sensitivity Level rating according to the JEDEC industry standard classifications, and peak solder temperature.

Important Information and Disclaimer:The information provided on this page represents TI's knowledge and belief as of the date that it is provided. TI bases its knowledge and belief on information provided by third parties, and makes no representation or warranty as to the accuracy of such information. Efforts are underway to better integrate information from third parties. TI has taken and continues to take reasonable steps to provide representative and accurate information but may not have conducted destructive testing or chemical analysis on incoming materials and chemicals. TI and TI suppliers consider certain information to be proprietary, and thus CAS numbers and other limited information may not be available for release.

In no event shall TI's liability arising out of such information exceed the total purchase price of the TI part(s) at issue in this document sold by TI to Customer on an annual basis.

J (R-GDIP-T**)

14 LEADS SHOWN

CERAMIC DUAL IN-LINE PACKAGE



| DIM \ PINS ** | 14 | 16 | 18 | 20 |
|---------------|------------------------|------------------------|------------------------|------------------------|
| A | 0.300 (7,62) BSC | 0.300 (7,62) BSC | 0.300 (7,62) BSC | 0.300 (7,62) BSC |
| B MAX | 0.785 (19,94) | .840 (21,34) | 0.960 (24,38) | 1.060 (26,92) |
| B MIN | — | — | — | — |
| C MAX | 0.300 (7,62) | 0.300 (7,62) | 0.310 (7,87) | 0.300 (7,62) |
| C MIN | 0.245 (6,22) | 0.245 (6,22) | 0.220 (5,59) | 0.245 (6,22) |



4040083/F 03/03

- NOTES:
- All linear dimensions are in inches (millimeters).
 - This drawing is subject to change without notice.
 - This package is hermetically sealed with a ceramic lid using glass frit.
 - Index point is provided on cap for terminal identification only on press ceramic glass frit seal only.
 - Falls within MIL STD 1835 GDIP1-T14, GDIP1-T16, GDIP1-T18 and GDIP1-T20.

W (R-GDFP-F14)

CERAMIC DUAL FLATPACK



- NOTES:
- A. All linear dimensions are in inches (millimeters).
 - B. This drawing is subject to change without notice.
 - C. This package can be hermetically sealed with a ceramic lid using glass frit.
 - D. Index point is provided on cap for terminal identification only.
 - E. Falls within MIL STD 1835 GDFP1-F14 and JEDEC MO-092AB

N (R-PDIP-T**)

PLASTIC DUAL-IN-LINE PACKAGE

16 PINS SHOWN

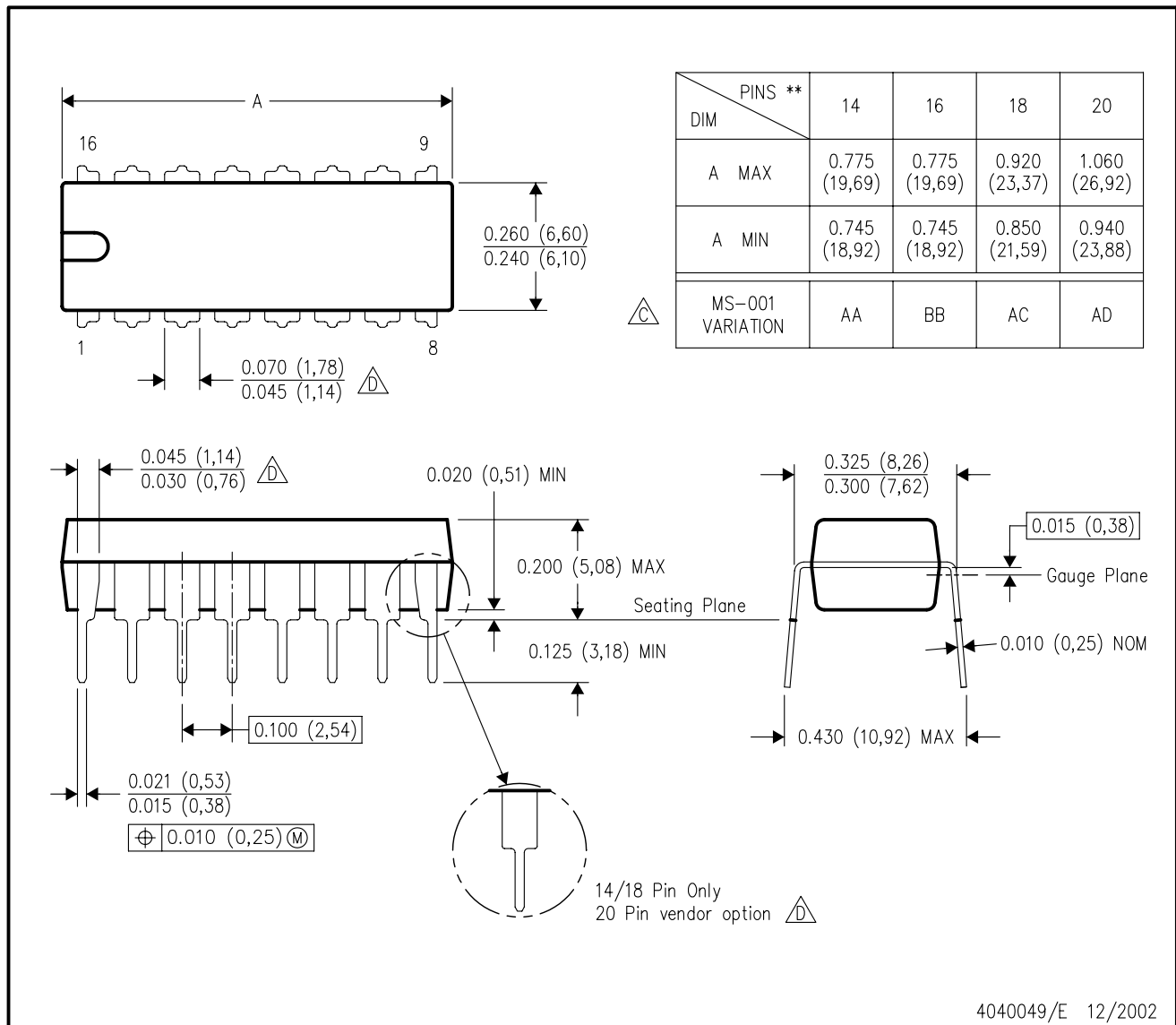

- NOTES:
- A. All linear dimensions are in inches (millimeters).
 - B. This drawing is subject to change without notice.
 - $\triangle C$ Falls within JEDEC MS-001, except 18 and 20 pin minimum body length (Dim A).
 - $\triangle D$ The 20 pin end lead shoulder width is a vendor option, either half or full width.

4040049/E 12/2002

D (R-PDSO-G14)

PLASTIC SMALL-OUTLINE PACKAGE

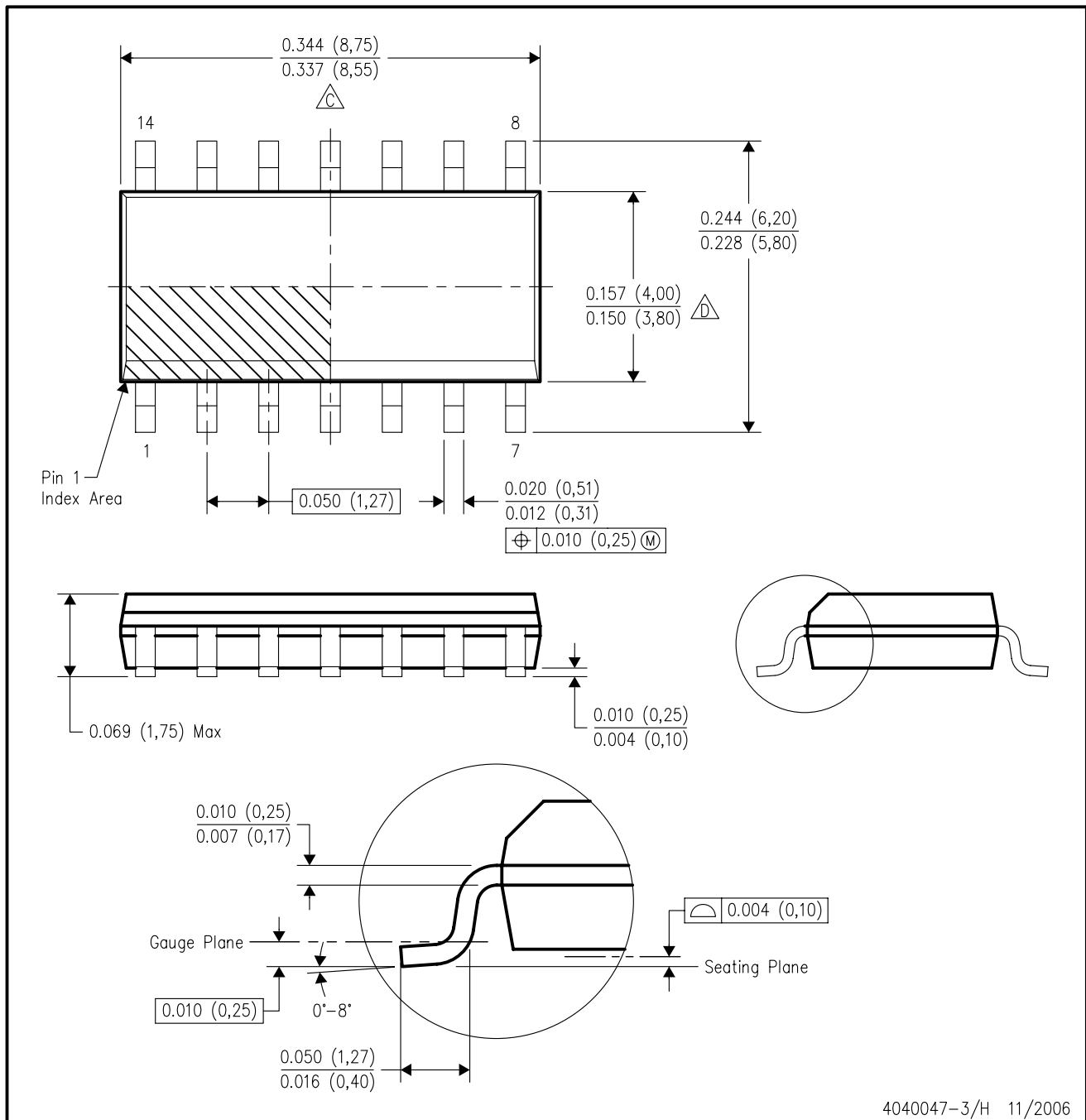

- NOTES:
- A. All linear dimensions are in inches (millimeters).
 - B. This drawing is subject to change without notice.
 - C. Body length does not include mold flash, protrusions, or gate burrs. Mold flash, protrusions, or gate burrs shall not exceed .006 (0,15) per end.
 - D. Body width does not include interlead flash. Interlead flash shall not exceed .017 (0,43) per side.
 - E. Reference JEDEC MS-012 variation AB.

IMPORTANT NOTICE

Texas Instruments Incorporated and its subsidiaries (TI) reserve the right to make corrections, modifications, enhancements, improvements, and other changes to its products and services at any time and to discontinue any product or service without notice. Customers should obtain the latest relevant information before placing orders and should verify that such information is current and complete. All products are sold subject to TI's terms and conditions of sale supplied at the time of order acknowledgment.

TI warrants performance of its hardware products to the specifications applicable at the time of sale in accordance with TI's standard warranty. Testing and other quality control techniques are used to the extent TI deems necessary to support this warranty. Except where mandated by government requirements, testing of all parameters of each product is not necessarily performed.

TI assumes no liability for applications assistance or customer product design. Customers are responsible for their products and applications using TI components. To minimize the risks associated with customer products and applications, customers should provide adequate design and operating safeguards.

TI does not warrant or represent that any license, either express or implied, is granted under any TI patent right, copyright, mask work right, or other TI intellectual property right relating to any combination, machine, or process in which TI products or services are used. Information published by TI regarding third-party products or services does not constitute a license from TI to use such products or services or a warranty or endorsement thereof. Use of such information may require a license from a third party under the patents or other intellectual property of the third party, or a license from TI under the patents or other intellectual property of TI.

Reproduction of information in TI data books or data sheets is permissible only if reproduction is without alteration and is accompanied by all associated warranties, conditions, limitations, and notices. Reproduction of this information with alteration is an unfair and deceptive business practice. TI is not responsible or liable for such altered documentation.

Resale of TI products or services with statements different from or beyond the parameters stated by TI for that product or service voids all express and any implied warranties for the associated TI product or service and is an unfair and deceptive business practice. TI is not responsible or liable for any such statements.

Following are URLs where you can obtain information on other Texas Instruments products and application solutions:

| Products | | Applications | |
|--------------------|--|---------------------|--|
| Amplifiers | amplifier.ti.com | Audio | www.ti.com/audio |
| Data Converters | dataconverter.ti.com | Automotive | www.ti.com/automotive |
| DSP | dsp.ti.com | Broadband | www.ti.com/broadband |
| Interface | interface.ti.com | Digital Control | www.ti.com/digitalcontrol |
| Logic | logic.ti.com | Military | www.ti.com/military |
| Power Mgmt | power.ti.com | Optical Networking | www.ti.com/opticalnetwork |
| Microcontrollers | microcontroller.ti.com | Security | www.ti.com/security |
| Low Power Wireless | www.ti.com/lpw | Telephony | www.ti.com/telephony |
| | | Video & Imaging | www.ti.com/video |
| | | Wireless | www.ti.com/wireless |

Mailing Address: Texas Instruments
Post Office Box 655303 Dallas, Texas 75265