



## MULTIPOINT-LVDS LINE DRIVER AND RECEIVER

### FEATURES

- Low-Voltage Differential 30- $\Omega$  to 55- $\Omega$  Line Drivers and Receivers for Signaling Rates<sup>(1)</sup> Up to 100 Mbps, Clock Frequencies up to 50 MHz
- Type-1 Receivers Incorporate 25 mV of Hysteresis (200A, 202A)
- Type-2 Receivers Provide an Offset (100 mV) Threshold to Detect Open-Circuit and Idle-Bus Conditions (204A, 205A)
- Meets or Exceeds the M-LVDS Standard TIA/EIA-899 for Multipoint Data Interchange
- Power Up/Down Glitch Free
- Controlled Driver Output Voltage Transition Times for Improved Signal Quality
- -1 V to 3.4 V Common-Mode Voltage Range Allows Data Transfer With 2 V of Ground Noise
- Bus Pins High Impedance When Disabled or  $V_{CC} \leq 1.5$  V
- 200-Mbps Devices Available (SN65MLVD201, 203, 206, 207)
- Bus Pin ESD Protection Exceeds 8 kV
- Package in 8-Pin SOIC (200A, 204A) and 14-Pin SOIC (202A, 205A)
- Improved Alternatives to the SN65MLVD200, 202, 204, and 205

### APPLICATIONS

- Low-Power High-Speed Short-Reach Alternative to TIA/EIA-485
- Backplane or Cabled Multipoint Data and Clock Transmission

- Cellular Base Stations
- Central-Office Switches
- Network Switches and Routers

### DESCRIPTION

The SN65MLVD200A, 202A, 204A, and 205A are multipoint-low-voltage differential (M-LVDS) line drivers and receivers, which are optimized to operate at signaling rates up to 100 Mbps. All parts comply with the multipoint low-voltage differential signaling (M-LVDS) standard TIA/EIA-899. These circuits are similar to their TIA/EIA-644 standard compliant LVDS counterparts, with added features to address multipoint applications. The driver output has been designed to support multipoint buses presenting loads as low as 30  $\Omega$ , and incorporates controlled transition times to allow for stubs off of the backbone transmission line.

These devices have Type-1 and Type-2 receivers that detect the bus state with as little as 50 mV of differential input voltage over a common-mode voltage range of -1 V to 3.4 V. The Type-1 receivers exhibit 25 mV of differential input voltage hysteresis to prevent output oscillations with slowly changing signals or loss of input. Type-2 receivers include an offset threshold to provide a known output state under open-circuit, idle-bus, and other fault conditions.

The SN65MLVD200A, 202A, 204A, and 205A have enhancements over their predecessors. Improved features include better controlled slew rate on the driver output to help minimize reflections while improving overall signal integrity (SI) resulting in better jitter performance. Additionally, 8-kV ESD protection on the bus pins for more robustness. The same footprint definition was maintained making for an easy drop-in replacement for a system performance upgrade.

The devices are characterized for operation from -40°C to 85°C.



Please be aware that an important notice concerning availability, standard warranty, and use in critical applications of Texas Instruments semiconductor products and disclaimers thereto appears at the end of this data sheet.

<sup>(1)</sup>The signaling rate of a line, is the number of voltage transitions that are made per second expressed in the units bps (bits per second).

LOGIC DIAGRAM (POSITIVE LOGIC)

SN65MLVD200A, SN65MLVD204A

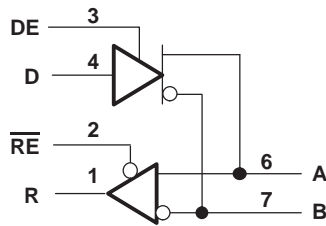

SN65MLVD202A, SN65MLVD205A

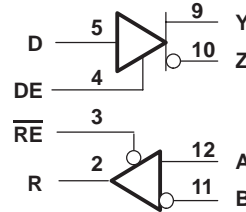

These devices have limited built-in ESD protection. The leads should be shorted together or the device placed in conductive foam during storage or handling to prevent electrostatic damage to the MOS gates.

ORDERING INFORMATION

PART NUMBER(1)	FOOTPRINT	RECEIVER TYPE	PACKAGE MARKING
SN65MLVD200AD	SN75176	Type 1	MF200A
SM65MLVD202AD	SN75ALS180	Type 1	MLVD202A
SN65MLVD204AD	SN75176	Type 2	MF204A
SM65MLVD205AD	SN75ALS180	Type 2	MLVD205A

(1) Available tape and reeled. To order a tape and reeled part, add the suffix R to the part number (e.g., SN65MLVD200ADR).

PACKAGE DISSIPATION RATINGS

PACKAGE	T <sub>A</sub> ≤ 25°C POWER RATING	DERATING FACTOR ABOVE T <sub>A</sub> = 25°C	T <sub>A</sub> = 85°C POWER RATING
D(8)	532 mW	4.6 mW/°C	254 mW
D(14)	940 mW	8.2 mW/°C	450 mW

ABSOLUTE MAXIMUM RATINGS

over operating free-air temperature range unless otherwise noted(1)

		SN65MLVD200A, 202A, 204A, AND 205A	
Supply voltage range(2), V <sub>CC</sub>		-0.5 V to 4 V	
Input voltage range	D, DE, RE	-0.5 V to 4 V	
	A, B (200A, 204A)	-1.8 V to 4 V	
	A, B (202A, 205A)	-4 V to 6 V	
Output voltage range	R	-0.3 V to 4 V	
	Y, Z, A, or B	-1.8 V to 4 V	
Electrostatic discharge	Human Body Model(3)	A, B, Y, and Z	±8 kV
		All pins	±4 kV
	Charged-Device Model(4)	All pins	±1500 V
Continuous power dissipation		See Dissipation Rating Table	
Storage temperature range		-65°C to 150°C	

(1) Stresses beyond those listed under "absolute maximum ratings" may cause permanent damage to the device. These are stress ratings only, and functional operation of the device at these or any other conditions beyond those indicated under "recommended operating conditions" is not implied. Exposure to absolute-maximum-rated conditions for extended periods may affect device reliability.

(2) All voltage values, except differential I/O bus voltages, are with respect to network ground terminal.

(3) Tested in accordance with JEDEC Standard 22, Test Method A114-A.

(4) Tested in accordance with JEDEC Standard 22, Test Method C101.

**RECOMMENDED OPERATING CONDITIONS**

	MIN	NOM	MAX	UNIT
Supply voltage, $V_{CC}$	3	3.3	3.6	V
High-level input voltage, $V_{IH}$	2		$V_{CC}$	V
Low-level input voltage, $V_{IL}$	GND		0.8	V
Voltage at any bus terminal $V_A, V_B, V_Y$ or $V_Z$	-1.4		3.8	V
Magnitude of differential input voltage, $M_{ID}$	0.05		$V_{CC}$	V
Differential load resistance, $R_L$	30	50		$\Omega$
Signaling rate, $1/t_{UJ}$			100	Mbps
Operating free-air temperature, $T_A$	-40		85	$^{\circ}\text{C}$

**DEVICE ELECTRICAL CHARACTERISTICS**

over recommended operating conditions unless otherwise noted

PARAMETER		TEST CONDITIONS	MIN	TYP(1)	MAX	UNIT	
$I_{CC}$	Supply current	Driver only	RE and DE at $V_{CC}$ , $R_L = 50 \Omega$ , All others open		13	22	mA
		Both disabled	RE at $V_{CC}$ , DE at 0 V, $R_L = \text{No Load}$ , All others open		1	4	
		Both enabled	RE at 0 V, DE at $V_{CC}$ , $R_L = 50 \Omega$ , All others open		16	24	
		Receiver only	RE at 0 V, DE at 0 V, All others open		4	13	
$P_D$	Device power dissipation	$R_L = 50 \Omega$ , Input to D is a 50-MHz 50% duty cycle square wave, DE = high, RE = low, $T_A = 85^{\circ}\text{C}$			94	mW	

 (1) All typical values are at  $25^{\circ}\text{C}$  and with a 3.3-V supply voltage.

**DRIVER ELECTRICAL CHARACTERISTICS**

over recommended operating conditions unless otherwise noted

PARAMETER	TEST CONDITIONS	MIN(1)	TYP(2)	MAX	UNIT	
$ V_{AB} $ or $ V_{YZ} $	Differential output voltage magnitude	See Figure 2		480	650	mV
$\Delta V_{AB} $ or $\Delta V_{YZ} $	Change in differential output voltage magnitude between logic states			-50	50	mV
$V_{OS(SS)}$	Steady-state common-mode output voltage	See Figure 3		0.8	1.2	V
$\Delta V_{OS(SS)}$	Change in steady-state common-mode output voltage between logic states			-50	50	mV
$V_{OS(PP)}$	Peak-to-peak common-mode output voltage				150	mV
$V_{Y(OC)}$ or $V_{A(OC)}$	Maximum steady-state open-circuit output voltage	See Figure 7		0	2.4	V
$V_{Z(OC)}$ or $V_{B(OC)}$	Maximum steady-state open-circuit output voltage			0	2.4	V
$V_{P(H)}$	Voltage overshoot, low-to-high level output	See Figure 5			$1.2V_{SS}$	V
$V_{P(L)}$	Voltage overshoot, high-to-low level output			$-0.2V_{SS}$		V
$I_{IH}$	High-level input current (D, DE)	$V_{IH} = 2V$ to $V_{CC}$		0	10	$\mu A$
$I_{IL}$	Low-level input current (D, DE)	$V_{IL} = GND$ to $0.8V$		0	10	$\mu A$
$ I_{OS} $	Differential short-circuit output current magnitude	See Figure 4			24	mA
$I_{OZ}$	High-impedance state output current (driver only)	$-1.4V \leq (V_Y \text{ or } V_Z) \leq 3.8V$ , Other output = $1.2V$		-15	10	$\mu A$
$I_{O(OFF)}$	Power-off output current	$-1.4V \leq (V_Y \text{ or } V_Z) \leq 3.8V$ , Other output = $1.2V$ , $0V \leq V_{CC} \leq 1.5V$		-10	10	$\mu A$
$C_Y$ or $C_Z$	Output capacitance	$V_I = 0.4 \sin(30E6\pi t) + 0.5V$ , (3) Other input at $1.2V$ , driver disabled			3	pF
$C_{YZ}$	Differential output capacitance	$V_{AB} = 0.4 \sin(30E6\pi t)V$ , (3) Driver disabled			2.5	pF
$C_{Y/Z}$	Output capacitance balance, ( $C_Y/C_Z$ )			0.99	1.01	

(1) The algebraic convention, in which the least positive (most negative) limit is designated as minimum is used in this data sheet.

(2) All typical values are at 25°C and with a 3.3-V supply voltage.

(3) HP4194A impedance analyzer (or equivalent)

**RECEIVER ELECTRICAL CHARACTERISTICS**

 over recommended operating conditions unless otherwise noted<sup>(1)</sup>

PARAMETER		TEST CONDITIONS	MIN	TYP <sup>(1)</sup>	MAX	UNIT
V <sub>IT+</sub>	Positive-going differential input voltage threshold	Type 1			50	mV
		Type 2			150	
V <sub>IT-</sub>	Negative-going differential input voltage threshold	Type 1	See Figure 9 and Table 1 and Table 2		-50	mV
		Type 2			50	
V <sub>HYS</sub>	Differential input voltage hysteresis, (V <sub>IT+</sub> - V <sub>IT-</sub> )	Type 1			25	mV
		Type 2			0	
V <sub>OH</sub>	High-level output voltage	I <sub>OH</sub> = -8 mA	2.4			V
V <sub>OL</sub>	Low-level output voltage	I <sub>OL</sub> = 8 mA			0.4	V
I <sub>IH</sub>	High-level input current ( $\overline{RE}$ )	V <sub>IH</sub> = 2 V to V <sub>CC</sub>	-10		0	μA
I <sub>IL</sub>	Low-level input current ( $\overline{RE}$ )	V <sub>IL</sub> = GND to 0.8 V	-10		0	μA
I <sub>OZ</sub>	High-impedance output current	V <sub>O</sub> = 0 V or 3.6 V	-10		15	μA
C <sub>A</sub> or C <sub>B</sub>	Input capacitance	V <sub>I</sub> = 0.4 sin(30E6πt) + 0.5 V, <sup>(2)</sup> Other input at 1.2 V		3		pF
C <sub>AB</sub>	Differential input capacitance	V <sub>AB</sub> = 0.4 sin(30E6πt) V <sup>(2)</sup>			2.5	pF
C <sub>A/B</sub>	Input capacitance balance, (C <sub>A</sub> /C <sub>B</sub> )		0.99		1.01	

<sup>(1)</sup> All typical values are at 25°C and with a 3.3-V supply voltage.

<sup>(2)</sup> HP4194A impedance analyzer (or equivalent)

**BUS INPUT AND OUTPUT ELECTRICAL CHARACTERISTICS**

over recommended operating conditions unless otherwise noted

PARAMETER		TEST CONDITIONS	MIN	TYP <sup>(1)</sup>	MAX	UNIT
I <sub>A</sub>	Receiver or transceiver with driver disabled input current	V <sub>A</sub> = 3.8 V, V <sub>B</sub> = 1.2 V,	0		32	μA
		V <sub>A</sub> = 0 V or 2.4 V, V <sub>B</sub> = 1.2 V	-20		20	
		V <sub>A</sub> = -1.4 V, V <sub>B</sub> = 1.2 V	-32		0	
I <sub>B</sub>	Receiver or transceiver with driver disabled input current	V <sub>B</sub> = 3.8 V, V <sub>A</sub> = 1.2 V	0		32	μA
		V <sub>B</sub> = 0 V or 2.4 V, V <sub>A</sub> = 1.2 V	-20		20	
		V <sub>B</sub> = -1.4 V, V <sub>A</sub> = 1.2 V	-32		0	
I <sub>AB</sub>	Receiver or transceiver with driver disabled differential input current (I <sub>A</sub> - I <sub>B</sub> )	V <sub>A</sub> = V <sub>B</sub> , -1.4 ≤ V <sub>A</sub> ≤ 3.8 V	-4		4	μA
I <sub>A(OFF)</sub>	Receiver or transceiver power-off input current	V <sub>A</sub> = 3.8 V, V <sub>B</sub> = 1.2 V, 0 V ≤ V <sub>CC</sub> ≤ 1.5 V	0		32	μA
		V <sub>A</sub> = 0 V or 2.4 V, V <sub>B</sub> = 1.2 V, 0 V ≤ V <sub>CC</sub> ≤ 1.5 V	-20		20	
		V <sub>A</sub> = -1.4 V, V <sub>B</sub> = 1.2 V, 0 V ≤ V <sub>CC</sub> ≤ 1.5 V	-32		0	
I <sub>B(OFF)</sub>	Receiver or transceiver power-off input current	V <sub>B</sub> = 3.8 V, V <sub>A</sub> = 1.2 V, 0 V ≤ V <sub>CC</sub> ≤ 1.5 V	0		32	μA
		V <sub>B</sub> = 0 V or 2.4 V, V <sub>A</sub> = 1.2 V, 0 V ≤ V <sub>CC</sub> ≤ 1.5 V	-20		20	
		V <sub>B</sub> = -1.4 V, V <sub>A</sub> = 1.2 V, 0 V ≤ V <sub>CC</sub> ≤ 1.5 V	-32		0	
I <sub>AB(OFF)</sub>	Receiver input or transceiver power-off differential input current (I <sub>A</sub> - I <sub>B</sub> )	V <sub>A</sub> = V <sub>B</sub> , 0 V ≤ V <sub>CC</sub> ≤ 1.5 V, -1.4 ≤ V <sub>A</sub> ≤ 3.8 V	-4		4	μA
C <sub>A</sub>	Transceiver with driver disabled input capacitance	V <sub>A</sub> = 0.4 sin(30E6πt) + 0.5V <sup>(2)</sup> , V <sub>B</sub> = 1.2 V		5		pF
C <sub>B</sub>	Transceiver with driver disabled input capacitance	V <sub>B</sub> = 0.4 sin(30E6πt) + 0.5V <sup>(2)</sup> , V <sub>A</sub> = 1.2 V		5		pF

<sup>(1)</sup> All typical values are at 25°C and with a 3.3-V supply voltage.

<sup>(2)</sup> HP4194A impedance analyzer (or equivalent)

**BUS INPUT AND OUTPUT ELECTRICAL CHARACTERISTICS (continued)**

PARAMETER		TEST CONDITIONS	MIN	TYP(1)	MAX	UNIT
C <sub>AB</sub>	Transceiver with driver disabled differential input capacitance	V <sub>AB</sub> = 0.4 sin (30E6πt)V (2)			3	pF
C <sub>A/B</sub>	Transceiver with driver disabled input capacitance balance, (C <sub>A</sub> /C <sub>B</sub> )		0.99		1.01	

(1) All typical values are at 25°C and with a 3.3-V supply voltage.

(2) HP4194A impedance analyzer (or equivalent)

**DRIVER SWITCHING CHARACTERISTICS**

over recommended operating conditions unless otherwise noted

PARAMETER		TEST CONDITIONS	MIN	TYP(1)	MAX	UNIT
t <sub>pLH</sub>	Propagation delay time, low-to-high-level output	See Figure 5	2	2.5	3.5	ns
t <sub>pHL</sub>	Propagation delay time, high-to-low-level output		2	2.5	3.5	ns
t <sub>r</sub>	Differential output signal rise time		2	2.6	3.2	ns
t <sub>f</sub>	Differential output signal fall time		2	2.6	3.2	ns
t <sub>sk(p)</sub>	Pulse skew ( t <sub>pHL</sub> - t <sub>pLH</sub>  )			30	150	ps
t <sub>sk(pp)</sub>	Part-to-part skew				0.9	ns
t <sub>jit(per)</sub>	Period jitter, rms (1 standard deviation) (2)	50 MHz clock input(3)		2	3	ps
t <sub>jit(pp)</sub>	Peak-to-peak jitter(2)(5)	100 Mbps 2 <sup>15</sup> -1 PRBS input(4)		55	150	ps
t <sub>pHZ</sub>	Disable time, high-level-to-high-impedance output	See Figure 6		4	7	ns
t <sub>pLZ</sub>	Disable time, low-level-to-high-impedance output			4	7	ns
t <sub>pZH</sub>	Enable time, high-impedance-to-high-level output			4	7	ns
t <sub>pZL</sub>	Enable time, high-impedance-to-low-level output			4	7	ns

(1) All typical values are at 25°C and with a 3.3-V supply voltage.

(2) Jitter is ensured by design and characterization. Stimulus jitter has been subtracted from the numbers.

(3) t<sub>r</sub> = t<sub>f</sub> = 0.5 ns (10% to 90%), measured over 30 k samples.

(4) t<sub>r</sub> = t<sub>f</sub> = 0.5 ns (10% to 90%), measured over 100 k samples.

(5) Peak-to-peak jitter includes jitter due to pulse skew (t<sub>sk(p)</sub>).

**RECEIVER SWITCHING CHARACTERISTICS**

over recommended operating conditions unless otherwise noted

PARAMETER		TEST CONDITIONS	MIN	TYP(1)	MAX	UNIT	
t <sub>pLH</sub>	Propagation delay time, low-to-high-level output	C <sub>L</sub> = 15 pF, See Figure 10	2	3.6	6	ns	
t <sub>pHL</sub>	Propagation delay time, high-to-low-level output		2	3.6	6	ns	
t <sub>r</sub>	Output signal rise time		1		2.3	ns	
t <sub>f</sub>	Output signal fall time		1		2.3	ns	
t <sub>sk(p)</sub>	Pulse skew ( t <sub>pHL</sub> - t <sub>pLH</sub>  )		Type 1		100	300	ps
			Type 2		300	500	ps
t <sub>sk(pp)</sub>	Part-to-part skew(2)			1	ns		
t <sub>jit(per)</sub>	Period jitter, rms (1 standard deviation) (3)	50 MHz clock input(4)		4	7	ps	
t <sub>jit(pp)</sub>	Peak-to-peak jitter(3)(6)	Type 1		200	700	ps	
		Type 2	100 Mbps 2 <sup>15</sup> -1 PRBS input(5)		225	800	ps
t <sub>pHZ</sub>	Disable time, high-level-to-high-impedance output	See Figure 11		6	10	ns	
t <sub>pLZ</sub>	Disable time, low-level-to-high-impedance output			6	10	ns	
t <sub>pZH</sub>	Enable time, high-impedance-to-high-level output			10	15	ns	
t <sub>pZL</sub>	Enable time, high-impedance-to-low-level output			10	15	ns	

(1) All typical values are at 25°C and with a 3.3-V supply voltage.

(2) HP4194A impedance analyzer (or equivalent)

(3) Jitter is ensured by design and characterization. Stimulus jitter has been subtracted from the numbers.

(4) V<sub>ID</sub> = 200 mV<sub>pp</sub> (LVD200A, 202A), V<sub>ID</sub> = 400 mV<sub>pp</sub> (LVD204A, 205A), V<sub>CM</sub> = 1 V, t<sub>r</sub> = t<sub>f</sub> = 0.5 ns (10% to 90%), measured over 30 k samples.

(5) V<sub>ID</sub> = 200 mV<sub>pp</sub> (LVD200A, 202A), V<sub>ID</sub> = 400 mV<sub>pp</sub> (LVD204A, 205A), V<sub>CM</sub> = 1 V, t<sub>r</sub> = t<sub>f</sub> = 0.5 ns (10% to 90%), measured over 100 k samples.

(6) Peak-to-peak jitter includes jitter due to pulse skew (t<sub>sk(p)</sub>).

PARAMETER MEASUREMENT INFORMATION

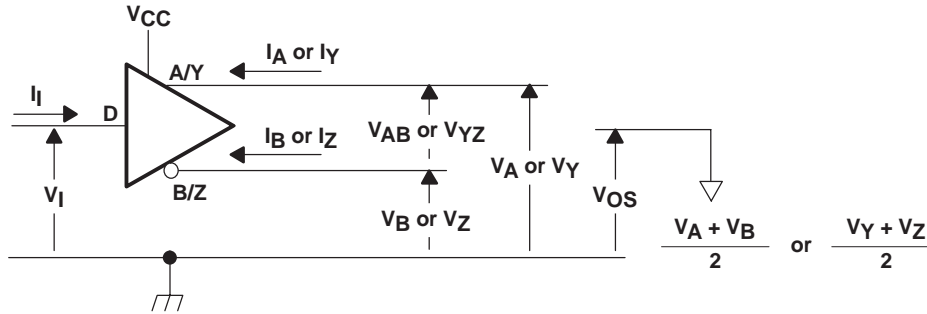
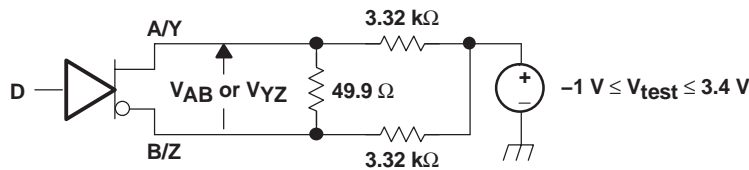
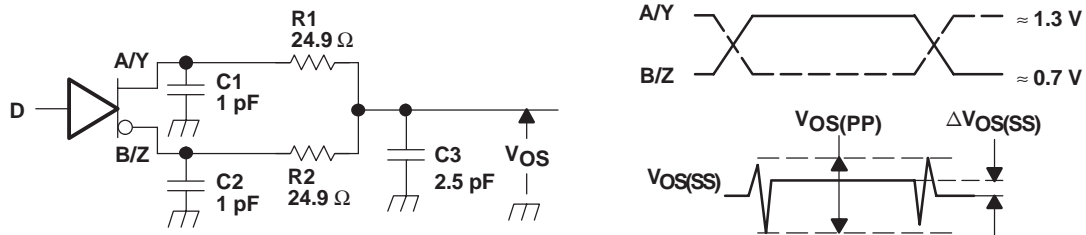

Figure 1. Driver Voltage and Current Definitions



NOTE: All resistors are 1% tolerance.

Figure 2. Differential Output Voltage Test Circuit



- NOTES:A. All input pulses are supplied by a generator having the following characteristics:  $t_r$  or  $t_f \leq 1$  ns, pulse frequency = 1 MHz, duty cycle =  $50 \pm 5\%$ .  
 B. C1, C2 and C3 include instrumentation and fixture capacitance within 2 cm of the D.U.T. and are  $\pm 20\%$ .  
 C. R1 and R2 are metal film, surface mount,  $\pm 1\%$ , and located within 2 cm of the D.U.T.  
 D. The measurement of  $V_{OS(PP)}$  is made on test equipment with a  $-3$  dB bandwidth of at least 1 GHz.

Figure 3. Test Circuit and Definitions for the Driver Common-Mode Output Voltage

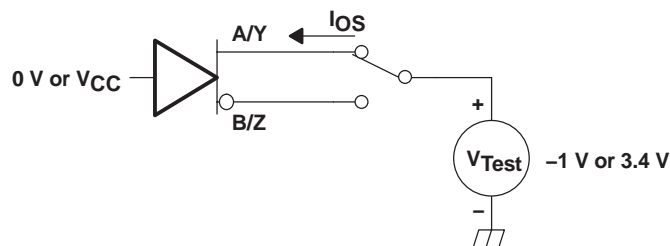
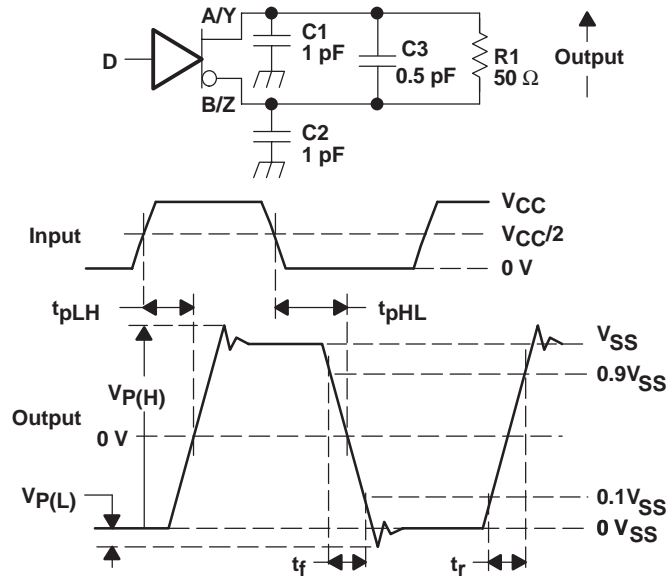
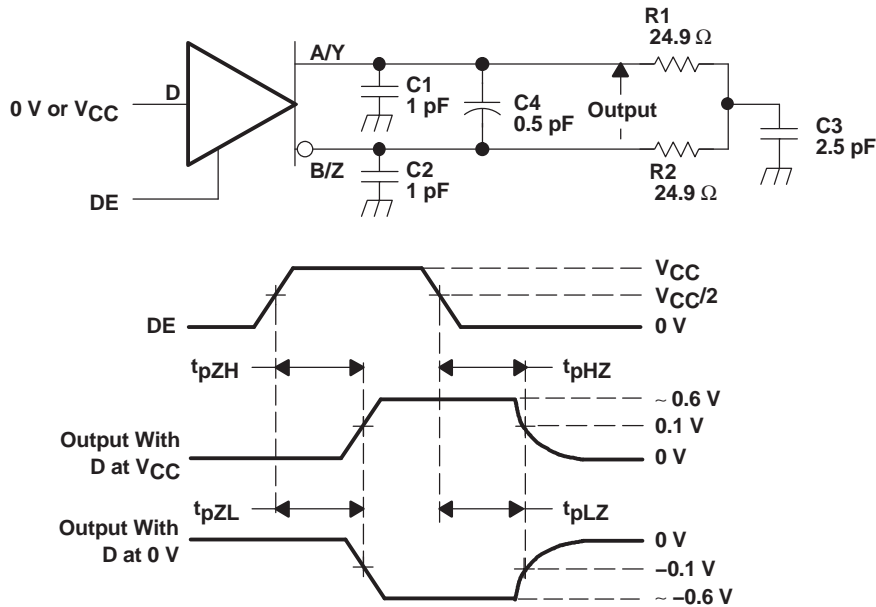

Figure 4. Driver Short-Circuit Test Circuit



- NOTES:A. All input pulses are supplied by a generator having the following characteristics:  $t_r$  or  $t_f \leq 1$  ns, frequency = 1 MHz, duty cycle =  $50 \pm 5\%$ .  
B. C1, C2, and C3 include instrumentation and fixture capacitance within 2 cm of the D.U.T. and are  $\pm 20\%$ .  
C. R1 is a metal film, surface mount, and 1% tolerance and located within 2 cm of the D.U.T.  
D. The measurement is made on test equipment with a  $-3$  dB bandwidth of at least 1 GHz.

Figure 5. Driver Test Circuit, Timing, and Voltage Definitions for the Differential Output Signal



- NOTES:A. All input pulses are supplied by a generator having the following characteristics:  $t_r$  or  $t_f \leq 1$  ns, frequency = 1 MHz, duty cycle =  $50 \pm 5\%$ .  
B. C1, C2, C3, and C4 includes instrumentation and fixture capacitance within 2 cm of the D.U.T. and are  $\pm 20\%$ .  
C. R1 and R2 are metal film, surface mount, and 1% tolerance and located within 2 cm of the D.U.T.  
D. The measurement is made on test equipment with a  $-3$  dB bandwidth of at least 1 GHz.

Figure 6. Driver Enable and Disable Time Circuit and Definitions

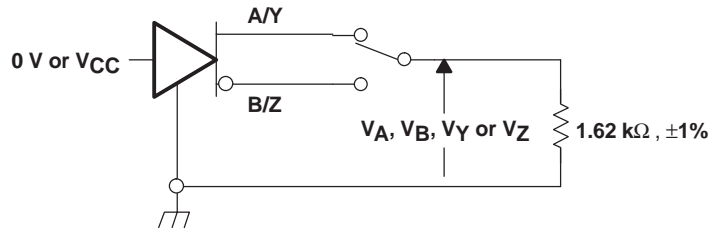
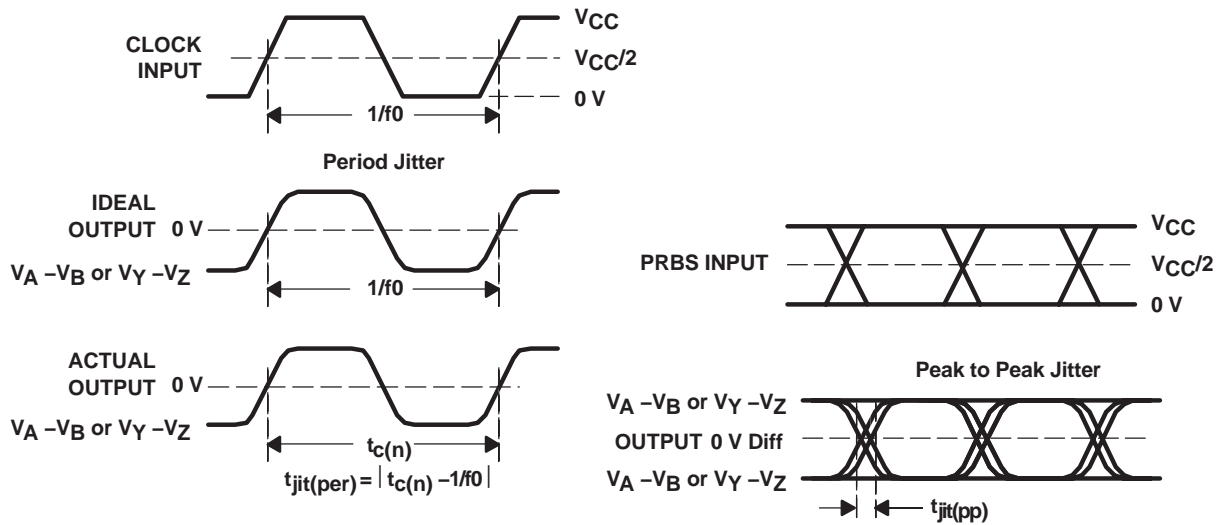

Figure 7. Maximum Steady State Output Voltage



- NOTES: A. All input pulses are supplied by an Agilent 81250 Stimulus System.  
 B. The measurement is made on a TEK TDS6604 running TDSJIT3 application software  
 C. Period jitter is measured using a 50 MHz 50 ±1% duty cycle clock input.  
 D. Peak-to-peak jitter is measured using a 100Mbps  $2^{15}-1$  PRBS input.

Figure 8. Driver Jitter Measurement Waveforms

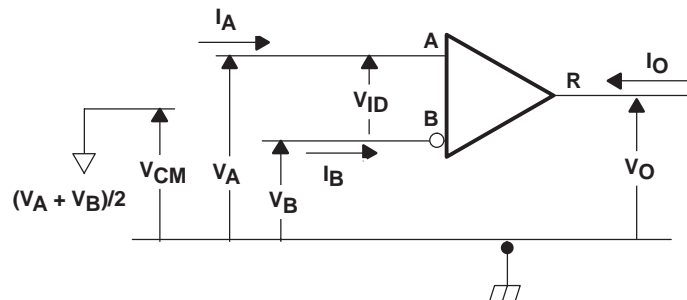

Figure 9. Receiver Voltage and Current Definitions

Table 1. Type-1 Receiver Input Threshold Test Voltages

APPLIED VOLTAGES		RESULTING DIFFERENTIAL INPUT VOLTAGE	RESULTING COMMON-MODE INPUT VOLTAGE	RECEIVER OUTPUT
V <sub>IA</sub>	V <sub>IB</sub>	V <sub>ID</sub>	V <sub>IC</sub>	
2.400	0.000	2.400	1.200	H
0.000	2.400	-2.400	1.200	L
3.425	3.335	0.050	3.4	H
3.375	3.425	-0.050	3.4	L
-0.975	-1.025	0.050	-1	H
-1.025	-0.975	-0.050	-1	L

NOTE: H= high level, L = low level, output state assumes receiver is enabled ( $\overline{RE} = L$ )

Table 2. Type-2 Receiver Input Threshold Test Voltages

APPLIED VOLTAGES		RESULTING DIFFERENTIAL INPUT VOLTAGE	RESULTING COMMON-MODE INPUT VOLTAGE	RECEIVER OUTPUT
V <sub>IA</sub>	V <sub>IB</sub>	V <sub>ID</sub>	V <sub>IC</sub>	
2.400	0.000	2.400	1.200	H
0.000	2.400	-2.400	1.200	L
3.475	3.325	0.150	3.4	H
3.425	3.375	0.050	3.4	L
-0.925	-1.075	0.150	-1	H
-0.975	-1.025	0.050	-1	L

NOTE: H= high level, L = low level, output state assumes receiver is enabled ( $\overline{RE} = L$ )

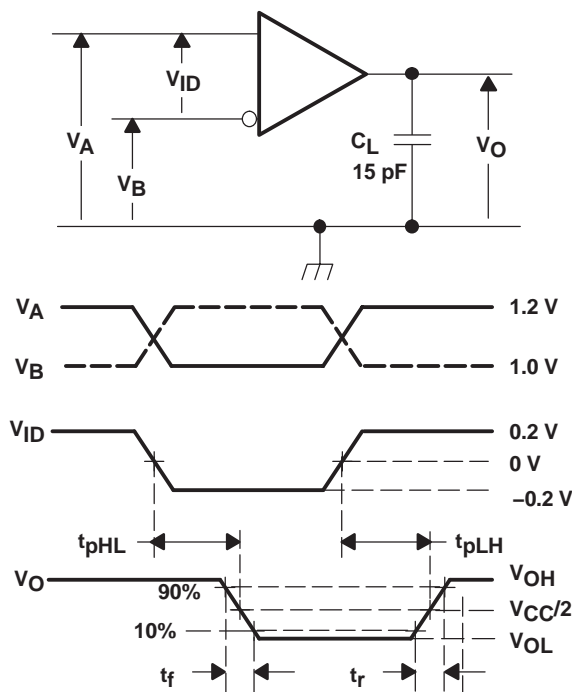

NOTES:A. All input pulses are supplied by a generator having the following characteristics:  $t_r$  or  $t_f \leq 1$  ns, frequency = 1 MHz, duty cycle =  $50 \pm 5\%$ .  
C<sub>L</sub> is a combination of a 20%-tolerance, low-loss ceramic, surface-mount capacitor and fixture capacitance within 2 cm of the D.U.T.  
B. The measurement is made on test equipment with a -3 dB bandwidth of at least 1 GHz.

Figure 10. Receiver Timing Test Circuit and Waveforms



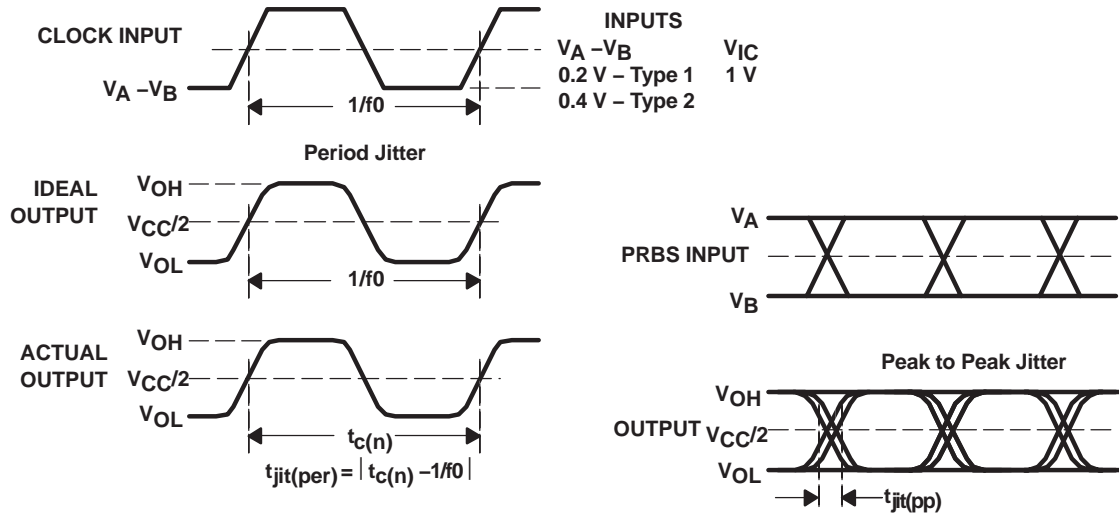

- NOTES: A. All input pulses are supplied by an Agilent 8304A Stimulus System.  
 B. The measurement is made on a TEK TDS6604 running TDSJIT3 application software  
 C. Period jitter is measured using a 50 MHz 50 ±1% duty cycle clock input.  
 D. Peak-to-peak jitter is measured using a 100 Mbps 2<sup>15</sup>-1 PRBS input.

Figure 12. Receiver Jitter Measurement Waveforms

PIN ASSIGNMENTS

SN65MLVD200AD (Marked as MF200A)  
SN65MLVD204AD (Marked as MF204A)  
(TOP VIEW)

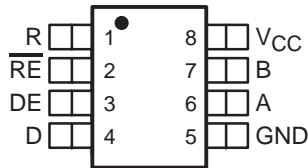

SN65MLVD202AD (Marked as MLVD202A)  
SN65MLVD205AD (Marked as MLVD205A)  
(TOP VIEW)

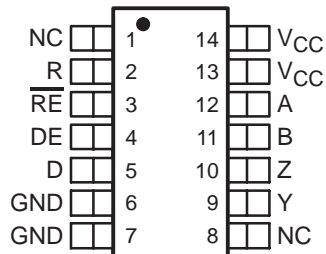

NC – No internal connection

DEVICE FUNCTION TABLE

TYPE-1 RECEIVER (200A, 202A)			TYPE-2 RECEIVER (204A, 205A)		
INPUTS		OUTPUT	INPUTS		OUTPUT
$V_{ID} = V_A - V_B$	$\overline{RE}$	R	$V_{ID} = V_A - V_B$	$\overline{RE}$	R
$V_{ID} \geq 50 \text{ mV}$	L	H	$V_{ID} \geq 150 \text{ mV}$	L	H
$-50 \text{ mV} < V_{ID} < 50 \text{ mV}$	L	?	$50 \text{ mV} < V_{ID} < 150 \text{ mV}$	L	?
$V_{ID} \leq -50 \text{ mV}$	L	L	$V_{ID} \leq 50 \text{ mV}$	L	L
X	H	Z	X	H	Z
X	Open	Z	X	Open	Z
Open Circuit	L	?	Open Circuit	L	L

DRIVER

INPUT	ENABLE	OUTPUTS	
D	DE	A OR Y	B OR Z
L	H	L	H
H	H	H	L
OPEN	H	L	H
X	OPEN	Z	Z
X	L	Z	Z

H = high level, L = low level, Z = high impedance, X = Don't care, ? = indeterminate

EQUIVALENT INPUT AND OUTPUT SCHEMATIC DIAGRAMS

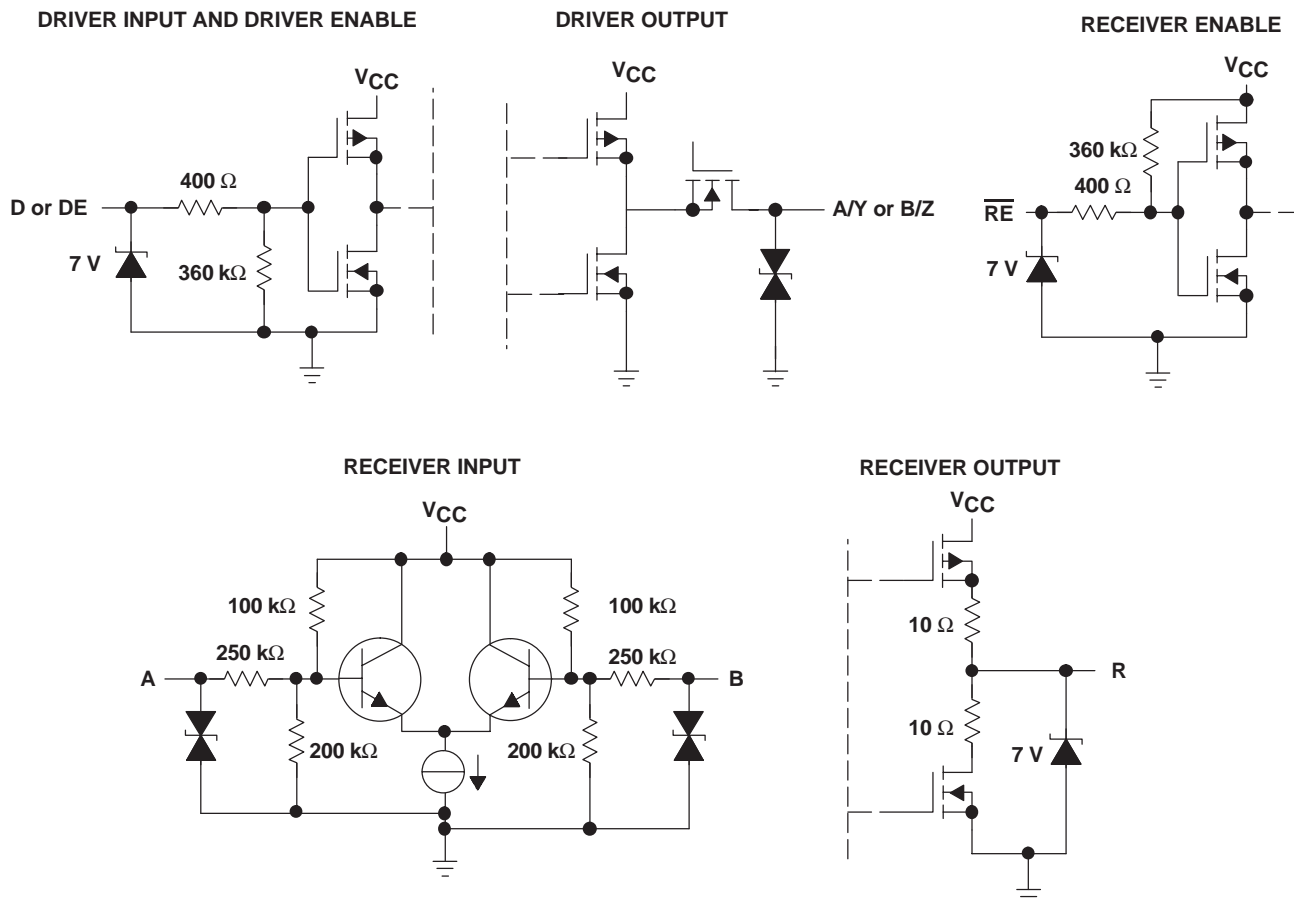

TYPICAL CHARACTERISTICS

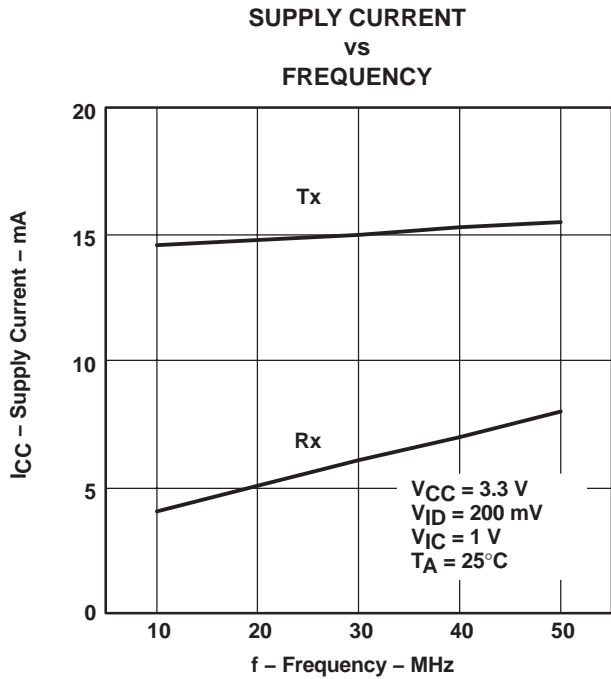

Figure 13

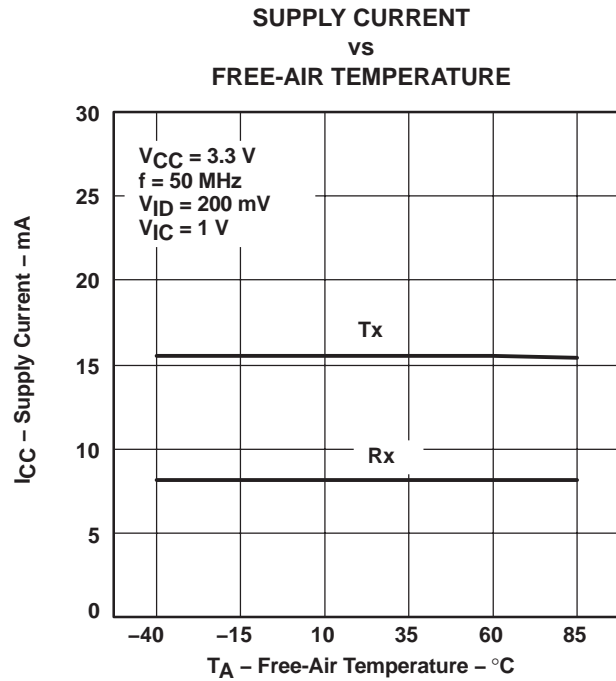

Figure 14

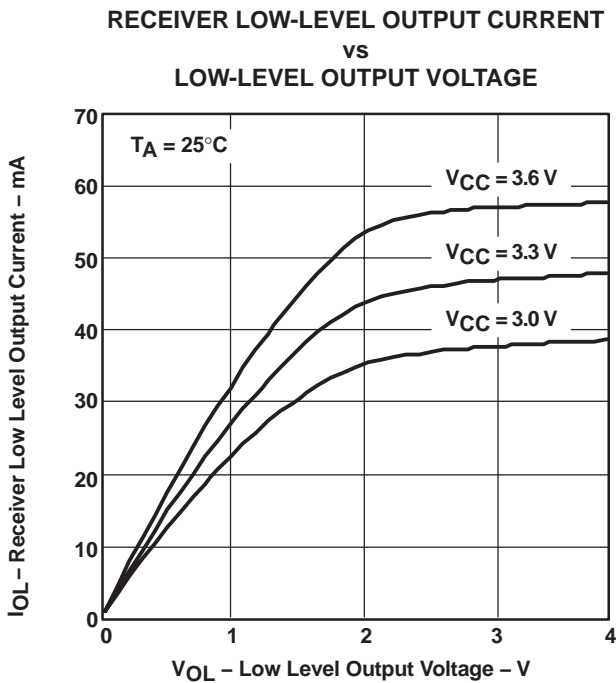

Figure 15

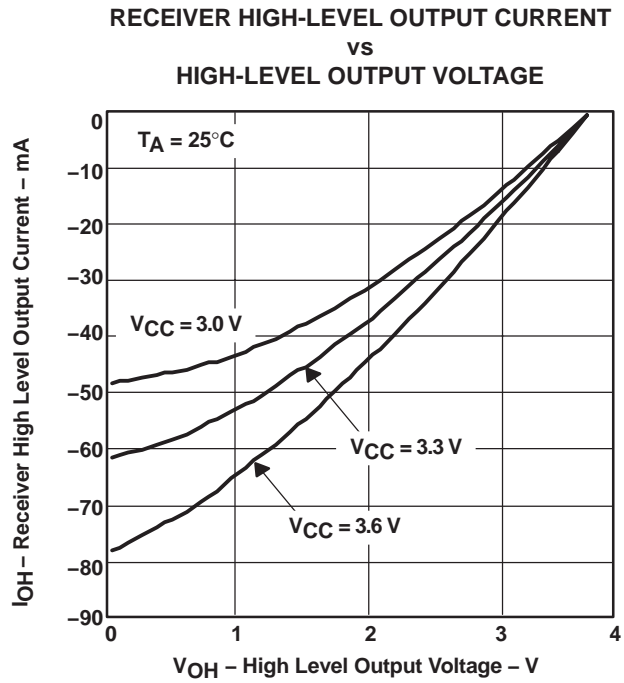

Figure 16

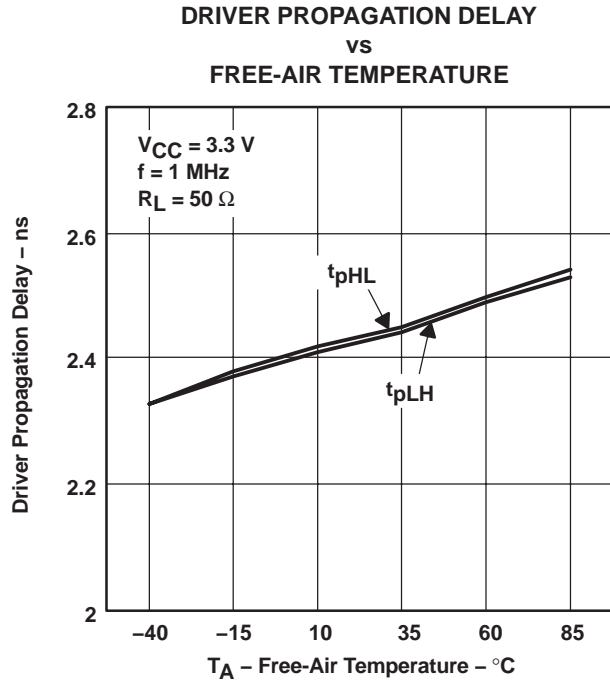

Figure 17

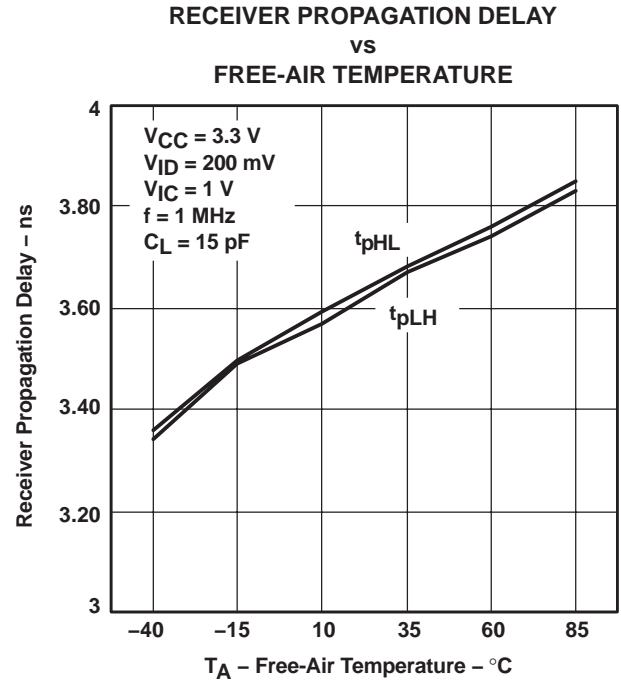

Figure 18

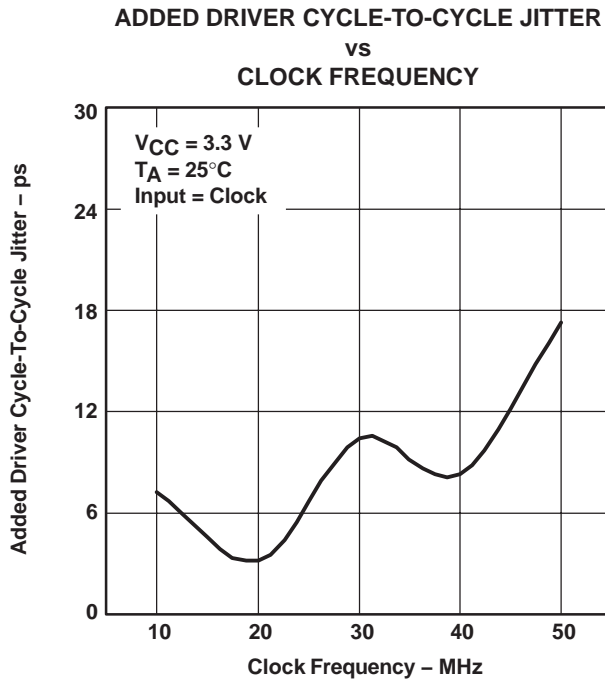

Figure 19

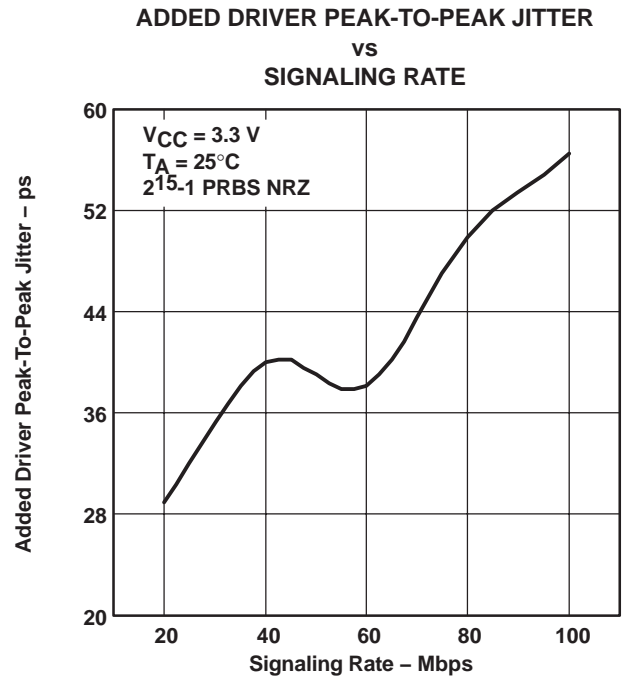

Figure 20

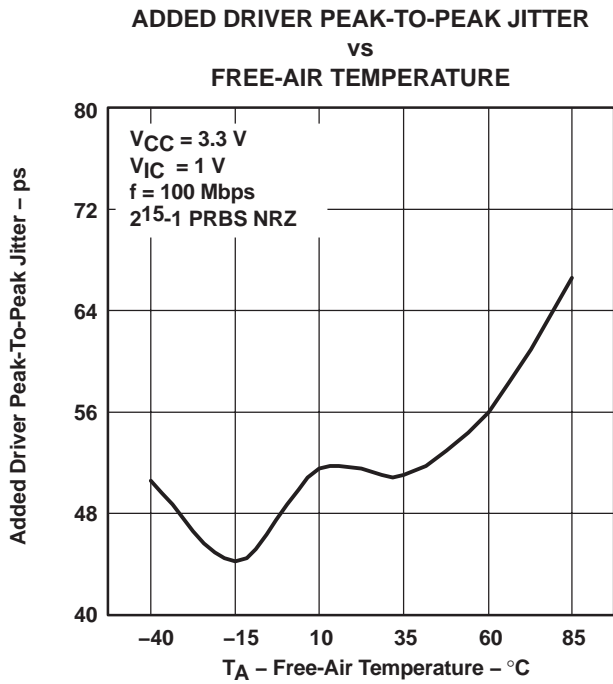

Figure 21

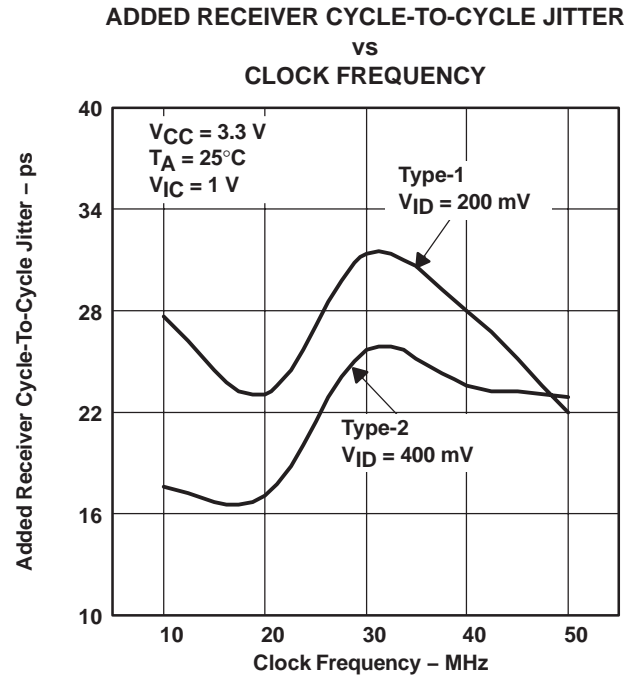

Figure 22

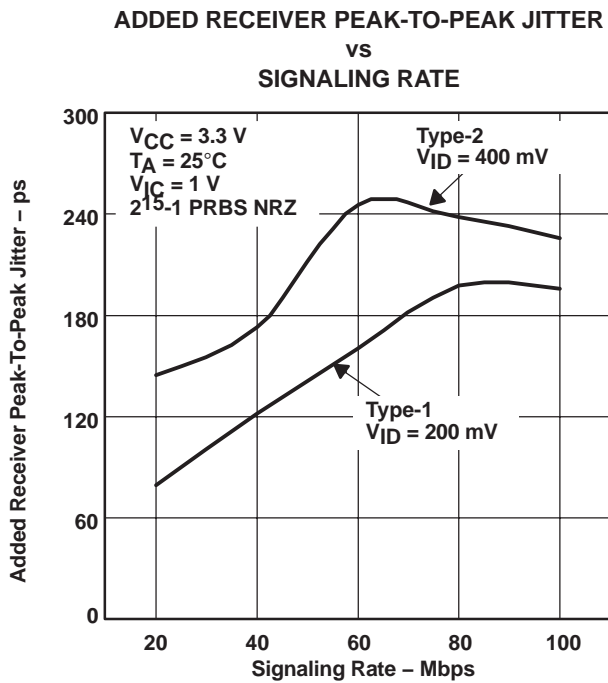

Figure 23

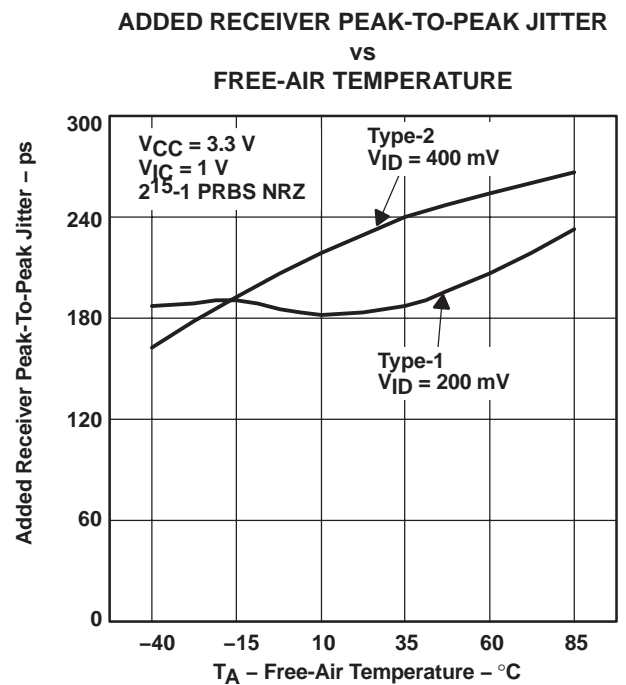
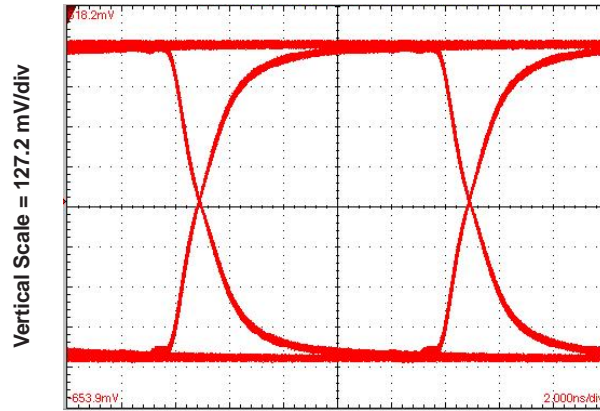

Figure 24

SN65MLVD200A DRIVER OUTPUT EYE  
PATTERN  
100 Mbps,  $2^{15}-1$  PRBS,  $R_L = 50 \Omega$



Horizontal Scale = 2 ns/div

Figure 25

SN65MLVD200A RECEIVER OUTPUT EYE  
PATTERN  
100 Mbps,  $2^{15}-1$  PRBS,  $C_L = 15 \text{ pF}$

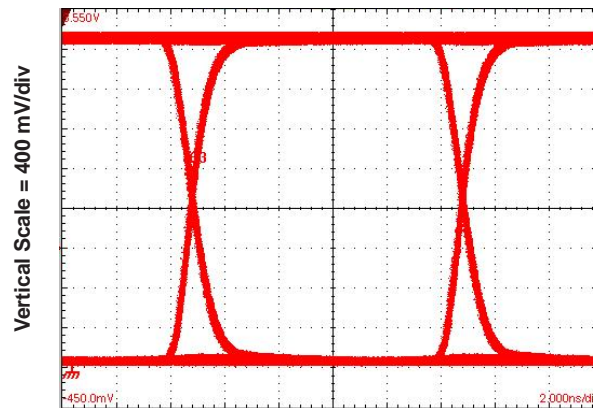

Horizontal Scale = 2 ns/div

Figure 26

APPLICATION INFORMATION

COMPARISON OF MLVD TO TIA/EIA-485

Receiver Input Threshold (Failsafe)

The MLVD standard defines a type 1 and type 2 receiver. Type 1 receivers include no provisions for failsafe and have their differential input voltage thresholds near zero volts. Type 2 receivers have their differential input voltage thresholds offset from zero volts to detect the absence of a voltage difference. The impact to receiver output by the offset input can be seen in Table 3 and Figure 27.

Table 3. Receiver Input Voltage Threshold Requirements

RECEIVER TYPE	OUTPUT LOW	OUTPUT HIGH
Type 1	$-2.4\text{ V} \leq V_{ID} \leq -0.05\text{ V}$	$0.05\text{ V} \leq V_{ID} \leq 2.4\text{ V}$
Type 2	$-2.4\text{ V} \leq V_{ID} \leq 0.05\text{ V}$	$0.15\text{ V} \leq V_{ID} \leq 2.4\text{ V}$

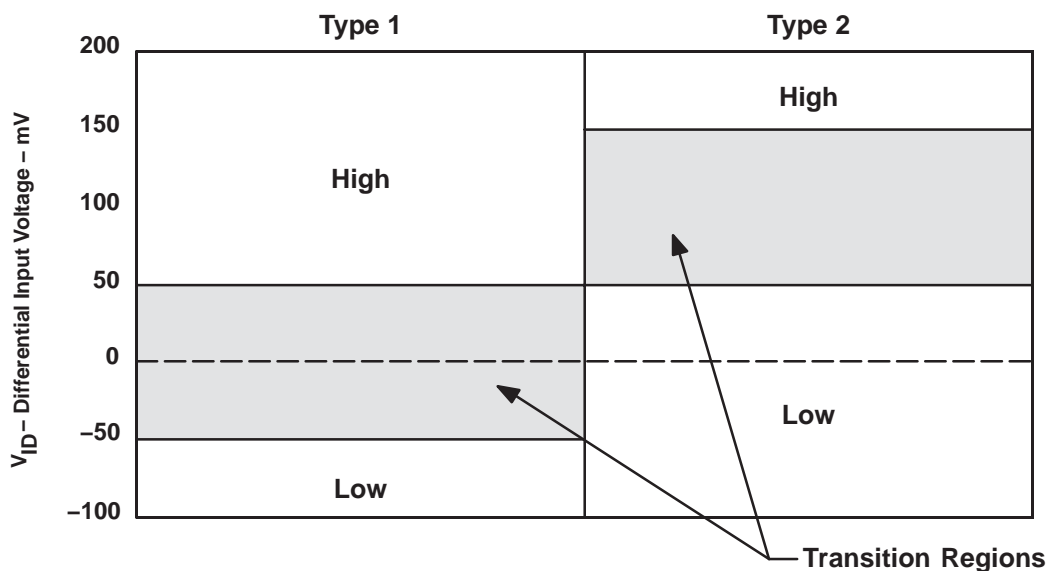

Figure 27. Expanded Graph of Receiver Differential Input Voltage Showing Transition Region

**PACKAGING INFORMATION**

Orderable Device	Status <sup>(1)</sup>	Package Type	Package Drawing	Pins	Package Qty	Eco Plan <sup>(2)</sup>	Lead/Ball Finish	MSL Peak Temp <sup>(3)</sup>
SN65MLVD200AD	ACTIVE	SOIC	D	8	75	Pb-Free (RoHS)	CU NIPDAU	Level-2-260C-1YEAR/ Level-1-220C-UNLIM
SN65MLVD200ADR	ACTIVE	SOIC	D	8	2500	Pb-Free (RoHS)	CU NIPDAU	Level-2-260C-1YEAR/ Level-1-220C-UNLIM
SN65MLVD202AD	ACTIVE	SOIC	D	14	50	Pb-Free (RoHS)	CU NIPDAU	Level-2-260C-1YEAR/ Level-1-220C-UNLIM
SN65MLVD202ADR	ACTIVE	SOIC	D	14	2500	Pb-Free (RoHS)	CU NIPDAU	Level-2-260C-1YEAR/ Level-1-220C-UNLIM
SN65MLVD204AD	ACTIVE	SOIC	D	8	75	Pb-Free (RoHS)	CU NIPDAU	Level-2-260C-1YEAR/ Level-1-220C-UNLIM
SN65MLVD204ADR	ACTIVE	SOIC	D	8	2500	Pb-Free (RoHS)	CU NIPDAU	Level-2-260C-1YEAR/ Level-1-220C-UNLIM
SN65MLVD204ADRG4	PREVIEW	SOIC	D	8	2500	None	Call TI	Call TI
SN65MLVD205AD	ACTIVE	SOIC	D	14	50	Pb-Free (RoHS)	CU NIPDAU	Level-2-260C-1YEAR/ Level-1-220C-UNLIM
SN65MLVD205ADR	ACTIVE	SOIC	D	14	2500	Pb-Free (RoHS)	CU NIPDAU	Level-2-260C-1YEAR/ Level-1-220C-UNLIM

<sup>(1)</sup> The marketing status values are defined as follows:

**ACTIVE:** Product device recommended for new designs.

**LIFEBUY:** TI has announced that the device will be discontinued, and a lifetime-buy period is in effect.

**NRND:** Not recommended for new designs. Device is in production to support existing customers, but TI does not recommend using this part in a new design.

**PREVIEW:** Device has been announced but is not in production. Samples may or may not be available.

**OBSOLETE:** TI has discontinued the production of the device.

<sup>(2)</sup> Eco Plan - May not be currently available - please check <http://www.ti.com/productcontent> for the latest availability information and additional product content details.

**None:** Not yet available Lead (Pb-Free).

**Pb-Free (RoHS):** TI's terms "Lead-Free" or "Pb-Free" mean semiconductor products that are compatible with the current RoHS requirements for all 6 substances, including the requirement that lead not exceed 0.1% by weight in homogeneous materials. Where designed to be soldered at high temperatures, TI Pb-Free products are suitable for use in specified lead-free processes.

**Green (RoHS & no Sb/Br):** TI defines "Green" to mean "Pb-Free" and in addition, uses package materials that do not contain halogens, including bromine (Br) or antimony (Sb) above 0.1% of total product weight.

<sup>(3)</sup> MSL, Peak Temp. -- The Moisture Sensitivity Level rating according to the JEDEC industry standard classifications, and peak solder temperature.

**Important Information and Disclaimer:** The information provided on this page represents TI's knowledge and belief as of the date that it is provided. TI bases its knowledge and belief on information provided by third parties, and makes no representation or warranty as to the accuracy of such information. Efforts are underway to better integrate information from third parties. TI has taken and continues to take reasonable steps to provide representative and accurate information but may not have conducted destructive testing or chemical analysis on incoming materials and chemicals. TI and TI suppliers consider certain information to be proprietary, and thus CAS numbers and other limited information may not be available for release.

In no event shall TI's liability arising out of such information exceed the total purchase price of the TI part(s) at issue in this document sold by TI to Customer on an annual basis.

D (R-PDSO-G14)

PLASTIC SMALL-OUTLINE PACKAGE

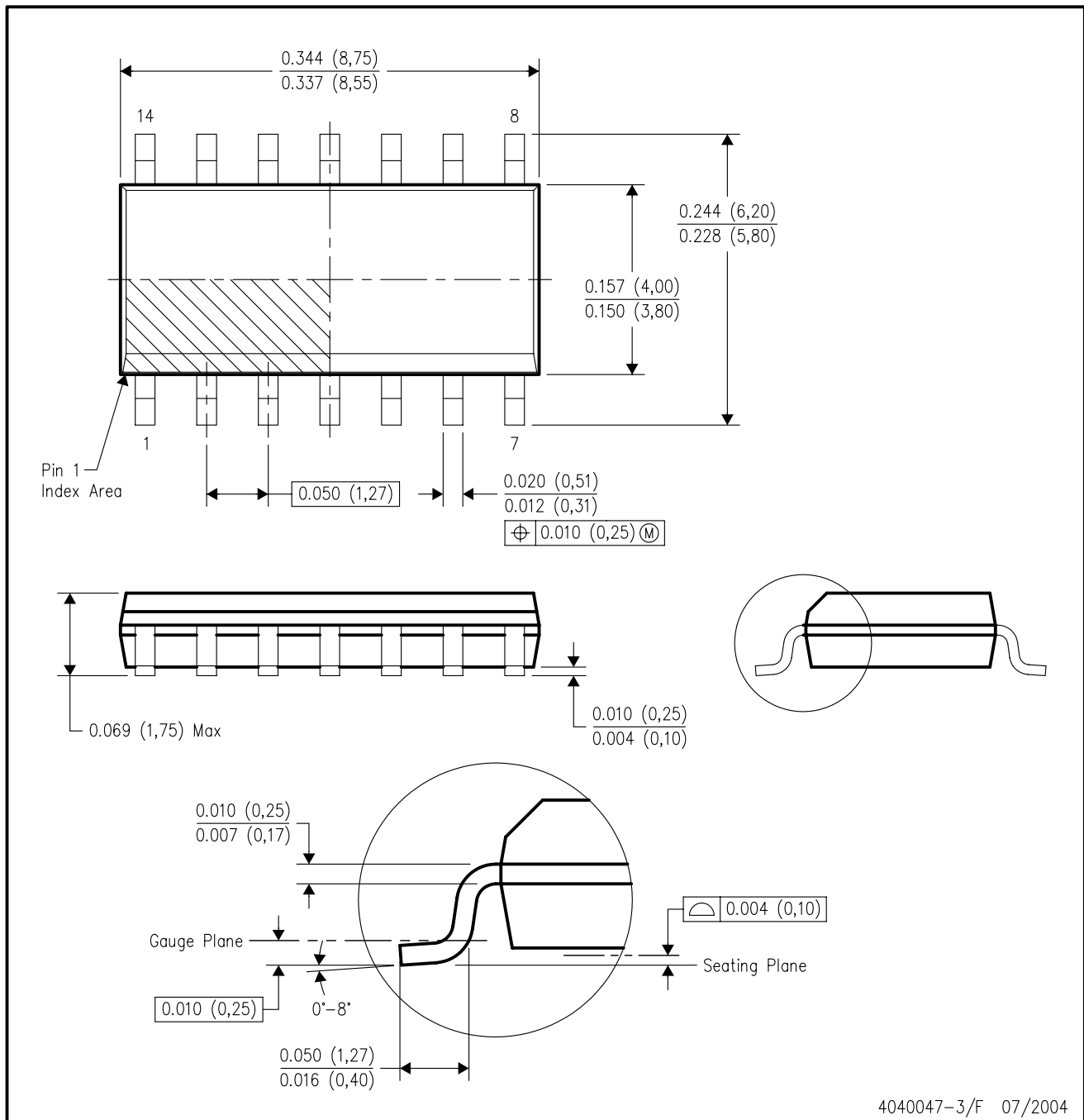

- NOTES:
- A. All linear dimensions are in inches (millimeters).
  - B. This drawing is subject to change without notice.
  - C. Body dimensions do not include mold flash or protrusion not to exceed 0.006 (0,15).
  - D. Falls within JEDEC MS-012 variation AB.



## IMPORTANT NOTICE

Texas Instruments Incorporated and its subsidiaries (TI) reserve the right to make corrections, modifications, enhancements, improvements, and other changes to its products and services at any time and to discontinue any product or service without notice. Customers should obtain the latest relevant information before placing orders and should verify that such information is current and complete. All products are sold subject to TI's terms and conditions of sale supplied at the time of order acknowledgment.

TI warrants performance of its hardware products to the specifications applicable at the time of sale in accordance with TI's standard warranty. Testing and other quality control techniques are used to the extent TI deems necessary to support this warranty. Except where mandated by government requirements, testing of all parameters of each product is not necessarily performed.

TI assumes no liability for applications assistance or customer product design. Customers are responsible for their products and applications using TI components. To minimize the risks associated with customer products and applications, customers should provide adequate design and operating safeguards.

TI does not warrant or represent that any license, either express or implied, is granted under any TI patent right, copyright, mask work right, or other TI intellectual property right relating to any combination, machine, or process in which TI products or services are used. Information published by TI regarding third-party products or services does not constitute a license from TI to use such products or services or a warranty or endorsement thereof. Use of such information may require a license from a third party under the patents or other intellectual property of the third party, or a license from TI under the patents or other intellectual property of TI.

Reproduction of information in TI data books or data sheets is permissible only if reproduction is without alteration and is accompanied by all associated warranties, conditions, limitations, and notices. Reproduction of this information with alteration is an unfair and deceptive business practice. TI is not responsible or liable for such altered documentation.

Resale of TI products or services with statements different from or beyond the parameters stated by TI for that product or service voids all express and any implied warranties for the associated TI product or service and is an unfair and deceptive business practice. TI is not responsible or liable for any such statements.

Following are URLs where you can obtain information on other Texas Instruments products and application solutions:

<b>Products</b>		<b>Applications</b>	
Amplifiers	<a href="http://amplifier.ti.com">amplifier.ti.com</a>	Audio	<a href="http://www.ti.com/audio">www.ti.com/audio</a>
Data Converters	<a href="http://dataconverter.ti.com">dataconverter.ti.com</a>	Automotive	<a href="http://www.ti.com/automotive">www.ti.com/automotive</a>
DSP	<a href="http://dsp.ti.com">dsp.ti.com</a>	Broadband	<a href="http://www.ti.com/broadband">www.ti.com/broadband</a>
Interface	<a href="http://interface.ti.com">interface.ti.com</a>	Digital Control	<a href="http://www.ti.com/digitalcontrol">www.ti.com/digitalcontrol</a>
Logic	<a href="http://logic.ti.com">logic.ti.com</a>	Military	<a href="http://www.ti.com/military">www.ti.com/military</a>
Power Mgmt	<a href="http://power.ti.com">power.ti.com</a>	Optical Networking	<a href="http://www.ti.com/opticalnetwork">www.ti.com/opticalnetwork</a>
Microcontrollers	<a href="http://microcontroller.ti.com">microcontroller.ti.com</a>	Security	<a href="http://www.ti.com/security">www.ti.com/security</a>
		Telephony	<a href="http://www.ti.com/telephony">www.ti.com/telephony</a>
		Video & Imaging	<a href="http://www.ti.com/video">www.ti.com/video</a>
		Wireless	<a href="http://www.ti.com/wireless">www.ti.com/wireless</a>

Mailing Address: Texas Instruments  
Post Office Box 655303 Dallas, Texas 75265